

Features

- Four Channels Of Integrated Laser Diode Drive & Control
- Operates From Single 3.3 Volt Power Supply
- IEEE 802.3ae Compliant, XAUI Compatible Interface
- GBIC Compatible Single Point Failure Detection
- Application Specific Programmability, Including
 - Modulation Current
 - Modulation Current Temperature Coefficient
 - Duty Cycle Control

Quad Programmable 3.125Gb/s Laser Diode Driver

Functional Block Diagram

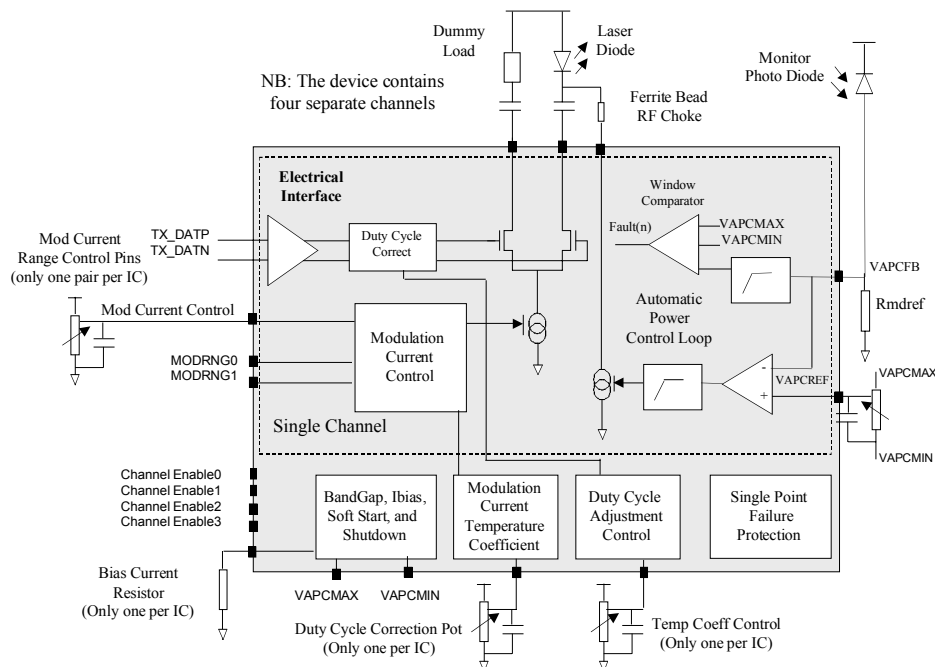

Product Description

The Honeywell HRF-TX1000 is designed for IEEE 802.3 10 Gb/s Ethernet Fiber Optic applications using the XAUI standard interface input. This quad, 3.125 Gb/s, fully integrated laser driver is manufactured using Honeywell's patented Silicon On Insulator (SOI) technology.

The HRF-TX1000 has programmable bias control, modulation control, temperature compensation and closed loop bias control, which enables compatibility with many laser diodes and ensures optical-power stability over environmental conditions and time.

Each channel can be individually controlled. Soft start and hot plug operations can be implemented. The HRF-TX1000 operates from a single positive 3.3 Volt power supply and provides a high-level of electronics integration to minimize the need for external components.

Web Site: www.mysoiservices.com
 Email: mysoiservices@honeywell.com

2001 TX1000 Published May 2001 Page 1

Honeywell
 Solid State Electronics Center
 12001 State Highway 55
 Plymouth, Minnesota 55441-4799
 1-800-323-8295

Product Architecture

The functional block diagram above shows one of four identical channels and the common control logic. The Bandgap, Current Bias Generator, Duty Cycle Control, Temperature Coefficient Control, SPF and soft start blocks are common to all 4 channels, and there is also only one reference current bias resistor and one duty cycle adjust, and temp. coefficient select Pot for all four channels. The laser diode will always be connected common-anode, and the monitor photo diode common-cathode.

Peak to peak amplitude of modulation current is controlled by an external digital Pot (IMOD_POT) and two digital inputs (hardwired) MODRNG0 and MODRNG1 which select the corresponding modulation current range. There are four ranges in total and the IMOD_POT is used to select one of 6 linear steps within the range. The temperature coefficient of the modulation current can be selected from the range 1000ppm to 6000ppm in 1000ppm steps using the IMOD_TC pot.

The DC bias current of the laser diode is controlled by the IDC_POT and the RAPC resistor and the laser diode average optical power being maintained by the APC loop in order to account for temperature variations and aging of the laser diode itself. Note that each of the four separate channels can be tested independently by disabling the other three channels. This can be achieved by setting their digital enable inputs low.

General Specifications

Symbol	Parameter	Conditions	Min	Typ	Max	Units
Temp	Operating Temperature		0	25	140	°C
VDD	Supply Voltage	DC	2.97	3.3	3.63	V
IDD (Tx)	Supply Current (Note 1)	DC	280	300	340	mA
Ptotal	Total Power Dissipation (2)	DC			2.0	W

Note 1: The supply current specified through the VDD pins.

Note 2: The total power dissipation includes the IC supply current IDD and the laser DC bias current.

Laser Modulation Specifications

Symbol	Parameter	Conditions	Min	Typ	Max	Units
TX_BPS	Bit-Rate		2.45	3.125	3.20	Gbit/s
TX_EDGE	Rise / Fall Time, 20-80%				100	ps
TX_DJ	Jitter (Deterministic) (Pk/Pk) (Note 3,4)				20	ps
TX_RJ	Jitter (Random)(Pk/Pk) For A BER Of 10^{-12} (Note 4)				38	ps
TX_TJ	Jitter (Total) (Pk/Pk) For A BER Of 10^{-12} (Note 4)				58	ps
IMOD1_ABS_MIN	Absolute Minimum Laser Modulation Current (Logic 1)				2	mA
IMOD1_ABS_MAX	Absolute Maximum Laser Modulation Current (Logic 1)		35			mA
IMOD0	Modulation Current (Logic 0)			0		mA
IMOD1_R1	Modulation Logic 1 Current Range 1 (Note 5)		2		6	mA
IMOD1_R2	Modulation Logic 1 Current Range 2 (Note 5)		4		12	mA
IMOD1_R3	Modulation Logic 1 Current Range 3 (Note 5)		8		24	mA
IMOD1_R4	Modulation Logic 1 Current Range 3 (Note 5)		16		35	mA
IMOD_OS	Modulation Current Maximum Overshoot			20		%
VMOD_CTRL	Control Voltage Used To Set The Modulation Current Step In The Appropriate Range. (Note 6)	DC	VAPC MIN		VAPCM AX	V
TCMOD	Modulation Reference Voltage Temperature Coefficient (Note 7)		1000		6000	+ppm/ $^{\circ}$ C
EXR	Extinction Ratio		7			dB
FTX	Low Frequency Cutoff (Electrical -3db) (Note 8)				3	MHz
DUTYADJ	Pulse Width Adjustment Range (Note 8)			+/-40		ps
DUTYTOL	Pulse Width Adjustment Range Tolerance					%
RPOT	Pot Resistance (Per Pot)	DC		10		kOhms

Note 3: Peak-To-Peak Deterministic Jitter Tested With Repeated K28.5 Character /1100000101/0011111010/ At 3.125 Gbit/S

Note 4: Jitter Is Specified For The Transmitter Only And Does Not Include That Generated By The Laser Itself.

Note Random Jitter Has A Gaussian Distribution, And So The Contributions Of The Laser Diode And Driver Random Jitter Are Added Rms.

Note 5: The Modulation Current Step Size Increases With Increasing Range, However The Resulting Optical Laser Diode Output Power Step Size Will Be Linear.

Note 6: The Modulation Current (Peak-To-Peak) Is Determined By The Modulation Reference Voltage And The Modulation Current Range.

A Minimum VMOD_CTRL Will Produce The Minimum IMOD Current For The Selected Range And Conversely A Maximum VMOD_CTRL Will Produce The Maximum IMOD Current For That Range. Each Range Having A Total Number Of 6 Steps Per Range With A Linear Step Size. A Separate IMOD_POT Potentiometer Is Used To Program Each Channel, With Each POT Pre-Programmed On A Per-Part And Per-Channel Basis In Order To Achieve The Required Extinction Ratio Despite Part-To-Part Variations In Laser Slope Efficiency. The Laser Diode Driver IC Plays No Part In The Programming Of This Resistor.

Note 7: The Temperature Coefficient Is With Respect To Silicon Junction Temperature Which May Be Different From Laser Diode Junction Temperature. The Ratio-Metric Temperature Coefficient Of The POT Controlling The Modulation Current Has Been Specified As 20ppm By The Pot Selection

Note 8: 8B/10B Coding Is Used For All Data Channels

Web Site: www.mysoiservices.com
 Email: mysoiservices@honeywell.com

2001 TX1000 Published May 2001 Page 3

Honeywell
 Solid State Electronics Center
 12001 State Highway 55
 Plymouth, Minnesota 55441-4799
 1-800-323-8295

Typical Modulation Current Values

Modulation Current Range	IMODRNG0 Setting	IMODRNG1 Setting	Minimum	Maximum	Units
1	0	0	2	6	mA
2	0	1	4	12	mA
3	1	0	8	24	mA
4	1	1	12	36	mA

Automatic Power Control Specifications

Symbol	Parameter	Conditions	Min	Typ	Max	Units
VDDAPC	Supply Voltage Over Which APC Block Is Functional		2.80		3.63	V
VAPCREf	Reference Voltage Range For Automatic Power Control (Note 9)		VAPCMIN		VAPCMAX	V
VAPCMAX	Shutdown Threshold. Corresponds To 2 X IAPCMIN (Upper Limit)			1.2		V
VAPCMIN	Power-On Threshold. Corresponds To IAPCMIN (Lower, Power Rising)			0.6		V
IMON_RNG	Monitor Diode Absolute Current Range		10	75	450	μA
RAPC	Reference Resistor Range, Defined By IMON_RNG And VAPCREf (Note 10)		3.3		90.0	Kohms
VAPCHYS	Hysteresis In VAPCMIN			100		mV
TCBIAS	Temperature Coefficient Of Bias Reference Voltage			20		ppm
IBIASMIN	Minimum Bias Current Generated By Feedback Loop				1	mA
IBIASMAX	Maximum Bias Current Generated By Feedback Loop		75			mA
CAPC	Total Capacitance At Monitor Pin (Note 11)		0.3	0.75	0.9	pF
IBOV	Overshoot In Bias Current At Turn On (Note12)				24	%

Note 9: The VAPCMAX And VAPCMIN Outputs Enable Maximum Dynamic Range Of The Digital POT Output For VAPCREf.

Note 10: The Resistor Value Is Selected By The User For The Appropriate Laser/Monitor Diode Arrangement.

Note 11: This Capacitance Is Due To The Pcb Parasitics And Is Required In Order To Ensure The Stability Of The APC Feed Back Loop.

Note 12: At Extreme Corners, Such That IMOD=2ma And IBIAS>55ma This Maximum Spec May Be Exceeded. This Is Not A Realistic Problem

Since For Modulation Currents Of 2ma The IBIAS Lasing Threshold Current Will Be Less Than 55mA.

The bias current is adjusted under feedback control such that the time-averaged photo-current through the monitor photodiode is held constant. The steady-state value of this current is determined by the reference voltage VAPCREf and the value of the external resistor RAPC. (IMON = VAPCREf / RAPC) Separate resistors and IDC_POTs are used for each channel. The RAPC resistor value is selected to suit the laser/monitor diode arrangement used and the value of the VAPCREf inputs are programmed on a per-part and per-channel basis using an external digital potentiometer. The HRF-TX1000 plays no part in the programming of this reference level. It is assumed that VAPCMAX and VAPCMIN refer to the time averaged maximum and minimum levels possible, and not the transient levels which may exceed this range.

Laser Diode And Monitor Photodiode Specifications

Symbol	Parameter	Conditions	Min	Typ	Max	Units
ITH	Lasing Threshold Current		3	12	50	mA
VTH	Lasing Threshold Voltage		0.9	1.1	1.6	V
VTHT	($\Delta I_{th}/\Delta T$) Threshold Current Temperature Dependence Coefficient		0		2.5	mA/°C
ETALD	Laser Diode Slope Efficiency (Note 13)		0.005	0.035	0.075	W / A
ETALDT	($\Delta \eta/\Delta T$) Slope Efficiency Temperature Dependence Coefficient.		1000		6000	-ppm/°C
CLD	Laser Diode Capacitance (Note 14)		0.1	1.4	1.8	pF
CMON	Monitor Photo-Diode Capacitance		3	7	20	pF
RMON	Monitor Photodiode Responsivity		0.5	0.8	1.0	A / W
α .RMON	Monitor Photodiode Responsivity (Note 15)		0.015	0.045	0.15	A / W

Note 13: These Parameters Are Required For Simulating The Transient Behaviour Of The Automatic Power Control Feedback Loop. The Requirement For The IC To Meet The Specifications In The Previous Section Are That The Characteristics Of The Laser Diode Are Within The Specified Ranges.

Note 14: The Cap Range Is To Encompass A Variety Of Different Manufacturers Laser Diodes. Large Signal Model Optimized Against Small Signal Model At $I_{th}+5ma$. In AXT OIC Device A Higher I_{th} Results In A Lower CLD Of 0.1pf. In Sumitomo And Mitsubishi Laser Diodes CLD Of 1.4pf

Note 15: Includes Approx. 5db Of Coupling Losses And 20% Laser Diode Back Facet Power. The Correlation Of α .RMON And ETALD Is Such That The Worst Cases Cannot Occur Simultaneously And Still Meet The IMON_RNG Minimum Value.

Control Interface Timing Specifications

Symbol	Parameter	Conditions	Min	Typ	Max	Units
T_OFF	TX_DISABLE Assert Delay				10	uS
T_ON	TX_DISABLE Negate Delay				1	mS
T_FAULT	TX_FAULT Assert Delay				100	uS
T_RESET	Min TX_DISABLE Pulse Width To Reset Fault		10			us
VPON	Power On Detect Threshold (Notes 16, 17)	(TBR)		90% of $V_{cc\ nom}$ (3.3V)		V
T_INIT	Delay Between Power On Detect And TX_FAULT Clear				300	mS
TLO_INH	Inhibit Of Low Laser Power Fault Condition After Power On	(TBR)			300	mS

Note 16: The laser driver circuits are not enabled until VDD exceeds the power on threshold VPON. Assumes a bandgap tolerance of $\pm 5\%$. After the initial power-on detect, the circuit latches into a power-up state and does not detect subsequent under voltage conditions.

Note 17: In practice may be slightly lower to ensure a power on detect at minimum supply voltage. During normal operation, a fault condition occurs when, on one or more channels, OVERPWR: the voltage on the pin VAPCFB<0:3> exceeds VAPCMAX or LOPWR: the voltage on the pin VAPCFB<0:3> is below VAPCMIN. During the power-on transient state, the LOPWR fault condition is inhibited for a time TLO_INH. OVERPWR faults are still detected in this state. In the fault state, the laser drivers are shutdown. From this state, if DISABLE is held high for T_RESET then the circuit goes to the power-on transient state.

Web Site: www.mysoiservices.com
 Email: mysoiservices@honeywell.com

2001 TX1000 Published May 2001 Page 5

Honeywell
 Solid State Electronics Center
 12001 State Highway 55
 Plymouth, Minnesota 55441-4799
 1-800-323-8295

Flow Diagram (TX_FAULT, Laser Enable)

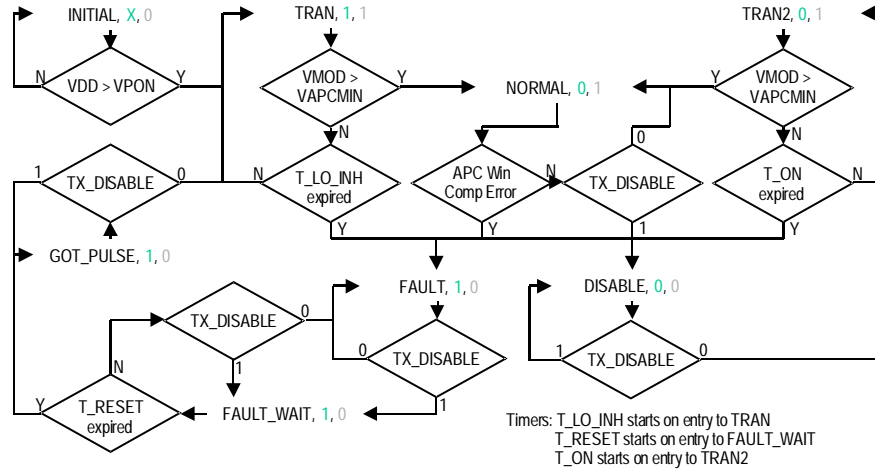

State Diagram Illustrating Operation Of HRF-TX1000
 Control Interface And Shutdown Circuitry

Connection List

Type : P =Power/Gnd, I =Input, O =Output,

A logic 1 on TX_DAT corresponds to a bright laser diode.

A logic 0 on TX_DAT corresponds to a dark laser diode.

Pin Name	Type	Description
TX_DATP<0:3>	I	Non-Inverting Input, Channels 0-3
TX_DATN<0:3>	I	Inverting Input, Channels 0-3
VAPCFB<0:3>	I	Monitor Photodiode Anode/RAPC Connection.
VAPCREF<0:3>	I	APC Reference Input Level.
TX_FAULT	O	Control Interface – Fault Indicator
TX_DISABLE	I	Control Interface – Disable Input
TX_BIAS<0:3>	O	DC Bias Current Output To Laser
TX_MOD<0:3>	O	High Speed Modulation Current To Laser
TX_DUMMY<0:3>	O	High Speed Modulation Current Dummy Output
VMOD_CTRL<0:3>	O	Modulation Reference Voltage, Channels 0-3
VTC_CTRL	I	Modulation Temperature Coefficient Control.
MODRNG0	I	Modulation Current Range Input Lsb.
MODRNG1	I	Modulation Current Range Input Msb.
RDUTY	I	Duty Cycle Correction Pin
GND_LD<0:3>	P	Laser Drivers
GND_TX<0:3>	P	Electrical Interface Grounds
GND_BG	P	Bandgap And Ibias Ground
GND_APC (x2)	P	Apc Ground
GND_MOD (x2)	P	Mod Current Ctrl Ground
VCC_TX<0:4>	P	Electrical Interface Vcc
VCC_BG	P	Bandgap And Ibias Ground
VCC_APC (x2)	P	Apc Supply
VCC_MOD (x2)	P	Mod Current Ctrl Supply
VCC_DRIVE (x4)	P	Laser Drive Circuit Vcc
RBIAS	O	Bias Current Resistor
VAPCMAX	O	APC Loop Max Reference Voltage
VAPCMIN	O	APC Loop Min Reference Voltage
PONDELAY	O	Connection To External Capacitor For The SPF 300ms Delay.
SPFDELAY	O	Connection To External Capacitor For The SPF 1ms Delay.
CHANNEL_ENABLE (x4)	I	Channel Enable (1) /Disable (0) Logic Inputs.

External Components

Name	Component	Description
Lbiaschoke<0:3>	Ferrite Bead	Part Of Network For Laser Diode
Lmodcouple<0:3>	Capacitor	Part Of Network For Laser Diode
Dummyload<0:3>	Resistor	Part Of Network For Dummy Load
Dmodcouple<0:3>	Capacitor	Part Of Network For Dummy Load
Lddecouple	Capacitor	Laser Diode Vcc Decoupling
Cdelay1	Capacitor	Required For 300ms Delay
Cdelay2	Capacitor	Required For 1ms Delay
Duty_Pot	Potentiometer	Required For Duty Cycle Adjustment
Idc_Pot<0:3>	Potentiometer	Digital Potentiometer For Monitor Current Control
Rapc<0:3>	Resistor	Resistor For Imon Current To Apc Feedback
Imod_Pot<0:3>	Potentiometer	Digital Potentiometer For Modulation Current Control (10kΩ Resistance Per Pot)
Cdec<0-4>	TBD	Power Supply De-Coupling
Rbias	22kΩ (+/-1%)	External Bias Current Resistor

The POT's have been specified with a temp coefficient of 300ppm/°C and a ratio-metric temp coefficient of 20ppm/°C.

Typical Application Circuit

Call Honeywell for details

Evaluation Circuit Board

Call Honeywell for details

Ordering Information

Ordering Number	Product
HRF-TX1000-B	Delivered In Die Form(18)
HRF-TX1000-T	Delivered In Flip Chip Form(18)
HRF-TX1000-E	Engineering Evaluation Board

Note 18: Call Honeywell for details

Honeywell reserves the right to make changes to improve reliability, function or design. Honeywell does not assume any liability arising out of the application or use of any product or circuit described herein; neither does it convey any license under its patent rights nor the rights of others.

SUNSTAR 商斯达实业集团是集研发、生产、工程、销售、代理经销、技术咨询、信息服务等为一体的高科技企业，是专业高科技电子产品生产厂家，是具有 10 多年历史的专业电子元器件供应商，是中国最早和最大的仓储式连锁规模经营大型综合电子零部件代理分销商之一，是一家专业代理和分销世界各大品牌 IC 芯片和电子元器件的连锁经营综合性国际公司，专业经营进口、国产名厂名牌电子元件，型号、种类齐全。在香港、北京、深圳、上海、西安、成都等全国主要电子市场设有直属分公司和产品展示展销窗口门市部专卖店及代理分销商，已在全国范围内建成强大统一的供货和代理分销网络。我们专业代理经销、开发生产电子元器件、集成电路、传感器、微波光电元器件、工控机/DOC/DOM 电子盘、专用电路、单片机开发、MCU/DSP/ARM/FPGA 软件硬件、二极管、三极管、模块等，是您可靠的一站式现货配套供应商、方案提供商、部件功能模块开发配套商。商斯达实业公司拥有庞大的资料库，有数位毕业于著名高校——有中国电子工业摇篮之称的西安电子科技大学（西军电）并长期从事国防尖端科技研究的高级工程师为您精挑细选、量身订做各种高科技电子元器件，并解决各种技术问题。

微波光电部专业代理经销高频、微波、光纤、光电元器件、组件、部件、模块、整机；电磁兼容元器件、材料、设备；微波 CAD、EDA 软件、开发测试仿真工具；微波、光纤仪器仪表。欢迎国外高科技微波、光纤厂商将优秀产品介绍到中国、共同开拓市场。长期大量现货专业批发高频、微波、卫星、光纤、电视、CATV 器件：晶振、VCO、连接器、PIN 开关、变容二极管、开关二极管、低噪晶体管、功率电阻及电容、放大器、功率管、MMIC、混频器、耦合器、功分器、振荡器、合成器、衰减器、滤波器、隔离器、环行器、移相器、调制解调器；光电子元件和组件：红外发射管、红外接收管、光电开关、光敏管、发光二极管和发光二极管组件、半导体激光二极管和激光器组件、光电探测器和光接收组件、光发射接收模块、光纤激光器和光放大器、光调制器、光开关、DWDM 用光发射和接收器件、用户接入系统光收发器件与模块、光纤连接器、光纤跳线/尾纤、光衰减器、光纤适配器、光隔离器、光耦合器、光环行器、光复用器/转换器；无线收发芯片和模组、蓝牙芯片和模组。

更多产品请看本公司产品专用销售网站：

商斯达中国传感器科技信息网：<http://www.sensor-ic.com/>

商斯达工控安防网：<http://www.pc-ps.net/>

商斯达电子元器件网：<http://www.sunstare.com/>

商斯达微波光电产品网：[HTTP://www.rfoe.net/](http://www.rfoe.net/)

商斯达消费电子产品网：<http://www.icasic.com/>

商斯达实业科技产品网：<http://www.sunstars.cn/> 微波元器件销售热线：

地址：深圳市福田区福华路福庆街鸿图大厦 1602 室

电话：0755-82884100 83397033 83396822 83398585

传真：0755-83376182 (0) 13823648918 MSN: SUNS8888@hotmail.com

邮编：518033 E-mail:szss20@163.com QQ: 195847376

深圳赛格展销部：深圳华强北路赛格电子市场 2583 号 电话：0755-83665529 25059422

技术支持：0755-83394033 13501568376

欢迎索取免费详细资料、设计指南和光盘；产品凡多，未能尽录，欢迎来电查询。

北京分公司：北京海淀区知春路 132 号中发电子大厦 3097 号

TEL: 010-81159046 82615020 13501189838 FAX: 010-62543996

上海分公司：上海市北京东路 668 号上海赛格电子市场 D125 号

TEL: 021-28311762 56703037 13701955389 FAX: 021-56703037

西安分公司：西安高新开发区 20 所(中国电子科技集团导航技术研究所)

西安劳动南路 88 号电子商城二楼 D23 号

TEL: 029-81022619 13072977981 FAX:029-88789382