

## SP4T Absorptive RF Switch

### Features

- High Isolation Of > 40 dB @ 2 GHz
- Low Insertion Loss Of 1.2dB @ 2 GHz
- DC To 4 GHz Operating Frequency
- Integrated CMOS Control Logic
- Integrated ESD Protection on Digital I/O
- Single Positive Supply Voltage
- Ultra Small LPCC™ Packaging
- Impedance matched for 50 Ohm systems

### Product Description

The Honeywell HRF-SW1020 is a high performance single pole four throw (SP4T) absorptive RF switch that is ideal for use in wireless basestation and handset applications that require minimum power and minimum insertion loss.

The HRF-SW1020 is manufactured with Honeywell's patented Silicon On Insulator (SOI) CMOS technology, which provides the performance of GaAs with the economy and integration capabilities of conventional CMOS technology.

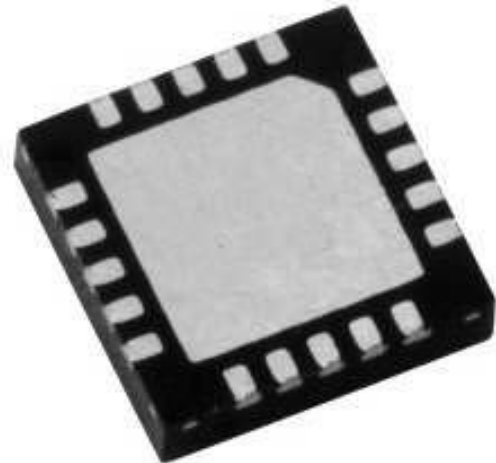

HRF-SW1020 in LPCC™ Package

### RF Electrical Specifications @ + 25°C

Results @ Vdd=5.0 +/- 10%, Vss = 0 unless otherwise stated, Z0= 50 ohms

Parameter	Test Condition	Frequency	Minimum	Typical	Maximum	Units
Insertion Loss		DC - 1.0 GHz		1.15		dB
		2.0 GHz		1.20		dB
		3.0 GHz		1.25		dB
Isolation		DC - 1.0 GHz		62		dB
		2.0 GHz		49		dB
		3.0 GHz		39		dB
VSWR*		DC - 0.5 GHz		1.1:1		Ratio
		0.5 - 2.0 GHz		1.2:1		Ratio
		2.0 - 3.0 GHz		1.3:1	1.4:1	Ratio
1dB Compression	Input Power Vss = Gnd Vss = -3	1.0 GHz		19		dBm
		1.0 GHz		28		dBm
Input IP3	Two-Tone Inputs Up To + 5 dBm Vss = Gnd Vss = -3	2.0 GHz		31		dBm
		2.0 GHz		32		dBm
Trise, Tfall*	10% To 90%			10		nS
Ton, Toff	50% Cntl To 90%/10%Rf			20		nS
Transients	In-Band			10		mV

\*By design

## DC Electrical Specifications @ + 25°C

Parameter	Minimum	Typical	Maximum	Units
Single V <sub>DD</sub> Supply Voltage	3.3*	5.0	5.5	V
CMOS Logic Level (0)	0		0.8	V
CMOS Logic Level (1)	V <sub>DD</sub> - 0.8		V <sub>DD</sub>	V
Input Leakage Current			10	uA

\* Note, performance curves are for V<sub>dd</sub> = +5.0 +/- 10%

## Absolute Maximum Ratings<sup>1</sup>

Parameter	Absolute Maximum	Units
V <sub>DD</sub>	+6.0	V
V <sub>in</sub> Digital Logic 0	V <sub>ss</sub> - 0.6	V
V <sub>in</sub> Digital Logic 1	V <sub>dd</sub> + 0.6	V
Maximum Input Power	> 35	dBm
ESD Voltage	400	V
Operating Temperature Range	+85	Degrees C
Storage Temperature Range	+125	Degrees C

(Note 1) Operation beyond any of these parameters may cause permanent damage.

**Latch-Up:** Unlike conventional CMOS RF switches, Honeywell's HRF-SW1020 is immune to latch-up.

**ESD Protection:** Although this device contains ESD protection circuitry on all digital inputs, conventional precautions should be taken to ensure that the Absolute Maximum Ratings are not exceeded.

## Package Outline Drawing

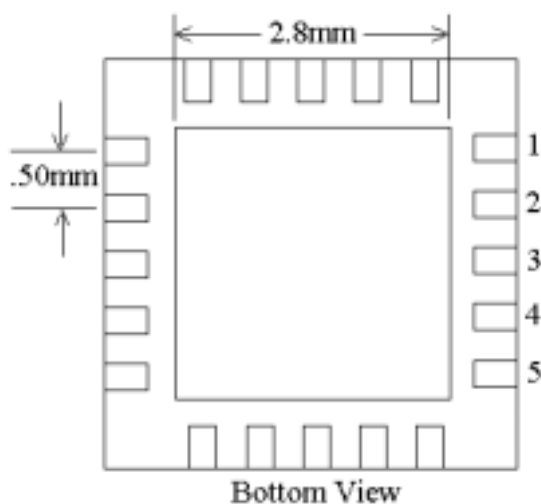

Bottom View, 20 Pin 4X4 mm LPCC™ Package  
 ASAT LPCC Marketing Outline Dwg. # GMJ00004  
 For more information see <http://www.asat.com>

## Truth Table

C1	C0	RF Output 1	RF Output 2	RF Output 3	RF Output 4
0	0	RFINPUT			
0	1		RFINPUT		
1	0			RFINPUT	
1	1				RFINPUT

"0" = CMOS Low, "1" = CMOS High

## Pin Configuration

Pin	Function	Pin	Function
1	GROUND	11	C1
2	RFOUTPUT4	12	C0
3	GROUND	13	GROUND
4	VDD	14	RFOUTPUT1
5	DIGITAL GROUND	15	GROUND
6	RFOUTPUT3	16	GROUND
7	GROUND	17	GROUND
8	GROUND	18	RFINPUT
9	GROUND	19	GROUND
10	RFOUTPUT2	20	VSS

## Evaluation Circuit Board Connections

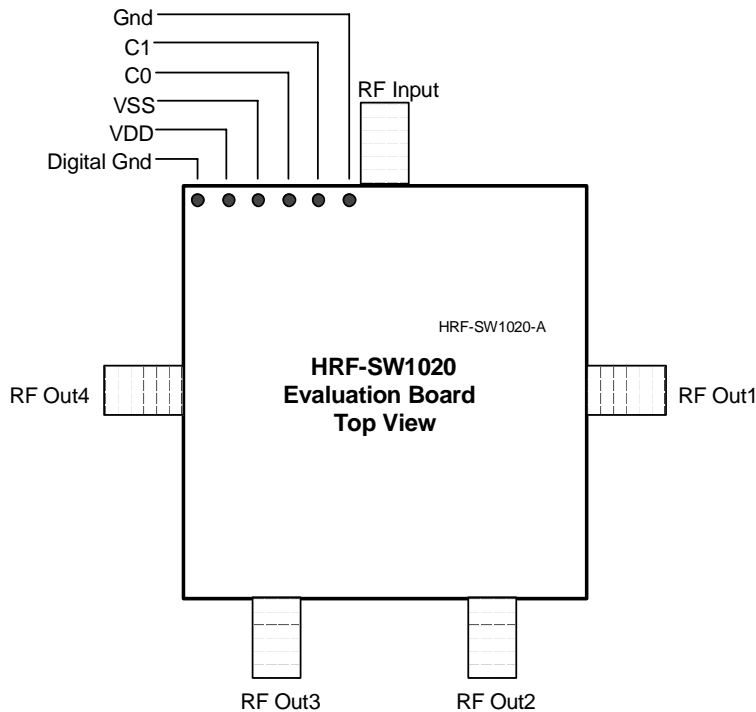

"0" = CMOS Low, "1" = CMOS

## Performance Curves

### Insertion Loss

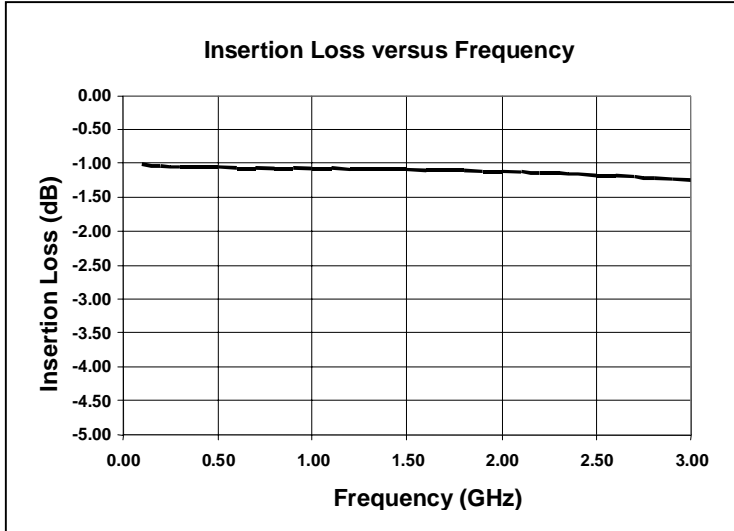

The Insertion Loss curve shows the worst case loss versus frequency at  $V_{dd} = +5.0$   $\pm 10\%$ ,  $T_a = 25^\circ\text{C}$ ,  $Z_0 = 50$  Ohms.

### Isolation

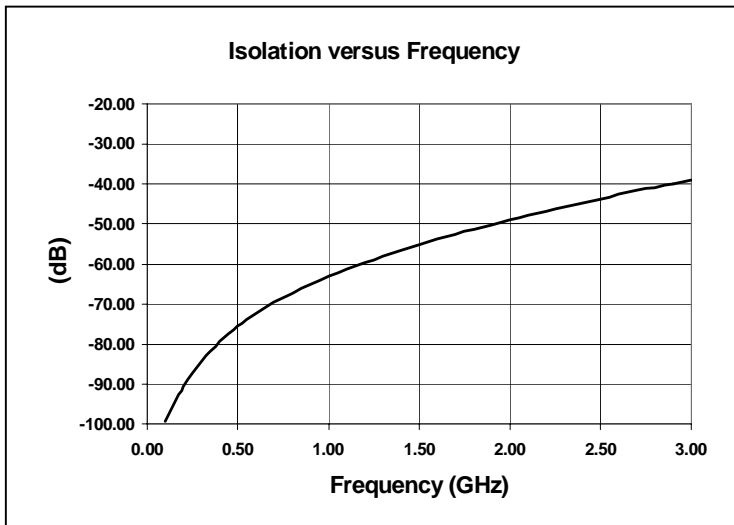

The Isolation curve shows the typical isolation of an "off" state output to the insertion path.

## Return Loss

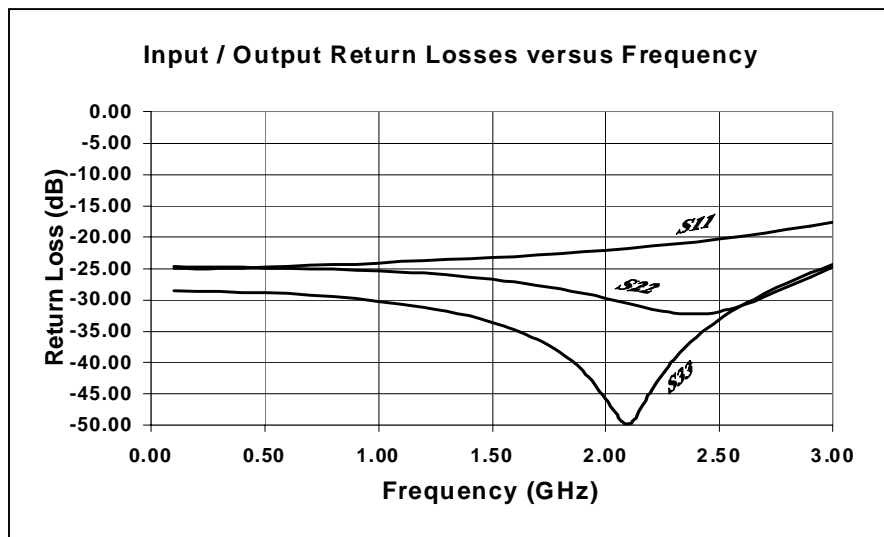

The return loss curve shows the input return loss S11, the output return loss in the insertion path S22, and the output return loss in the isolation state S33.

## Evaluation Circuit Board

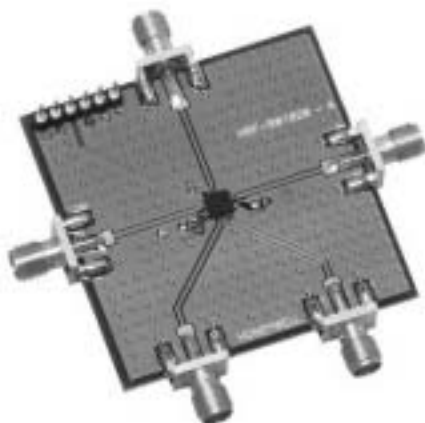

HRF-SW1020 Evaluation Board

Honeywell's evaluation board provides an easy to use method of evaluating the RF performance of our switch. Simply connect power, DC and RF signals to be measuring switch performance in less than 10 minutes.

## Evaluation Circuit Board Layout Design Details

Item	Description
PCB	Impedance Matched Multi-Layer FR4
Switch	HRF-SW1020 RF Switch
Chip Capacitor	Panasonic Model ECU-E1C103KBQ Capacitor, .01uf 0402 10% 16V
RF Connector	Johnson Connectors Model 142-0701-801 SMA RF Coaxial Connector
DC Pin	Mil-Max Model 800-10-064-10-001 Header Pins

## Ordering Information

Ordering Number	Product
HRF-SW1020-B	Delivered In Chip Tubes
HRF-SW1020-TR	Delivered On Tape And Reel <sup>2</sup>
HRF-SW1020-E	Engineering Evaluation Board

(Note 2) Contact Honeywell for details

LPCC™ is a registered Trademark of ASAT Ltd.

Honeywell reserves the right to make changes to improve reliability, function or design. Honeywell does not assume any liability arising out of the application or use of any product or circuit described herein; neither does it convey any license under its patent rights nor the rights of others.

SUNSTAR 商斯达实业集团是集研发、生产、工程、销售、代理经销、技术咨询、信息服务等为一体的高科技企业，是专业高科技电子产品生产厂家，是具有 10 多年历史的专业电子元器件供应商，是中国最早和最大的仓储式连锁规模经营大型综合电子零部件代理分销商之一，是一家专业代理和分销世界各大品牌 IC 芯片和电子元器件的连锁经营综合性国际公司，专业经营进口、国产名厂名牌电子元件，型号、种类齐全。在香港、北京、深圳、上海、西安、成都等全国主要电子市场设有直属分公司和产品展示展销窗口门市部专卖店及代理分销商，已在全国范围内建成强大统一的供货和代理分销网络。我们专业代理经销、开发生产电子元器件、集成电路、传感器、微波光电元器件、工控机/DOC/DOM 电子盘、专用电路、单片机开发、MCU/DSP/ARM/FPGA 软件硬件、二极管、三极管、模块等，是您可靠的一站式现货配套供应商、方案提供商、部件功能模块开发配套商。商斯达实业公司拥有庞大的资料库，有数位毕业于著名高校——有中国电子工业摇篮之称的西安电子科技大学（西军电）并长期从事国防尖端科技研究的高级工程师为您精挑细选、量身订做各种高科技电子元器件，并解决各种技术问题。

微波光电部专业代理经销高频、微波、光纤、光电元器件、组件、部件、模块、整机；电磁兼容元器件、材料、设备；微波 CAD、EDA 软件、开发测试仿真工具；微波、光纤仪器仪表。欢迎国外高科技微波、光纤厂商将优秀产品介绍到中国、共同开拓市场。长期大量现货专业批发高频、微波、卫星、光纤、电视、CATV 器件：晶振、VCO、连接器、PIN 开关、变容二极管、开关二极管、低噪晶体管、功率电阻及电容、放大器、功率管、MMIC、混频器、耦合器、功分器、振荡器、合成器、衰减器、滤波器、隔离器、环行器、移相器、调制解调器；光电子元件和组件：红外发射管、红外接收管、光电开关、光敏管、发光二极管和发光二极管组件、半导体激光二极管和激光器组件、光电探测器和光接收组件、光发射接收模块、光纤激光器和光放大器、光调制器、光开关、DWDM 用光发射和接收器件、用户接入系统光收发器件与模块、光纤连接器、光纤跳线/尾纤、光衰减器、光纤适配器、光隔离器、光耦合器、光环行器、光复用器/转换器；无线收发芯片和模组、蓝牙芯片和模组。

更多产品请看本公司产品专用销售网站：

商斯达中国传感器科技信息网：<http://www.sensor-ic.com/>

商斯达工控安防网：<http://www.pc-ps.net/>

商斯达电子元器件网：<http://www.sunstare.com/>

商斯达微波光电产品网：[HTTP://www.rfoe.net/](http://www.rfoe.net/)

商斯达消费电子产品网：[//www.icasic.com/](http://www.icasic.com/)

商斯达实业科技产品网：[//www.sunstars.cn/](http://www.sunstars.cn/) 微波元器件销售热线：

地址：深圳市福田区福华路福庆街鸿图大厦 1602 室

电话：0755-82884100 83397033 83396822 83398585

传真：0755-83376182 (0) 13823648918 MSN: SUNS8888@hotmail.com

邮编：518033 E-mail:[szss20@163.com](mailto:szss20@163.com) QQ: 195847376

深圳赛格展销部：深圳华强北路赛格电子市场 2583 号 电话：0755-83665529 25059422

技术支持：0755-83394033 13501568376

欢迎索取免费详细资料、设计指南和光盘；产品凡多，未能尽录，欢迎来电查询。

北京分公司：北京海淀区知春路 132 号中发电子大厦 3097 号

TEL: 010-81159046 82615020 13501189838 FAX: 010-62543996

上海分公司：上海市北京东路 668 号上海赛格电子市场 D125 号

TEL: 021-28311762 56703037 13701955389 FAX: 021-56703037

西安分公司：西安高新开发区 20 所(中国电子科技集团导航技术研究所)

西安劳动南路 88 号电子商城二楼 D23 号

TEL: 029-81022619 13072977981 FAX:029-88789382