



Two-Terminal IC Temperature Transducer

AD590

FEATURES

Linear Current Output: 1 $\mu\text{A/K}$
Wide Range: -55°C to $+150^{\circ}\text{C}$
Probe Compatible Ceramic Sensor Package
Two Terminal Device: Voltage In/Current Out
Laser Trimmed to $\pm 0.5^{\circ}\text{C}$ Calibration Accuracy (AD590M)
Excellent Linearity: $\pm 0.3^{\circ}\text{C}$ Over Full Range (AD590M)
Wide Power Supply Range: +4 V to +30 V
Sensor Isolation from Case
Low Cost

PIN DESIGNATIONS

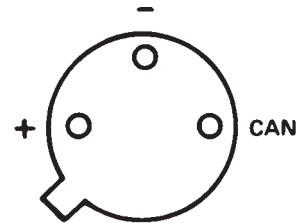

BOTTOM VIEW

PRODUCT DESCRIPTION

The AD590 is a two-terminal integrated circuit temperature transducer that produces an output current proportional to absolute temperature. For supply voltages between +4 V and +30 V the device acts as a high impedance, constant current regulator passing 1 $\mu\text{A/K}$. Laser trimming of the chip's thin-film resistors is used to calibrate the device to 298.2 μA output at 298.2K ($+25^{\circ}\text{C}$).

The AD590 should be used in any temperature sensing application below $+150^{\circ}\text{C}$ in which conventional electrical temperature sensors are currently employed. The inherent low cost of a monolithic integrated circuit combined with the elimination of support circuitry makes the AD590 an attractive alternative for many temperature measurement situations. Linearization circuitry, precision voltage amplifiers, resistance measuring circuitry and cold junction compensation are not needed in applying the AD590.

In addition to temperature measurement, applications include temperature compensation or correction of discrete components, biasing proportional to absolute temperature, flow rate measurement, level detection of fluids and anemometry. The AD590 is available in chip form making it suitable for hybrid circuits and fast temperature measurements in protected environments.

The AD590 is particularly useful in remote sensing applications. The device is insensitive to voltage drops over long lines due to its high impedance current output. Any well insulated twisted pair is sufficient for operation hundreds of feet from the receiving circuitry. The output characteristics also make the AD590 easy to multiplex: the current can be switched by a CMOS multiplexer or the supply voltage can be switched by a logic gate output.

REV. B

Information furnished by Analog Devices is believed to be accurate and reliable. However, no responsibility is assumed by Analog Devices for its use, nor for any infringements of patents or other rights of third parties which may result from its use. No license is granted by implication or otherwise under any patent or patent rights of Analog Devices.

PRODUCT HIGHLIGHTS

1. The AD590 is a calibrated two terminal temperature sensor requiring only a dc voltage supply (+4 V to +30 V). Costly transmitters, filters, lead wire compensation and linearization circuits are all unnecessary in applying the device.
2. State-of-the-art laser trimming at the wafer level in conjunction with extensive final testing ensures that AD590 units are easily interchangeable.
3. Superior interface rejection results from the output being a current rather than a voltage. In addition, power requirements are low (1.5 mWs @ 5 V @ $+25^{\circ}\text{C}$.) These features make the AD590 easy to apply as a remote sensor.
4. The high output impedance ($>10\text{ M}\Omega$) provides excellent rejection of supply voltage drift and ripple. For instance, changing the power supply from 5 V to 10 V results in only a 1 μA maximum current change, or 1°C equivalent error.
5. The AD590 is electrically durable: it will withstand a forward voltage up to 44 V and a reverse voltage of 20 V. Hence, supply irregularities or pin reversal will not damage the device.

AD590—SPECIFICATIONS (@ +25°C and $V_S = +5\text{ V}$ unless otherwise noted)

Model	AD590J			AD590K			Units
	Min	Typ	Max	Min	Typ	Max	
ABSOLUTE MAXIMUM RATINGS							
Forward Voltage (E+ or E-)			+44			+44	Volts
Reverse Voltage (E+ to E-)			-20			-20	Volts
Breakdown Voltage (Case E+ or E-)			±200			±200	Volts
Rated Performance Temperature Range ¹	-55		+150	-55		+150	°C
Storage Temperature Range ¹	-65		+155	-65		+155	°C
Lead Temperature (Soldering, 10 sec)			+300			+300	°C
POWER SUPPLY							
Operating Voltage Range	+4		+30	+4		+30	Volts
OUTPUT							
Nominal Current Output @ +25°C (298.2K)		298.2			298.2		μA
Nominal Temperature Coefficient		1			1		μA/K
Calibration Error @ +25°C			±5.0			±2.5	°C
Absolute Error (Over Rated Performance Temperature Range)							
Without External Calibration Adjustment			±10			±5.5	°C
With +25°C Calibration Error Set to Zero			±3.0			±2.0	°C
Nonlinearity			±1.5			±0.8	°C
Repeatability ²			±0.1			±0.1	°C
Long-Term Drift ³			±0.1			±0.1	°C
Current Noise		40			40		pA/√Hz
Power Supply Rejection							
+4 V ≤ V_S ≤ +5 V		0.5			0.5		μA/V
+5 V ≤ V_S ≤ +15 V		0.2			0.2		μV/V
+15 V ≤ V_S ≤ +30 V		0.1			0.1		μA/V
Case Isolation to Either Lead		10 ¹⁰			10 ¹⁰		Ω
Effective Shunt Capacitance		100			100		pF
Electrical Turn-On Time		20			20		μs
Reverse Bias Leakage Current ⁴ (Reverse Voltage = 10 V)		10			10		pA
PACKAGE OPTIONS							
TO-52 (H-03A)		AD590JH			AD590KH		
Flatpack (F-2A)		AD590JF			AD590KF		

NOTES

¹The AD590 has been used at -100°C and +200°C for short periods of measurement with no physical damage to the device. However, the absolute errors specified apply to only the rated performance temperature range.

²Maximum deviation between +25°C readings after temperature cycling between -55°C and +150°C; guaranteed not tested.

³Conditions: constant +5 V, constant +125°C; guaranteed, not tested.

⁴Leakage current doubles every 10°C.

Specifications subject to change without notice.

Specifications shown in **boldface** are tested on all production units at final electrical test. Results from those tests are used to calculate outgoing quality levels. All min and max specifications are guaranteed, although only those shown in **boldface** are tested on all production units.

AD590

Model	AD590L			AD590M			Units
	Min	Typ	Max	Min	Typ	Max	
ABSOLUTE MAXIMUM RATINGS							
Forward Voltage (E+ or E-)			+44			+44	Volts
Reverse Voltage (E+ to E-)			-20			-20	Volts
Breakdown Voltage (Case to E+ or E-)			±200			±200	Volts
Rated Performance Temperature Range ¹	-55		+150	-55		+150	°C
Storage Temperature Range ¹	-65		+155	-65		+155	°C
Lead Temperature (Soldering, 10 sec)			+300			+300	°C
POWER SUPPLY							
Operating Voltage Range	+4		+30	+4		+30	Volts
OUTPUT							
Nominal Current Output @ +25°C (298.2K)		298.2			298.2		µA
Nominal Temperature Coefficient		1			1		µA/K
Calibration Error @ +25°C			±1.0			±0.5	°C
Absolute Error (Over Rated Performance Temperature Range)							
Without External Calibration Adjustment			±3.0			±1.7	°C
With ±25°C Calibration Error Set to Zero			±1.6			±1.0	°C
Nonlinearity			±0.4			±0.3	°C
Repeatability ²			±0.1			±0.1	°C
Long-Term Drift ³			±0.1			±0.1	°C
Current Noise		40			40		pA/√Hz
Power Supply Rejection							
+4 V ≤ V _S ≤ +5 V		0.5			0.5		µA/V
+5 V ≤ V _S ≤ +15 V		0.2			0.2		µA/V
+15 V ≤ V _S ≤ +30 V		0.1			0.1		µA/V
Case Isolation to Either Lead		10 ¹⁰			10 ¹⁰		Ω
Effective Shunt Capacitance		100			100		pF
Electrical Turn-On Time		20			20		µs
Reverse Bias Leakage Current ⁴ (Reverse Voltage = 10 V)		10			10		pA
PACKAGE OPTIONS							
TO-52 (H-03A)		AD590LH			AD590MH		
Flatpack (F-2A)		AD590LF			AD590MF		

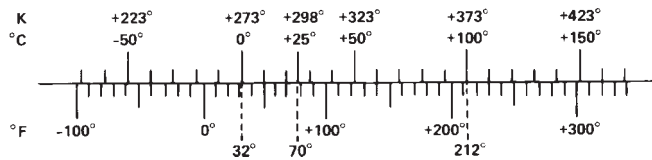

TEMPERATURE SCALE CONVERSION EQUATIONS

$$^{\circ}C = \frac{5}{9} (^{\circ}F - 32) \quad K = ^{\circ}C + 273.15$$

$$^{\circ}F = \frac{9}{5} ^{\circ}C + 32 \quad ^{\circ}R = ^{\circ}F + 459.7$$

AD590

The 590H has 60 μ inches of gold plating on its Kovar leads and Kovar header. A resistance welder is used to seal the nickel cap to the header. The AD590 chip is eutectically mounted to the header and ultrasonically bonded to with 1 MIL aluminum wire. Kovar composition: 53% iron nominal; 29% ± 1% nickel; 17% ± 1% cobalt; 0.65% manganese max; 0.20% silicon max; 0.10% aluminum max; 0.10% magnesium max; 0.10% zirconium max; 0.10% titanium max; 0.06% carbon max.

The 590F is a ceramic package with gold plating on its Kovar leads, Kovar lid, and chip cavity. Solder of 80/20 Au/Sn composition is used for the 1.5 mil thick solder ring under the lid. The chip cavity has a nickel underlay between the metalization and the gold plating. The AD590 chip is eutectically mounted in the chip cavity at 410°C and ultrasonically bonded to with 1 mil aluminum wire. Note that the chip is in direct contact with the ceramic base, not the metal lid. When using the AD590 in die form, the chip substrate must be kept electrically isolated, (floating), for correct circuit operation.

METALIZATION DIAGRAM

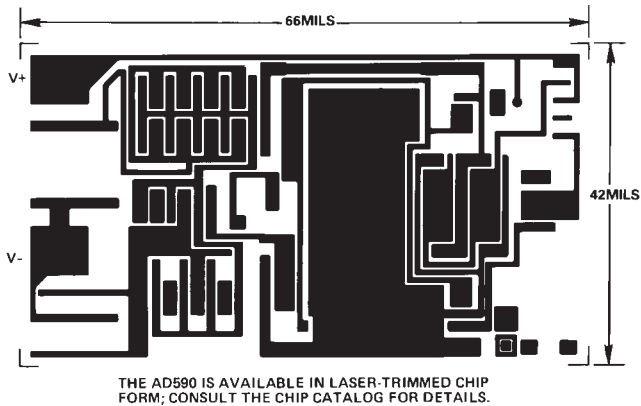

CIRCUIT DESCRIPTION¹

The AD590 uses a fundamental property of the silicon transistors from which it is made to realize its temperature proportional characteristic: if two identical transistors are operated at a constant ratio of collector current densities, r , then the difference in their base-emitter voltage will be $(kT/q)(\ln r)$. Since both k , Boltzman's constant and q , the charge of an electron, are constant, the resulting voltage is directly proportional to absolute temperature (PTAT).

In the AD590, this PTAT voltage is converted to a PTAT current by low temperature coefficient thin-film resistors. The total current of the device is then forced to be a multiple of this PTAT current. Referring to Figure 1, the schematic diagram of the AD590, Q8 and Q11 are the transistors that produce the PTAT voltage. R5 and R6 convert the voltage to current. Q10, whose collector current tracks the collector currents in Q9 and Q11, supplies all the bias and substrate leakage current for the rest of the circuit, forcing the total current to be PTAT. R5 and R6 are laser trimmed on the wafer to calibrate the device at +25°C.

Figure 2 shows the typical V-I characteristic of the circuit at +25°C and the temperature extremes.

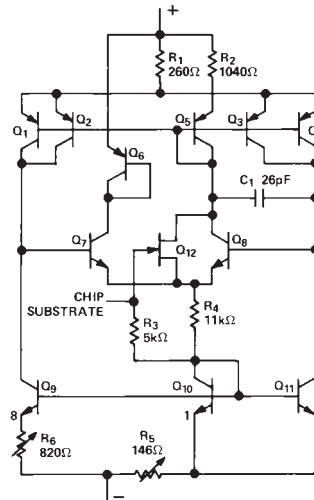

Figure 1. Schematic Diagram

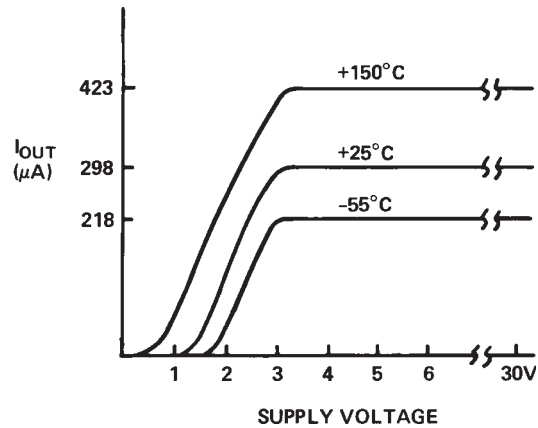

Figure 2. V-I Plot

¹For a more detailed circuit description see M.P. Timko, "A Two-Terminal IC Temperature Transducer," IEEE J. Solid State Circuits, Vol. SC-11, p. 784-788, Dec. 1976.

Understanding the Specifications—AD590

EXPLANATION OF TEMPERATURE SENSOR SPECIFICATIONS

The way in which the AD590 is specified makes it easy to apply in a wide variety of different applications. It is important to understand the meaning of the various specifications and the effects of supply voltage and thermal environment on accuracy.

The AD590 is basically a PTAT (proportional to absolute temperature)¹ current regulator. That is, the output current is equal to a scale factor times the temperature of the sensor in degrees Kelvin. This scale factor is trimmed to 1 $\mu\text{A}/\text{K}$ at the factory, by adjusting the indicated temperature (i.e., the output current) to agree with the actual temperature. This is done with 5 V across the device at a temperature within a few degrees of +25°C (298.2K). The device is then packaged and tested for accuracy over temperature.

CALIBRATION ERROR

At final factory test the difference between the indicated temperature and the actual temperature is called the calibration error. Since this is a scale factory error, its contribution to the total error of the device is PTAT. For example, the effect of the 1°C specified maximum error of the AD590L varies from 0.73°C at -55°C to 1.42°C at 150°C. Figure 3 shows how an exaggerated calibration error would vary from the ideal over temperature.

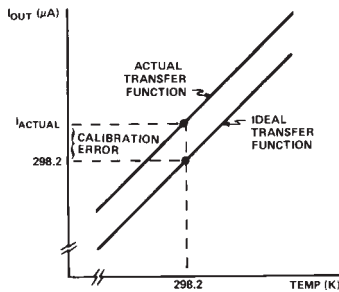

Figure 3. Calibration Error vs. Temperature

The calibration error is a primary contributor to maximum total error in all AD590 grades. However, since it is a scale factor error, it is particularly easy to trim. Figure 4 shows the most elementary way of accomplishing this. To trim this circuit the temperature of the AD590 is measured by a reference temperature sensor and R is trimmed so that $V_T = 1 \text{ mV}/\text{K}$ at that temperature. Note that when this error is trimmed out at one temperature, its effect is zero over the entire temperature range. In most applications there is a current-to-voltage conversion resistor (or, as with a current input ADC, a reference) that can be trimmed for scale factor adjustment.

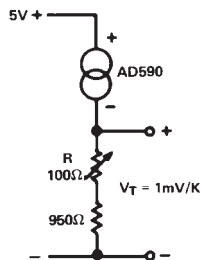

Figure 4. One Temperature Trim

¹T(°C) = T(K) - 273.2; Zero on the Kelvin scale is "absolute zero"; there is no lower temperature.

ERROR VERSUS TEMPERATURE: WITH CALIBRATION ERROR TRIMMED OUT

Each AD590 is tested for error over the temperature range with the calibration error trimmed out. This specification could also be called the "variance from PTAT" since it is the maximum difference between the actual current over temperature and a PTAT multiplication of the actual current at 25°C. This error consists of a slope error and some curvature, mostly at the temperature extremes. Figure 5 shows a typical AD590K temperature curve before and after calibration error trimming.

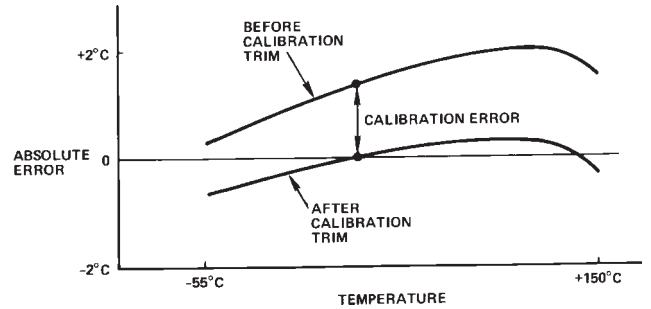

Figure 5. Effect to Scale Factor Trim on Accuracy

ERROR VERSUS TEMPERATURE: NO USER TRIMS

Using the AD590 by simply measuring the current, the total error is the "variance from PTAT" described above plus the effect of the calibration error over temperature. For example the AD590L maximum total error varies from 2.33°C at -55°C to 3.02°C at 150°C. For simplicity, only the large figure is shown on the specification page.

NONLINEARITY

Nonlinearity as it applies to the AD590 is the maximum deviation of current over temperature from a best-fit straight line. The nonlinearity of the AD590 over the -55°C to +150°C range is superior to all conventional electrical temperature sensors such as thermocouples, RTDs and thermistors. Figure 6 shows the nonlinearity of the typical AD590K from Figure 5.

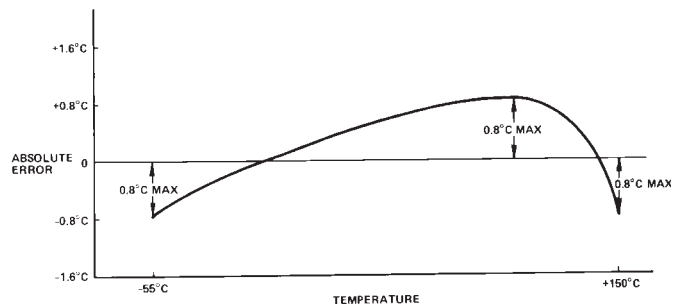

Figure 6. Nonlinearity

Figure 7A shows a circuit in which the nonlinearity is the major contributor to error over temperature. The circuit is trimmed by adjusting R_1 for a 0 V output with the AD590 at 0°C. R_2 is then adjusted for 10 V out with the sensor at 100°C. Other pairs of temperatures may be used with this procedure as long as they are measured accurately by a reference sensor. Note that for +15 V output (150°C) the V_+ of the op amp must be greater than 17 V. Also note that V_- should be at least -4 V; if V_- is ground there is no voltage applied across the device.

AD590

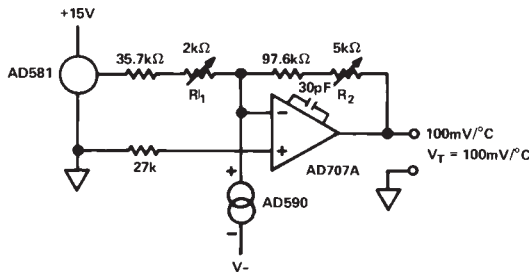

Figure 7A. Two Temperature Trim

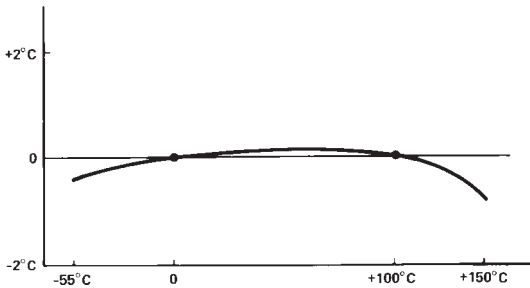

Figure 7B. Typical Two-Trim Accuracy

VOLTAGE AND THERMAL ENVIRONMENT EFFECTS

The power supply rejection specifications show the maximum expected change in output current versus input voltage changes. The insensitivity of the output to input voltage allows the use of unregulated supplies. It also means that hundreds of ohms of resistance (such as a CMOS multiplexer) can be tolerated in series with the device.

It is important to note that using a supply voltage other than 5 V does not change the PTAT nature of the AD590. In other words, this change is equivalent to a calibration error and can be removed by the scale factor trim (see previous page).

The AD590 specifications are guaranteed for use in a low thermal resistance environment with 5 V across the sensor. Large changes in the thermal resistance of the sensor's environment will change the amount of self-heating and result in changes in the output which are predictable but not necessarily desirable.

The thermal environment in which the AD590 is used determines two important characteristics: the effect of self heating and the response of the sensor with time.

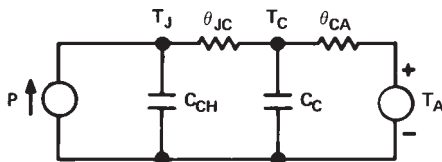

Figure 8. Thermal Circuit Model

Figure 8 is a model of the AD590 which demonstrates these characteristics. As an example, for the TO-52 package, θ_{JC} is the thermal resistance between the chip and the case, about 26°C/watt. θ_{CA} is the thermal resistance between the case and the surroundings and is determined by the characteristics of the

thermal connection. Power source P represents the power dissipated on the chip. The rise of the junction temperature, T_J , above the ambient temperature T_A is:

$$T_J - T_A = P(\theta_{JC} + \theta_{CA}) \quad \text{Equation 1}$$

Table I gives the sum of θ_{JC} and θ_{CA} for several common thermal media for both the "H" and "F" packages. The heatsink used was a common clip-on. Using Equation 1, the temperature rise of an AD590 "H" package in a stirred bath at +25°C, when driven with a 5 V supply, will be 0.06°C. However, for the same conditions in still air the temperature rise is 0.72°C. For a given supply voltage, the temperature rise varies with the current and is PTAT. Therefore, if an application circuit is trimmed with the sensor in the same thermal environment in which it will be used, the scale factor trim compensates for this effect over the entire temperature range.

Table I. Thermal Resistances

Medium	$\theta_{JC} + \theta_{CA}$ (°C/Watt)		τ (sec)(Note 3)	
	H	F	H	F
Aluminum Block	30	10	0.6	0.1
Stirred Oil ¹	42	60	1.4	0.6
Moving Air ²				
With Heat Sink	45	-	5.0	-
Without Heat Sink	115	190	13.5	10.0
Still Air				
With Heat Sink	191	-	108	-
Without Heat Sink	480	650	60	30

¹Note: τ is dependent upon velocity of oil; average of several velocities listed above.

²Air velocity \approx 9 ft./sec.

³The time constant is defined as the time required to reach 63.2% of an instantaneous temperature change.

The time response of the AD590 to a step change in temperature is determined by the thermal resistances and the thermal capacities of the chip, C_{CH} , and the case, C_C . C_{CH} is about 0.04 watt-sec/°C for the AD590. C_C varies with the measured medium since it includes anything that is in direct thermal contact with the case. In most cases, the single time constant exponential curve of Figure 9 is sufficient to describe the time response, $T(t)$. Table I shows the effective time constant, τ , for several media.

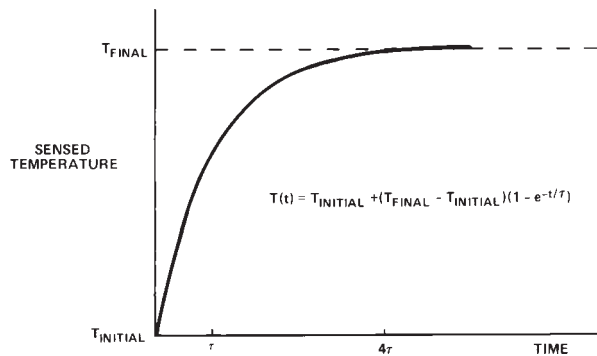

Figure 9. Time Response Curve

Applying the AD590

GENERAL APPLICATIONS

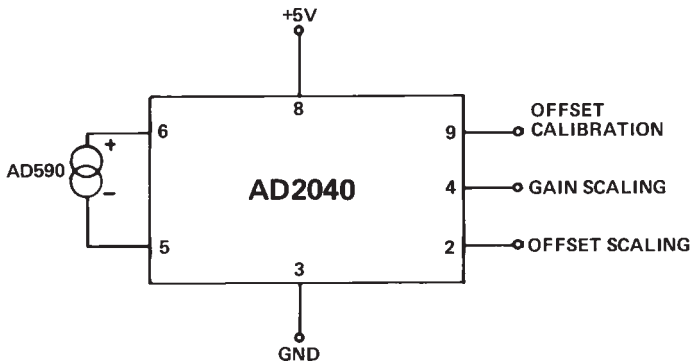

Figure 10. Variable Scale Display

Figure 10 demonstrates the use of a low cost Digital Panel Meter for the display of temperature on either the Kelvin, Celsius or Fahrenheit scales. For Kelvin temperature Pins 9, 4 and 2 are grounded; and for Fahrenheit temperature Pins 4 and 2 are left open.

The above configuration yields a 3 digit display with 1°C or 1°F resolution, in addition to an absolute accuracy of $\pm 2.0^\circ\text{C}$ over the -55°C to $+125^\circ\text{C}$ temperature range if a one-temperature calibration is performed on an AD590K, L, or M.

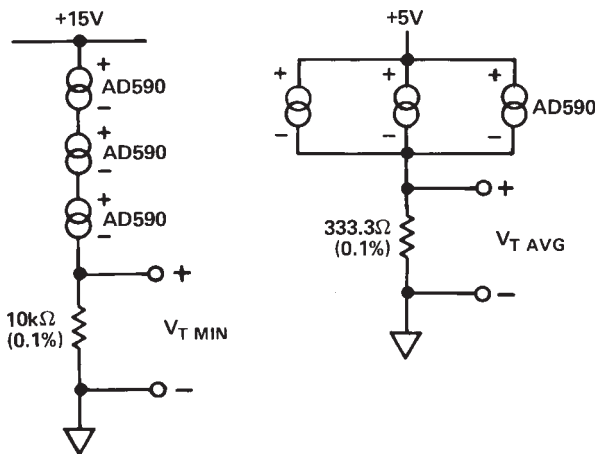

Figure 11. Series & Parallel Connection

Connecting several AD590 units in series as shown in Figure 11 allows the minimum of all the sensed temperatures to be indicated. In contrast, using the sensors in parallel yields the average of the sensed temperatures.

The circuit of Figure 12 demonstrates one method by which differential temperature measurements can be made. R1 and R2 can be used to trim the output of the op amp to indicate a

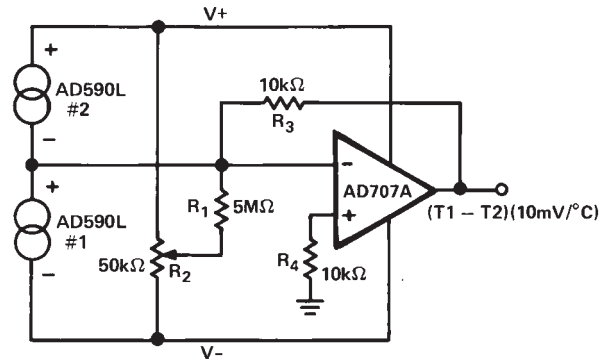

Figure 12. Differential Measurements

desired temperature difference. For example, the inherent offset between the two devices can be trimmed in. If V+ and V- are radically different, then the difference in internal dissipation will cause a differential internal temperature rise. This effect can be used to measure the ambient thermal resistance seen by the sensors in applications such as fluid level detectors or anemometry.

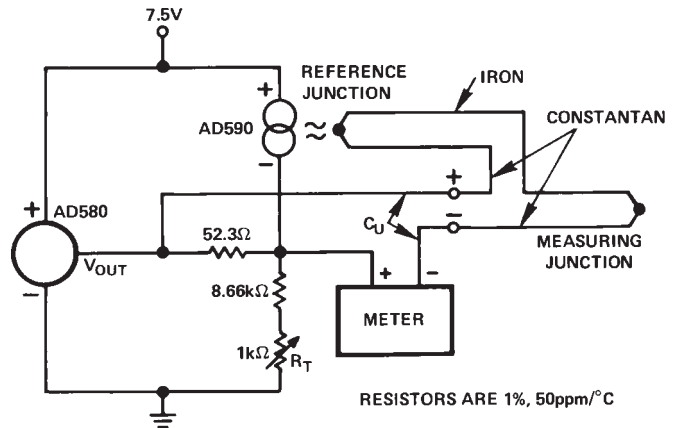

Figure 13. Cold Junction Compensation Circuit for Type J Thermocouple

Figure 13 is an example of a cold junction compensation circuit for a Type J Thermocouple using the AD590 to monitor the reference junction temperature. This circuit replaces an ice-bath as the thermocouple reference for ambient temperatures between $+15^\circ\text{C}$ and $+35^\circ\text{C}$. The circuit is calibrated by adjusting R_T for a proper meter reading with the measuring junction at a known reference temperature and the circuit near $+25^\circ\text{C}$. Using components with the TCs as specified in Figure 13, compensation accuracy will be within $\pm 0.5^\circ\text{C}$ for circuit temperatures between $+15^\circ\text{C}$ and $+35^\circ\text{C}$. Other thermocouple types can be accommodated with different resistor values. Note that the TCs of the voltage reference and the resistors are the primary contributors to error.

AD590

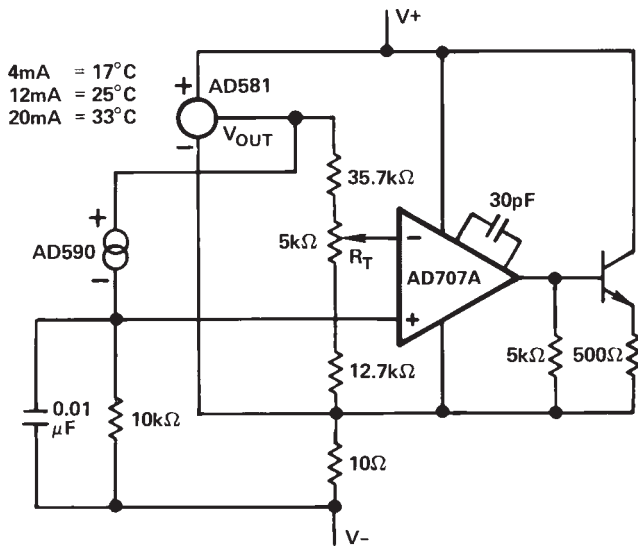

Figure 14. 4 mA-to-20 mA Current Transmitter

Figure 14 is an example of a current transmitter designed to be used with 40 V, 1 kΩ systems; it uses its full current range of 4 mA-to-20 mA for a narrow span of measured temperatures. In this example the 1 μA/K output of the AD590 is amplified to 1 mA/°C and offset so that 4 mA is equivalent to 17°C and 20 mA is equivalent to 33°C. R_T is trimmed for proper reading at an intermediate reference temperature. With a suitable choice of resistors, any temperature range within the operating limits of the AD590 may be chosen.

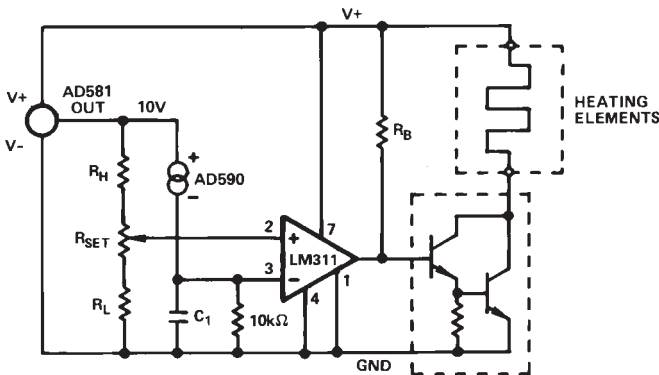

Figure 15. Simple Temperature Control Circuit

Figure 15 is an example of a variable temperature control circuit (thermostat) using the AD590. R_H and R_L are selected to set the high and low limits for R_{SET} . R_{SET} could be a simple pot, a calibrated multiturn pot or a switched resistive divider. Powering the AD590 from the 10 V reference isolates the AD590 from supply variations while maintaining a reasonable voltage (~7 V) across it. Capacitor C_1 is often needed to filter extraneous noise from remote sensors. R_B is determined by the β of the power transistor and the current requirements of the load.

Figure 16 shows the AD590 can be configured with an 8-bit DAC to produce a digitally controlled set point. This particular circuit operates from 0°C (all inputs high) to +51°C (all inputs

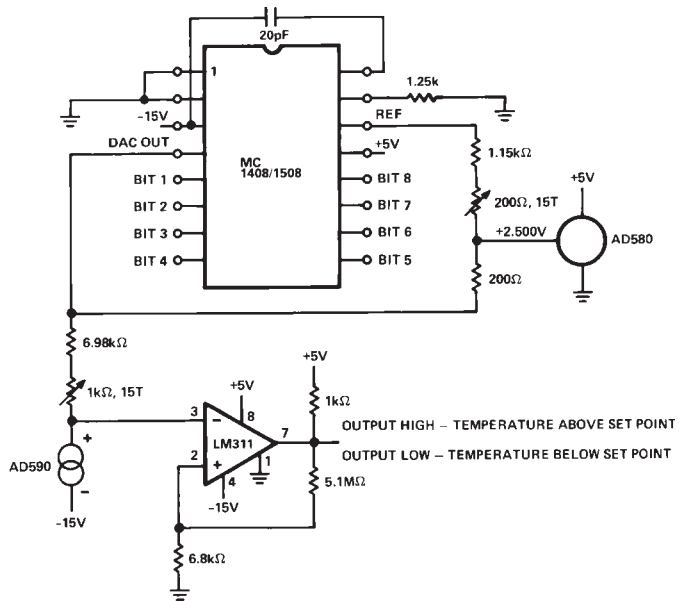

Figure 16. DAC Set Point

low) in 0.2°C steps. The comparator is shown with 1°C hysteresis which is usually necessary to guard-band for extraneous noise; omitting the 5.1 MΩ resistor results in no hysteresis.

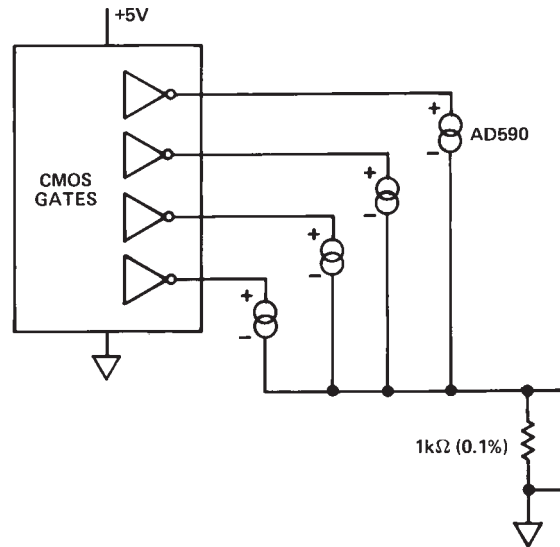

Figure 17. AD590 Driven from CMOS Logic

The voltage compliance and the reverse blocking characteristic of the AD590 allows it to be powered directly from +5 V CMOS logic. This permits easy multiplexing, switching or pulsing for minimum internal heat dissipation. In Figure 17 any AD590s connected to a logic high will pass a signal current through the current measuring circuitry while those connected to a logic zero will pass insignificant current. The outputs used to drive the AD590s may be employed for other purposes, but the additional capacitance due to the AD590 should be taken into account.

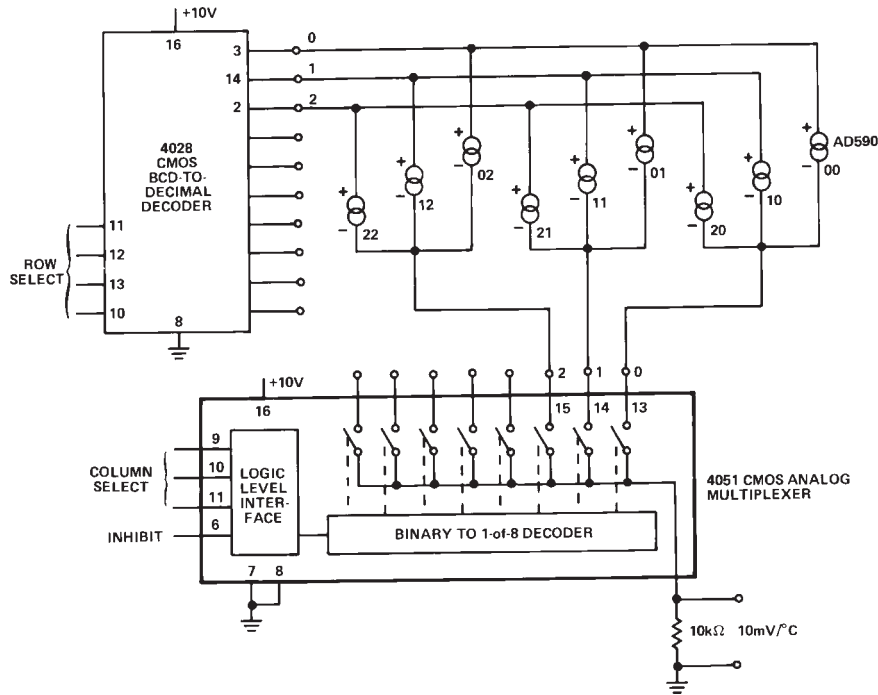

Figure 18. Matrix Multiplexer

CMOS Analog Multiplexers can also be used to switch AD590 current. Due to the AD590's current mode, the resistance of such switches is unimportant as long as 4 V is maintained across the transducer. Figure 18 shows a circuit which combines the principal demonstrated in Figure 17 with an 8-channel CMOS Multiplexer. The resulting circuit can select one of eighty sensors over only 18 wires with a 7-bit binary word. The inhibit input on the multiplexer turns all sensors off for minimum dissipation while idling.

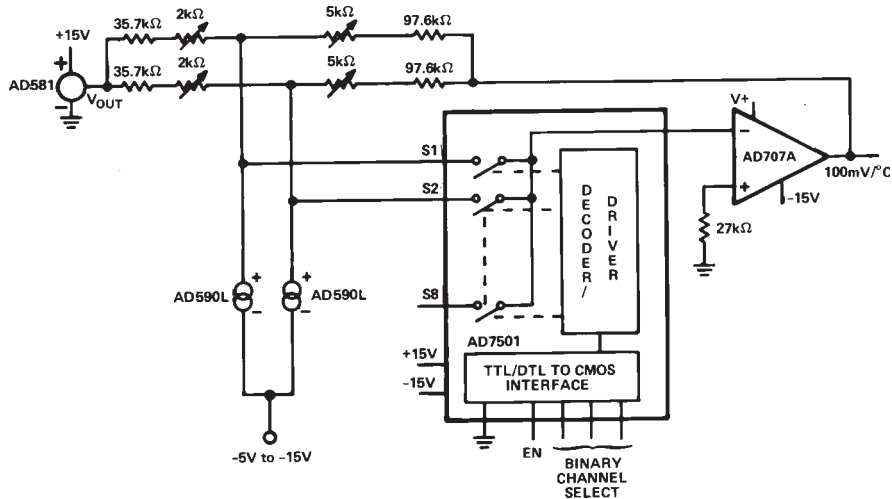

Figure 19. 8-Channel Multiplexer

Figure 19 demonstrates a method of multiplexing the AD590 in the two-trim mode (Figure 7). Additional AD590s and their associated resistors can be added to multiplex up to 8 channels of $\pm 0.5^\circ\text{C}$ absolute accuracy over the temperature range of -55°C to $+125^\circ\text{C}$. The high temperature restriction of $+125^\circ\text{C}$ is due to the output range of the op amps; output to $+150^\circ\text{C}$ can be achieved by using a $+20\text{ V}$ supply for the op amp.

AD590

OUTLINE DIMENSIONS AND PIN DESIGNATIONS

Dimensions shown in inches and (mm).

FLATPACK PACKAGE: DESIGNATION "F"

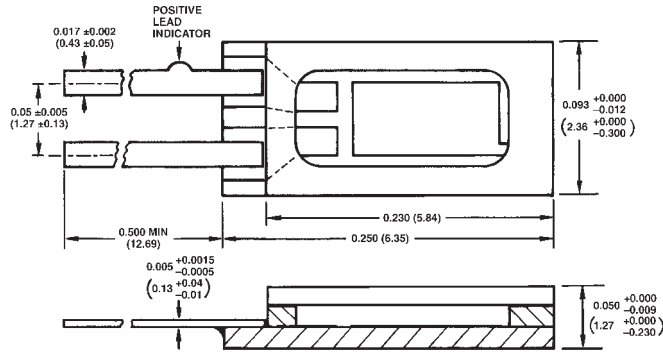

TO-52 Package: Designation "H"

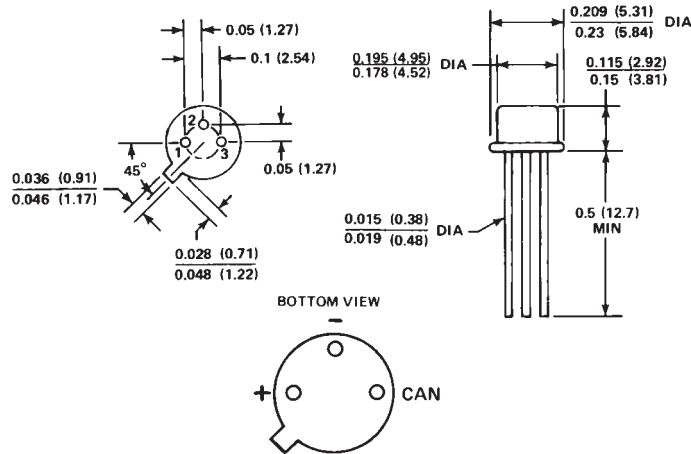

SUNSTAR商斯达实业集团是集研发、生产、工程、销售、代理经销、技术咨询、信息服务等为一体的高科技企业，是专业高科技电子产品生产厂家，是具有 10 多年历史的专业电子元器件供应商，是中国最早和最大的仓储式连锁规模经营大型综合电子零部件代理分销商之一，是一家专业代理和分销世界各大品牌 IC 芯片和电子元器件的连锁经营综合性国际公司。在香港、北京、深圳、上海、西安、成都等全国主要电子市场设有直属分公司和产品展示展销窗口门市部专卖店及代理分销商，已在全国范围内建成强大统一的供货和代理分销网络。我们专业代理经销、开发生产电子元器件、集成电路、传感器、微波光电元器件、工控机/DOC/DOM 电子盘、专用电路、单片机开发、MCU/DSP/ARM/FPGA 软件硬件、二极管、三极管、模块等，是您可靠的一站式现货配套供应商、方案提供商、部件功能模块开发配套商。专业以现代信息产业（计算机、通讯及传感器）三大支柱之一的传感器为主营业务，专业经营各类传感器的代理、销售生产、网络信息、科技图书资料及配套产品设计、工程开发。我们的专业网站——中国传感器科技信息网（全球传感器数据库）www.SENSOR-IC.COM 服务于全球高科技生产商及贸易商，为企业科技产品开发提供技术交流平台。欢迎各厂商互通有无、交换信息、交换链接、发布寻求代理信息。欢迎国外高科技传感器、变送器、执行器、自动控制产品厂商介绍产品到中国，共同开拓市场。本网站是关于各种传感器-变送器-仪器仪表及工业自动化大型专业网站，深入到工业控制、系统工程计 测量、自动化、安防报警、消费电子等众多领域，把最新的传感器-变送器-仪器仪表买卖信息，最新技术供求，最新采购商，行业动态，发展方向，最新的技术应用和市场资讯及时的传递给广大科技开发、科学研究、产品设计人员。本网站已成功为石油、化工、电力、医药、生物、航空、航天、国防、能源、冶金、电子、工业、农业、交通、汽车、矿山、煤炭、纺织、信息、通信、IT、安防、环保、印刷、科研、气象、仪器仪表等领域从事科学研究、产品设计、开发、生产制造的科技人员、管理人员、和采购人员提供满意服务。我们公司专业生产、代理、经销、销售各种传感器、变送器、敏感元器件、开关、执行器、仪器仪表、自动化控制系统：专门从事设计、生产、销售各种传感器、变送器、各种测控仪表、热工仪表、现场控制器、计算机控制系统、数据采集系统、各类环境监控系统、专用控制系统应用软件以及嵌入式系统开发及应用等工作。如热敏电阻、压敏电阻、温度传感器、温度变送器、湿度传感器、湿度变送器、气体传感器、气体变送器、压力传感器、压力变送、称重传感器、物（液）位传感器、物（液）位变送器、流量传感器、流量变送器、电流（压）传感器、溶氧传感器、霍尔传感器、图像传感器、超声波传感器、位移传感器、速度传感器、加速度传感器、扭距传感器、红外传感器、紫外传感器、火焰传感器、激光传感器、振动传感器、轴角传感器、光电传感器、接近传感器、干簧管传感器、继电器传感器、微型电泵、磁敏（阻）传感器、压力开关、接近开关、光电开关、色标传感器、光纤传感器、齿轮测速传感器、时间继电器、计数器、计米器、温控仪、固态继电器、调压模块、电磁铁、电压表、电流表等特殊传感器。同时承接传感器应用电路、产品设计和自动化工程项目。

更多产品请看本公司产品专用销售网站：

商斯达中国传感器科技信息网：<http://www.sensor-ic.com/>

商斯达工控安防网：<http://www.pc-ps.net/>

商斯达电子元器件网：<http://www.sunstare.com/>

商斯达微波光电产品网：[HTTP://www.rfoe.net/](http://www.rfoe.net/)

商斯达消费电子产品网：<http://www.icasic.com/>

商斯达军工产品网：<http://www.junpinic.com/>

商斯达实业科技产品网：<http://www.sunstars.cn/> 传感器销售热线：

地址：深圳市福田区福华路福庆街鸿图大厦 1602 室

电话：0755-83607652 83376489 83376549 83370250 83370251 82500323

传真：0755-83376182 (0) 13902971329 MSN: SUNS888@hotmail.com

邮编：518033 E-mail: szss20@163.com QQ: 195847376

深圳赛格展销部：深圳华强北路赛格电子市场 2583 号 电话：0755-83665529 25059422

技术支持：0755-83394033 13501568376

欢迎索取免费详细资料、设计指南和光盘；产品凡多，未能尽录，欢迎来电查询。

北京分公司：北京海淀区知春路 132 号中发电子大厦 3097 号

TEL: 010-81159046 82615020 13501189838 FAX: 010-62543996

上海分公司：上海市北京东路 668 号上海赛格电子市场 D125 号

TEL: 021-28311762 56703037 13701955389 FAX: 021-56703037

西安分公司：西安高新开发区 20 所(中国电子科技集团导航技术研究所)

西安劳动南路 88 号电子商城二楼 D23 号

TEL: 029-81022619 13072977981 FAX:029-88789382