

June 1999

# LM77

## 9-Bit + Sign Digital Temperature Sensor and Thermal Window Comparator with Two-Wire Interface

### General Description

The LM77 is a digital temperature sensor and thermal window comparator with an I<sup>2</sup>C™ Serial Bus interface. The window-comparator architecture of the LM77 eases the design of temperature control systems conforming to the ACPI (Advanced Configuration and Power Interface) specification for personal computers. The open-drain Interrupt (INT) output becomes active whenever temperature goes outside a programmable window, while a separate Critical Temperature Alarm (T\_CRIT\_A) output becomes active when the temperature exceeds a programmable critical limit. The INT output can operate in either a comparator or event mode, while the T\_CRIT\_A output operates in comparator mode only.

The host can program both the upper and lower limits of the window as well as the critical temperature limit. Programmable hysteresis as well as a fault queue are available to minimize false tripping. Two pins (A0, A1) are available for address selection. The sensor powers up with default thresholds of 2°C T<sub>HYST</sub>, 10°C T<sub>LOW</sub>, 64°C T<sub>HIGH</sub>, and 80°C T<sub>CRIT</sub>.

The LM77's 3.0V to 5.5V supply voltage range, Serial Bus interface, 9-bit + sign output, and full-scale range of over 128°C make it ideal for a wide range of applications. These include thermal management and protection applications in personal computers, electronic test equipment, office electronics, automotive, and HVAC applications.

### Features

- Window comparison simplifies design of ACPI compatible temperature monitoring and control.
- Serial Bus interface
- Separate open-drain outputs for Interrupt and Critical Temperature shutdown
- Shutdown mode to minimize power consumption
- Up to 4 LM77s can be connected to a single bus
- 9-bit + sign output; full-scale reading of over 128°C

### Key Specifications

■ Supply Voltage		3.0V to 5.5V
■ Supply Current	operating	250 μA (typ)
		500 μA (max)
	shutdown	5 μA (typ)
■ Temperature Accuracy	-10°C to 65°C	±1.5°C(max)
	-25°C to 100°C	±2°C(max)
	-55°C to 125°C	±3°C(max)

### Applications

- System Thermal Management
- Personal Computers
- Office Electronics
- Electronic Test Equipment
- Automotive
- HVAC

### Simplified Block Diagram

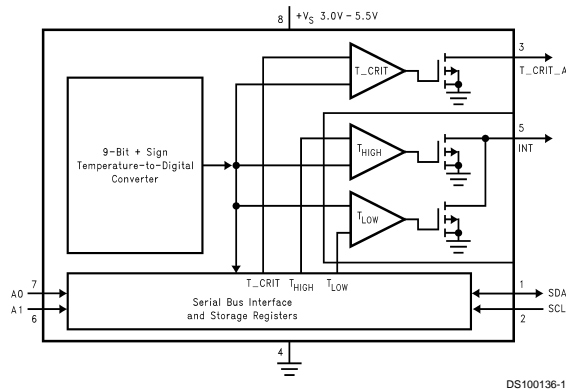

I<sup>2</sup>C® is a registered trademark of Philips Corporation.

LM77 9-Bit + Sign Digital Temperature Sensor and Thermal Window Comparator with Two-Wire Interface

## Connection Diagram

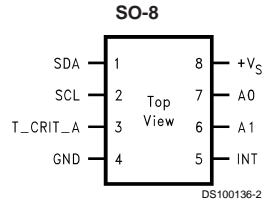

LM77 See NS Package Number M08A

## Ordering Information

Order Number	Supply Voltage	Supplied As
LM77CIM-3	3.3V	
LM77CIMX-3	3.3V	2500 Units on Tape and Reel
LM77CIM-5	5V	
LM77CIMX-5	5V	2500 Units on Tape and Reel

## Pin Description

Label	Pin #	Function	Typical Connection
SDA	1	Serial Bi-Directional Data Line. Open Drain Output	From Controller
SCL	2	Serial Bus Clock Input	From Controller
T_CRIT_A	3	Critical Temperature Alarm Open Drain Output	Pull Up Resistor, Controller Interrupt Line or System Hardware Shutdown
GND	4	Power Supply Ground	Ground
INT	5	Interrupt Open Drain Output	Pull Up Resistor, Controller Interrupt Line
+V <sub>S</sub>	8	Positive Supply Voltage Input	DC Voltage from 3V to 5.5V
A0-A1	7,6	User-Set Address Inputs	Ground (Low, "0") or +V <sub>S</sub> (High, "1")

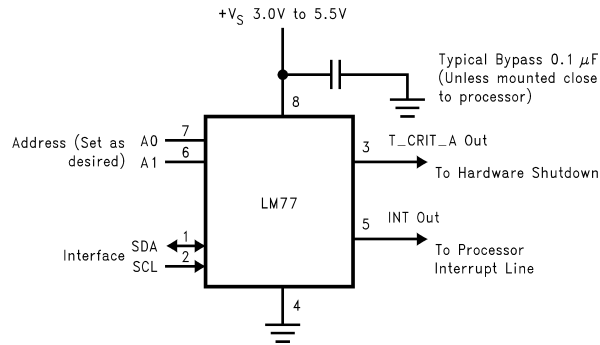

FIGURE 1. Typical Application

DS100136-3

### Absolute Maximum Ratings (Note 1)

Supply Voltage	-0.3V to 6.5V
Voltage at any Pin	-0.3V to (+V <sub>S</sub> + 0.3V)
Input Current at any Pin	5 mA
Package Input Current (Note 2)	20 mA
T_CRIT_A and INT Output Sink Current	10 mA
T_CRIT_A and INT Output Voltage	6.5V
Storage Temperature	-65°C to +125°C

Soldering Information, Lead Temperature

SOP and MSOP Package (Note 3)

Vapor Phase (60 seconds) 215°C

Infrared (15 seconds) 220°C

ESD Susceptibility (Note 4)

Human Body Model 2500V

Machine Model 250V

### Operating Ratings (Notes 1, 5)

Specified Temperature Range (Note 6)

T<sub>MIN</sub> to T<sub>MAX</sub>  
-55°C to +125°C

Supply Voltage Range (+V<sub>S</sub>)(Note 7) +3.0V to +5.5V

### Temperature-to-Digital Converter Characteristics

Unless otherwise noted, these specifications apply for +V<sub>S</sub>=+5 Vdc ±10% for LM77CIM-5 and +V<sub>S</sub>=+3.3 Vdc ±10% for LM77CIM-3 (Note 7). **Boldface limits apply for T<sub>A</sub> = T<sub>J</sub> = T<sub>MIN</sub> to T<sub>MAX</sub>**; all other limits T<sub>A</sub>= T<sub>J</sub>=+25°C, unless otherwise noted.

Parameter	Conditions	Typical (Note 8)	Limits (Note 9)	Units (Limit)
Accuracy	T <sub>A</sub> = -10°C to +65°C		<b>±1.5</b>	°C (max)
	T <sub>A</sub> = -25°C to +100°C		<b>±2.0</b>	
	T <sub>A</sub> = -55°C to +125°C		<b>±3.0</b>	
Resolution	(Note 10)	10		Bits
		0.5		°C
Temperature Conversion Time	(Note 11)	70	<b>125</b>	ms
Quiescent Current	I <sup>2</sup> C Inactive	0.25		mA
	I <sup>2</sup> C Active	0.25	<b>0.5</b>	mA (max)
	Shutdown Mode	5	<b>10</b>	µA
T <sub>HYST</sub> Default Temperature	(Notes 13, 14)	2		°C
T <sub>LOW</sub> Default Temperature	(Note 14)	10		°C
T <sub>HIGH</sub> Default Temperature	(Note 14)	64		°C
T <sub>C</sub> Default Temperature	(Note 14)	80		°C

### Logic Electrical Characteristics

**DIGITAL DC CHARACTERISTICS** Unless otherwise noted, these specifications apply for +V<sub>S</sub>=+5 Vdc ±10% for LM77CIM-5 and +V<sub>S</sub>=+3.3 Vdc ±10% for LM77CIM-3. **Boldface limits apply for T<sub>A</sub> = T<sub>J</sub> = T<sub>MIN</sub> to T<sub>MAX</sub>**; all other limits T<sub>A</sub>= T<sub>J</sub>=+25°C, unless otherwise noted.

Symbol	Parameter	Conditions	Typical (Note 8)	Limits (Note 9)	Units (Limit)
V <sub>IN(1)</sub>	SDA and SCL Logical "1" Input Voltage			<b>+V<sub>S</sub> x 0.7</b>	V (min)
				<b>+V<sub>S</sub>+0.3</b>	V (max)
V <sub>IN(0)</sub>	SDA and SCL Logical "0" Input Voltage			<b>-0.3</b>	V (min)
				<b>+V<sub>S</sub> x 0.3</b>	V (max)
V <sub>IN(1)</sub>	A0 and A1 Logical "1" Input Voltage			<b>2.0</b>	V (min)
				<b>+V<sub>S</sub>+0.3</b>	V (max)
V <sub>IN(0)</sub>	A0 and A1 Logical "0" Input Voltage			<b>-0.3</b>	V (min)
				<b>0.8</b>	V (max)
I <sub>IN(1)</sub>	Logical "1" Input Current	V <sub>IN</sub> = +V <sub>S</sub>	0.005	<b>1.0</b>	µA (max)
I <sub>IN(0)</sub>	Logical "0" Input Current	V <sub>IN</sub> = 0V	-0.005	<b>-1.0</b>	µA (max)
C <sub>IN</sub>	Capacitance of All Digital Inputs		20		pF

**Logic Electrical Characteristics** (Continued)

**DIGITAL DC CHARACTERISTICS** Unless otherwise noted, these specifications apply for +V<sub>S</sub>=+5 Vdc ±10% for LM77CIM-5 and +V<sub>S</sub>=+3.3 Vdc ±10% for LM77CIM-3. **Boldface limits apply for T<sub>A</sub> = T<sub>J</sub> = T<sub>MIN</sub> to T<sub>MAX</sub>**; all other limits T<sub>A</sub>= T<sub>J</sub>=+25°C, unless otherwise noted.

Symbol	Parameter	Conditions	Typical (Note 8)	Limits (Note 9)	Units (Limit)
I <sub>OH</sub>	High Level Output Current	V <sub>OH</sub> = + V <sub>S</sub>		<b>10</b>	μA (max)
V <sub>OL</sub>	Low Level Output Voltage	I <sub>OL</sub> = 3 mA		<b>0.4</b>	V (max)
	T_CRIT_A Output Saturation Voltage	I <sub>OUT</sub> = 4.0 mA (Note 12)		<b>0.8</b>	V (max)
	T_CRIT_A Delay			<b>1</b>	Conversions (max)
t <sub>OF</sub>	Output Fall Time	C <sub>L</sub> = 400 pF I <sub>O</sub> = 3 mA		<b>250</b>	ns (max)

### Logic Electrical Characteristics (Continued)

**SERIAL BUS DIGITAL SWITCHING CHARACTERISTICS** Unless otherwise noted, these specifications apply for  $+V_S=+5$  Vdc  $\pm 10\%$  for LM77CIM-5,  $+V_S=+3.3$  Vdc  $\pm 10\%$  for LM77CIM-3, CL (load capacitance) on output lines = 80 pF unless otherwise specified. Boldface limits apply for  $T_A = T_J = T_{MIN}$  to  $T_{MAX}$ ; all other limits  $T_A = T_J = +25^\circ\text{C}$ , unless otherwise noted. The switching characteristics of the LM77 fully meet or exceed the published specifications of the I<sup>2</sup>C bus. The following parameters are the timing relationship between SCL and SDA signal related to the LM77. They are not the I<sup>2</sup>C bus specifications.

Symbol	Parameter	Conditions	Typical (Note 8)	Limits (Note 9)	Units (Limit)
$t_1$	SCL (Clock) Period			<b>2.5</b>	$\mu\text{s}(\text{min})$
$t_2$	Data in Set-Up Time to SCL High			<b>100</b>	ns(min)
$t_3$	Data Out Stable after SCL Low			<b>0</b>	ns(min)
$t_4$	SDA Low Set-Up Time to SCL Low (Start Condition)			<b>100</b>	ns(min)
$t_5$	SDA High Hold Time after SCL High (Stop Condition)			<b>100</b>	ns(min)

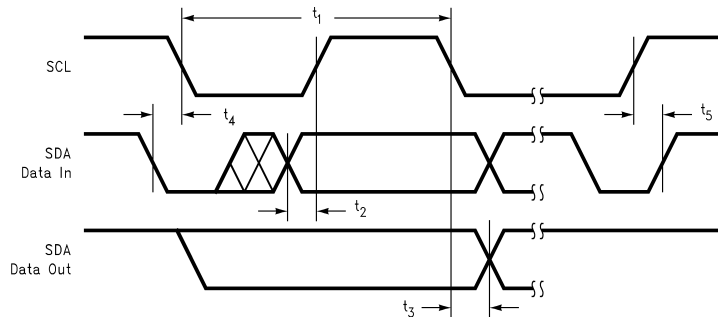

DS100136-4

**Note 1:** Absolute Maximum Ratings indicate limits beyond which damage to the device may occur. DC and AC electrical specifications do not apply when operating the device beyond its rated operating conditions.

**Note 2:** When the input voltage ( $V_I$ ) at any pin exceeds the power supplies ( $V_I < \text{GND}$  or  $V_I > +V_S$ ) the current at that pin should be limited to 5 mA. The 20 mA maximum package input current rating limits the number of pins that can safely exceed the power supplies with an input current of 5 mA to four.

**Note 3:** See AN-450 "Surface Mounting Methods and Their Effect on Product Reliability" or the section titled "Surface Mount" found in a current National Semiconductor Linear Data Book for other methods of soldering surface mount devices.

**Note 4:** Human body model, 100 pF discharged through a 1.5 k $\Omega$  resistor. Machine model, 200 pF discharged directly into each pin.

**Note 5:** LM77  $\theta_{JA}$  (thermal resistance, junction-to-ambient) when attached to a printed circuit board with 2 oz. foil is 200 $^\circ\text{C}/\text{W}$ .

**Note 6:** While the LM77 has a full-scale-range in excess of 128 $^\circ\text{C}$ , prolonged operation at temperatures above 125 $^\circ\text{C}$  is not recommended.

**Note 7:** Both part numbers of the LM77 will operate properly over the  $+V_S$  supply voltage range of 3V to 5.5V. The devices are tested and specified for rated accuracy at their nominal supply voltage. Accuracy will typically degrade 1 $^\circ\text{C}/\text{V}$  of variation in  $+V_S$  as it varies from the nominal value.

**Note 8:** Typical values are at  $T_A = 25^\circ\text{C}$  and represent most likely parametric norm.

**Note 9:** Limits are guaranteed to National's AOQL (Average Outgoing Quality Level).

**Note 10:** 9 bits + sign, two's complement

**Note 11:** This specification is provided only to indicate how often temperature data is updated. The LM77 can be read at any time without regard to conversion state (and will yield last conversion result). If a conversion is in process it will be interrupted and restarted after the end of the read.

**Note 12:** For best accuracy, minimize output loading. Higher sink currents can affect sensor accuracy with internal heating. This can cause an error of 0.64 $^\circ\text{C}$  at full rated sink current and saturation voltage based on junction-to-ambient thermal resistance.

**Note 13:** Hysteresis value adds to the  $T_{LOW}$  setpoint value (e.g.: if  $T_{LOW}$  setpoint = 10 $^\circ\text{C}$ , and hysteresis = 2 $^\circ\text{C}$ , then actual hysteresis point is 10+2 = 12 $^\circ\text{C}$ ); and subtracts from the  $T_{HIGH}$  and  $T_{CRIT}$  setpoints (e.g.: if  $T_{HIGH}$  setpoint = 64 $^\circ\text{C}$ , and hysteresis = 2 $^\circ\text{C}$ , then actual hysteresis point is 64-2 = 62 $^\circ\text{C}$ ). For a detailed discussion of the function of hysteresis refer to Section 1.1, TEMPERATURE COMPARISON, and Figure 3.

**Note 14:** Default values set at power up.

## Logic Electrical Characteristics (Continued)

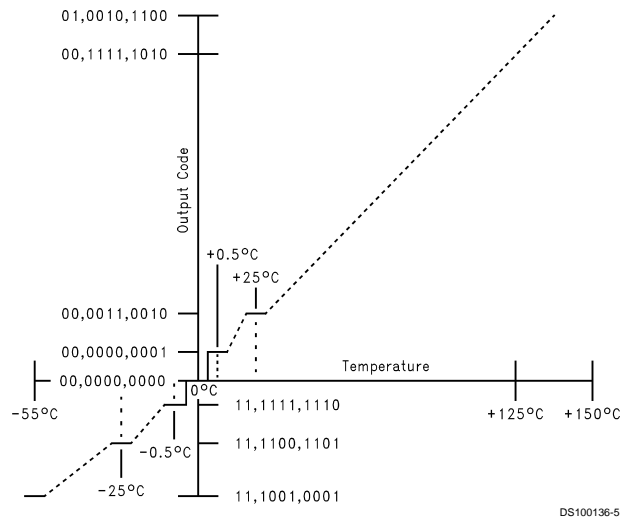

FIGURE 2. Temperature-to-Digital Transfer Function (Non-linear scale for clarity)

## 1.0 Functional Description

The LM77 temperature sensor incorporates a band-gap type temperature sensor, 10-bit ADC, and a digital comparator with user-programmable upper and lower limit values. The comparator activates either the INT line for temperatures outside the  $T_{LOW}$  and  $T_{HIGH}$  window, or the  $T_{CRIT\_A}$  line for temperatures which exceed  $T_{CRIT}$ . The lines are programmable for mode and polarity.

### 1.1 TEMPERATURE COMPARISON

LM77 provides a window comparison against a lower ( $T_{LOW}$ ) and upper ( $T_{HIGH}$ ) trip point. A second upper trip point ( $T_{CRIT}$ ) functions as a critical alarm shutdown. Figure 3 depicts the comparison function as well as the modes of operation.

#### 1.1.1 STATUS BITS

The internal Status bits operate as follows:

**“True”:** Temperature above a  $T_{HIGH}$  or  $T_{CRIT}$  is “true” for those respective bits. A “true” for  $T_{LOW}$  is temperature below  $T_{LOW}$ .

**“False”:** Assuming temperature has previously crossed above  $T_{HIGH}$  or  $T_{CRIT}$ , then the temperature must drop below the points corresponding  $T_{HYST}$  ( $T_{HIGH} - T_{HYST}$  or  $T_{CRIT} - T_{HYST}$ ) in order for the condition to be false. For  $T_{LOW}$ , assuming temperature has previously crossed below  $T_{LOW}$ , a “false” occurs when temperature goes above  $T_{LOW} + T_{HYST}$ .

The Status bits are not affected by reads or any other actions, and always represent the state of temperature vs. setpoints.

#### 1.1.2 HARDWARE OUTPUTS

The  $T_{CRIT\_A}$  hardware output mirrors the  $T_{CRIT\_A}$  flag, when the flag is true, the  $T_{CRIT\_A}$  output is asserted at all times regardless of mode. Reading the LM77 has no effect on the  $T_{CRIT\_A}$  output, although the internal conversion is restarted.

The behavior of the INT hardware output is as follows:

**Comparator Interrupt Mode (Default):** User reading part resets output until next measurement completes. If condition is still true, output is set again at end of next conversion cycle. For example, if a user never reads the part, and temperature goes below  $T_{LOW}$  then INT becomes active. It would stay that way until temperature goes above  $T_{LOW} + T_{HYST}$ . However if the user reads the part, the output would be reset. At the end of the next conversion cycle, if the condition is true, it is set again. If not, it remains reset.

**Event Interrupt Mode:** User reading part resets output until next condition “event” occurs (in other words, output is only set once for a true condition, if reset by a read, it remains reset until the next triggering threshold has been crossed). Conversely, if a user never read the part, the output would stay set indefinitely after the first event that set the output. An “event” for Event Interrupt Mode is defined as:

1. Transitioning upward across a setpoint, or
2. Transitioning downward across a setpoint’s corresponding hysteresis (after having exceeded that setpoint).

For example, if a user never read the part, and temperature went below  $T_{LOW}$  then INT would become active. It would stay that way forever if a user never read the part.

However if the user read the part, the output would be reset. Even if the condition is true, it will remain reset. The temperature must cross above  $T_{LOW} + T_{HYST}$  to set the output again.

In either mode, reading any register in the LM77 restarts the conversion. This allows a designer to know exactly when the LM77 begins a comparison. This prevents unnecessary Interrupts just after reprogramming setpoints. Typically, system Interrupt inputs are masked prior to reprogramming trip points. By doing a read just after resetting trip points, but prior to unmasking, unexpected Interrupts are prevented.

Avoid programming setpoints so close that their hysteresis values overlap. An example would be that with a  $T_{HYST}$  value

## 1.0 Functional Description (Continued)

of 2°C then setting  $T_{HIGH}$  and  $T_{LOW}$  to within 4°C of each other will violate this restriction. To be more specific, with  $T_{HYST}$  set to 2°C assume  $T_{HIGH}$  set to 64°C. If  $T_{LOW}$  is set equal to, or higher than 60°C this restriction is violated.

### 1.2 DEFAULT SETTINGS

The LM77 always powers up in a known state. LM77 power up default conditions are:

1. Comparator Interrupt Mode
2.  $T_{LOW}$  set to 10°C
3.  $T_{HIGH}$  set to 64°C
4.  $T_{CRIT}$  set to 80°C
5.  $T_{HYST}$  set to 2°C
6. INT and  $T_{CRIT\_A}$  active low
7. Pointer set to "00"; Temperature Register

The LM77 registers will always reset to these default values when the power supply voltage is brought up from zero volts as the supply crosses the voltage level plotted in the following curve. The LM77 registers will reset again when the power supply drops below the voltage plotted in this curve.

**Average Power on Reset Voltage vs Temperature**

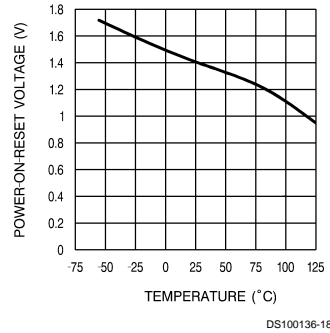

### 1.3 SERIAL BUS INTERFACE

The LM77 operates as a slave on the Serial Bus, so the SCL line is an input (no clock is generated by the LM77) and the SDA line is a bi-directional serial data line. According to Serial Bus specifications, the LM77 has a 7-bit slave address. The five most significant bits of the slave address are hard wired inside the LM77 and are "10010". The two least significant bits of the address are assigned to pins A1–A0, and are set by connecting these pins to ground for a low, (0); or to +V<sub>S</sub> for a high, (1).

Therefore, the complete slave address is:

1	0	0	1	0	A1	A0
MSB					LSB	

## 1.0 Functional Description (Continued)

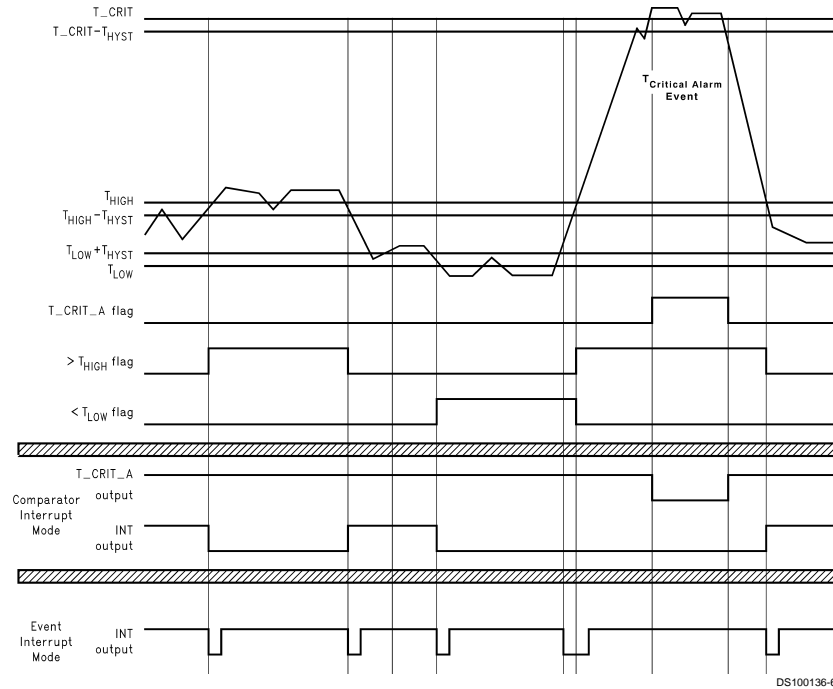

Note: Event Interrupt mode is drawn as if the user is reading the part. If the user doesn't read, the outputs would go low and stay that way until the LM77 is read.

FIGURE 3. Temperature Response Diagram

### 1.4 TEMPERATURE DATA FORMAT

Temperature data can be read from the Temperature and Set Point registers; and written to the Set Point registers. Temperature data can be read at any time, although reading faster than the conversion time of the LM77 will prevent data from being updated. Temperature data is represented by a 10-bit, two's complement word with an LSB (Least Significant Bit) equal to 0.5°C:

Temperature	Digital Output	
	Binary	Hex
+130°C	01 0000 0100	104h
+125°C	00 1111 1010	0FAh
+25°C	00 0011 0010	032h
+0.5°C	00 0000 0001	001h
0°C	00 0000 0000	000h
-0.5°C	11 1111 1111	3FFh
-25°C	11 1100 1110	3CEh
-55°C	11 1001 0010	392h

### 1.5 SHUTDOWN MODE

Shutdown mode is enabled by setting the shutdown bit in the Configuration register via the Serial Bus. Shutdown mode reduces power supply current to 5 µA typical. T\_CRIT\_A is re-

set if previously set. Since conversions are stopped during shutdown, T\_CRIT\_A and INT will not be operational. The Serial Bus interface remains active. Activity on the clock and data lines of the Serial Bus may slightly increase shutdown mode quiescent current. Registers can be read from and written to in shutdown mode. The LM77 takes milliseconds to respond to the shutdown command.

### 1.6 INT AND T\_CRIT\_A OUTPUT

The INT and T\_CRIT\_A outputs are open-drain outputs and do not have internal pull-ups. A "high" level will not be observed on these pins until pull-up current is provided from some external source, typically a pull-up resistor. Choice of resistor value depends on many system factors but, in general, the pull-up resistor should be as large as possible. This will minimize any errors due to internal heating of the LM77. The maximum resistance of the pull up, based on LM77 specification for High Level Output Current, to provide a 2 volt high level, is 30K ohms.

### 1.7 FAULT QUEUE

A fault queue of up to 4 faults is provided to prevent false tripping when the LM77 is used in noisy environments. The 4 faults must occur consecutively to set flags as well as INT and T\_CRIT\_A outputs. The fault queue is enabled by setting bit 4 of the Configuration Register high (see Section 1.11).



## 1.0 Functional Description (Continued)

### 1.8 INTERNAL REGISTER STRUCTURE

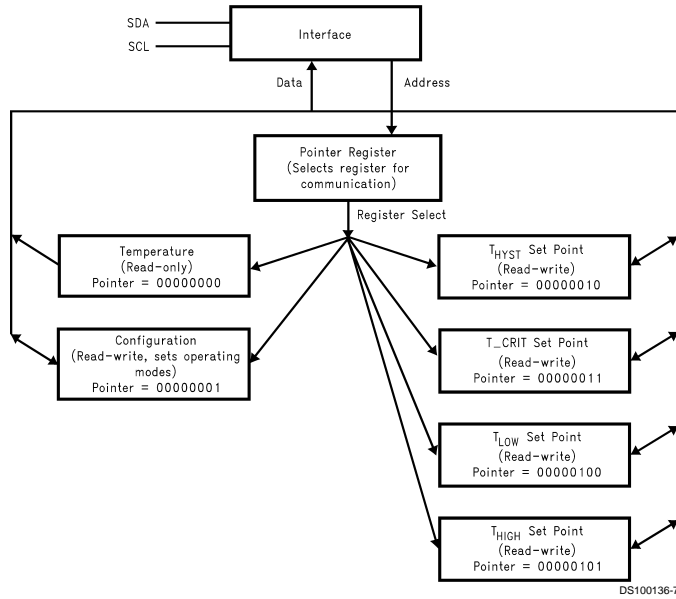

There are four data registers in the LM77, selected by the Pointer register. At power-up the Pointer is set to "00"; the location for the Temperature Register. The Pointer register latches the last location it was set to. In Interrupt Mode, a read from the LM77 resets the INT output. Placing the device in Shutdown mode resets the INT and T\_CRIT\_A outputs. All registers are read and write, except the Temperature register which is read only.

A write to the LM77 will always include the address byte and the Pointer byte. A write to the Configuration register requires one data byte, while the T<sub>LOW</sub>, T<sub>HIGH</sub>, and T<sub>CRIT</sub> registers require two data bytes.

Reading the LM77 can take place either of two ways: If the location latched in the Pointer is correct (most of the time it is expected that the Pointer will point to the Temperature register because it will be the data most frequently read from the LM77), then the read can simply consist of an address byte,

followed by retrieving the corresponding number of data bytes. If the Pointer needs to be set, then an address byte, pointer byte, repeat start, and another address byte plus required number of data bytes will accomplish a read.

The first data byte is the most significant byte with most significant bit first, permitting only as much data as necessary to be read to determine the temperature condition. For instance, if the first four bits of the temperature data indicates a critical condition, the host processor could immediately take action to remedy the excessive temperature. At the end of a read, the LM77 can accept either Acknowledge or No Acknowledge from the Master (No Acknowledge is typically used as a signal for the slave that the Master has read its last byte).

An inadvertent 8-bit read from a 16-bit register, with the D7 bit low, can cause the LM77 to stop in a state where the SDA line is held low as shown in Figure 4. This can prevent any further bus communication until at least 9 additional clock cycles have occurred. Alternatively, the master can issue clock cycles until SDA goes high, at which time issuing a "Stop" condition will reset the LM77.

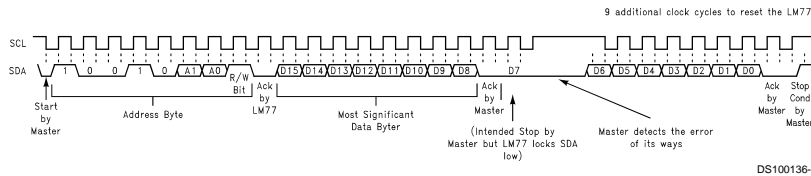

FIGURE 4. Inadvertent 8-Bit Read from 16-Bit Register where D7 is Zero ("0")

## 1.0 Functional Description (Continued)

### 1.9 POINTER REGISTER

(Selects which registers will be read from or written to):

P7	P6	P5	P4	P3	P2	P1	P0
0	0	0	0	0	Register Select		

P0–P2: Register Select:

P2	P1	P0	Register
0	0	0	Temperature (Read only) (Power-up default)
0	0	1	Configuration (Read/Write)
0	1	0	T <sub>HYST</sub> (Read/Write)
0	1	1	T <sub>CRIT</sub> (Read/Write)
1	0	0	T <sub>LOW</sub> (Read/Write)
1	0	1	T <sub>HIGH</sub> (Read/Write)

P3–P7: Must be kept zero.

### 1.10 TEMPERATURE REGISTER

(Read Only):

D15	D14	D13	D12	D11	D10	D9	D8	D7	D6	D5	D4	D3	D2	D1	D0
Sign	Sign	Sign	Sign	MSB	Bit 7	Bit 6	Bit 5	Bit 4	Bit 3	Bit 2	Bit 1	Bit 0	CRIT	HIGH	LOW
													Status Bits		

D0–D2: Status Bits

D3–D15: Temperature Data. One LSB = 0.5°C. Two's complement format.

### 1.11 CONFIGURATION REGISTER

(Read/Write):

D7	D6	D5	D4	D3	D2	D1	D0
0	0	0	Fault Queue	INT Polarity	T <sub>CRIT_A</sub> Polarity	INT Mode	Shutdown

D0: Shutdown - When set to 1 the LM77 goes to low power shutdown mode. Power up default of "0".

D1: Interrupt mode - 0 is Comparator Interrupt mode, 1 is Event Interrupt mode. Power up default of "0".

D2, D3: T<sub>CRIT\_A</sub> and INT Polarity - 0 is active low, 1 is active high. Outputs are open-drain. Power up default of "0"

D4: Fault Queue - When set to 1 the Fault Queue is enabled, see *Section 1.7*. Power up default of "0".

D5–D7: These bits are used for production testing and must be kept zero for normal operation.

### 1.12 T<sub>HYST</sub>, T<sub>LOW</sub>, T<sub>HIGH</sub> AND T<sub>CRIT\_A</sub> REGISTERS

(Read/Write):

D15	D14	D13	D12	D11	D10	D9	D8	D7	D6	D5	D4	D3	D2	D1	D0
Sign	Sign	Sign	Sign	MSB	Bit7	Bit6	Bit5	Bit 4	Bit 3	Bit 2	Bit 1	Bit 0	X	X	X

D0–D2: Undefined

D3–D15: T<sub>HYST</sub>, T<sub>LOW</sub>, T<sub>HIGH</sub> or T<sub>CRIT</sub> Trip Temperature Data. Power up default is T<sub>LOW</sub> = 10°C, T<sub>HIGH</sub> = 64°C, T<sub>CRIT</sub> = 80°C, T<sub>HYST</sub> = 2°C.

T<sub>HYST</sub> is subtracted from T<sub>HIGH</sub>, and T<sub>CRIT</sub>, and added to T<sub>LOW</sub>.

Avoid programming setpoints so close that their hysteresis values overlap. See *Section 1.1*.

## 2.0 I<sup>2</sup>C Timing Diagrams

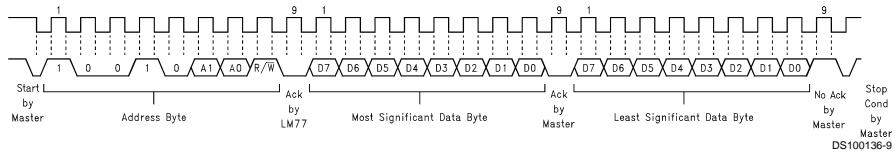

Typical 2-Byte Read From Preset Pointer Location Such as Temp or Comparison Registers

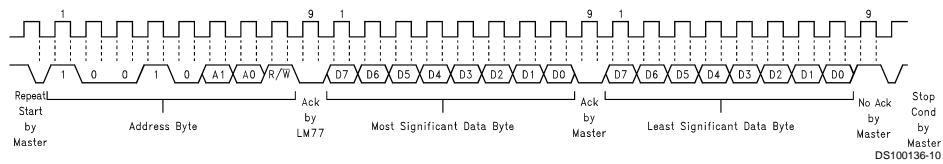
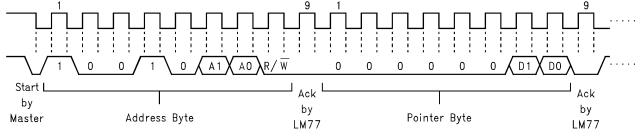

Typical Pointer Set Followed by Immediate Read for 2-Byte Register such as Temp or Comparison Registers

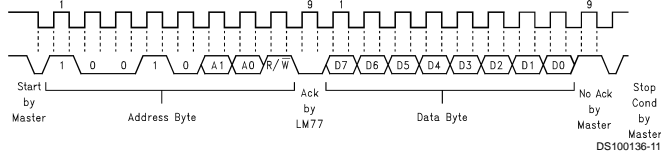

Typical 1-Byte Read from Configuration Register with Preset Pointer

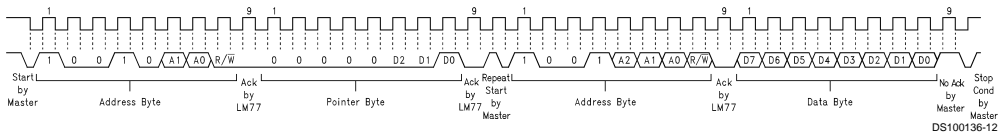

Typical Pointer Set Followed by Immediate Read from Configuration Register

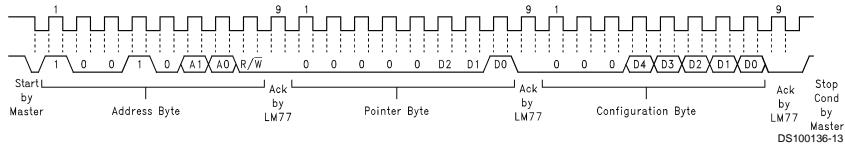

Configuration Register Write

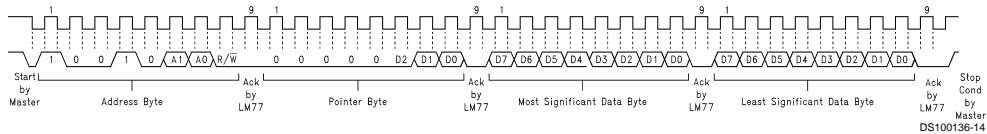

Comparison Register Write

FIGURE 6. Timing Diagrams

### 3.0 Application Hints

The temperature response graph in *Figure 7* depicts a typical application designed to meet ACPI requirements. In this type of application, the temperature scale is given an arbitrary value of "granularity", or the window within which temperature notification events should occur. The LM77 can be programmed to the window size chosen by the designer, and will issue interrupts to the processor whenever the window limits have been crossed. The internal flags permit quick determination of whether the temperature is rising or falling.

The T\_CRIT limit would typically use its separate output to activate hardware shutdown circuitry separate from the processor. This is done because it is expected that if temperature has gotten this high that the processor may not be responding. The separate circuitry can then shut down the system, usually by shutting down the power supply.

Note that the INT and T\_CRIT\_A outputs are separate, but can be wire-or'd together. Alternatively the T\_CRIT\_A can be diode or'd to the INT line in such a way that a T\_CRIT\_A event activates the INT line, but an INT event does not activate the T\_CRIT\_A line. This may be useful in the event that it is desirable to notify both the processor and separate T\_CRIT\_A shutdown circuitry of a critical temperature alarm at the same time (maybe the processor is still working and can coordinate a graceful shutdown with the separate shutdown circuit).

To implement ACPI compatible sensing it is necessary to sense whenever the temperature goes outside the window, issue an interrupt, service the interrupt, and reprogram the window according to the desired granularity of the temperature scale. The reprogrammed window will now have the current temperature inside it, ready to issue an interrupt whenever the temperature deviates from the current window.

To understand this graph, assume that at the left hand side the system is at some nominal temperature. For the 1st event temperature rises above the upper window limit,  $T_{HIGH}$ , causing INT to go active. The system responds to the interrupt by querying the LM77's status bits and determines that  $T_{HIGH}$  was exceeded, indicating that temperature is rising. The system then reprograms the temperature limits to a value higher by an amount equal to the desired granularity. Note that in Event Interrupt Mode, reprogramming the limits has caused a second, known, interrupt to be issued since temperature has been returned within the window. In Comparator Interrupt Mode, the LM77 simply stops issuing interrupts.

The 2nd event is another identical rise in temperature. The 3rd event is typical of a drop in temperature. This is one of the conditions that demonstrates the power of the LM77, as the user receives notification that a lower limit is exceeded in such a way that temperature is dropping.

The Critical Alarm Event activates the separate T\_CRIT\_A output. Typically, this would feed circuitry separate from the processor on the assumption that if the system reached this temperature, the processor might not be responding.

### 3.0 Application Hints (Continued)

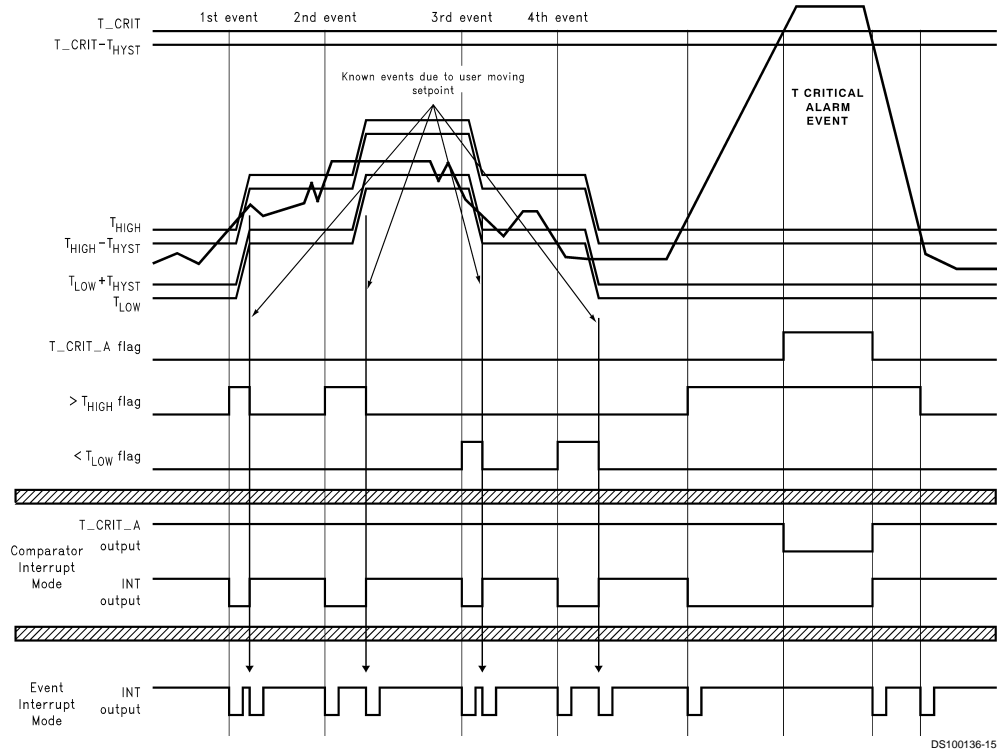

DS100136-15

**Note:** Event Interrupt mode is drawn as if the user is reading the part. If the user doesn't read, the outputs would go low and stay that way until the LM77 is read.

**FIGURE 7. Temperature Response Diagram for ACPI Implementation**

### 4.0 Typical Applications

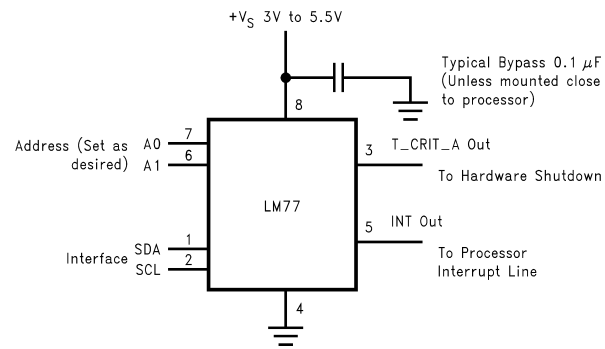

DS100136-16

**FIGURE 8. Typical Application**

### 4.0 Typical Applications (Continued)

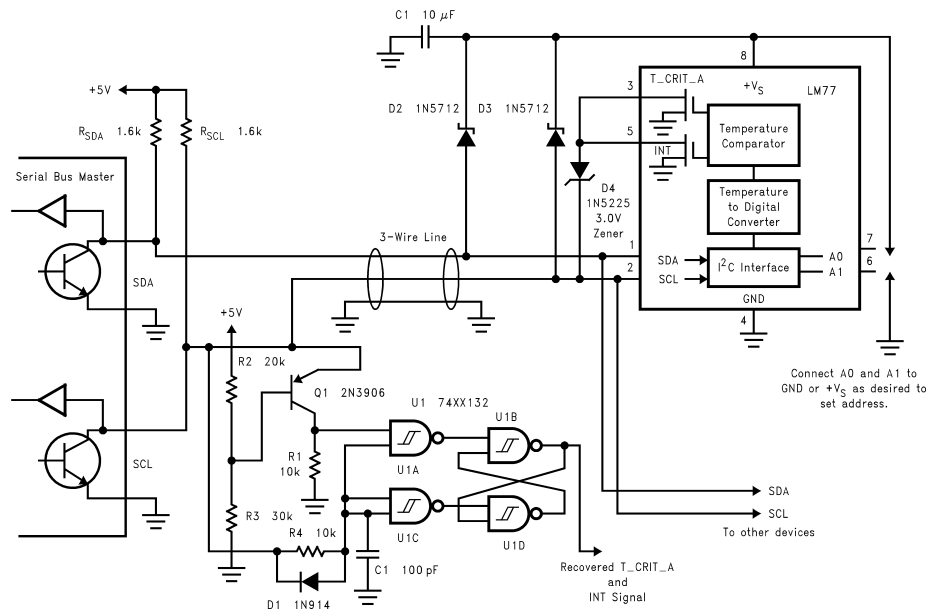

DS100136-17

FIGURE 9. Remote HVAC temperature sensor communicates via 3 wires, including thermostat signals.

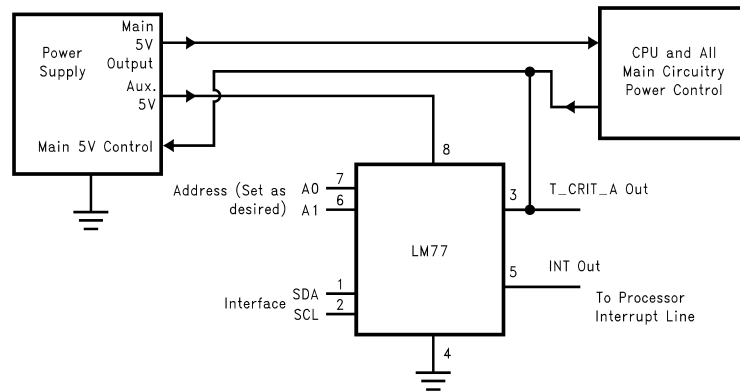

DS100136-19

FIGURE 10. ACPI Compatible Terminal Alarm Shutdown. By powering the LM77 from auxiliary output of the power supply, a non-functioning overheated computer can be powered down to preserve as much of the system as possible.

**Physical Dimensions** inches (millimeters) unless otherwise noted

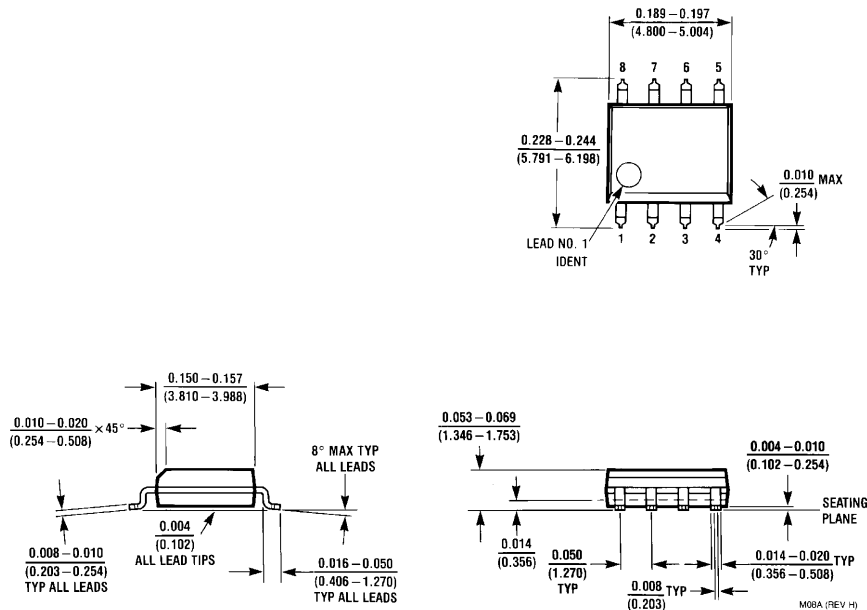

**8-Lead (0.150" Wide) Molded Small Outline Package (SOP), JEDEC Order Number LM77CIM-3, LM77CIMX-3, LM77CIM-5 or LM77CIMX-5 NS Package Number M08A**

**LIFE SUPPORT POLICY**

NATIONAL'S PRODUCTS ARE NOT AUTHORIZED FOR USE AS CRITICAL COMPONENTS IN LIFE SUPPORT DEVICES OR SYSTEMS WITHOUT THE EXPRESS WRITTEN APPROVAL OF THE PRESIDENT AND GENERAL COUNSEL OF NATIONAL SEMICONDUCTOR CORPORATION. As used herein:

1. Life support devices or systems are devices or systems which, (a) are intended for surgical implant into the body, or (b) support or sustain life, and whose failure to perform when properly used in accordance with instructions for use provided in the labeling, can be reasonably expected to result in a significant injury to the user.
2. A critical component is any component of a life support device or system whose failure to perform can be reasonably expected to cause the failure of the life support device or system, or to affect its safety or effectiveness.

**National Semiconductor Corporation**  
Americas  
Tel: 1-800-272-9959  
Fax: 1-800-737-7018  
Email: support@nsc.com  
[www.national.com](http://www.national.com)

**National Semiconductor Europe**  
Fax: +49 (0) 1 80-530 85 86  
Email: europe.support@nsc.com  
Deutsch Tel: +49 (0) 1 80-530 85 85  
English Tel: +49 (0) 1 80-532 78 32  
Français Tel: +49 (0) 1 80-532 93 58  
Italiano Tel: +49 (0) 1 80-534 16 80

**National Semiconductor Asia Pacific Customer Response Group**  
Tel: 65-2544466  
Fax: 65-2504466  
Email: sea.support@nsc.com

**National Semiconductor Japan Ltd.**  
Tel: 81-3-5639-7560  
Fax: 81-3-5639-7507

National does not assume any responsibility for use of any circuitry described, no circuit patent licenses are implied and National reserves the right at any time without notice to change said circuitry and specifications.

SUNSTAR商斯达实业集团是集研发、生产、工程、销售、代理经销、技术咨询、信息服务等为一体的高科技企业，是专业高科技电子产品生产厂家，是具有10多年历史的专业电子元器件供应商，是中国最早和最大的仓储式连锁规模经营大型综合电子零部件代理分销商之一，是一家专业代理和分销世界各大品牌IC芯片和电子元器件的连锁经营综合性国际公司。在香港、北京、深圳、上海、西安、成都等全国主要电子市场设有直属分公司和产品展示展销窗口门市部专卖店及代理分销商，已在全国范围内建成强大统一的供货和代理分销网络。我们专业代理经销、开发生产电子元器件、集成电路、传感器、微波光电元器件、工控机/DOC/DOM电子盘、专用电路、单片机开发、MCU/DSP/ARM/FPGA软件硬件、二极管、三极管、模块等，是您可靠的一站式现货配套供应商、方案提供商、部件功能模块开发配套商。专业以现代信息产业（计算机、通讯及传感器）三大支柱之一的传感器为主营业务，专业经营各类传感器的代理、销售生产、网络信息、科技图书资料及配套产品设计、工程开发。我们的专业网站——中国传感器科技信息网（全球传感器数据库）[www.SENSOR-IC.COM](http://www.SENSOR-IC.COM) 服务于全球高科技生产商及贸易商，为企业科技产品开发提供技术交流平台。欢迎各厂商互通有无、交换信息、交换链接、发布寻求代理信息。欢迎国外高科技传感器、变送器、执行器、自动控制产品厂商介绍产品到中国，共同开拓市场。本网站是关于各种传感器-变送器-仪器仪表及工业自动化大型专业网站，深入到工业控制、系统工程计 测量、自动化、安防报警、消费电子等众多领域，把最新的传感器-变送器-仪器仪表买卖信息，最新技术供求，最新采购商，行业动态，发展方向，最新的技术应用和市场资讯及时的传递给广大科技开发、科学研究、产品设计人员。本网站已成功为石油、化工、电力、医药、生物、航空、航天、国防、能源、冶金、电子、工业、农业、交通、汽车、矿山、煤炭、纺织、信息、通信、IT、安防、环保、印刷、科研、气象、仪器仪表等领域从事科学研究、产品设计、开发、生产制造的科技人员、管理人员、和采购人员提供满意服务。我们公司专业生产、代理、经销、销售各种传感器、变送器、敏感元器件、开关、执行器、仪器仪表、自动化控制系统：专门从事设计、生产、销售各种传感器、变送器、各种测控仪表、热工仪表、现场控制器、计算机控制系统、数据采集系统、各类环境监控系统、专用控制系统应用软件以及嵌入式系统开发及应用等工作。如热敏电阻、压敏电阻、温度传感器、温度变送器、湿度传感器、湿度变送器、气体传感器、气体变送器、压力传感器、压力变送、称重传感器、物（液）位传感器、物（液）位变送器、流量传感器、流量变送器、电流（压）传感器、溶氧传感器、霍尔传感器、图像传感器、超声波传感器、位移传感器、速度传感器、加速度传感器、扭距传感器、红外传感器、紫外传感器、火焰传感器、激光传感器、振动传感器、轴角传感器、光电传感器、接近传感器、干簧管传感器、继电器传感器、微型电泵、磁敏（阻）传感器、压力开关、接近开关、光电开关、色标传感器、光纤传感器、齿轮测速传感器、时间继电器、计数器、计米器、温控仪、固态继电器、调压模块、电磁铁、电压表、电流表等特殊传感器。同时承接传感器应用电路、产品设计和自动化工程项目。

更多产品请看本公司产品专用销售网站：

商斯达中国传感器科技信息网：<http://www.sensor-ic.com/>

商斯达工控安防网：<http://www.pc-ps.net/>

商斯达电子元器件网：<http://www.sunstare.com/>

商斯达微波光电产品网：[HTTP://www.rfoe.net/](http://www.rfoe.net/)

商斯达消费电子产品网：<http://www.icasic.com/>

商斯达军工产品网：<http://www.junpinic.com/>

商斯达实业科技产品网：<http://www.sunstars.cn/> 传感器销售热线：

地址：深圳市福田区福华路福庆街鸿图大厦1602室

电话：0755-83607652 83376489 83376549 83370250 83370251 82500323

传真：0755-83376182 (0) 13902971329 MSN: [SUNS888@hotmail.com](mailto:SUNS888@hotmail.com)

邮编：518033 E-mail: [szss20@163.com](mailto:szss20@163.com) QQ: 195847376

深圳赛格展销部：深圳华强北路赛格电子市场2583号 电话：0755-83665529 25059422

技术支持：0755-83394033 13501568376

欢迎索取免费详细资料、设计指南和光盘；产品凡多，未能尽录，欢迎来电查询。

北京分公司：北京海淀区知春路132号中发电子大厦3097号

TEL: 010-81159046 82615020 13501189838 FAX: 010-62543996

上海分公司：上海市北京东路668号上海赛格电子市场D125号

TEL: 021-28311762 56703037 13701955389 FAX: 021-56703037

西安分公司：西安高新开发区20所(中国电子科技集团导航技术研究所)

西安劳动南路88号电子商城二楼D23号

TEL: 029-81022619 13072977981 FAX: 029-88789382