



# Cold-Junction-Compensated K-Thermocouple-to-Digital Converter (0°C to +1024°C)

MAX6675

## General Description

The MAX6675 performs cold-junction compensation and digitizes the signal from a type-K thermocouple. The data is output in a 12-bit resolution, SPI™-compatible, read-only format.

This converter resolves temperatures to 0.25°C, allows readings as high as +1024°C, and exhibits thermocouple accuracy of 8LSBs for temperatures ranging from 0°C to +700°C.

The MAX6675 is available in a small, 8-pin SO package.

## Features

- ◆ Cold-Junction Compensation
- ◆ Simple SPI-Compatible Serial Interface
- ◆ 12-Bit, 0.25°C Resolution
- ◆ Open Thermocouple Detection

## Ordering Information

PART	TEMP. RANGE	PIN-PACKAGE
MAX6675ISA	-20°C to +85°C	8 SO

## Applications

Industrial  
Appliances  
HVAC  
Automotive

## Pin Configuration

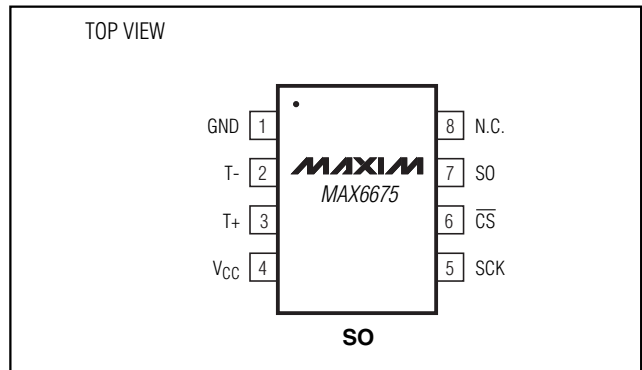

SPI is a trademark of Motorola, Inc.

## Typical Application Circuit

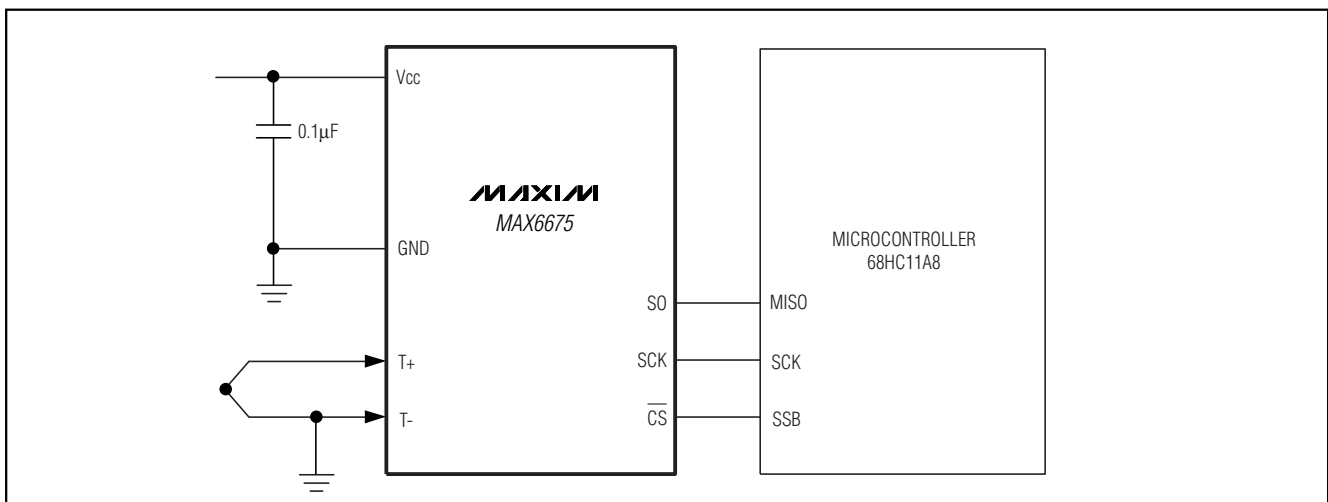

# Cold-Junction-Compensated K-Thermocouple-to-Digital Converter (0°C to +1024°C)

MAX6675

## ABSOLUTE MAXIMUM RATINGS

Supply Voltage (V<sub>CC</sub> to GND) ..... -0.3V to +6V  
 SO, SCK,  $\overline{CS}$ , T-, T+ to GND ..... -0.3V to V<sub>CC</sub> + 0.3V  
 SO Current ..... 50mA  
 ESD Protection (Human Body Model) ..... ±2000V  
 Continuous Power Dissipation (T<sub>A</sub> = +70°C)  
 8-Pin SO (derate 5.88mW/°C above +70°C) ..... 471mW  
 Operating Temperature Range ..... -20°C to +85°C

Storage Temperature Range ..... -65°C to +150°C  
 Junction Temperature ..... +150°C  
 SO Package  
 Vapor Phase (60s) ..... +215°C  
 Infrared (15s) ..... +220°C  
 Lead Temperature (soldering, 10s) ..... +300°C

Stresses beyond those listed under "Absolute Maximum Ratings" may cause permanent damage to the device. These are stress ratings only, and functional operation of the device at these or any other conditions beyond those indicated in the operational sections of the specifications is not implied. Exposure to absolute maximum rating conditions for extended periods may affect device reliability.

## ELECTRICAL CHARACTERISTICS

(V<sub>CC</sub> = +3.0V to +5.5V, T<sub>A</sub> = -20°C to +85°C, unless otherwise noted. Typical values specified at +25°C.) (Note 1)

PARAMETER	SYMBOL	CONDITIONS	MIN	TYP	MAX	UNITS	
Temperature Error		T <sub>THERMOCOUPLE</sub> = +700°C, T <sub>A</sub> = +25°C (Note 2)	V <sub>CC</sub> = +3.3V	-5		+5	LSB
			V <sub>CC</sub> = +5V	-6		+6	
		T <sub>THERMOCOUPLE</sub> = 0°C to +700°C, T <sub>A</sub> = +25°C (Note 2)	V <sub>CC</sub> = +3.3V	-8		+8	
			V <sub>CC</sub> = +5V	-9		+9	
		T <sub>THERMOCOUPLE</sub> = +700°C to +1000°C, T <sub>A</sub> = +25°C (Note 2)	V <sub>CC</sub> = +3.3V	-17		+17	
			V <sub>CC</sub> = +5V	-19		+19	
Thermocouple Conversion Constant				10.25		μV/LSB	
Cold-Junction Compensation		T <sub>A</sub> = -20°C to +85°C (Note 2)	V <sub>CC</sub> = +3.3V	-3.0		+3.0	°C
			V <sub>CC</sub> = +5V	-3.0		+3.0	
Resolution				0.25		°C	
Thermocouple Input Impedance				60		kΩ	
Supply Voltage	V <sub>CC</sub>		3.0		5.5	V	
Supply Current	I <sub>CC</sub>			0.7	1.5	mA	
Power-On Reset Threshold		V <sub>CC</sub> rising	1	2	2.5	V	
Power-On Reset Hysteresis				50		mV	
Conversion Time		(Note 2)		0.17	0.22	s	
<b>SERIAL INTERFACE</b>							
Input Low Voltage	V <sub>IL</sub>				0.3 x V <sub>CC</sub>	V	
Input High Voltage	V <sub>IH</sub>			0.7 x V <sub>CC</sub>		V	
Input Leakage Current	I <sub>LEAK</sub>	V <sub>IN</sub> = GND or V <sub>CC</sub>			±5	μA	
Input Capacitance	C <sub>IN</sub>			5		pF	

# Cold-Junction-Compensated K-Thermocouple-to-Digital Converter (0°C to +1024°C)

MAX6675

## ELECTRICAL CHARACTERISTICS (continued)

(V<sub>CC</sub> = +3.0V to +5.5V, T<sub>A</sub> = -20°C to +85°C, unless otherwise noted. Typical values specified at +25°C.) (Note 1)

PARAMETER	SYMBOL	CONDITIONS	MIN	TYP	MAX	UNITS
Output High Voltage	V <sub>OH</sub>	I <sub>SOURCE</sub> = 1.6mA	V <sub>CC</sub> - 0.4			V
Output Low Voltage	V <sub>OL</sub>	I <sub>SINK</sub> = 1.6mA			0.4	V
<b>TIMING</b>						
Serial Clock Frequency	f <sub>SCL</sub>				4.3	MHz
SCK Pulse High Width	t <sub>CH</sub>		100			ns
SCK Pulse Low Width	t <sub>CL</sub>		100			ns
CSB Fall to SCK Rise	t <sub>CSS</sub>	C <sub>L</sub> = 10pF	100			ns
CSB Fall to Output Enable	t <sub>DV</sub>	C <sub>L</sub> = 10pF			100	ns
CSB Rise to Output Disable	t <sub>TR</sub>	C <sub>L</sub> = 10pF			100	ns
SCK Fall to Output Data Valid	t <sub>DO</sub>	C <sub>L</sub> = 10pF			100	ns

**Note 1:** All specifications are 100% tested at T<sub>A</sub> = +25°C. Specification limits over temperature (T<sub>A</sub> = T<sub>MIN</sub> to T<sub>MAX</sub>) are guaranteed by design and characterization, not production tested.

**Note 2:** Guaranteed by design. Not production tested.

## Typical Operating Characteristics

(V<sub>CC</sub> = +3.3V, T<sub>A</sub> = +25°C, unless otherwise noted.)

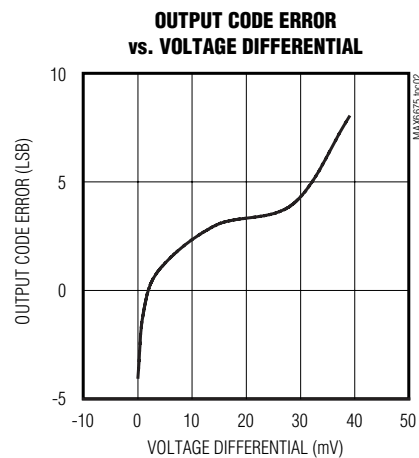
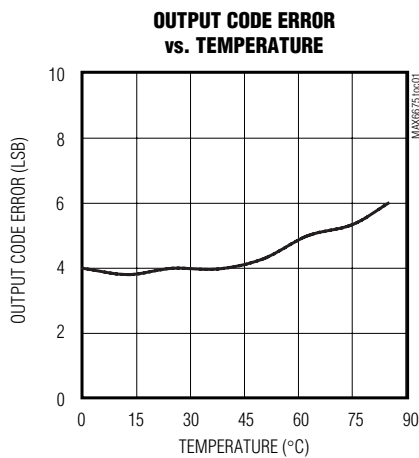

# Cold-Junction-Compensated K-Thermocouple-to-Digital Converter (0°C to +1024°C)

## Pin Description

PIN	NAME	FUNCTION
1	GND	Ground
2	T-	Iron Lead of Type-K Thermocouple. Should be connected to ground externally.
3	T+	Constantan Lead of Type-K Thermocouple
4	V <sub>CC</sub>	Positive Supply. Bypass with a 0.1μF capacitor to GND.
5	SCK	Serial Clock Input
6	$\overline{CS}$	Chip Select. Set $\overline{CS}$ low to enable the serial interface.
7	SO	Serial Data Output
8	N.C.	No Connection

## Detailed Description

The MAX6675 is a sophisticated thermocouple-to-digital converter with a built-in 12-bit analog-to-digital converter (ADC). The MAX6675 also contains cold-junction compensation sensing and correction, a digital controller, an SPI-compatible interface, and associated control logic.

The MAX6675 is designed to work in conjunction with an external microcontroller (μC) or other intelligence in thermostatic, process-control, or monitoring applications. The μC is typically a power-management or keyboard controller, generating SPI serial commands by “bit-banging” general-purpose input-output (GPIO) pins or through a dedicated SPI interface block.

### Temperature Conversion

The MAX6675 includes signal-conditioning hardware to convert the thermocouple's signal into a voltage compatible with the input channels of the ADC. The T+ and T- inputs connect to internal circuitry that reduces the introduction of noise errors from the thermocouple wires.

Before converting the thermoelectric voltages into equivalent temperature values, it is necessary to compensate for the difference between the thermocouple cold-junction side (MAX6675 ambient temperature) and a 0°C virtual reference. For a type-K thermocouple, the voltage changes by 41μV/°C, which approximates the

thermocouple characteristic with the following linear equation:

$$V_{OUT} = (41\mu V / ^\circ C) \times (T_R - T_{AMB})$$

Where:

V<sub>OUT</sub> is the thermocouple output voltage (μV).

T<sub>R</sub> is the temperature of the remote point (°C).

T<sub>AMB</sub> is the ambient temperature (°C).

### Cold-Junction Compensation

The function of the thermocouple is to sense a difference in temperature between two ends. The thermocouple's hot junction can be read from 0°C to +1023.75°C. The cold end (ambient temperature of the board on which the MAX6675 is mounted) can only range from -20°C to +85°C. While the temperature at the cold end fluctuates, the MAX6675 continues to accurately sense the temperature difference at the opposite end.

The MAX6675 senses and corrects for the changes in the ambient temperature with cold-junction compensation. The device converts the ambient temperature reading into a voltage using a temperature-sensing diode. To make the actual thermocouple temperature measurement, the MAX6675 measures the voltage from the thermocouple's output and from the sensing diode. The device's internal circuitry passes the diode's voltage (sensing ambient temperature) and thermocouple voltage (sensing remote temperature minus ambient temperature) to the conversion function stored in the ADC to calculate the thermocouple's hot-junction temperature.

Optimal performance from the MAX6675 is achieved when the thermocouple cold junction and the device are at the same temperature. Avoid placing heat-generating devices or components near the MAX6675 because this may produce cold-junction-related errors.

### Digitization

The ADC adds the cold-junction diode measurement with the amplified thermocouple voltage and reads out the 12-bit sequence onto the SO pin. A sequence of all zeros means the thermocouple reading is 0°C. A sequence of all ones means the thermocouple reading is +1023.75°C.

# Cold-Junction-Compensated K-Thermocouple-to-Digital Converter (0°C to +1024°C)

MAX6675

## Applications Information

### Serial Interface

The *Typical Application Circuit* shows the MAX6675 interfaced with a microcontroller. In this example, the MAX6675 processes the reading from the thermocouple and transmits the data through a serial interface. Force  $\overline{CS}$  low and apply a clock signal at SCK to read the results at SO. Forcing  $\overline{CS}$  low immediately stops any conversion process. Initiate a new conversion process by forcing  $\overline{CS}$  high.

Force  $\overline{CS}$  low to output the first bit on the SO pin. A complete serial interface read requires 16 clock cycles. Read the 16 output bits on the falling edge of the clock. The first bit, D15, is a dummy sign bit and is always zero. Bits D14–D3 contain the converted temperature in the order of MSB to LSB. Bit D2 is normally low and goes high when the thermocouple input is open. D1 is low to provide a device ID for the MAX6675 and bit D0 is three-state.

Figure 1a is the serial interface protocol and Figure 1b shows the serial interface timing. Figure 2 is the SO output.

### Open Thermocouple

Bit D2 is normally low and goes high if the thermocouple input is open. The open thermocouple detection circuit is implemented completely into the MAX6675. In order to allow the operation of the open thermocouple detector, T- must be grounded. Make the ground connection as close to the GND pin as possible.

### Noise Considerations

The accuracy of the MAX6675 is susceptible to power-supply coupled noise. The effects of power-supply noise can be minimized by placing a 0.1 $\mu$ F ceramic bypass capacitor close to the supply pin of the device.

### Thermal Considerations

Self-heating degrades the temperature measurement accuracy of the MAX6675 in some applications. The magnitude of the temperature errors depends on the

thermal conductivity of the MAX6675 package, the mounting technique, and the effects of airflow. Use a large ground plane to improve the temperature measurement accuracy of the MAX6675.

The accuracy of a thermocouple system can also be improved by following these precautions:

- Use the largest wire possible that does not shunt heat away from the measurement area.
- If small wire is required, use it only in the region of the measurement and use extension wire for the region with no temperature gradient.
- Avoid mechanical stress and vibration, which could strain the wires.
- When using long thermocouple wires, use a twisted-pair extension wire.
- Avoid steep temperature gradients.
- Try to use the thermocouple wire well within its temperature rating.
- Use the proper sheathing material in hostile environments to protect the thermocouple wire.
- Use extension wire only at low temperatures and only in regions of small gradients.
- Keep an event log and a continuous record of thermocouple resistance.

### Reducing Effects of Pick-Up Noise

The input amplifier (A1) is a low-noise amplifier designed to enable high-precision input sensing. Keep the thermocouple and connecting wires away from electrical noise sources.

## Chip Information

TRANSISTOR COUNT: 6720

PROCESS: BiCMOS

MAX6675

# Cold-Junction-Compensated K-Thermocouple-to-Digital Converter (0°C to +1024°C)

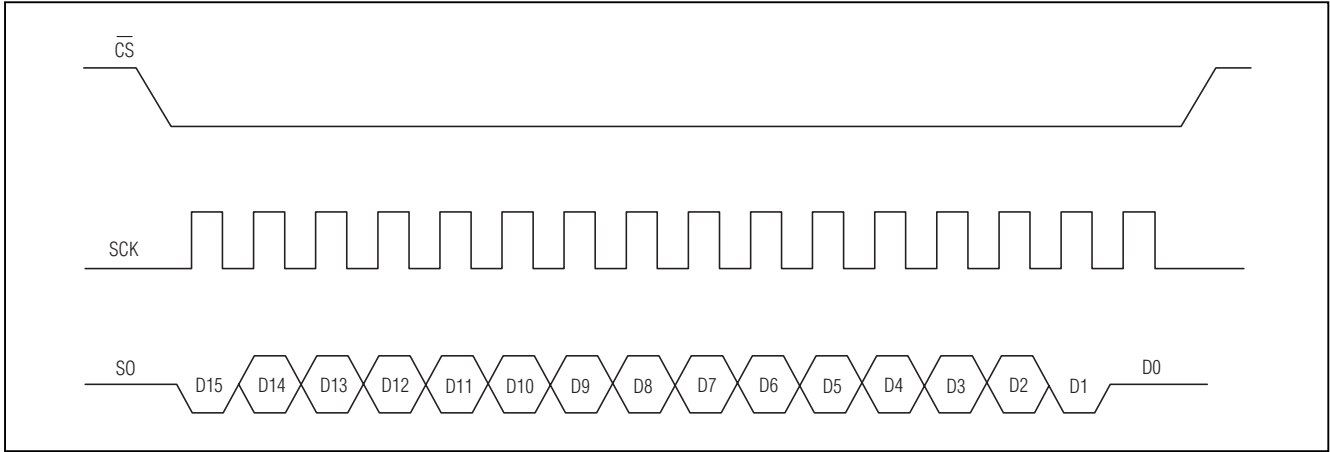

Figure 1a. Serial Interface Protocol

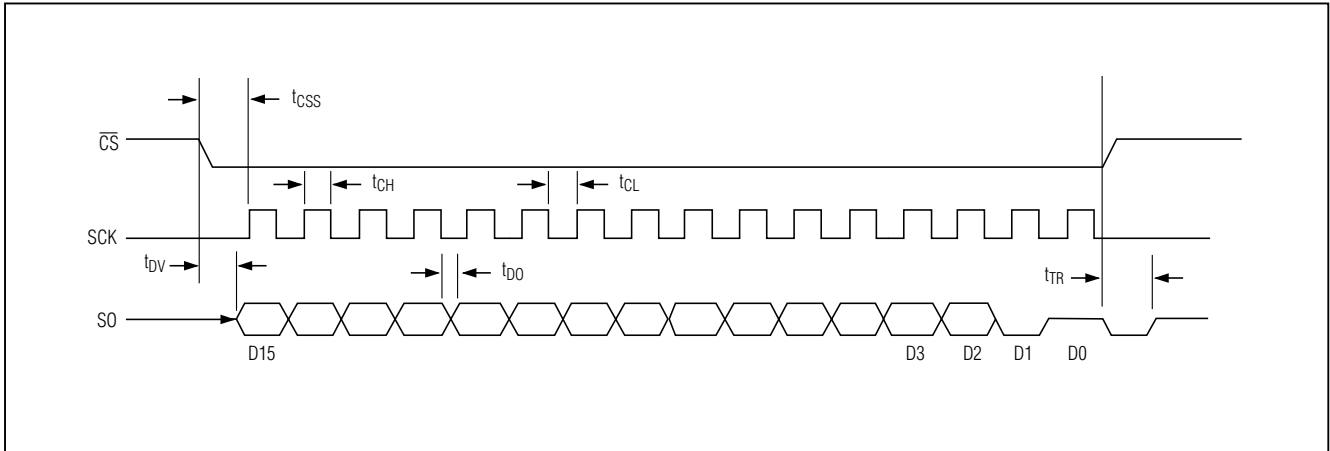

Figure 1b. Serial Interface Timing

BIT	DUMMY SIGN BIT	12-BIT TEMPERATURE READING											THERMOCOUPLE INPUT	DEVICE ID	STATE	
		14	13	12	11	10	9	8	7	6	5	4				3
Bit	15													2	1	0
	0	MSB											LSB		0	Three-state

Figure 2. SO Output

# Cold-Junction-Compensated K-Thermocouple-to-Digital Converter (0°C to +1024°C)

## Block Diagram

MAX6675

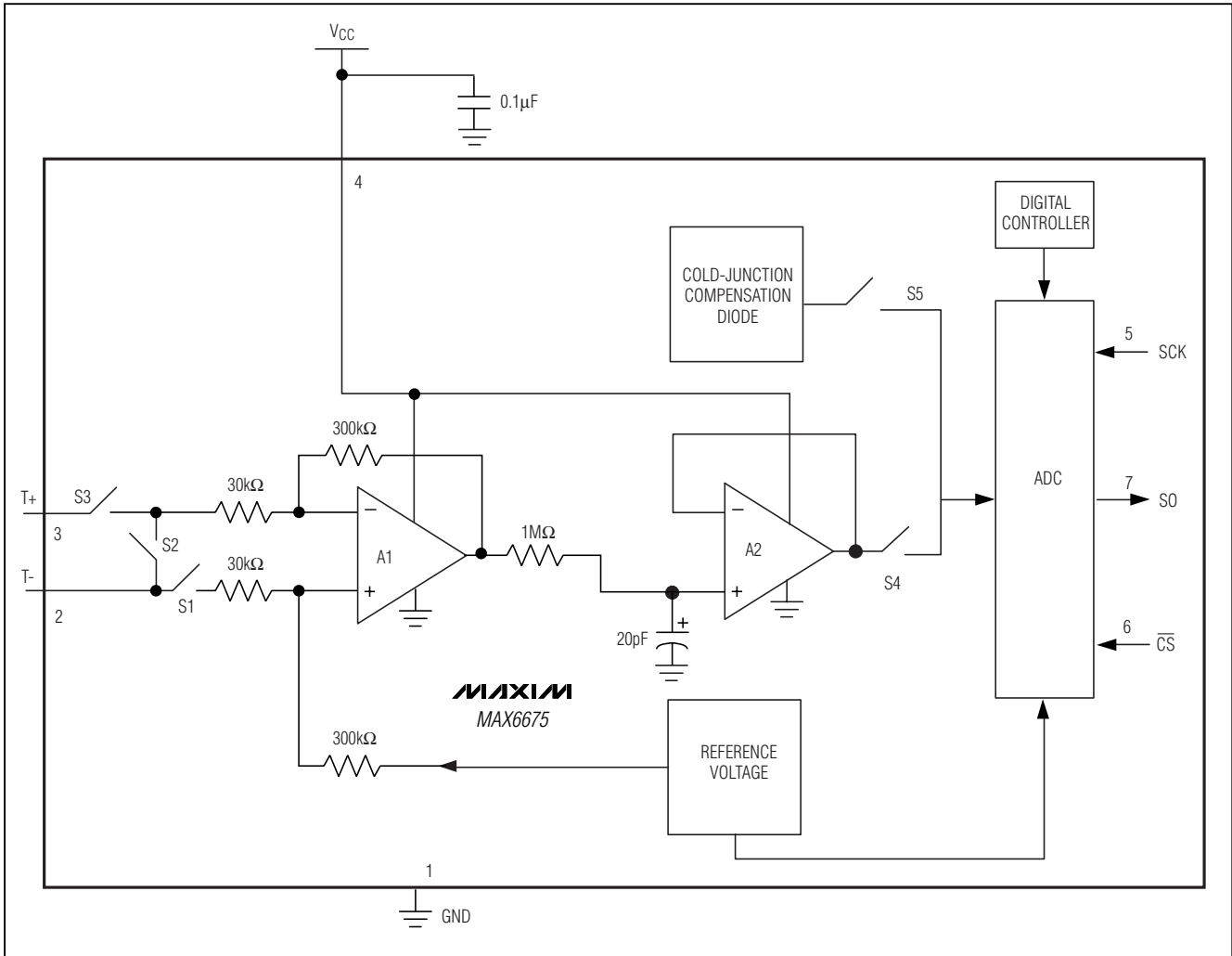

# Cold-Junction-Compensated K-Thermocouple-to-Digital Converter (0°C to +1024°C)

MAX6675

## Package Information

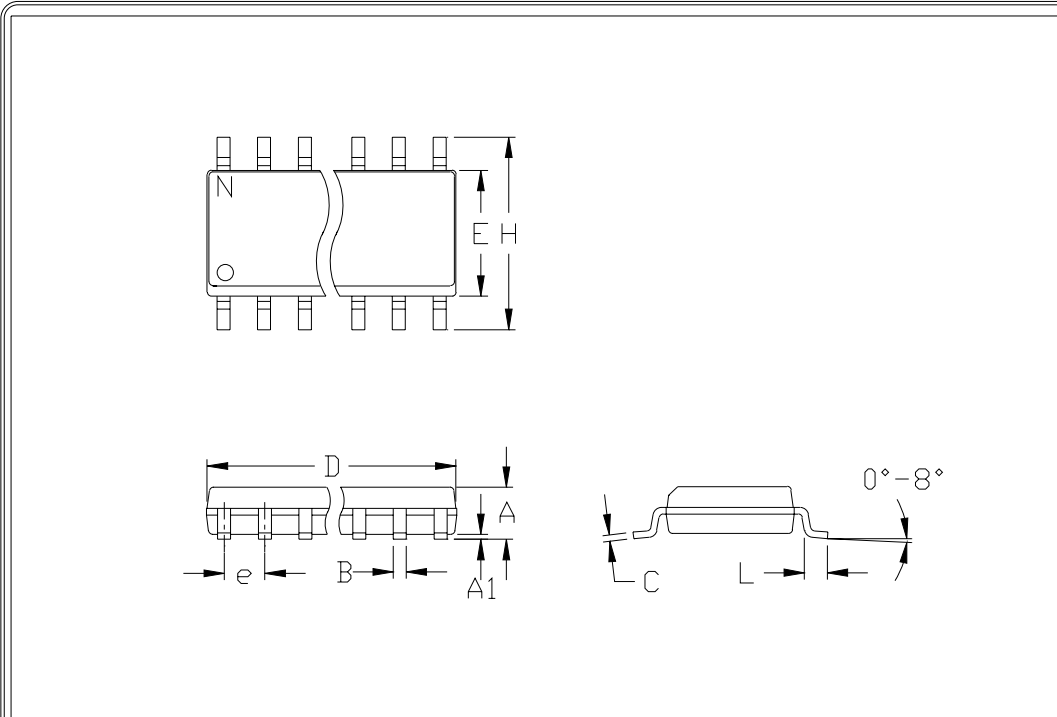

	INCHES		MILLIMETERS	
	MIN	MAX	MIN	MAX
A	0.053	0.069	1.35	1.75
A1	0.004	0.010	0.10	0.25
B	0.014	0.019	0.35	0.49
C	0.007	0.010	0.19	0.25
e	0.050		1.27	
E	0.150	0.157	3.80	4.00
H	0.228	0.244	5.80	6.20
h	0.010	0.020	0.25	0.50
L	0.016	0.050	0.40	1.27

	INCHES		MILLIMETERS		N	MS012
	MIN	MAX	MIN	MAX		
D	0.189	0.197	4.80	5.00	8	A
D	0.337	0.344	8.55	8.75	14	B
D	0.386	0.394	9.80	10.00	16	C

NOTES:

1. D&E DO NOT INCLUDE MOLD FLASH
2. MOLD FLASH OR PROTRUSIONS NOT TO EXCEED .15mm (.006")
3. LEADS TO BE COPLANAR WITHIN .102mm (.004")
4. CONTROLLING DIMENSION: MILLIMETER
5. MEETS JEDEC MS012-XX AS SHOWN IN ABOVE TABLE
6. N = NUMBER OF PINS

 <small>120 SAN GABRIEL DR. SUNNYVALE, CA 94086 FAX (408) 737 7194</small> <small>PROPRIETARY INFORMATION</small>	PACKAGE FAMILY OUTLINE: SOIC .150"		21-0041 A

Maxim cannot assume responsibility for use of any circuitry other than circuitry entirely embodied in a Maxim product. No circuit patent licenses are implied. Maxim reserves the right to change the circuitry and specifications without notice at any time.

8 \_\_\_\_\_ **Maxim Integrated Products, 120 San Gabriel Drive, Sunnyvale, CA 94086 408-737-7600**

© 2001 Maxim Integrated Products

Printed USA

**MAXIM** is a registered trademark of Maxim Integrated Products.



SUNSTAR商斯达实业集团是集研发、生产、工程、销售、代理经销、技术咨询、信息服务等为一体的高科技企业，是专业高科技电子产品生产厂家，是具有 10 多年历史的专业电子元器件供应商，是中国最早和最大的仓储式连锁规模经营大型综合电子零部件代理分销商之一，是一家专业代理和分销世界各大品牌 IC 芯片和电子元器件的连锁经营综合性国际公司。在香港、北京、深圳、上海、西安、成都等全国主要电子市场设有直属分公司和产品展示展销窗口门市部专卖店及代理分销商，已在全国范围内建成强大统一的供货和代理分销网络。我们专业代理经销、开发生产电子元器件、集成电路、传感器、微波光电元器件、工控机/DOC/DOM 电子盘、专用电路、单片机开发、MCU/DSP/ARM/FPGA 软件硬件、二极管、三极管、模块等，是您可靠的一站式现货配套供应商、方案提供商、部件功能模块开发配套商。专业以现代信息产业（计算机、通讯及传感器）三大支柱之一的传感器为主营业务，专业经营各类传感器的代理、销售生产、网络信息、科技图书资料及配套产品设计、工程开发。我们的专业网站——中国传感器科技信息网（全球传感器数据库）[www.SENSOR-IC.COM](http://www.SENSOR-IC.COM) 服务于全球高科技生产商及贸易商，为企业科技产品开发提供技术交流平台。欢迎各厂商互通有无、交换信息、交换链接、发布寻求代理信息。欢迎国外高科技传感器、变送器、执行器、自动控制产品厂商介绍产品到中国，共同开拓市场。本网站是关于各种传感器-变送器-仪器仪表及工业自动化大型专业网站，深入到工业控制、系统工程计 测量、自动化、安防报警、消费电子等众多领域，把最新的传感器-变送器-仪器仪表买卖信息，最新技术供求，最新采购商，行业动态，发展方向，最新的技术应用和市场资讯及时的传递给广大科技开发、科学研究、产品设计人员。本网站已成功为石油、化工、电力、医药、生物、航空、航天、国防、能源、冶金、电子、工业、农业、交通、汽车、矿山、煤炭、纺织、信息、通信、IT、安防、环保、印刷、科研、气象、仪器仪表等领域从事科学研究、产品设计、开发、生产制造的科技人员、管理人员、和采购人员提供满意服务。我们公司专业生产、代理、经销、销售各种传感器、变送器、敏感元器件、开关、执行器、仪器仪表、自动化控制系统：专业从事设计、生产、销售各种传感器、变送器、各种测控仪表、热工仪表、现场控制器、计算机控制系统、数据采集系统、各类环境监控系统、专用控制系统应用软件以及嵌入式系统开发及应用等工作。如热敏电阻、压敏电阻、温度传感器、温度变送器、湿度传感器、湿度变送器、气体传感器、气体变送器、压力传感器、压力变送、称重传感器、物（液）位传感器、物（液）位变送器、流量传感器、流量变送器、电流（压）传感器、溶氧传感器、霍尔传感器、图像传感器、超声波传感器、位移传感器、速度传感器、加速度传感器、扭距传感器、红外传感器、紫外传感器、火焰传感器、激光传感器、振动传感器、轴角传感器、光电传感器、接近传感器、干簧管传感器、继电器传感器、微型电泵、磁敏（阻）传感器、压力开关、接近开关、光电开关、色标传感器、光纤传感器、齿轮测速传感器、时间继电器、计数器、计米器、温控仪、固态继电器、调压模块、电磁铁、电压表、电流表等特殊传感器。同时承接传感器应用电路、产品设计和自动化工程项目。

更多产品请看本公司产品专用销售网站：

商斯达中国传感器科技信息网：<http://www.sensor-ic.com/>

商斯达工控安防网：<http://www.pc-ps.net/>

商斯达电子元器件网：<http://www.sunstare.com/>

商斯达微波光电产品网：[HTTP://www.rfoe.net/](http://www.rfoe.net/)

商斯达消费电子产品网：<http://www.icasic.com/>

商斯达军工产品网：<http://www.junpinic.com/>

商斯达实业科技产品网：<http://www.sunstars.cn/> 传感器销售热线：

地址：深圳市福田区福华路福庆街鸿图大厦 1602 室

电话：0755-83607652 83376489 83376549 83370250 83370251 82500323

传真：0755-83376182 (0) 13902971329 MSN: [SUNS888@hotmail.com](mailto:SUNS888@hotmail.com)

邮编：518033 E-mail: [szss20@163.com](mailto:szss20@163.com) QQ: 195847376

深圳赛格展销部：深圳华强北路赛格电子市场 2583 号 电话：0755-83665529 25059422

技术支持：0755-83394033 13501568376

欢迎索取免费详细资料、设计指南和光盘；产品凡多，未能尽录，欢迎来电查询。

北京分公司：北京海淀区知春路 132 号中发电子大厦 3097 号

TEL: 010-81159046 82615020 13501189838 FAX: 010-62543996

上海分公司：上海市北京东路 668 号上海赛格电子市场 D125 号

TEL: 021-28311762 56703037 13701955389 FAX: 021-56703037

西安分公司：西安高新开发区 20 所(中国电子科技集团导航技术研究所)

西安劳动南路 88 号电子商城二楼 D23 号

TEL: 029-81022619 13072977981 FAX:029-88789382