

Preliminary Specification

Allegro Current Sensor: ACS750

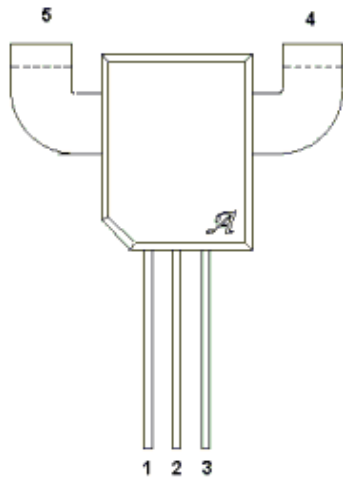

Pin 1: Vcc
 Pin 2: Gnd
 Pin 3: Output
 Pin 4: I_{p-}
 Pin 5: I_{p+}¹

ABSOLUTE MAXIMUM RATINGS

Over-Current	225 A ²
Supply Voltage, Vcc.....	16V
Output Voltage	16V
Output Current Source.....	3mA
Output Current Sink	10mA
Operating Temperature	-40°C to 150°C
Storage Temperature.....	170°C
Maximum junction temperature.....	165°C

The Allegro Current Sensor provides an economical and precise solution for current sensing in automotive and industrial systems, packaged for easy implementation. Typical applications include motor control, load management, switched mode power supplies and over-current fault protection.

The sensor consists of a precision linear Hall IC optimized to an internal magnetic circuit to increase device sensitivity. A combination of a precisely controlled self-aligning assembly process (patents pending) and the factory programmed precision of the linear Hall sensor result in high level performance and product uniformity.

The power lead frame used for current sensing (pins 4 and 5) is designed for extremely low power loss. The power leads are also electrically isolated from the sensor leads (pins 1 – 3). This isolation allows the Allegro Current Sensor to be used in applications requiring electrical isolation without the use of opto-isolators or other isolating feedback techniques.

Features and Benefits

- Monolithic Hall IC for High Reliability
- ACS750LCA-075: +/- 75A up to 150°C
- ACS750ECA-100: +/- 100A up to 85°C
- Ultra-low Power Loss: Resistance = 120uΩ
- No Trimming Required in the Application
- Factory Trimmed for Gain and Offset
- Linearity > 98.5%
- Very Low Thermal Drift of Offset Voltage
- 13kHz Bandwidth
- 5V Operation
- Ratiometric Output from Supply Voltage
- On-chip transient protection

Applications

- **Automotive Systems**
- **Industrial Systems**
- **Motor Control**
- **Process Control**
- **Servo Systems**
- **Power Conversion**
- **Battery Monitors**

¹ Primary current flowing I_{p+} to I_{p-} will generate output > Vcc/2

² 1 sec pulse, 10% duty cycle

Last updated September 16, 2002



115 Northeast Cutoff, Box 15036
 Worcester, Massachusetts 01615-0036 (508) 853-5000
 Copyright © 1993, 1995 Allegro Microsystems, Inc.

Preliminary Specification

Allegro Current Sensor: ACS750LCA

Operating Characteristics

Characteristic	Symbol	Test Conditions	Limits			
			Min.	Typ.	Max.	Units
ELECTRICAL CHARACTERISTICS						
Primary Sensed Current	I_P	-40°C to 150°C	-75		75	A
		-40°C to 85°C	-100		100	
Supply Voltage	V_{CC}		4.5	5.0	5.5	V
Supply Current	I_{CC}	$V_{CC} = 5.0V$, Output open		7	10	mA
Output Resistance	R_{out}	$I_{out} = 1.2 \text{ mA}$		1	2	Ω
Isolation Voltage ³	V_{ISO}	Between pins 1-3 and 4-5		2.5		kV
Propagation time	$t_{propagation}$	$I_P = \pm 50A$; $T = +25^\circ C$		4		μs
Response time	$t_{response}$	$I_P = \pm 50A$; $T = +25^\circ C$		27		μs
Rise time	$t_{rise \text{ time}}$	$I_P = \pm 50A$; $T = +25^\circ C$		26		μs
Frequency Bandwidth	f	-3dB		13		kHz
PERFORMANCE CHARACTERISTICS (Over -40°C to 150°C temperature range unless otherwise specified)						
Sensitivity	Sens	$I_P = \pm 75A$; $T = +25^\circ C$	18.75	19.75	20.75	mV/A
		$I_P = \pm 100A$; $T = +25^\circ C$	18.5	19.5	20.5	
Noise ⁴		Peak to peak; $T = +25^\circ C$ BW = 40kHz		10		mV
Non-linearity		$I_P = \pm 75A$, $T = -40^\circ C$ to $150^\circ C$		1.3	3.2	%
		$I_P = \pm 100A$, $T = -40^\circ C$ to $85^\circ C$		2.4	4.8	%
Quiescent Output Voltage ⁵	V_{OQ}	$I_P = 0 \text{ A}$; $T = +25^\circ C$	-5	$V_{CC}/2$	+5	mV
Thermal Drift of V_{OQ} ⁶	$\Delta V_{OQ}(T)$	$I_P = 0 \text{ A}$	-0.47	-0.12	+0.23	mV/°C
Thermal Drift of Sens	$\Delta \text{Sens}(T)$	$I_P = \pm 75A$; $T = -40^\circ C$ to $150^\circ C$	-0.06	0	+0.06	%/°C
		$I_P = \pm 100A$; $T = -40^\circ C$ to $85^\circ C$	-0.06	0	+0.08	
Magnetic Core Hysteresis ⁷	V_{OH}	After excursion to $\pm 225A$ $T = +25^\circ C$		± 0.3	± 0.4	A
0 Amp Accuracy Including offset	0 A	$T = +25^\circ C$		± 0.3	± 0.4	A
		$T = -40^\circ C$ to $85^\circ C$		± 0.75	± 1.8	A
		$T = -40^\circ C$ to $150^\circ C$		± 1.1	± 3.2	A
Total Accuracy ⁸	Full Scale	$I_P = \pm 75A$; $T = +25^\circ C$		± 1.0	± 2.3	%
		$I_P = \pm 100A$; $T = +25^\circ C$		± 2.0	± 3.5	%
		$I_P = \pm 75A$; $T = -40^\circ C$ to $150^\circ C$		± 2.4	± 7.8	%
		$I_P = \pm 100A$; $T = -40^\circ C$ to $85^\circ C$		± 4.9	± 11.9	%

³ R.M.S. voltage for AC isolation test, 60 Hz, 5 min. duration.

⁴ Refer to figure 5 for schematic of test circuit

⁵ Omitting magnetic hysteresis offset

⁶ V_{OQ} & Sensitivity gain drift referenced to 25°C

⁷ Refer to figure 6 for hysteresis temperature characterization

⁸ Please contact Allegro sales representative for competitive comparison

Last updated September 16, 2002



115 Northeast Cutoff, Box 15036
Worcester, Massachusetts 01615-0036 (508) 853-5000
Copyright © 1993, 1995 Allegro Microsystems, Inc.

Allegro Current Sensor: ACS750LCA

Definitions of accuracy characteristics

Sensitivity: The sensitivity is the change in sensor output to 1A change through the primary conductor. The sensitivity is the product of the magnetic circuit sensitivity (G/A) and the linear IC amplifier gain (mV/G). The linear IC amplifier gain is trimmed to optimize the sensitivity (mV/A) for the full-scale current of the device. Variation in the sensitivity is affected by the resolution of the Allegro linear IC sensitivity trim (~10uV/step) and thermal drift (expressed in %/C).

Noise: The noise is the product of the linear IC amplifier gain (mV/G) and the noise floor for the Allegro linear IC (~1Gauss). The noise floor is derived from the thermal and shot noise observed in Hall elements. Dividing the noise (mV) by the sensitivity (mV/A) provides the smallest current that the device is able to resolve.

Linearity: The linearity is the degree to which the voltage output from the sensor varies in direct proportion to the primary current through its full-scale amplitude. Linearity reveals the maximum deviation from the ideal transfer curve for this transducer. Non-linearity in the output can be attributed to the gain variation across temperature and saturation of the flux concentrator approaching the full scale current. The following equation is used to derive the linearity:

$$[1 - \frac{V_{out_full-scale\ Amps} - V_{out_0A}}{2 * (V_{out_1/2\ full-scale\ Amps} - V_{out_0A})}] * 100$$

Quiescent output voltage: The quiescent output voltage (V_{OQ}) is the output of the sensor when the primary current is zero. For a unipolar supply voltage, V_{OQ} nominally sits at $V_{CC}/2$. $V_{CC} = 5V$ translates into $V_{OQ} = 2.5V$. Variation in V_{OQ} can be attributed to the resolution of the Allegro linear IC quiescent voltage trim (~2.5mV), magnetic hysteresis, and thermal drift (expressed in %/C).

Magnetic hysteresis (offset): The magnetic offset is due to the residual magnetism (remanent field) that induces an offset in gauss. The magnetic offset error is highest when the magnetic circuit has been saturated, usually when the device has been subjected to a full scale or high current overload conditions. The magnetic offset is largely dependent on the material used as a flux concentrator. For most materials, the largest magnetic offset is observed at the lowest operating temperature.

Accuracy: The accuracy represents the maximum deviation of the actual output from its ideal value. This is also known as the total error. The accuracy is illustrated graphically in Figure #1. The accuracy is divided into four areas of particular interest defined below:

- **0 A @ 25°C:** Accuracy of sensing zero current flow at 25°C, without the effects of temperature.
- **0 A over temperature:** Accuracy of sensing zero current flow including temperature effects.
- **Full-scale current @ 25°C:** Accuracy of sensing the full-scale current at 25°C, without the effects of temperature.
- **Full-scale current over temperature:** Accuracy of sensing full-scale current flow including temperature effects.

Preliminary Specification

Allegro Current Sensor: ACS750LCA

Figure 1: Output Voltage vs. Current, illustrating sensor accuracy at 0A and full-scale current

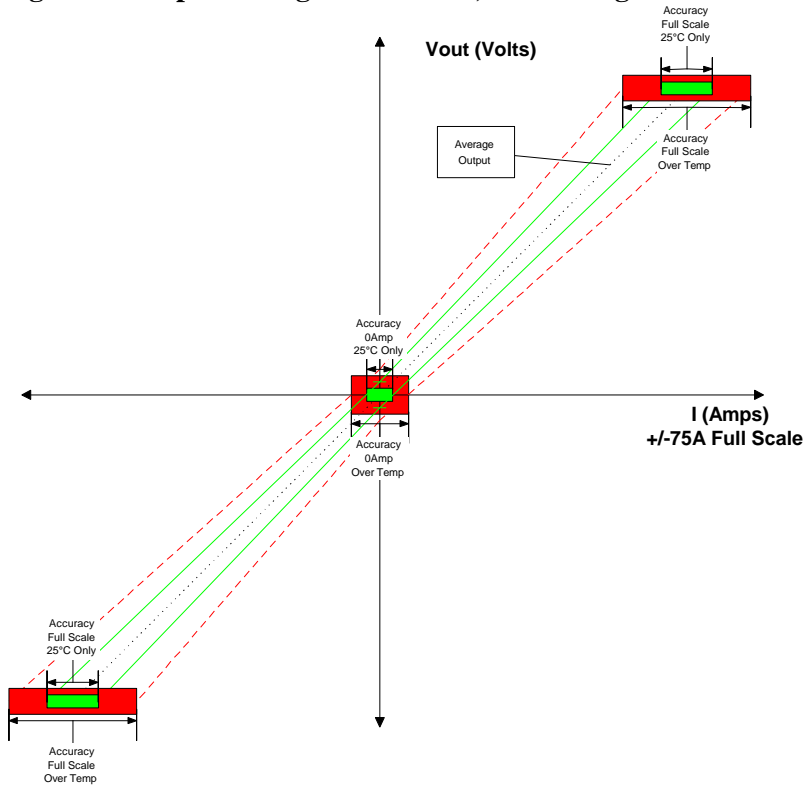
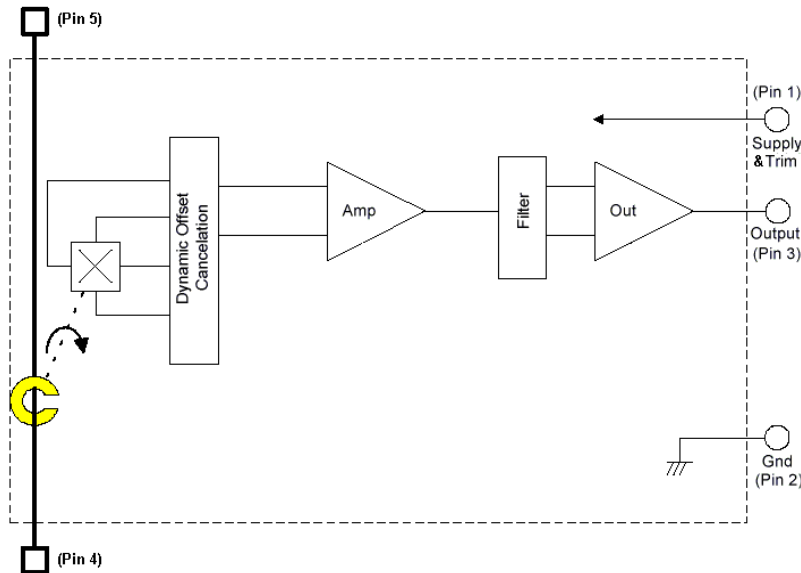

Figure 2: Block diagram of ACS750LCA-075 and linear Hall Effect IC functionality



Last updated September 16, 2002



115 Northeast Cutoff, Box 15036
 Worcester, Massachusetts 01615-0036 (508) 853-5000
 Copyright © 1993, 1995 Allegro Microsystems, Inc.

Preliminary Specification

Allegro Current Sensor: ACS750LCA

Figure 3: Primary current versus typical output voltage across temperature

I_{primary} vs V_{out}, ACS750LCA-075

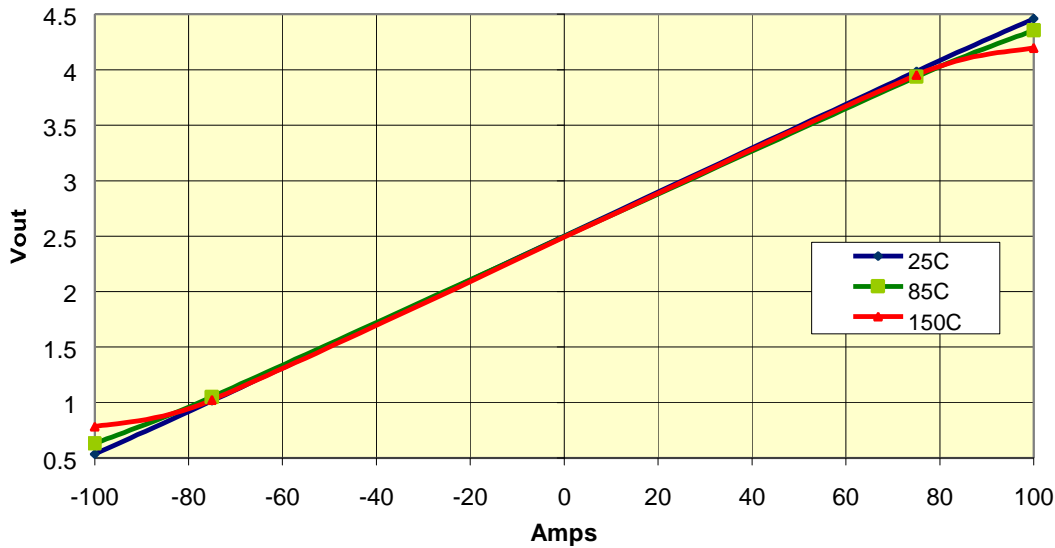
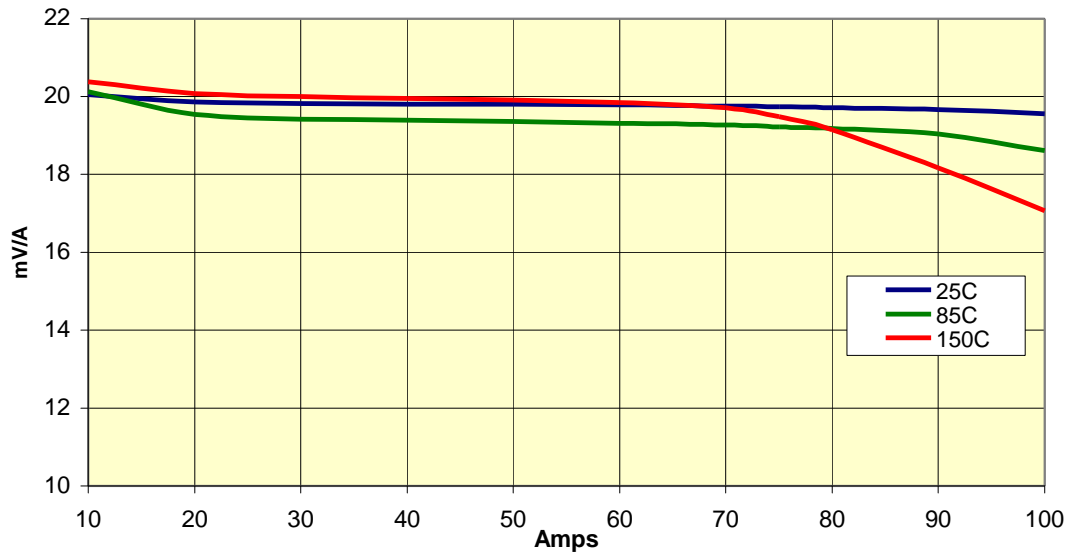

Figure 4: Primary current versus typical sensitivity across temperature

I_{primary} vs Sensitivity, ACS750LCA-075



Last updated September 16, 2002



115 Northeast Cutoff, Box 15036
 Worcester, Massachusetts 01615-0036 (508) 853-5000
 Copyright © 1993, 1995 Allegro Microsystems, Inc.

Preliminary Specification

Allegro Current Sensor: ACS750LCA

Figure 5a – Test circuit used to determine peak to peak & RMS noise in linear IC output

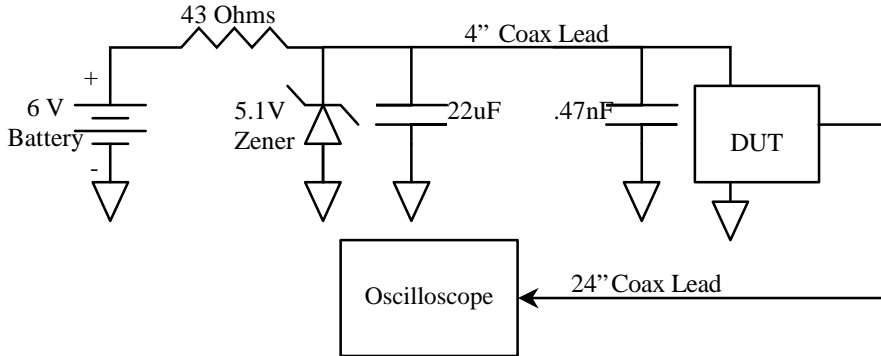
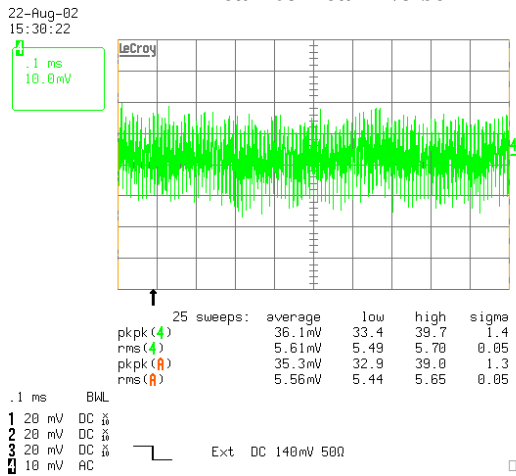

Figure 5b. Noise Analysis of Linear Hall Effect IC within ACS750LCA-075 Package

Peak to Peak Noise



Frequency Spectrum of Noise

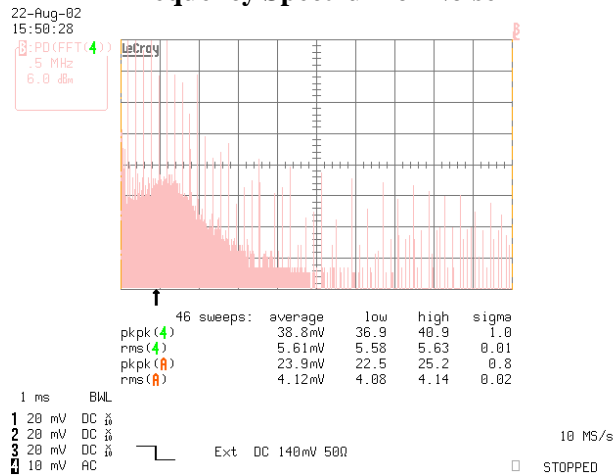

Figure 5c: Peak to Peak Noise, Applying Low Pass Filter to the ACS750LCA-075 Output

Low Pass Filter Break Frequency	Peak to Peak Noise
1.4MHz	34mV
400kHz	26mV
160kHz	19mV
80kHz	14mV
40kHz	10mV

Last updated September 16, 2002



115 Northeast Cutoff, Box 15036
 Worcester, Massachusetts 01615-0036 (508) 853-5000
 Copyright © 1993, 1995 Allegro Microsystems, Inc.

Preliminary Specification

Allegro Current Sensor: ACS750LCA

Figure 6: Peak to Peak Hysteresis Across Temperature (after excursion to +/-150A)

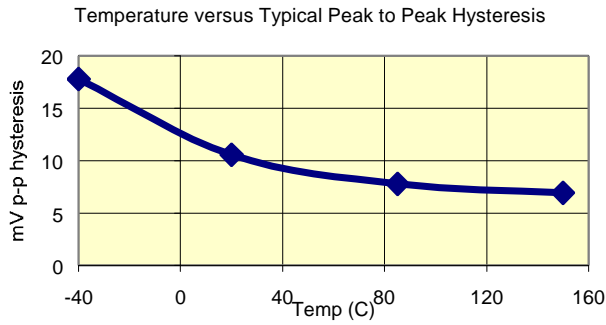

Figure 7: Rejection of Transient Voltage Signal on Iprimary, Typical Attenuation ~55dB

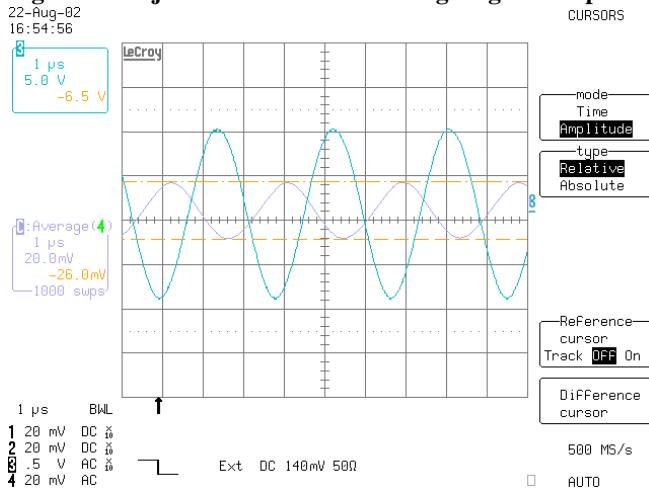
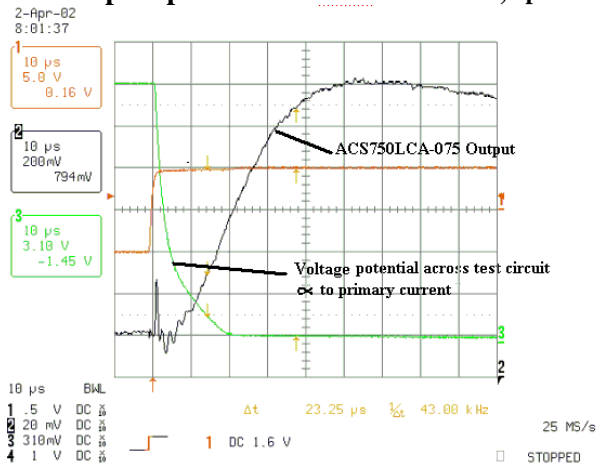

Figure 8: Step response of ACS750LCA-075, Iprimary = 50A



Last updated September 16, 2002



115 Northeast Cutoff, Box 15036
 Worcester, Massachusetts 01615-0036 (508) 853-5000
 Copyright © 1993, 1995 Allegro Microsystems, Inc.

Allegro Current Sensor: ACS750LCA

Definitions of dynamic response characteristics

Propagation delay: Propagation delay is the time that it takes for the sensor output to reflect a change in the primary current signal. Propagation delay is typically measured to be 3 to 5usec and is attributed to inductive loading within the linear IC package as well as the inductive loop formed by the primacy conductor geometry. Propagation delay can be considered as a fixed time offset and may be compensated.

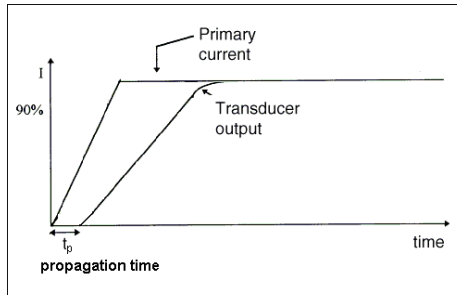

Response time: Response time is the time between when the primary current signal reaches 90% of its final value and when the sensor reaches 90% of its output corresponding to the applied current.

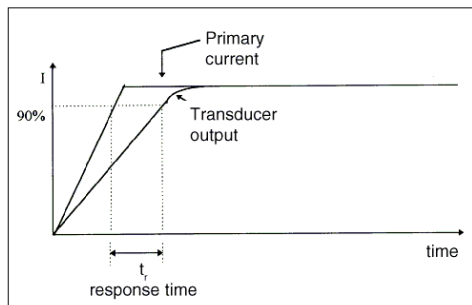

Rise time: Rise time is the time between the sensor output reaching 10 and 90% of its full scale value. The rise time to a step response is used to derive the bandwidth of the current sensor, in which $f(-3dB) = 0.35/tr$. Both rise time and response time are detrimentally affected by eddy current losses observed in the conductive IC ground plane and to varying degrees, in the ferrous flux concentrator within the current sensor package.

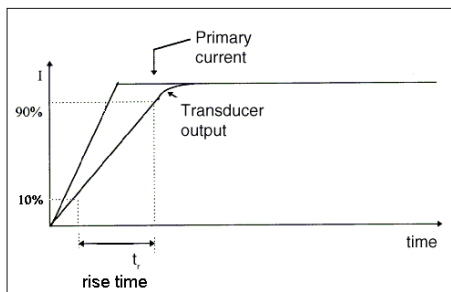

Last updated September 16, 2002



115 Northeast Cutoff, Box 15036
Worcester, Massachusetts 01615-0036 (508) 853-5000
Copyright © 1993, 1995 Allegro Microsystems, Inc.

Preliminary Specification

Allegro Current Sensor: ACS750LCA

Package thermal performance

	Symbol	Test Conditions	Limits		
			Typical	Max.	Units
Electrical resistance of primary conductor	R _{primary}	I _P = ±100A; +25°C	130	TBD	μΩ
Full-scale power dissipation	P _{primary}	I _P = ±100A; +25°C	1.5	TBD	W
Thermal resistance, Junction to Air	θ _{JA}	T _{ambient} = +25°C	9	TBD	°C/W

Figure 9: Thermal performance of current sensor, continuous current through primary conductor⁹

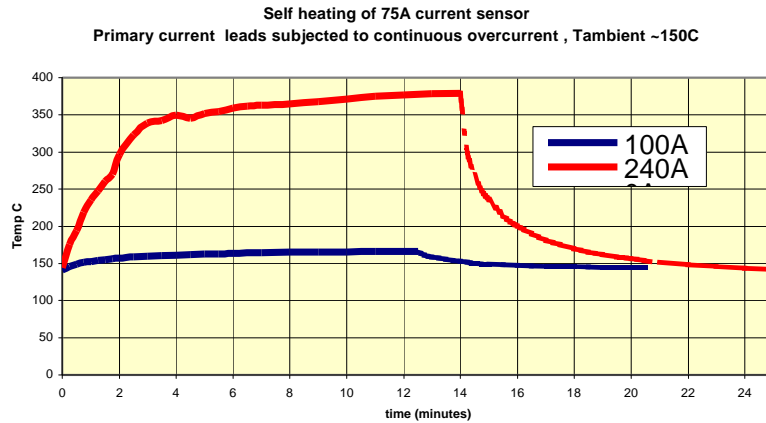
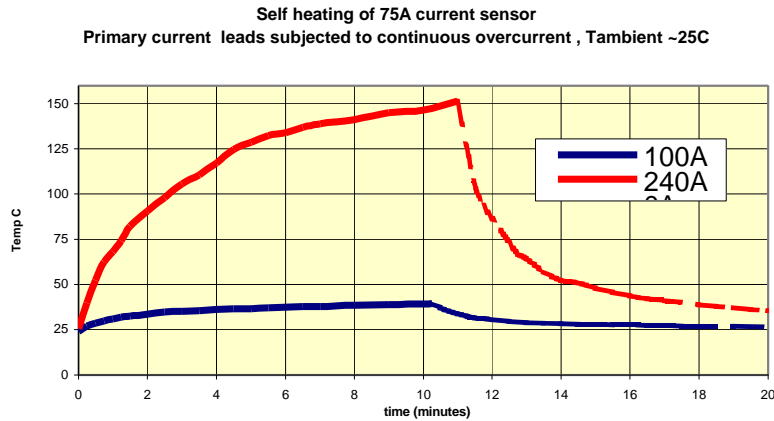

⁹ Over current peak operation is 225A peak, 1 second duration with 10% duty cycle



Preliminary Specification

Allegro Current Sensor: ACS750LCA

PACKAGE DRAWING

REVISIONS				
DCN	REV	DESCRIPTION	DATE	APPROVED
	A	updated model	9-20-02	

Notes:

1. Draft angle 10° unless otherwise specified
2. All edges can have 0.25mm radius max unless otherwise specified
3. Vertical lead trim or stamping burrs: 0.15mm max
4. Gate protrusion & parting line, Epin & body flash: 0.2mm max
5. Package top to bottom offset: 0.15mm max
6. Lead flash along edge or sides: 3mm max
7. Yolds & Imperfections: 0.5mm max dimension
8. There is reduced solder joint reliability at bands or where Copper is exposed due to trimming or forming of leads.
9. Tooling marks on the power leadframe and K package leads are normal due to the close molding tolerances to prevent excessive flash.

162 Pembroke Road
Concord, NH 03301
(603) 228-8533

UNLESS OTHERWISE SPECIFIED USE THE FOLLOWING	SIGNATURE	DATE	TITLE
DIMENSIONS PER ASME Y14.5M - 1992 INTERPRET DIM PER ASME Y14.5M - 1992	DRAWN CHECKED	R. ENGBR 6-17-02	Current Sensor - 100 Amp Preliminary Customer Drawing
TOLERANCES FRACTIONS: ± 0.2 DECIMALS: ± 0.25 DECIMALS: ± 0.1 ANGLES: °	ALL DIMENSIONS IN MILLIMETERS		TYP: Δ DRAWING NO: CS/A 100 cust SCALE: NONE SHEET 1 of 1
PROPERTY OF ALLEGRO MICROSYSTEMS, INC. USE AND/OR REPRODUCTION ONLY AS EXPRESSLY AUTHORIZED. TO BE RETURNED UPON DEMAND.			

Last updated September 16, 2002



115 Northeast Cutoff, Box 15036
Worcester, Massachusetts 01615-0036 (508) 853-5000
Copyright © 1993, 1995 Allegro MicroSystems, Inc.

Preliminary Specification

Allegro Current Sensor: ACS750LCA

This page is intentionally left blank.

Last updated September 16, 2002



115 Northeast Cutoff, Box 15036
Worcester, Massachusetts 01615-0036 (508) 853-5000
Copyright © 1993, 1995 Allegro MicroSystems, Inc.

11

SUNSTAR商斯达实业集团是集研发、生产、工程、销售、代理经销、技术咨询、信息服务等为一体的高科技企业，是专业高科技电子产品生产厂家，是具有 10 多年历史的专业电子元器件供应商，是中国最早和最大的仓储式连锁规模经营大型综合电子零部件代理分销商之一，是一家专业代理和分销世界各大品牌 IC 芯片和电子元器件的连锁经营综合性国际公司。在香港、北京、深圳、上海、西安、成都等全国主要电子市场设有直属分公司和产品展示展销窗口门市部专卖店及代理分销商，已在全国范围内建成强大统一的供货和代理分销网络。我们专业代理经销、开发生产电子元器件、集成电路、传感器、微波光电元器件、工控机/DOC/DOM 电子盘、专用电路、单片机开发、MCU/DSP/ARM/FPGA 软件硬件、二极管、三极管、模块等，是您可靠的一站式现货配套供应商、方案提供商、部件功能模块开发配套商。专业以现代信息产业（计算机、通讯及传感器）三大支柱之一的传感器为主营业务，专业经营各类传感器的代理、销售生产、网络信息、科技图书资料及配套产品设计、工程开发。我们的专业网站——中国传感器科技信息网（全球传感器数据库）www.SENSOR-IC.COM 服务于全球高科技生产商及贸易商，为企业科技产品开发提供技术交流平台。欢迎各厂商互通有无、交换信息、交换链接、发布寻求代理信息。欢迎国外高科技传感器、变送器、执行器、自动控制产品厂商介绍产品到中国，共同开拓市场。本网站是关于各种传感器-变送器-仪器仪表及工业自动化大型专业网站，深入到工业控制、系统工程计 测量、自动化、安防报警、消费电子等众多领域，把最新的传感器-变送器-仪器仪表买卖信息，最新技术供求，最新采购商，行业动态，发展方向，最新的技术应用和市场资讯及时的传递给广大科技开发、科学研究、产品设计人员。本网站已成功为石油、化工、电力、医药、生物、航空、航天、国防、能源、冶金、电子、工业、农业、交通、汽车、矿山、煤炭、纺织、信息、通信、IT、安防、环保、印刷、科研、气象、仪器仪表等领域从事科学研究、产品设计、开发、生产制造的科技人员、管理人员、和采购人员提供满意服务。我公司专业生产、代理、经销、销售各种传感器、变送器、敏感元器件、开关、执行器、仪器仪表、自动化控制系统：专业从事设计、生产、销售各种传感器、变送器、各种测控仪表、热工仪表、现场控制器、计算机控制系统、数据采集系统、各类环境监控系统、专用控制系统应用软件以及嵌入式系统开发及应用等工作。如热敏电阻、压敏电阻、温度传感器、温度变送器、湿度传感器、湿度变送器、气体传感器、气体变送器、压力传感器、压力变送、称重传感器、物（液）位传感器、物（液）位变送器、流量传感器、流量变送器、电流（压）传感器、溶氧传感器、霍尔传感器、图像传感器、超声波传感器、位移传感器、速度传感器、加速度传感器、扭距传感器、红外传感器、紫外传感器、火焰传感器、激光传感器、振动传感器、轴角传感器、光电传感器、接近传感器、干簧管传感器、继电器传感器、微型电泵、磁敏（阻）传感器、压力开关、接近开关、光电开关、色标传感器、光纤传感器、齿轮测速传感器、时间继电器、计数器、计米器、温控仪、固态继电器、调压模块、电磁铁、电压表、电流表等特殊传感器。同时承接传感器应用电路、产品设计和自动化工程项目。

更多产品请看本公司产品专用销售网站：

商斯达中国传感器科技信息网：<http://www.sensor-ic.com/>

商斯达工控安防网：<http://www.pc-ps.net/>

商斯达电子元器件网：<http://www.sunstare.com/>

商斯达微波光电产品网：[HTTP://www.rfoe.net/](http://www.rfoe.net/)

商斯达消费电子产品网：<http://www.icasic.com/>

商斯达军工产品网：<http://www.junpinic.com/>

商斯达实业科技产品网：<http://www.sunstars.cn/> 传感器销售热线：

地址：深圳市福田区福华路福庆街鸿图大厦 1602 室

电话：0755-83607652 83376489 83376549 83370250 83370251 82500323

传真：0755-83376182 (0) 13902971329 MSN: SUNS888@hotmail.com

邮编：518033 E-mail: szss20@163.com QQ: 195847376

深圳赛格展销部：深圳华强北路赛格电子市场 2583 号 电话：0755-83665529 25059422

技术支持：0755-83394033 13501568376

欢迎索取免费详细资料、设计指南和光盘；产品凡多，未能尽录，欢迎来电查询。

北京分公司：北京海淀区知春路 132 号中发电子大厦 3097 号

TEL: 010-81159046 82615020 13501189838 FAX: 010-62543996

上海分公司：上海市北京东路 668 号上海赛格电子市场 D125 号

TEL: 021-28311762 56703037 13701955389 FAX: 021-56703037

西安分公司：西安高新开发区 20 所(中国电子科技集团导航技术研究所)

西安劳动南路 88 号电子商城二楼 D23 号

TEL: 029-81022619 13072977981 FAX: 029-88789382