

HARLID™ Series, HARLID-362 Module

High Angular Resolution Laser Irradiance Detector

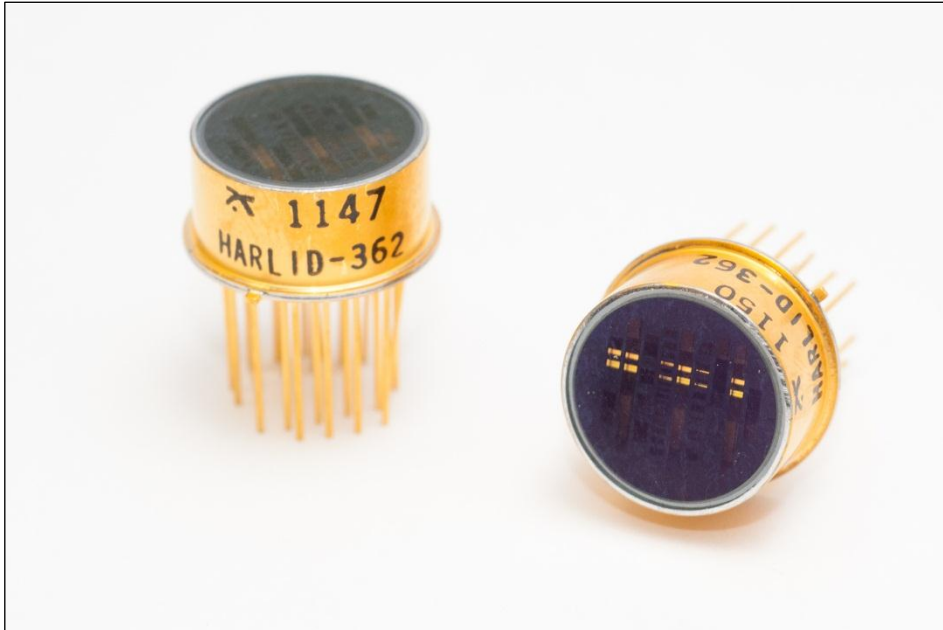

Excelitas' HARLID-362 Module detects and provides highly-precise AoA information from laser range finders, laser target designators and active E.O. systems for driving effective countermeasures.

Excelitas' HARLID™ (High Angular Resolution Laser Irradiance Detector) platform is designed for use in Laser Warning Receiver Systems to detect and provide precise angle-of-arrival (AoA) information from direct and indirect scattered light from laser range finders, target designators, and active laser Electro-Optic (E.O.) systems. The HARLID-362 Module makes use of 9-element Si and InGaAs detector arrays assembled in a sandwich configuration, in conjunction with light guides and a 6-bit digital Gray code mask which, through shadowing of the individual channels, encode the incident laser beam AoA into a digital pattern. Figure 1 illustrates the HARLID's Principle of Operation. For simplicity, the figure shows only four channels (bits) but does not show the reference channels.

The Si and InGaAs detector arrays have a combined spectral sensitivity range of 500 - 1650 nm. Each module features two isolated arrays providing individual High- and Low- sensitivity channels. The first array exhibits high quantum efficiency over the full wavelength range, while the signal in the second array is attenuated by about 15 dB, further extending the dynamic range for detection of high power laser pulses. The HARLID-362 module's field-of-view (FoV) is $\pm 45^\circ$ for both azimuth (horizontal plane) and elevation (vertical plane) angles. Its 6-bit Gray code design allows encoding of incident AoA with an angular resolution of $\pm 0.8^\circ$, in either azimuth or elevation, depending on the module's orientation. Three reference channels, illuminated for all incident angles, are provided in each array for baseline signal level determination.

Key Features and Benefits

- Spectral sensitivity range of 500 – 1650 nm
- 6-bit design for precise AoA encoding
- $\pm 0.8^\circ$ AoA accuracy - in either azimuth or elevation
- FOV is $\pm 45^\circ$ for both azimuth and elevation angles.
- Low- and High-sensitivity channels for wide dynamic range
- Three reference channels are provided in each photodiode array for baseline signal level determination.
- Manufactured using fully-automated robotic technology

Applications

- Laser Warning Receiver Systems
- Position determining systems
- Direction aids
- Vehicle guidance

EXCELITAS
TECHNOLOGIES

HARLID™ Series, HARLID-362 Module

High Angular Resolution Laser Irradiance Detector

Figure 1. Principle of Operation – HARLID. Shows varying binary code as a function of incident angle

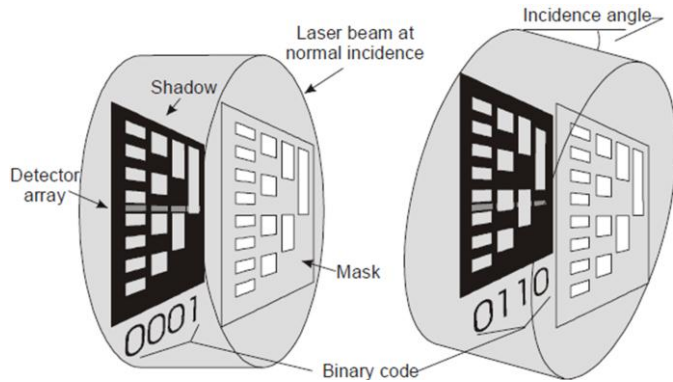

Table 1. High-sensitivity Array Specifications, HARLID-362

Parameter	Min	Typical	Max	Unit	Remarks / Conditions
Junction area (total)		0.5		mm ²	
Photosensitive area (per element)		0.075		mm ²	
Bias voltage (common)		12		V	
Breakdown voltage		25		V	
Spectral range	500		1650	nm	
Responsivity					
at 500 nm		0.2		A/W	
at 900 nm		0.4		A/W	
at 1064 nm		0.5		A/W	
at 1540 nm		0.7		A/W	
Wavelength band recognition through High-sensitivity Reference Channel 3					Si illumination detection through Pin H10 InGaAs illumination detection through Pin H8 1064 nm illumination through both detectors
Dark current (per element)			20	nA	
Noise current (per element)			0.5	pA/√Hz	
Capacitance (per element)		12		pF	Silicon and InGaAs elements
Rise and fall time		5		ns	
Guard ring dark current			200	nA	
Dynamic range		60		dB	In conjunction with low-sensitivity channels
Signal ratio		12		dB	Illuminated to shadowed elements
Attenuation of low sensitivity channel		15		dB	Relative to high-sensitivity channels
Field of view (FoV)			±45	°	For either azimuth or elevation angles
Angle-of-arrival (AoA) accuracy (RMS error) (σ)		0.8	1.0	°	Not including pointing error
Pointing error (μ)			1.0	°	

HARLID™ Series, HARLID-362 Module

High Angular Resolution Laser Irradiance Detector

Figure 2. Typical Spectral Responsivity of combined Si and InGaAs elements, HARLID-362

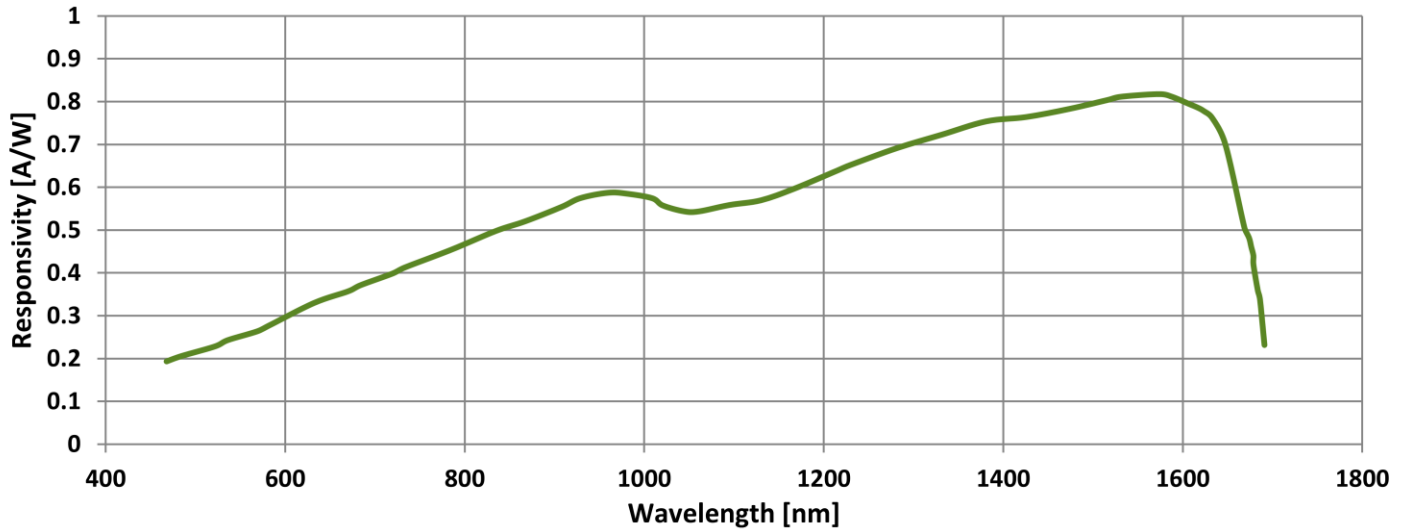

Figure 3. Mechanical Characteristics, HARLID-362. Reference dimensions shown

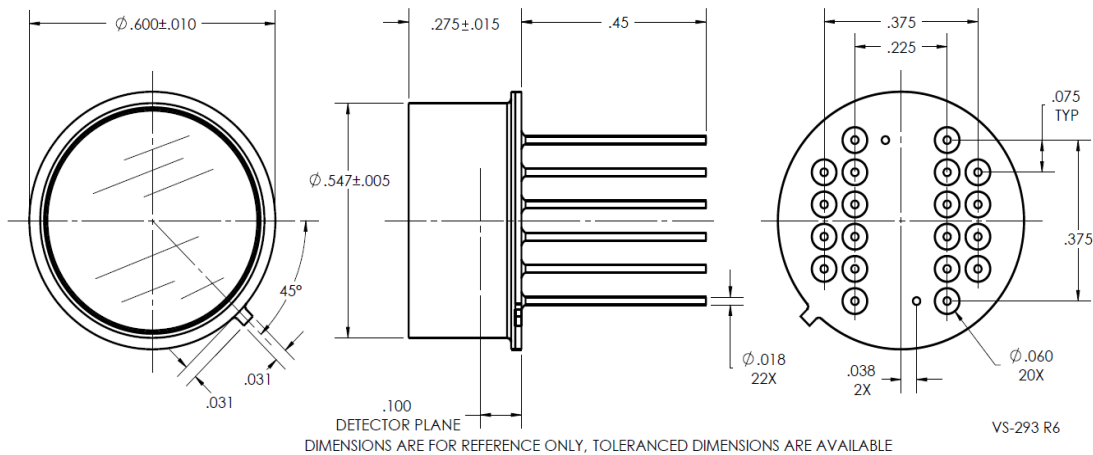
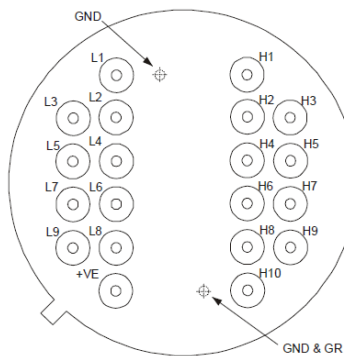

Figure 4. Pin Layout (Bottom View), HARLID-362



Pin ID	Function
H1, L1	Bit 3
H2, L2	Reference Channel 1
H3, L3	Bit 4
H4, L4	Bit 6
H4, L5	Reference Channel 2
H6, L6	Bit 5
H7, L7	Bit 1
L8	Low-sensitivity Reference Channel 3
H8	High-sensitivity InGaAs Reference Channel 3 (Note 1)
H9, L9	Bit 2
H10	High-sensitivity Si Reference Channel 3 (Note 1)
GND & GR	Case Ground and Guard Ring (Note 2)

Notes:

1. Separate pins connect to the high-sensitivity InGaAs and Silicon Reference Channel 3. This enables coarse wavelength-band identification. When both detectors respond, the incident laser beam is likely in the spectral transition region, specifically around 1064 nm.
2. The Guard Rings for the two detector arrays are bonded directly to the package.

Legend:

L – Low-sensitivity H – High-sensitivity GND – Ground GR – Guard Ring +VE – Common bias voltage (+12V)

HARLID™ Series, HARLID-362 Module**High Angular Resolution Laser Irradiance Detector****Table 2. Angle-of-Arrival (AoA) Encoding for High- and Low-sensitivity Channels, HARLID-362**

High Sensitivity AoA (°)	Low Sensitivity AoA (°)	AoA encoding						High Sensitivity AoA (°)	Low Sensitivity AoA (°)	AoA encoding					
		Bit 1	Bit 2	Bit 3	Bit 4	Bit 5	Bit 6			Bit 1	Bit 2	Bit 3	Bit 4	Bit 5	Bit 6
52.1	46.8	1	0	0	0	0	0	5.5	-7.0	0	1	0	0	0	0
50.7	45.1	1	0	0	0	0	1	3.9	-8.6	0	1	0	0	0	1
49.3	43.3	1	0	0	0	1	1	2.3	-10.1	0	1	0	0	1	1
47.9	41.6	1	0	0	0	1	0	0.7	-11.6	0	1	0	0	1	0
46.5	39.8	1	0	0	1	1	0	-0.8	-13.2	0	1	0	1	1	0
45.0	38.0	1	0	0	1	1	1	-2.5	-14.7	0	1	0	1	1	1
43.6	36.3	1	0	0	1	0	1	-4.1	-16.2	0	1	0	1	0	1
42.2	34.5	1	0	0	1	0	0	-5.7	-17.7	0	1	0	1	0	0
40.8	32.8	1	0	1	1	0	0	-7.3	-19.2	0	1	1	1	0	0
39.4	31.1	1	0	1	1	0	1	-9.0	-20.6	0	1	1	1	0	1
38.0	29.3	1	0	1	1	1	1	-10.6	-22.1	0	1	1	1	1	1
36.6	27.6	1	0	1	1	1	0	-12.3	-23.6	0	1	1	1	1	0
35.1	25.8	1	0	1	0	1	0	-13.9	-25.0	0	1	1	0	1	0
33.7	24.1	1	0	1	0	1	1	-15.6	-26.5	0	1	1	0	1	1
32.3	22.4	1	0	1	0	0	1	-17.3	-28.0	0	1	1	0	0	1
30.8	20.7	1	0	1	0	0	0	-19.0	-29.4	0	1	1	0	0	0
29.4	19.0	1	1	1	0	0	0	-20.7	-30.8	0	0	1	0	0	0
28.0	17.3	1	1	1	0	0	1	-22.4	-32.3	0	0	1	0	0	1
26.5	15.6	1	1	1	0	1	1	-24.1	-33.7	0	0	1	0	1	1
25.0	13.9	1	1	1	0	1	0	-25.8	-35.1	0	0	1	0	1	0
23.6	12.3	1	1	1	1	1	0	-27.6	-36.6	0	0	1	1	1	0
22.1	10.6	1	1	1	1	1	1	-29.3	-38.0	0	0	1	1	1	1
20.6	9.0	1	1	1	1	0	1	-31.1	-39.4	0	0	1	1	0	1
19.2	7.3	1	1	1	1	0	0	-32.8	-40.8	0	0	1	1	0	0
17.7	5.7	1	1	0	1	0	0	-34.5	-42.2	0	0	0	1	0	0
16.2	4.1	1	1	0	1	0	1	-36.3	-43.6	0	0	0	1	0	1
14.7	2.5	1	1	0	1	1	1	-38.0	-45.0	0	0	0	1	1	1
13.2	0.8	1	1	0	1	1	0	-39.8	-46.5	0	0	0	1	1	0
11.6	-0.7	1	1	0	0	1	0	-41.6	-47.9	0	0	0	0	1	0
10.1	-2.3	1	1	0	0	1	1	-43.3	-49.3	0	0	0	0	1	1
8.6	-3.9	1	1	0	0	0	1	-45.1	-50.7	0	0	0	0	0	1
7.0	-5.5	1	1	0	0	0	0	-46.8	-52.1	0	0	0	0	0	0

Notes:

1. All angles are with respect to the package axis.
2. The specified angle in each case is at the center of a typical $\pm 0.8^\circ$ range.
3. Shaded angles are outside the nominal field of view.
4. RMS Error for encoded angle-of-arrival (AoA) may increase at extreme elevation angles for azimuth encoding. If the HARLID is oriented for elevation encoding, the RMS error would increase for extreme azimuth angle.

Table 3. Absolute Maximum Ratings, Limiting Values, HARLID-362

Parameter	Min	Typical	Max	Units	Comments
Case temperature while operating, T_A	-40		85	°C	
Maximal incident power		1.2		kW/cm ²	Power used in standard testing, with 1060 nm, pulse width of 12 ns and pulse repetition rate of 2 kHz.
Damage threshold	100			kW/cm ²	Theoretical evaluation, no systematic test at this power level.

HARLID™ Series, HARLID-362 Module

High Angular Resolution Laser Irradiance Detector

Quality and Reliability

The HARLID-362 Module is compact and rugged, and has been designed to meet a full range of military specifications.

The following MIL-STD-883 criteria have been met:

1. Acceleration testing, method 2001.
2. Mechanical shock and sine vibration, method 2002 and 2007, respectively.
3. Temperature cycling, method 1010.

Ordering information

For HARLID-362 pricing, availability and customization for specific military requirements, please contact Excelitas Technologies.

About Excelitas Technologies

Excelitas Technologies is a global technology leader focused on delivering innovative, customized solutions to meet the lighting, detection and other high-performance technology needs of OEM customers.

From analytical instrumentation to clinical diagnostics, medical, industrial, safety and security, and aerospace and defense applications, Excelitas Technologies is committed to enabling our customers' success in their specialty end-markets. Excelitas Technologies has approximately 3,000 employees in North America, Europe and Asia, serving customers across the world.

Excelitas Technologies
22001 Dumberry Road
Vaudreuil-Dorion, Quebec
Canada J7V 8P7
Telephone: (+1) 450.424.3300
Toll-free: (+1) 800.775.6786
Fax: (+1) 450.424.3345
defense@excelitas.com

EXCELITAS
TECHNOLOGIES

For a complete listing of our global offices, visit www.excelitas.com/locations

© 2012 Excelitas Technologies Corp. All rights reserved. The Excelitas logo and design are registered trademarks of Excelitas Technologies Corp. All other trademarks not owned by Excelitas Technologies or its subsidiaries that are depicted herein are the property of their respective owners. Excelitas reserves the right to change this document at any time without notice and disclaims liability for editorial, pictorial or typographical errors.