

ACULED DYO Design-Your-Own



ACULED DYO gives you the flexibility to "Design-Your-Own" four-chip LED configuration to suit your specific needs.

Overview

Excelitas' ACULED® DYO™ gives customers the flexibility to "Design-Your-Own" four-chip LED configuration from a list of standard chip options including white chips, UV, IR, and sensor chips to suit specific lighting application requirements.

The custom design capability of the ACULED DYO complements Excelitas' standard ACULED VHL line and provides customers with a full range of standard and custom LED solutions based on the enhanced ACULED platform.

This Custom Design Guide demonstrates how you can "Design-Your-Own" ACULED DYO from a list of standard chips provided by Excelitas.

Key Features and Benefits

- Superior Color Mixing
- Based on multi Chip-on-Board (COB) technology
- 4 separate addressable chips
- Low thermal resistance
- Best-in-class heat sinking
- Superior "Through-Looking" (TL) mounting design
- Ultra-compact footprint
- Adjustable color temperature
- Outstanding brightness and luminous efficacy
- Designed for high current applications
- Fully RoHS-compliant

Applications

- Illumination
- Medical lighting
- Aircraft lighting
- Analytical lighting
- Signaling

Technical Support

- For additional technical support, please contact us at: elcos.sales@Excelitas.com

Figure 1. Layout and Dimensions of the ACULED

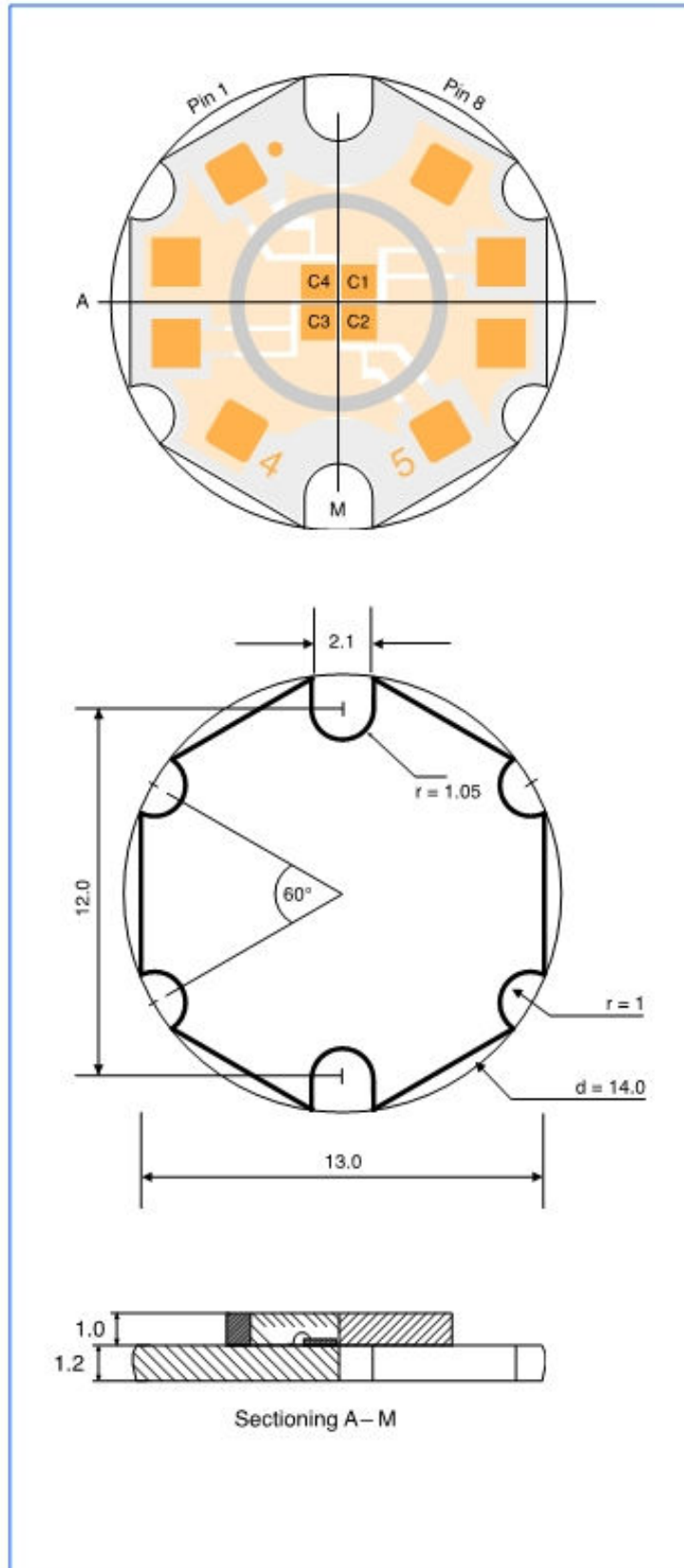

The ACULED Platform

The ACULED board is based on an Insulated Metal Core Substrate (IMS), also known as Metal Core PCB, made from copper and a highly sophisticated isolation material with a low thermal resistance between the copper and the chip pads. This package provides excellent heat dissipation and thermal management from the chip to the board's backside. The whole package has a low thermal resistance (down to 4.5 K/W), depending on the selected chip configuration. Adequate cooling has to be considered to avoid damaging the LED chips by overheating. When equipped with at least one high power LED chip, the ACULED must not run without appropriate cooling, even at lower currents, to dissipate the heat. Please refer to the Application Note "Thermal Management of the ACULED VHL" for more information about this issue. Figure 1 shows the principle layout of the ACULED VHL and DYO. The chips are placed in the middle of the board, protected by a ring and silicone resin encapsulation. The latter is transparent and suitable for a wide range of radiation from ultraviolet (UV) to infrared (IR). With ACULED high power LEDs, silicone achieves superior resistance to light radiation, mitigating degradation and maintains LED color purity over the LEDs' lifetime. The mechanical stress applied to the chips is lowest with silicone as compared to other encapsulation materials. As a result of its softness, pressure to the silicone area within the ring must be avoided. Please refer to the Application Note, "Handling of LED and Sensor Products Encapsulated by Silicone Resin," to learn more about handling silicone-based products like the ACULED.

It is recommended that the ACULED DYO is mounted by TL-Mounting. Please refer to the Application Note, "Mounting of the ACULED," for more information concerning TL-Mounting.

Table 1. Nomenclature (Order Number) of the ACULED DY0

Position	1	2	3	4	5	6	7	8	9	10	11	12	13	14	15	16	17	18	19	20	21	22	23	24	25	26	27	28	29	30	31	32
Order Number	A	C	L	0	1	-	O	D	-	n	n	n	-	C1	C2	C3	C4	-	E	n	n	-	C	0	1	-	L	-	n	n	n	0
Example*	A	C	L	0	1	-	O	D	-	0	1	7	-	R	G	B	G	-	E	1	0	-	C	0	1	-	L	-	0	0	0	0

*The example in the last row shows a 10 W version with a red, two green and a blue LED chip with ESD-protection.

Nomenclature

The general nomenclature of the ACULED DY0 is shown in Table 1. This is also the order number you build, depending on the chips you select. The order number of the ACULED is a 32-digit alphanumeric number representing the main features of your product. In Table 1, the white and blue cells contain code that cannot be changed, whereas green cells show the code you choose when configuring your ACULED DY0. Yellow cells indicate parts of the order number that depend on your choice but is filled in by Excelitas. You can leave the yellow cells open or just fill in zeros when ordering.

The specific positions in the order number are as follows:

- **Pos. 1 - 8:**

This given code identifies the ACULED as a DY0 type.

- **Pos. 10 - 12 (nnn):**

A three-digit alphanumerical number identifying the manufacturing code (BOM) of your specific customized ACULED DY0. This code is given to you by our factory with the order confirmation. Any time you order a specific configuration for the first time, please leave it blank or fill in "000". When ordering the same configuration again, please use the code you received the first time to ensure you'll get the same product again.

- **Pos. 14 - 17 (C1 C2 C3 C4):**

The code for the chips you want to use. The positions Cn (n = 1-4) in this number corresponds with the chip positions on the board (Figure 1). For the desired chip, put in the code from the chip menu described in Tables 3, 4, and 5. If you want a red chip on position C3 for example, please put in the code "R" on position C3 in the order number. Fill in "0" for pads not used.

- **Pos. 19 (E):**

Choose whether you want ESD-protection or not. Just put in "E" for ESD-protection chips (Zener diodes) or put in "0" for no ESD-protection. ESD protection includes all chip positions.

- **Pos. 20-21 (nn):**

Typical electrical power (rounded) of your ACULED DY0 in watts at rated current (usually 700 mA). This value depends on your choice of chip configuration and is supplied by Excelitas with the order confirmation.

An ACULED with an electrical power of 8.5 W, for example, would be indicated by "09". When ordering you can leave it blank or put in "00".

- **Pos. 23 - 25:**

Given code for the board. This code may be subject of choice in the near future.

- **Pos. 27:**

Code for the optical characteristic. Usually "L" is used for standard Lambertian emitters; "V" indicates a volume coating as used sometimes with white LEDs for example.

- **Pos. 29-31 (nnn):**

Alphanumerical binning code for your product. Position 29 indicates the overall flux at rated current whereas positions 30 and 31 show the wavelength or color of your product. These values depend on your choice of chip configuration and are given to you as typical numbers with the order confirmation.

- **Pos. 32:**

Not currently used.

- **Pos. 6, 9, 13, 18, 22, 26, 28:**

Used for separators. When ordering, please use them to make the product number readable.

Figure 2. Board Layout of the ACULED DYO

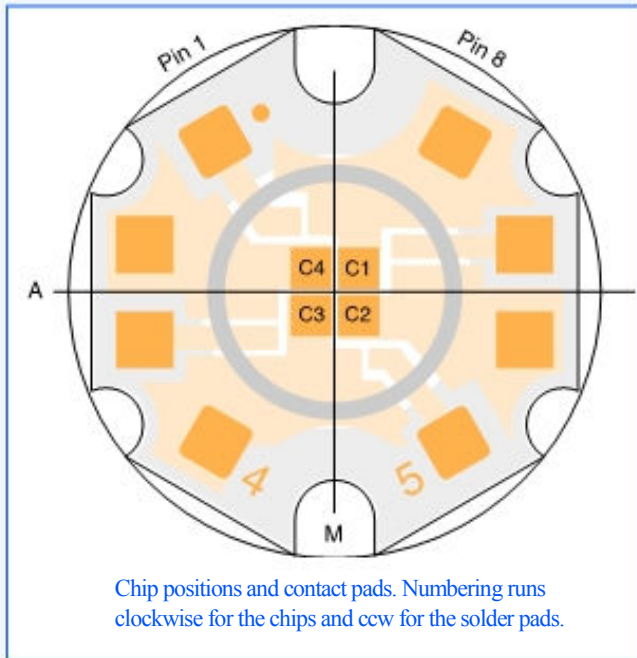

Table 2. Assignment of Chip Positions to Solder Pads (Typically)

Solder pad #	Chip position	Polarity non IR chips	Polarity IR chips	Polarity PD chips
1	C4	cathode (-)	anode (+)	anode (+)
2		anode (+)	cathode (-)	cathode (-)
3	C3	cathode (-)	anode (+)	anode (+)
4		anode (+)	cathode (-)	cathode (-)
5	C2	cathode (-)	anode (+)	anode (+)
6		anode (+)	cathode (-)	cathode (-)
7	C1	cathode (-)	anode (+)	anode (+)
8		anode (+)	cathode (-)	cathode (-)

Chip Postions

The positions of the chips on the ACULED board can be seen in Figure 2. Inside the encapsulation ring are pads for the chips, numbered clock-wise from C1 to C4. The numbers of the soldering pads run counter clock-wise from 1 to 8. The pad numbers 4 and 5 are printed on the board; pad number 1 can also be found easily by the small gold dot, which can be used as a reference for mounting. Table 2 shows the assignment between the pads, the chips' contacts and the soldering pads. If you require ESD-protection diodes, they will automatically be set inside the ring. Please note that the polarity for the IR chips is opposite to the rest.

You can easily connect the chips serially by connecting neighbored soldering pads like #2 - #3, #4 - #5, #6 - #7 or #8 - #1. This helps to make the design of your board as easy and flexible as possible. However, it is useful to carefully check the polarity of the chips used in your specific ACULED DYO, according to Tables 2 - 6 in the following section. If necessary, you can also get the chips serially connected internally with your DYO.

Chip Menu

There are three different kinds of chips you can choose from: visible LED chips (Tables 3 and 4), non-visible LED chips (Table 5), and sensors (Table 6).

The chip codes used in the order numbers, positions 14 - 17 as described in the previous section, show the color

corresponding to the wavelength of the chips you have chosen. For example, C1 = "R", C2 and C4 = "G" and C3 = "B" for an RGBG containing a red, two green and a blue chip. If you want to leave a position empty, please fill in "0". For example, if you want to configure an ACULED DYO with one yellow chip on position C1, a photodiode on position C3, and an NTC on position C4, but leave position C2 empty, fill in "Y0PN" for these chip codes in the order number.

Please note that the wavelength columns in Tables 3 - 6 show the dominant and peak wavelength range where chips can be chosen. This does not correspond to the spectral width of the chips.

ESD-Protection

ACULED DYO line offers you the ability to protect the LEDs with ESD-protection chips (Zener diodes). Since electronic semiconductor products are generally sensitive to ESD, which can result in non-reversible damage, it is highly recommended to take appropriate protection measures. Some materials are more sensitive to ESD than others. To protect LED chips with high ESD damage risk, we recommend using ESD-protection on the package level (i.e. the ACULED board). In our Chip List (Tables 3 - 6), we recommend that certain chips be used with ESD-protection. If any of these chips are selected, we suggest you place an "E" in position 19 of the order number to signify that ESD-protection is required. To learn more about the ESD-protection diodes please refer to the Application Note, "Driving the ACULED VHL."

How to Select

Four is the highest number of chips — beside ESD-protection chips — that can be used with the ACULED DYO. Of course, fewer chips are possible, if it works for your application. Since at high-power, efficacy decreases while heating increases, we recommend using two chips of the same type at lower current rather than using one chip at higher current. For example, it is more efficient to use two red chips at a current of 350 mA than using only one at 700 mA. Typical curves of efficiency, wavelength drift vs. current or temperature for the specific colors can be seen in the brochures for the ACULED VHL standard product line. Figure 3 shows an example of efficacy and wavelength drift for an all-green ACULED.

Recommendation Guidelines

Although the optimal combination of chips depends on your application, some general recommendations can be given. The following list can guide you in your DY0 selection. The codes used in the recommendations are the same as in Tables 3 - 6.

- **Color gamut:** If you want an ACULED with a high variety of adjustable colors (gamut), you should choose chips from Table 4 (VIS) with at least one red, one blue and one green. Since blue is the darkest of these colors relative to the human eye's sensitivity, two blue chips increase the flux of blue.
- **White light** can be generated by a mixture of RGB, as used with TV screens. Due to the high sensitivity of the human eye to green light, while green chips show lowest efficacy, the use of two green chips will achieve the best results. An RGBG-ACULED DY0 will lead to an appropriate white when all chips are driven at the same current. Though this product exists already as a standard ACULED VHL, you may want to use different wavelength combinations for your ACULED DY0, in order to have a different color gamut.
- **White light** can also be made by white LED chips (i.e. blue chips covered by a yellow phosphor.) These are available in different correlated color temperatures, as shown in Table 3. In a combination with RGB, you get a white with a large range of adjustable temperatures.

Table 3. White VIS Chips

Correlated Color Temperature [K]	Color	Chip Code	ESD rec.	Cathode On
-	White (unspecified)	W	yes	odd pads
4500	Ivory white	4	yes	odd pads
5700	Neutral white	5	yes	odd pads
6500	Daylight white	6	yes	odd pads

Table 4. Colored VIS Chips

Wavelength [nm]	Color	Chip Code	ESD rec.	Cathode On
445-455	Deep Blue	D	yes	odd pads
455-470	Blue	B	yes	odd pads
500-515	Cyan	C	yes	odd pads
515-540	Green	G	yes	odd pads
585-605	Yellow	Y	-	odd pads
605-620	Amber	A	-	odd pads
615-635	Red	R	-	odd pads
650-750	Far Red	F	-	odd pads

Table 5. UV and IR Chips

Wavelength [nm]	Radiation	Chip Code	ESD rec.	Cathode On
390-420	UV	U	yes	odd pads
830-880	IR1	I	-	even pads
930-1000	IR2	J	-	even pads

Table 6. Sensors

Type	Chip Code	Cathode On
Photodiode	P	even pads
NTC	N	

Figure 3. Examples of Efficacy and Wavelength Drift

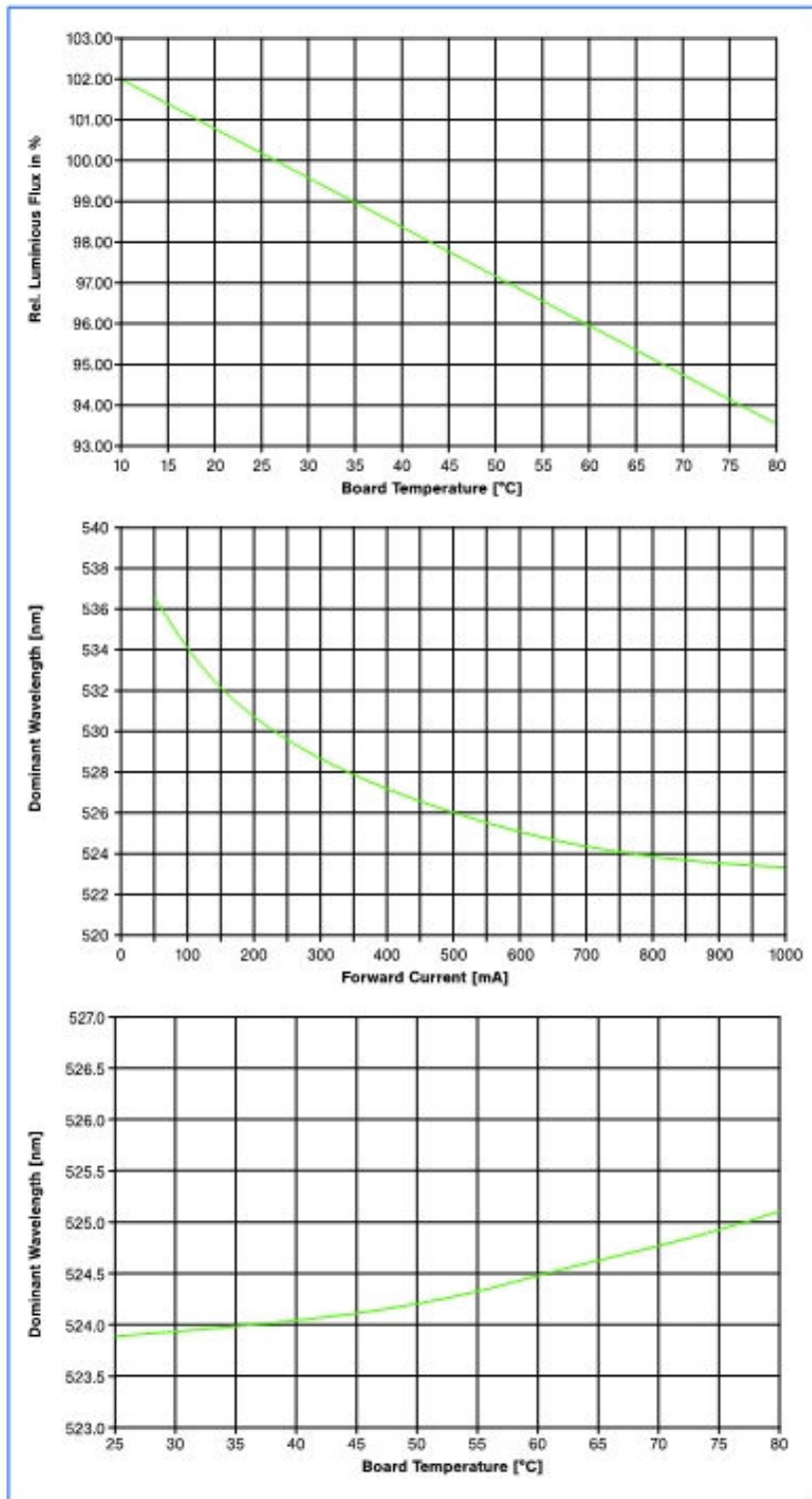

- In some applications, a good Color Rendering Index (CRI) is particularly important. Additional yellow or amber increases the CRI of the white generated by RGB. Therefore, Excelitas offers a standard ACULED VHL with RRGBY and other chip configurations. Also, a combination of 3 white chips with red, yellow or amber can improve the CRI on a customized design-your-own basis.
- To fine tune a particular color, it is beneficial to select chips within a fairly narrow color range. For example, if you want to achieve a fine-tunable red, you may want to select two red chips, a yellow chip, and an amber chip (i.e., RRYA-ACULED DYO).
- The intensity and the wavelengths of LED chips depend on the heating of the chip; therefore an NTC can be used to control the heat of the ACULED for further processing of color and intensity adjustment. Though NTCs can also be placed outside of the ACULED, placement on one of the chip pads is the most accurate way to control heating. Besides making adjustments, it can also be used to avoid over-heating. Please refer to the Application Note, "Driving the ACULED VHL", to learn more about NTC use with the ACULED DYO.
- Selecting a photodiode (PD) in your ACULED DYO can help you control the intensity and color for active adjustment. Although the PD measures intensity rather than color, it can be used for color adjustment by driving and measuring the colors sequentially. For example, an ACULED with a red, green and blue LED chip and a photodiode will give you an RGB light source which can provide an excellent variety of colors that can easily be controlled by the PD. When selecting PDs, please make sure that they are appropriate for the LED chips you select. For example, please ensure that the PDs are sensitive in the wavelength range of your LEDs. Please refer to the Application Note, "Driving the ACULED VHL," to learn more about PD use with the ACULED DYO.

Abbreviations

The following abbreviations are used in this Custom Design Guide.

ACULED®

The trademarked name for Excelitas' range of All Color Ultrabright LEDs.

BOM

Bill of Material

CRI

Color Rendering Index, value to measure the quality of light used for illumination purposes.

DYO™

Design Your Own, indicates an ACULED with customized chip configuration

ESD

Electro Static Discharge

IMS

Insulated Metal Substrate, PCB substrate made from aluminium or copper to provide excellent heat management

IR

Infra Red, radiation above 750 nm within the scope of this Design Guide

LED

Light Emitting Diode

NTC

Negative Temperature Coefficient, used as acronym for an NTC resistant. Thermistor to control (LED-) temperature.

PCB

Printed Circuit Board

PD

Photo Diode

pn junction

Layer in the LED chip, where positive (p) and negative (n) charged carriers recombine to light respectively radiation.

TL

Through-Looking (Mounting)

UV

Ultra Violet, with LEDs radiation below 420 nm within the scope of this Design Guide

VHL™

Very High Lumen. This is the name for the newest generation of standard monochromatic and multi-colored 4-chip ACULEDs.

VIS

Visible light, radiation between 440 and 750 nm (peak) within the scope of this Design Guide.

Excelitas Technologies
35 Congress Street
Suite 2021
Salem, MA 01970
P: (+1) 978-745-3200
(+1) 800-950-3441 (toll-free)
F: (+1) 978-745-0894
Email: generalinquiries@excelitas.com

Excelitas Technologies
Wenzel-Jaksch-Str.31
65199 Wiesbaden, Germany
P: (+49) 611 492 247
F: (+49) 611 492 170

Excelitas Technologies
47 Ayer Rajah Crescent #06-12
Singapore 139947
P: (+65) 6775 2022
F: (+65) 6775 1008



For a complete listing of our global offices, visit www.excelitas.com/ContactUs

©2011 Excelitas Technologies Corp. All rights reserved. Excelitas® is a registered trademark of Excelitas Technologies Corp. All other trademarks are the property of their respective owners.