

3-axis acceleration sensor application note

Hokuriku Electric Industry Co., Ltd.

Piezoresistive type 3-axis acceleration sensor

HAAM-326B

Calibration of sensor individual difference.

Feb, 2007 1st edition

Introduction

It aims at the ability of a user to understand the method of rectifying the individual difference of a piezoresistive type 3-axis acceleration sensor (HAAM-326B) in this application note.

This application note explains using the value which changed into the digital value the acceleration outputted analogically from the piezoresistive type 3-axis acceleration sensor (HAAM-326B).

Reference data: HAAM-326B catalog <http://www.hdk.co.jp/pdf/eng/e137507.pdf>

3-axis acceleration sensor application note (tilt detection)

3-axis acceleration sensor application note (pedometra)

3-axis acceleration sensor application note (throw-up, free-fall detection)

1 Composition

This application note explains using 78K0/KB2 (uPD78F0500) as an example CPU which connects to HAAM-326B.

Please refer to HAAM-326B catalog for electrical characteristics.

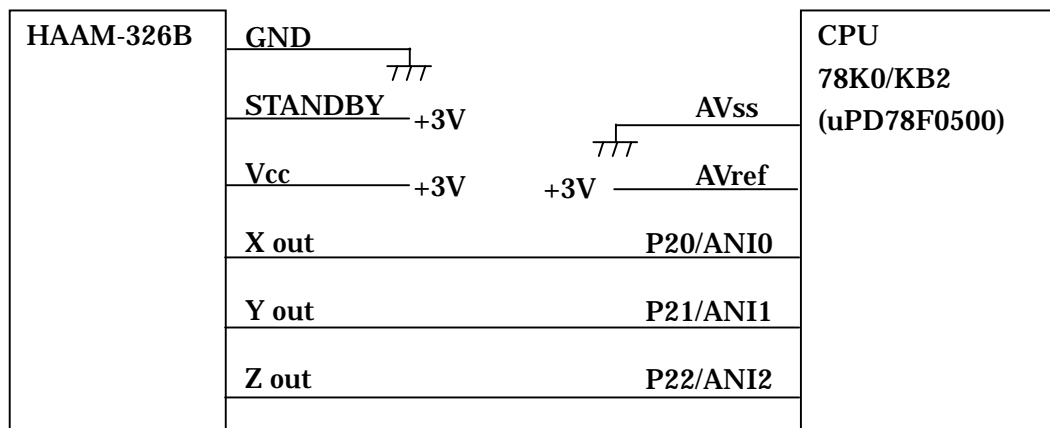

Figure 1 Connection of HAAM-326B and CPU

Piezoresistive type 3-axis acceleration sensor HAAM-326B

Calibration of sensor individual difference. Feb, 2007 1st edition

■ Input voltage and conversion result

There is a relation between analog input voltage that put into the analog input terminal (ANI0-ANI2) and logical A/D conversion result (10-bit A/D conversion result register) as the figure below.

The 78K0/KB2 used in this application note shows the figure below.

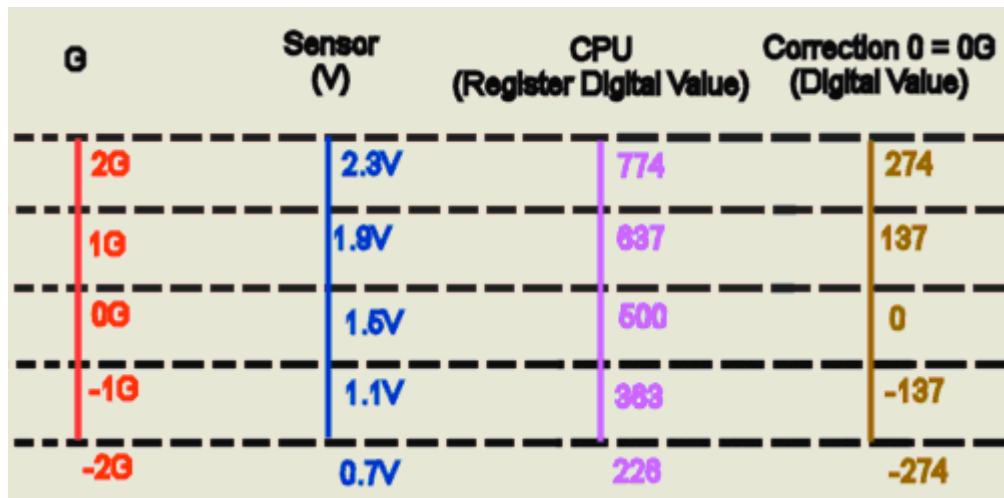

Figure 2 Input voltage and conversion result

■ Value to use on conversion result

In this application note, the digital value at 0G is considered as 0.

Figure 22 input voltage which adds offset to A/D conversion result and value of Correction0=0G (digital value) that is the conversion result will be used on later explanation.

■ Sampling rate

In this application note, XYZ is sampled every 4ms.

2 Necessity of calibration

As described in "Figure 2 Input voltage and conversion result", application is made on the basis of 0G= 0, 1G=137, and -1G=-137.

If sensor has error, application will malfunction only by degree of error.

In order to avoid it, it is necessary to correct the sensor error with application and to eliminate malfunction by bringing close to 0G=0, 1G=137, and -1G=-137.

Piezoresistive type 3-axis acceleration sensor

HAAM-326B

Calibration of sensor individual difference.

Feb, 2007 1st edition

3 Calibration method

Calibration method is shown below.

Firstly, obtain sensor individual difference by (1) - (6) below at initial start-up.

Regularly, calibrate sensor individual difference of XYZ axis by (7) below.

- ① Place sensor so that plus direction of Z-axis turns upward and XY axis become level. (Right figure)

Set 0 - digital value of X-axis = XOffset1

Set 0 - digital value of Y-axis = YOffset1

Set absolute value of Z-axis digital value = ZFullScale1

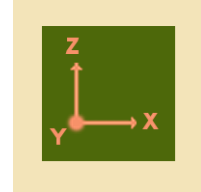

- ② Place sensor so that plus direction of Z-axis turns downward and XY axis become level. (Right figure)

Set 0 - digital value of X-axis = XOffset2

Set 0 - digital value of Y-axis = YOffset2

Set absolute value of Z-axis digital value = ZFullScale2

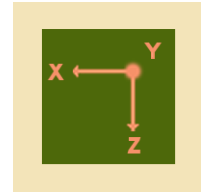

- ③ Place sensor so that plus direction of X-axis turns upward and YZ axis become level. (Right figure)

Set 0 - digital value of Z-axis = ZOffset1

Set absolute value of X-axis digital value = XFullScale1

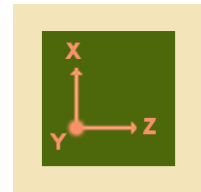

- ④ Place sensor so that plus direction of X-axis turns downward and YZ axis become level. (Right figure)

Set 0 - digital value of Z-axis = ZOffset2

Set absolute value of X-axis digital value = XFullScale2

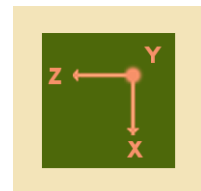

- ⑤ Place sensor so that plus direction of Y-axis turns upward and XZ axis become level. (Right figure)

Set absolute value of Y-axis digital value = YFullScale1

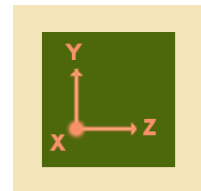

- ⑥ Place sensor so that plus direction of Y-axis turns downward and XZ axis become level. (Right figure)

Set absolute value of Y-axis digital value = YFullScale2.

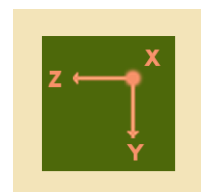

Piezoresistive type 3-axis acceleration sensor HAAM-326B

Calibration of sensor individual difference. Feb, 2007 1st edition

⑦ Calibrate sensor individual difference of XYZ axis by calculation below.

$$X\text{Offset} = (X\text{Offset1} + X\text{Offset2}) / 2$$

$$Y\text{Offset} = (Y\text{Offset1} + Y\text{Offset2}) / 2$$

$$Z\text{Offset} = (Z\text{Offset1} + Z\text{Offset2}) / 2$$

$$a = (X\text{FullScale1} + X\text{FullScale2}) / 2$$

$$b = (Y\text{FullScale1} + Y\text{FullScale2}) / 2$$

$$c = (Z\text{FullScale1} + Z\text{FullScale2}) / 2$$

$$X\text{FullScale} = (137)^2 / a$$

$$Y\text{FullScale} = (137)^2 / b$$

$$Z\text{FullScale} = (137)^2 / c$$

Calibrated X digital value =

$$X\text{-axis digital value} \times X\text{FullScale} / 137 \text{ (Scale of 1G)} + X\text{Offset}$$

Calibrated Y digital value =

$$Y\text{-axis digital value} \times Y\text{FullScale} / 137 \text{ (Scale of 1G)} + Y\text{Offset}$$

Calibrated Z digital value =

$$Z\text{-axis digital value} \times Y\text{FullScale} / 137 \text{ (Scale of 1G)} + Z\text{Offset}$$

(Note) ideal value 137 at the time of 1G

Piezoresistive type 3-axis acceleration sensor HAAM-326B

Calibration of sensor individual difference. Feb, 2007 1st edition

Following figure describes example of offset in case each digital value of (1) ~ (6) is below at the time of initial start-up.

- X=-4, Y= 0, Z=-140 at the time of (1)
- X= 3, Y=-10, Z= 150 at the time of (2)
- X=-135, Y=-2, Z=-1 at the time of (3)
- X= 143, Y=-2, Z=-1 at the time of (4)
- X=-3, Y=-142, Z=-3 at the time of (5)
- X=-15, Y= 150, Z=-10 at the time of (6)

No.	Digital value	XOffSet1	XFullScale1	YOffSet1	YFullScale1	ZOffSet1	ZFullScale1
		XOffSet2	XFullScale2	YOffSet2	YFullScale2	ZOffSet2	ZFullScale2
(1)	X=-4 Y=0 z=-140	XOffSet1 =4		YOffSet1 = 0			ZFullScale1 = 140
(2)	X=3 Y=-10 z=150	XOffSet2 = -3		YOffSet2 = 10			ZFullScale2 = 150
(3)	X=-135 Y=-2 z=-1		XFullScale1 = 135			ZOffSet1 = 1	
(4)	X=143 Y=-2 z=-2		XFullScale2 = 143			ZOffSet2 = 2	
(5)	X=-3 Y=-142 z=-3				YFullScale1 = 142		
(6)	X=-15 Y=150 z=-10				YFullScale2 = 150		

Figure 3 Table of each offset, full-scale

Piezoresistive type 3-axis acceleration sensor

HAAM-326B

Calibration of sensor individual difference.

Feb, 2007 1st edition

■ Example of calibration

Example of calibration is explained on X-axis.

Digital value (offset, full scale) put on X-axis when not adding operation to a sensor is measured by carrying out following 1~4.

1. Places sensor so that plus direction of Z-axis turns upward and XY axis become level. (Right figure)

Set 0 - digital value of X-axis = XOffset1

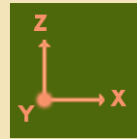

2. Place sensor so that plus direction of Z-axis turns downward and XY axis become level. (Right figure)

Set 0 - digital value of X-axis = XOffset2

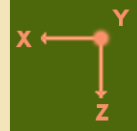

3. Place sensor so that plus direction of X-axis turns upward and YZ axis become level. (Right figure)

Set absolute value of X-axis digital value = XFullScale1

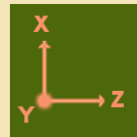

4. Place sensor so that plus direction of X-axis turns downward and YZ axis become level. (Right figure)

Set absolute value of X-axis digital value = XFullScale2.

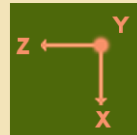

Suppose that values temporarily calculated by 1-4 were below.

1. XOffset1 = 3
2. XOffset2 = -4
3. XFullScale1 = -135
4. XFullScale2 = 143

Piezoresistive type 3-axis acceleration sensor HAAM-326B

Calibration of sensor individual difference. Feb, 2007 1st edition

When X-axis aims horizontal direction like XOffset1, XOffset2, entire digital value applied to X-axis is 7.

When X-axis becomes perpendicular like XFullScale1, XFullScale2, entire digital value applied to X-axis became 278.

However, they expressed to "Figure 4 before and after calibration", it became a state of "before calibration".

And it turns out that equal gravity (acceleration) is not applied between plus direction and minus direction when based on 0 to X-axis.

Ideal digital value for each axis when placing a sensor horizontally, is

Axis applied gravity 1G -> digital value 137 (-137),

Axis applied gravity 0G -> digital value 0.

By calibrating gap like "after calibration" as shown in " Figure 4 Acceleration before and after calibration", and also calibrating in order to bring close to ideal value (137, -137), error correction can be made on individual sensor.

Therefore, even if sensors have individual difference, similar operation can be made among the sensors.

Piezoresistive type 3-axis acceleration sensor
 Calibration of sensor individual difference.

HAAM-326B
 Feb, 2007 1st edition

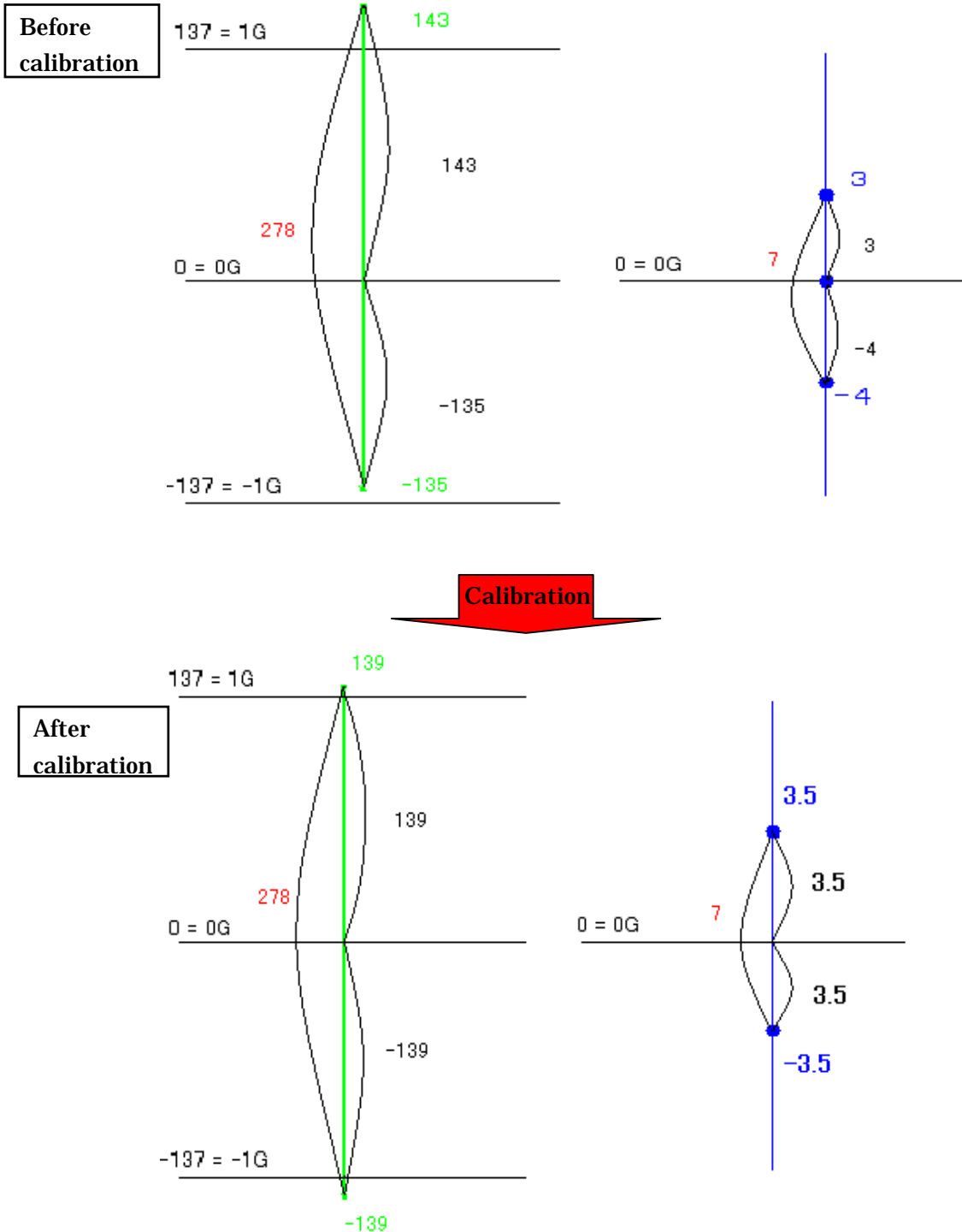

Figure 4 Acceleration before and after calibration

Piezoresistive type 3-axis acceleration sensor

HAAM-326B

Calibration of sensor individual difference.

Feb, 2007 1st edition

4 Response speed

Response speed of sensor is described below.

When judging move, vibration, shock, sensor is doing below.

1. Detect stopped state (idle)
2. Detect move start
3. After move start, judge move or vibration or shock and processing
4. Judged that move was completed (sensor idle state)
5. Return to 1 (carry out this loop)

Since above 1 - 4 makes one operation, response speed will become blunt if spend time on detection of move or stop. Response speed will become fast if time of detection carry out quickly.

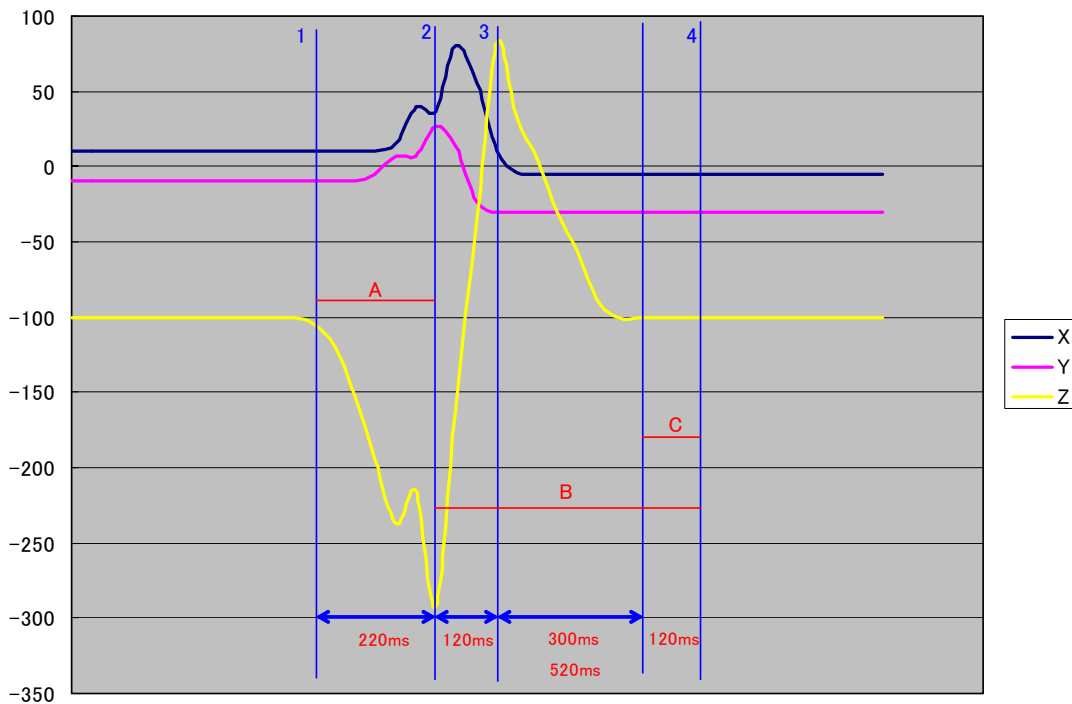
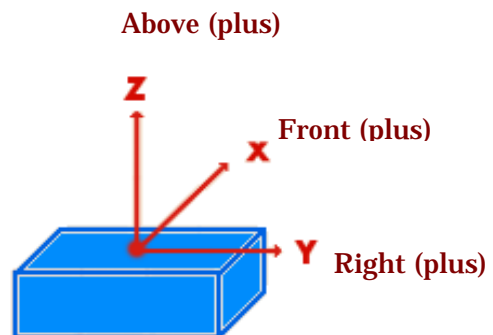

Figure 5 Move to Z-axis (plus) direction



Piezoresistive type 3-axis acceleration sensor HAAM-326B

Calibration of sensor individual difference. Feb, 2007 1st edition

- A section is time to judge that move was performed to a sensor when moving the sensor. (It is 220msec in this application note)
It also judges in which direction the sensor moved by finding whether wave fluctuated in plus or minus direction in A section.
(In case of Z-axis, it moved upward when A section is minus and it moved downward when it is plus.)
- B section is total time to judge sensor stopped after detecting first wave maximum. (It is 520msec in this application note.)
- If C section is time to continue counting and to judge sensor stopped unless wave does not fluctuate greatly during the count. Until judged that sensor stopped, other operation applied to the sensor is not accepted.
- Response speed
 - ① Section that judged to be move is A section which is from move start to detection of maximum value. But, if judged that move continues even after finding maximum value, incorrect move will be judged.
Therefore, in order to judge next move once moving a sensor, B section which judge move end after detecting maximum value, is needed. And wave's up-down must be disregarded in B section after A section ends.
This section is about 400msec~1second. The stronger the force that sensor was moved with, the longer the time until wave settles (C section).
Moreover, if new operation is added during B section, wave up-down repeats and judgment of move end will take longer.

Response speed is decided by the length of this B section.