

Torque Sensor

with Dual-Range-Option

Type 4503A...

Type 4503A... torque sensors with built-in speed sensor operate on the strain gage principle. An integral, digital measurement conditioning system produces analog or digital output signals.

- Rated torque: 0,2 ... 5 000 N·m
- Ratio for second range: 1:10 or 1:5 of rated torque
- Speed ranges up to 50 000 1/min
- Accuracy class in standard measuring range: 0,1
In the extended measuring range: 0,2
- Integral speed sensor
- Serial data output RS-232C for torque signals

Additional advantages of second range:

- Natural overload protection of smaller range because of special design
- One sensor for two separately calibrated measuring ranges

Description

The version with a second measuring range (optional) is ideal for applications with a high peak torque but moderate operating torque. A torque sensor with only one measuring range would have to be chosen to withstand the peak torque. As a result it would, however, be oversized for measuring the operating torque actually of interest.

The dual range sensor offers the advantage of range switching, which allows highly accurate measurement of both the peak and particularly the operating torque.

Power is supplied and the measurement signals transferred between the rotating shaft and the case without contact. In addition to suitable mounting of the shaft, low production tolerances and high grade balancing, this is a further prerequisite for the high speed limit of up to 50 000 1/min achieved with the "H" version.

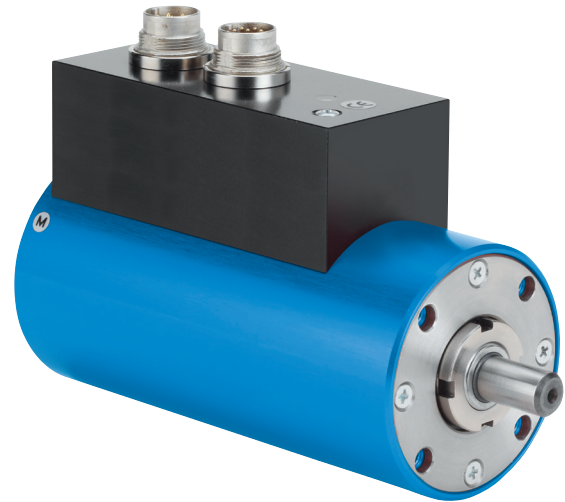

Application

The Type 4503A... torque sensors are used:

- In automotive and vehicle engineering
- In the aeronautical industry
- In mechanical and process plant engineering
- In electric motor manufacture

They are universal in application, being suitable for the development laboratory, production or quality assurance.

With a torque sensor Type 4503A... you will solve your measurement requirement. They are typically used for testing of electric motors, generators, drive performance, measurement of transmission or spindle drive friction, at a manual workstation or in networked, automated production cells.

4503A_000-595e-05.12

Technical Data

Mechanical Basic Data

Measuring range	N·m	±0,2 ... 5 000
Rated torque M_{nom}	N·m	0,2 ... 5 000
Overload capacity at limiting torque		1,5 x M_{nom}
Alternating torque		0,7 x M_{nom}
Rupture torque		4 x M_{nom}
Built-in speed sensor	pulses/revolut.	1x60
speed measurement only		
speed and angular measurement (version "W")		2x360 ("W") 90° displaced, TTL up to 7 000 1/min
Nominal Speed		depending on measuring range and design (see details)
Balancing class Q		
for version "L"		6,3
for version "H"		2,5
Housing material		Anodized aluminum
Exception: size 4 and 5, version "H"		stainless steel
Protection class		IP40

General Electrical Specifications

Cut-off frequency -3 dB for voltage output	kHz	1
Output signal	VDC	±0 ... 5
at M_{nom} (rated value)	VDC	5*
Load resistance	kΩ	>10
Operating temperature range (rated temperature range)	°C	10 ... 60
Service temperature range	°C	0 ... 70

* Further options available

Storage temperature range	°C	-25 ... 80
100 % control input	VDC	"On" 3,5 ... 30 "Off" 0 ... 2
Supply voltage	VDC	11 ... 30
Power consumption	W	<3
Electrical connection		12 pin/7 pin built-in connector

Electrical Measuring Data – Standard Measuring Range 1:1

Rated torque [N·m]	0,2 ... 2	5 ... 5 000
Accuracy class	0,1	0,1
Linearity error [% FSO] including hysteresis	<±0,1	<±0,1 optional version: <±0,05
Temperature influence zero point	% FSO/°C	<±0,005
Temperature influence nominal value	% FSO/°C	<±0,01
Torque control signal for voltage output/frequency output	%	100 ±0,2

Electrical Measuring Data – Extended Measuring Range 1:5, 1:10

Rated torque	N·m	1 ... 5 000
Accuracy class		0,2
Linearity error including hysteresis	% FSO	<±0,2
Temperature influence zero point	% FSO/°C	<±0,02
Temperature influence nominal value	% FSO/°C	<±0,02
Torque control signal for voltage output/frequency output	%	100 ±0,3

Principle of Function

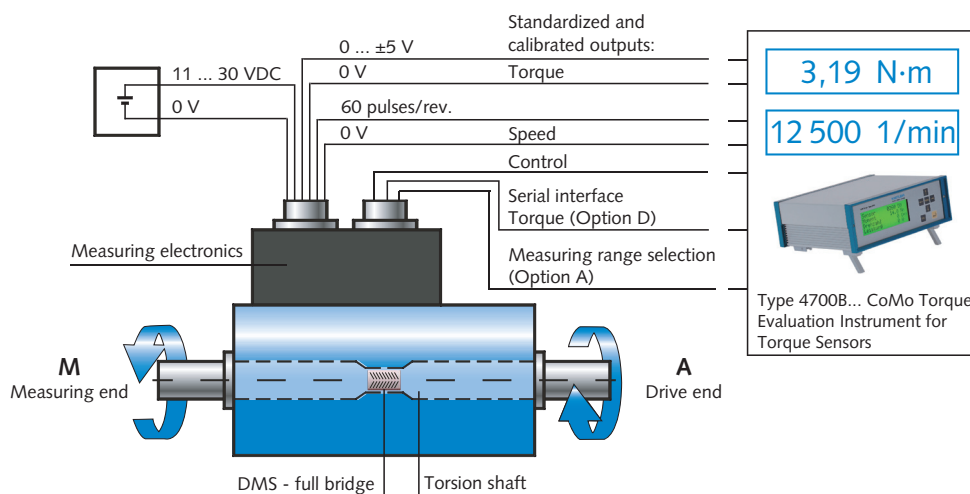

4503A_000-595e-05.12

Measuring Ranges and Maximum Speed

Measuring range N·m	Version	
	"L" (low speed) 1/min	"H" (high speed) 1/min
0,2	20 000	50 000
0,5	20 000	50 000
1	20 000	50 000
2	20 000	50 000
5	20 000	50 000
10	20 000	50 000
20	20 000	50 000
50	12 000	30 000
100	12 000	30 000
200	8 000	20 000
500	8 000	20 000
1 000	8 000	20 000
2 000	5 000	10 000
5 000	5 000	10 000

Spring Constant and Inertia of Mass

Measuring range N·m	Spring constant N·m/rad	Inertia of mass kgcm ²	
		Measuring end	Drive end
0,2	40	0,0023	0,25
0,5	40	0,004	0,14
1	230	0,0054	0,16
2	350	0,006	0,17
5	450	0,006	0,17
10	700	0,008	0,19
20	800	0,008	0,19
50	9100	0,54	1,16
100	13 500	0,54	1,16
200	60 000	4	8,3
500	100 000	4,2	8,3
1 000	135 000	4,2	8,3
2 000	520 000	61	85
5 000	720 000	61	85

Limit Values for Dynamic Load

Version "L" (low speed)

Size	Measuring range N·m	Weight kg	Speed 1/min	Measuring end		Drive end	
				Lateral force N max.	Axial force N max.	Lateral force N max.	Axial force N max.
1	0,2	0,8	20 000	10	50	100	50
	0,5			25	50	150	40
	1			50	50	200	40
2	2	1,4	20 000	100	50	200	40
	5			200	50	200	40
	10			200	50	200	40
	20			200	50	200	40
3	50	2	12 000	200	100	400	800
	100			400	200	800	800
4	200	5	8 000	400	200	2 000	2 000
	500			1 000	500	2 000	2 000
	1 000			2 000	1 000	2 000	2 000
5	2 000	18	5 000	4 000	2 000	10 000	10 000
	5 000			10 000	5 000	10 000	10 000

Version "H" (high speed)

Size	Measuring range N·m	Weight kg	Speed 1/min	Measuring end		Drive end	
				Lateral force N max.	Axial force N max.	Lateral force N max.	Axial force N max.
1	0,2	0,9	50 000	10	50	100	50
	0,5			25	50	150	50
	1			50	50	200	50
2	2	1,5	50 000	75	50	200	50
	5			100	50	200	50
	10			100	50	200	50
	20			100	50	200	50
3	50	2,1	30 000	200	100	300	100
	100			200	100	300	100
4	200	5,1	20 000	400	200	400	200
	500			400	200	400	200
	1 000			400	200	400	200
5	2 000	18	10 000	4 000	2 000	4 000	2 000
	5 000			4 000	2 000	4 000	2 000

Version "H" size 4 and 5 consist of stainless steel (not blue anodized)

4503A_000-595e-05.12

Dimensions

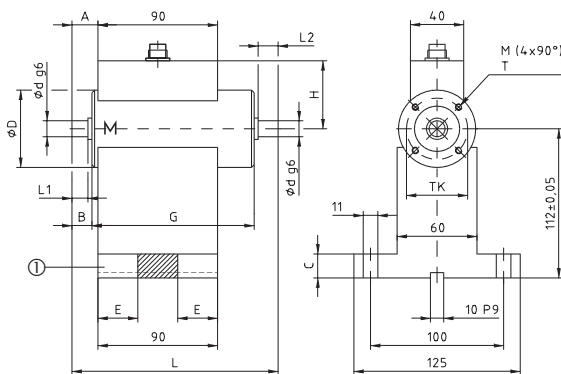

Fig. 1: Type 4503A... size 1 ... 3

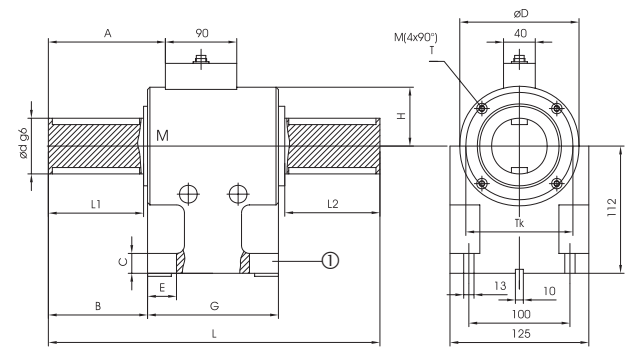
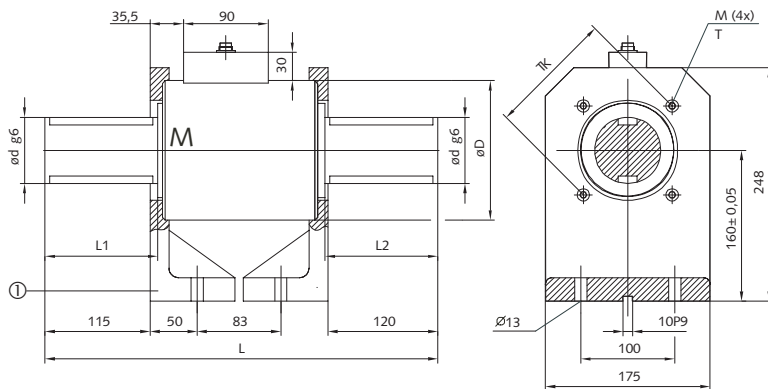

Fig. 2: Type 4503A... size 4



① = Option mounting base "GU"
M = Measuring end

Fig. 3: Type 4503A... size 5

Dimensions in mm

Size	1			2		3	4	5
Rated torque N·m	0,2	0,5	1	2/5	10/20	50/100	200/500/ 1 000	2 000/5 000
L	161	160,5	159	163	166	180	267	418
L1	16	16	16	18	20	28	60	120
L2	16	16	16	18	20	28	61	120
øD	58	58	58	58	58	78	98	148
øD g6	9	9	9	10	12	22	42 ¹⁾	70 ²⁾
A	21,5	23,5	22	24	25	43,5	83	150,5
B	17	19	17,5	19,5	20,5	34	64,5	122
C		18		18		18	15	22
E		30		30		30	32	-
G		122		122		113	137	169
H		54		54		66,5	77,5	104,2
TK		46		46		64	87	132
M		M5		M5		M6	M6	M8
T		10 deep		10 deep		12 deep	12 deep	16 deep

¹⁾ both shaft ends with keyways (12 P9x50/2x180°) according to DIN 6885, Bl. 1
²⁾ both shaft ends with keyways (20 P9x110/2x180°) according to DIN 6885, Bl. 1

4503A_000-595e-05.12

Electrical Connections

Pin Allocation of the 12 Pin Built-in Standard Connector

	Function	PIN	Description
	Supply	F A	+U _B GND
	Shield	M	In sensor connected to housing
	Torque output	C	U _A ±5 VDC at ±M _{nom} at >2 kΩ 5 VDC at control signal activation R _c = 10 Ω, output short circuit proof relating to AGND Ground relating to U _A
		D	AGND
	Speed-/angle of rotation pulses	H	Track A Open collector – output (open collector) Internal 1 kΩ resistance to 5 VDC (pull up), TTL-level
		G	Track B
		J K	Track Z Not connected
	100 % control input	K	Control Off: 0 ... 2 VDC On: 3,5 ... 30 VDC R _K = 10 kΩ
	RS-232C interface to the CoMo Torque	B	TXD
		L	RXD
	Digital ground potential	E	DGND Ground relating to speed- or angle of rotation pulses, control input, digital connection to CoMo Torque

Pin Allocation of the 7 Pin Built-in Connector for Range Switch Option A1, A2 or D1

	Function	PIN	Description
	Measuring range selection	1	Amplification Normal (1:1) with 0 ... 2 VDC Extended (1:10/1:5) with 3,5 ... 30 VDC
	100 % control input	4	Control Off: 0 ... 2 VDC On: 3,5 ... 30 VDC
7		OGND Opto isolated ground for measuring range selection and control input	
RS-232C interface	5	TXD	Serial send path of the torque sensor
	6	RXD	Serial receive path of the torque sensor
	3	DGND	Ground relating the RS-232C interface
		2	For company internal functions, don't use!

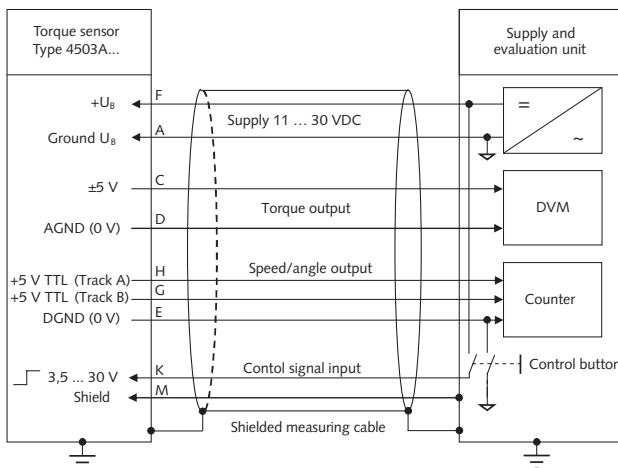

Fig. 4: Connection diagram of 12 pin built-in connector (standard)

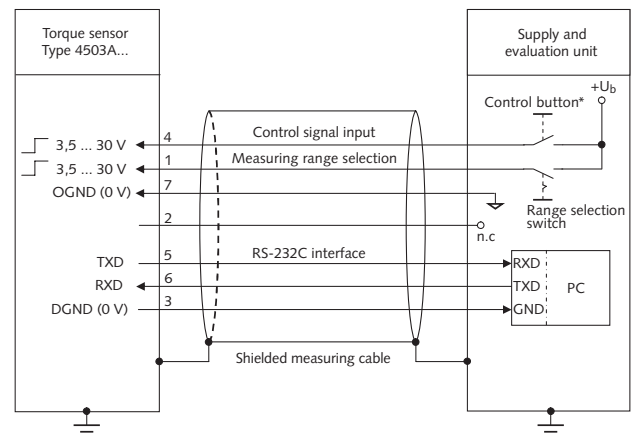

Fig. 5: Connection diagram of 7 pin built-in connector
Option A1/A2: range selection
Option D1: RS-232C interface

4503A_000-595e-05.12

Included Accessories

- None

Optional Accessories

- | | |
|---|---------------|
| • Mounting base "GU", for measuring ranges 0,2 ... 20 N·m | KSM003799 |
| • Mounting base "GU", for measuring ranges 50 ... 100 N·m | KSM003801 |
| • Mounting base "GU", for measuring ranges 200 ... 1 000 N·m | KSM003922 |
| • Mounting base "GU", for measuring ranges 2 000 ... 5 000 N·m | KSM004020 |
| • Female connector with solder eye 12 pin | KSM000703 |
| • Female connector with solder eye 7 pin | KSM000517 |
| • Connection cable, 5 m, 12 pin | KSM007203 |
| • Connection cable, 5 m, 12 pin – open ends | KSM124970-5 |
| • Connection cable, 5 m, 7 pin – open ends | KSM219710-5 |
| • Connection cable 2,5 m, 12 pin – CoMo Torque | KSM186420-2,5 |
| • Connection cable 5 m, RS-232C 7 pin/D-Sub 9 pin | KSM214680-5 |
| • ControlMonitor CoMo Torque Evaluation instrument for torque sensors | 4700B... |

Ordering Key

Type 4503A

Measuring Ranges in N·m

0,2 (1) (2)	0,2
0,5 (1) (2)	0,5
1 (2)	1
2 (2)	2
5	5
10	10
20	20
50	50
100	100
200	200
500	500
1 000	1K
2 000	2K
5 000	5K

Pulses per Revolution

Low speed 60	L
High speed 60	H
Low speed 360	W

Range Selection

Without	00
Dual range sensor, rated torque 1:10 (Measuring range selection)	A1
Dual range sensor, rated torque 1:5 (Measuring range selection)	A2

Output Signal

Output signal ±5 VDC	00
Output signal ±10 VDC	B1
100 ±40 kHz (TTL)	B2
100 ±40 kHz (24 V)	B3
100 ±40 kHz (±5 push-pull)	B4

Increased Accuracy

Without	0
Increased accuracy	C

Interface

Without	00
Interface RS-232C incl. calibration	D1

- (1) no **Range Selection A1** and **A2** possible
- (2) no **Increased Accuracy C** possible

Order example without options:

Type 4503A50L0000000

Torque sensor with 1 measuring range: rated torque 50 N·m, Version L: max. speed 12 000 1/min, Standard output signal ±5 VDC

Order example with options:

Type 4503A50LA1B20D1

Vesion L : max. speed 12 000 1/min, Torque sensor **A1** with 2 measuring ranges: 1. rated torque 50 N·m, 2. rated torque 5 N·m, **B2**: frequency output TTL, **0**: without increased accuracy, **D**: RS-232C interface

4503A_000-595e-05.12