

<b>HEIMANN Sensor GmbH</b>		Product Specification: <b>IR Lamp HSL 5/60</b>
Author(s): M. Schulze	Rev.: R 01 / 10.11.2005	Page 1 of 3

## Specification IR Lamp

**HSL 5/60**

**Part No. 4004**

**R 01**

**Author(s):**

**M. Schulze**

### Revision History

Version	Date	Remarks
R 01	10.11.2005	1. Draft of HEIMANN Sensor GmbH

<b>HEIMANN Sensor GmbH</b>		Product Specification: <b>IR Lamp HSL 5/60</b>
Author(s): M. Schulze	Rev.: R 01 / 10.11.2005	Page 2 of 3

## 1. Purpose, Scope

The lamp series HSL from Heimann Sensor are cheap and reliable IR sources for nondispersive infrared (NDIR) gas detection by IR light absorption, e.g. for gases like CO<sub>2</sub> and hydrocarbons. This IR lamp combines a small design, good processability and has a long lifetime and meets the requirements of the European Union RoHS (Regulation of Hazardous Substances) Directive.

## 2. Absolute Maximum Ratings

Parameter	Limits			Units	Conditions
	Min	Typ.	Max		
ambient temperature	-40	25	100	°C	operation / storage

## 3. General and Electrical Parameter

Parameter	Typ. Value	Tolerance	Units	Conditions
Voltage	5		V	
Current *1)	60		mA	after settling time of 30..100 msec
Brightness *2)	0.05	± 25 %	MSCP	for visible light, MSCP -> mean spherical candle power
Filament	C-2R			
Average lifetime	100000		h	Supply voltage = 5V AC

\*1) Because of the low resistance value of the cold filament, the lamp is being exposed to a surge when switched on. The intensity of the surge is depending on the colour temperature (Kelvin) of the specific lamp. The inrush current is 8 to 12 times as much as the operational current. The rising time up to reaching the operating temperature, which means stabilisation of the lamp current, is about 30 to 100 milliseconds depending on the current consumption. The inrush current can be reduced by constant preheating of the filament. The preheating voltage should warm the filament beneath the glowing status (less 1000 degrees Kelvin) what is reached mostly at 10% to 15% of the operational voltage. Preheating of the filament may reduce the inrush current by 50%.

\*2) The light values can be converted to lumen by multiplication of the MSCP-data with  $4\pi$  (12.57).

<b>HEIMANN Sensor GmbH</b>		<b>Product Specification: IR Lamp HSL 5/60</b>
Author(s): M. Schulze	Rev.: R 01 / 10.11.2005	Page 3 of 3

#### 4. Lamp Drawing

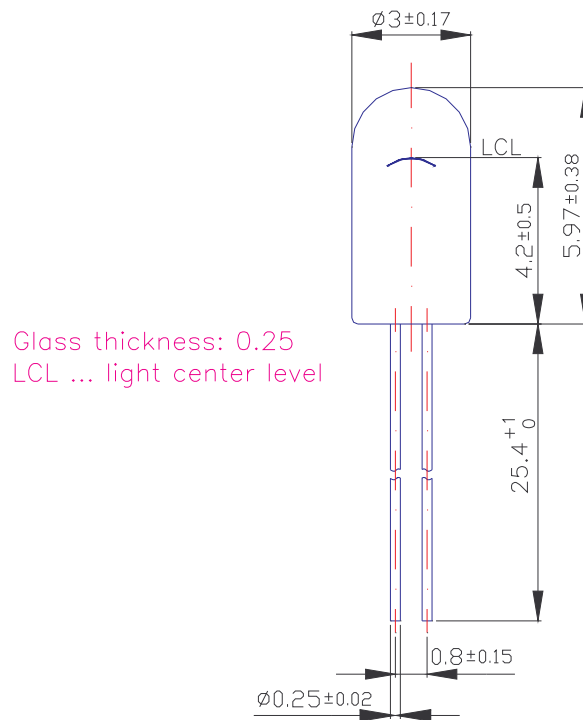

#### 5. Limited Spectral Range

Due to the glass properties the spectral range of the emitted radiation is limited.

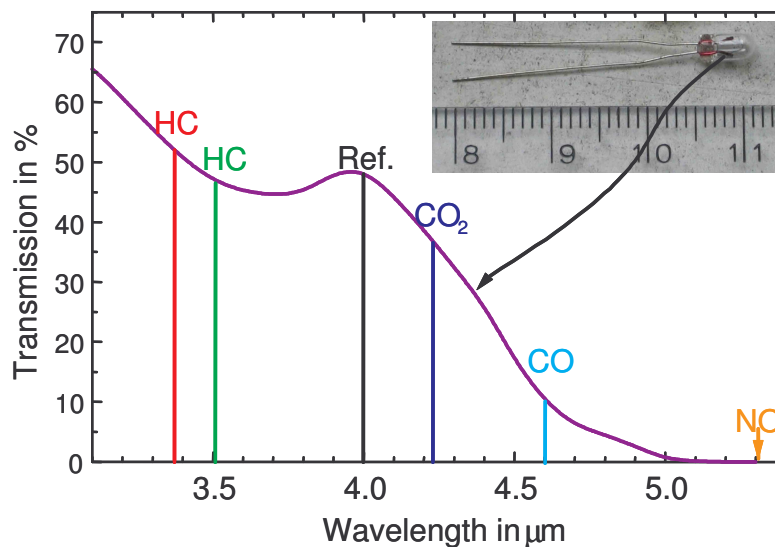

#### 6. Liability

Changes or modifications at the product which haven't influence to the performance and/or quality of the device haven't to be announced to the customers in advance. Customers are requested to consult with Heimann Sensor representatives before the use of Heimann Sensor products in special applications where failure or abnormal operation may directly affect human lives or cause physical injury or property damage. The company or their representatives will not be responsible for damage arising from such use without prior approval.