

e2v

MiCS-2710 NO₂ Sensor

This datasheet describes the use of the MiCS-2710. The package and the mode of operation illustrated in this document target the detection of nitrogen dioxide (NO₂).

FEATURES

- Low heater current
- Wide detection range
- High sensitivity
- Fast thermal response
- Miniature dimensions
- High resistance to shocks and vibrations

IMPORTANT PRECAUTIONS

Read the following instructions carefully before using the MiCS-2710 sensor described in this document to avoid erroneous readings and to prevent the device from permanent damage.

- The sensor must not be wave soldered without protection, or exposed to high concentrations of organic solvents, ammonia, or silicone vapours, to avoid poisoning the sensitive layer.
- Heating powers above the maximum rating of 120 mW can destroy the sensor due to overheating.
- This sensor is to be placed in a filtered package that protects it against any water or dust projection.
- For any additional questions, email enquiries@e2v.com or telephone +44 (0)1245 493493.

OPERATING MODE

The recommended mode of operation is a constant power mode. A heater power of $P_H = 43$ mW is applied. This causes the temperature of the sensing resistor (R_S) to reach about 220 °C.

Detection of the pollution gases is achieved by measuring the sensing resistor R_S during operation.

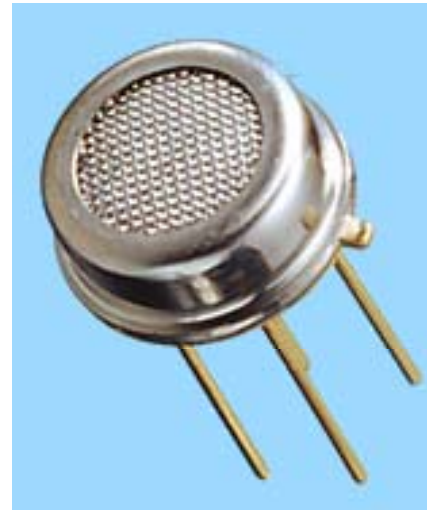

SENSOR RESPONSE

The sensor response to NO₂ in air is represented in Fig. 1.

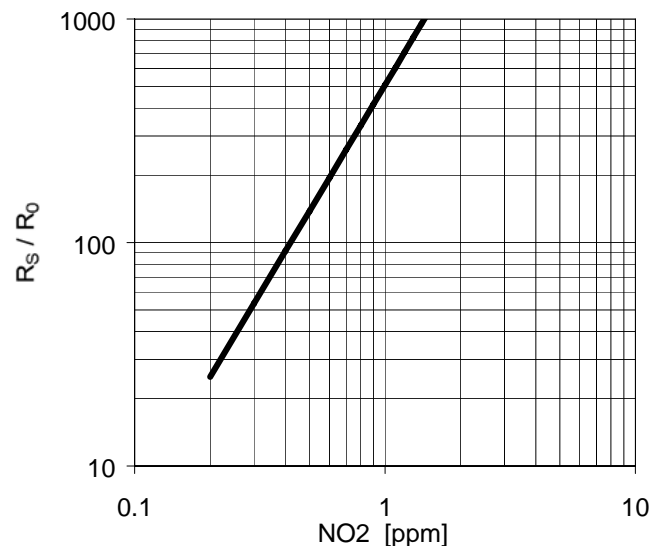

The sensor resistance R_S is normalised to the resistance under air (R_0).

Fig. 1: R_S/R_0 as a function of gas concentration at <5% RH and 25 °C.

Whilst e2v technologies has taken care to ensure the accuracy of the information contained herein it accepts no responsibility for the consequences of any use thereof and also reserves the right to change the specification of goods without notice. e2v technologies accepts no liability beyond the set out in its standard conditions of sale in respect of infringement of third party patents arising from the use of tubes or other devices in accordance with information contained herein.

e2v technologies (uk) limited, Waterhouse Lane, Chelmsford, Essex CM1 2QU United Kingdom Telephone: +44 (0)1245 493493 Facsimile: +44 (0)1245 492492

e-mail: enquiries@e2v.com Internet: www.e2v.com Holding Company: e2v technologies plc

e2v technologies inc. 4 Westchester Plaza, PO Box 1482, Elmsford, NY10523-1482 USA Telephone: (914) 592-6050 Facsimile: (914) 592-5148 e-mail: enquiries@e2vtechnologies.us

SUNSTAR自动化 <http://www.sensor-ic.com/> TEL: 0755-83376489 FAX:0755-83376182 E-MAIL: szss20@163.com

© e2v technologies (uk) limited 2008

A1A-MiCS-2710 Version 2, July 2008

104168

MEASUREMENT CIRCUIT

Fig. 2 shows the pin connections of the MiCS-2710 gas sensor. A simple circuit to measure the pollution level is proposed in Fig. 3. The heating voltage V_H is applied to pins 3 and 1. A load resistor R_L is connected in series with R_S to convert the resistance R_S to a voltage V_S between pins 2 and 4. R_S can then be calculated by the following expression:

$$R_S = R_L / (V_{CC} - V_S) \times V_S$$

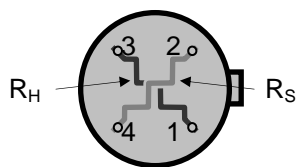

Pin	Connection
1	Heater ground
2	Sensor pin
3	Heater power
4	Sensor pin

Fig. 2: Equivalent circuit of MiCS-2710 (top view)

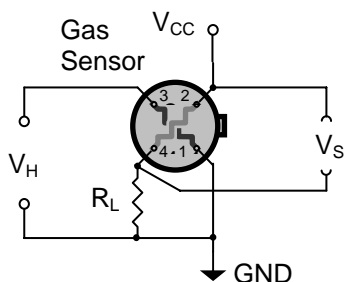

Fig. 3: Measurement circuit for pollution gas detection

ELECTRICAL SPECIFICATIONS

Maximum Ratings

Rating	Symbol	Value/Range	Unit
Maximum sensor supply voltage	V_{CC}	2.5	V
Maximum heater power dissipation	P_H	50	mW
Maximum sensor power dissipation	P_S	1	mW
Relative humidity range	R_H	5 – 95	%RH
Ambient operating temperature	T_{amb}	-30 – 85	°C
Storage temperature range	T_{sto}	-40 – 120	°C
Storage humidity range	RH_{sto}	5 – 95	%RH

Operating Conditions

Parameter	Symbol	Typ	Min	Max	Unit
Heating power	P_H	43	30	50	mW
Heating voltage	V_H	1.7	-	-	V
Heating current	I_H	26	-	-	mA
Heating resistance	R_H	66	59	73	Ω

Sensitivity Characteristics

Characteristic	Symbol	Typ	Min	Max	Unit
NO_2 detection range	FS		0.05	5	ppm
Sensing resistance in air (see note 1)	R_0	2.2	0.8	8	$k\Omega$
Sensitivity factor (see note 2)	S_R	55	6	100	-

Notes:

1. Sensing resistance in air (R_0) is measured under controlled ambient conditions, i.e. synthetic air at 23 ± 5 °C and $<5 \pm 5\%$ RH.
2. Sensitivity factor (S_R) is defined as R_S at 0.25 ppm of NO_2 divided by R_S in air. Test conditions are 23 ± 5 °C and $<5 \pm 5\%$ RH.

PACKAGE AND FILTER OUTLINE

(All dimensions nominal and in millimetres)

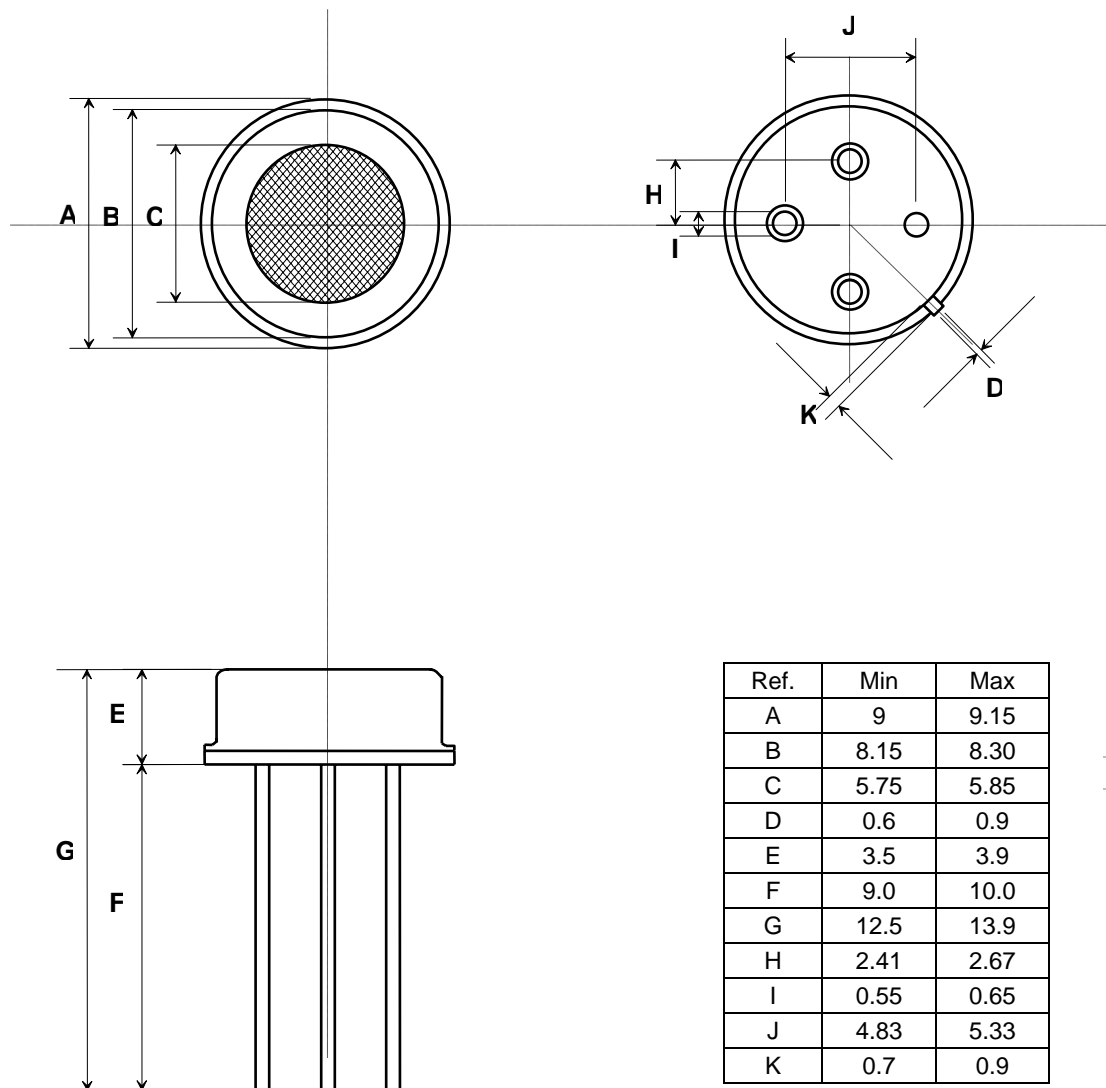

Ref.	Min	Max
A	9	9.15
B	8.15	8.30
C	5.75	5.85
D	0.6	0.9
E	3.5	3.9
F	9.0	10.0
G	12.5	13.9
H	2.41	2.67
I	0.55	0.65
J	4.83	5.33
K	0.7	0.9

Outline Notes:

1. A perfect pin alignment is not guaranteed.
2. The metallic mesh is optional.

e2v semiconductor gas sensors are well suited for leak detection and applications requiring limited accuracy. Their use for absolute gas concentration detection is more complicated because they typically require temperature compensation, calibration, and sometimes as well, humidity compensation. Their base resistance in clean air and their sensitivity can vary overtime depending on the environment they are in. This effect must be taken into account for any application development (117-5.0).