

e2v

MiCS-5121 CO/VOC Sensor

The MiCS-5121 is a general CO/VOC sensor. This sensor and the mode of operation are designed to measure reducing gases such as carbon monoxide (CO), hydrocarbons (HC), and volatile organic compounds (VOC).

FEATURES

- Low heater current
- Wide detection range
- High sensitivity
- Short pre-heating time
- Miniature dimensions
- High resistance to shocks and vibrations
- Protective cap

IMPORTANT PRECAUTIONS

Read the following instructions carefully before using the MiCS-5121 sensor described in this document to avoid erroneous readings and to prevent the device from permanent damage.

- The sensor must not be wave soldered without protection, or exposed to high concentrations of organic solvents, ammonia, or silicone vapours, to avoid poisoning the sensitive layer.
- Heater voltages above the specified maximum rating will destroy the sensor due to overheating.
- This sensor is to be placed in a filtered package that protects it against any water or dust projection.
- The use of ESD protection equipment to handle the sensor is strongly recommended.
- For any additional questions, email enquiries@e2v.com or telephone +44 (0)1245 493493.

OPERATING MODE

The recommended mode of operation is a constant power mode. A heater power of $P_H = 76$ mW is applied. This causes the temperature of the sensing resistor (R_S) to reach about 340 °C.

Detection of the pollution gases is achieved by measuring the sensing resistor R_S during operation.



SENSOR RESPONSE

The sensor response to CO in air is represented in Fig. 1. The sensor resistance R_S is normalised to the resistance under air (R_0).

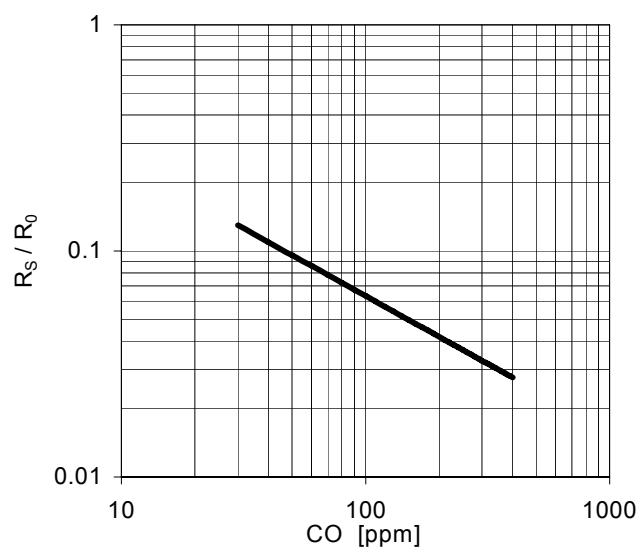

Fig. 1: R_S/R_0 as a function of CO concentration at 50% RH and 25 °C.

Whilst e2v technologies has taken care to ensure the accuracy of the information contained herein it accepts no responsibility for the consequences of any use thereof and also reserves the right to change the specification of goods without notice. e2v technologies accepts no liability beyond the set out in its standard conditions of sale in respect of infringement of third party patents arising from the use of tubes or other devices in accordance with information contained herein.

e2v technologies (uk) limited, Waterhouse Lane, Chelmsford, Essex CM1 2QU United Kingdom Telephone: +44 (0)1245 493493 Facsimile: +44 (0)1245 492492

e-mail: enquiries@e2v.com Internet: www.e2v.com Holding Company: e2v technologies plc

e2v technologies inc. 4 Westchester Plaza, PO Box 1482, Elmsford, NY10523-1482 USA Telephone: (914) 592-6050 Facsimile: (914) 592-5148 e-mail: enquiries@e2vtechnologies.us

SUNSTAR自动化 <http://www.sensor-ic.com/> TEL: 0755-83376489 FAX:0755-83376182 E-MAIL: szss20@163.com

© e2v technologies (uk) limited 2008

A1A-MiCS-5121 Version 2, July 2008

104168

MEASUREMENT CIRCUIT

Fig. 2 shows the pin connections of the MiCS-5121 gas sensor. A simple circuit to measure the pollution level is proposed in Fig. 3. The heating voltage V_H is applied to an $82\ \Omega$ resistor connected to pin 3 and pin 1 is connected to GND. This resistor is necessary to obtain the right heater power (2.4 V and 76 mW).

A load resistor R_L is connected in series with R_S to convert the resistance R_S to a voltage V_S between pins 2 and 4. R_S can then be calculated by the following expression:

$$R_S = R_L / (V_{CC} - V_S) \times V_S$$

R_L must be $820\ \Omega$ at the lowest in order not to damage the sensitive layer.

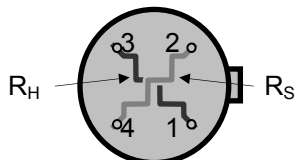

Pin	Connection
1	Heater ground
2	Sensor pin
3	Heater power
4	Sensor pin

Fig. 2: Equivalent circuit of MiCS-5121 (top view)

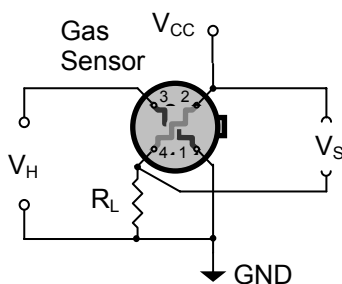

Fig. 3: Measurement circuit for pollution gas detection

ELECTRICAL SPECIFICATIONS

Maximum Ratings

Rating	Symbol	Value/Range	Unit
Maximum sensor supply voltage	V_{CC}	5 ± 0.1	V
Maximum heater power dissipation	P_H	88	mW
Maximum sensitive layer power dissipation	P_S	8	mW
Relative humidity range	R_H	5 – 95	%RH
Ambient operating temperature	T_{amb}	-30 – 85	°C
Storage temperature range	T_{sto}	-40 – 120	°C
Storage humidity range	RH_{sto}	5 – 95	%RH

Operating Conditions

Parameter	Symbol	Typ	Min	Max	Unit
Heating power	P_H	76	71	81	mW
Heating voltage	V_H	2.4	-	-	V
Heating current	I_H	32	-	-	mA
Heating resistance (see note 1)	R_H	74	66	82	Ω

Sensitivity Characteristics

Characteristic	Symbol	Typ	Min	Max	Unit
CO detection range	FS		1	1000	ppm
Sensing resistance in air (see note 2)	R_0	-	100	1500	k Ω
Sensitivity CO 60 ppm (see note 3)	S_R	-	5	50	-

Notes:

1. Resistance at heating power.
2. Sensing resistance in air (R_0) is measured under controlled ambient conditions, i.e. synthetic air at $23 \pm 5\ ^\circ\text{C}$ and $50 \pm 10\% \text{ RH}$.
3. Sensitivity CO 60 ppm is defined as R_S in air divided by R_S at 60 ppm of CO. Test conditions are $23 \pm 5\ ^\circ\text{C}$ and $50 \pm 10\% \text{ RH}$.

PACKAGE AND FILTER OUTLINE

(All dimensions nominal and in millimetres)

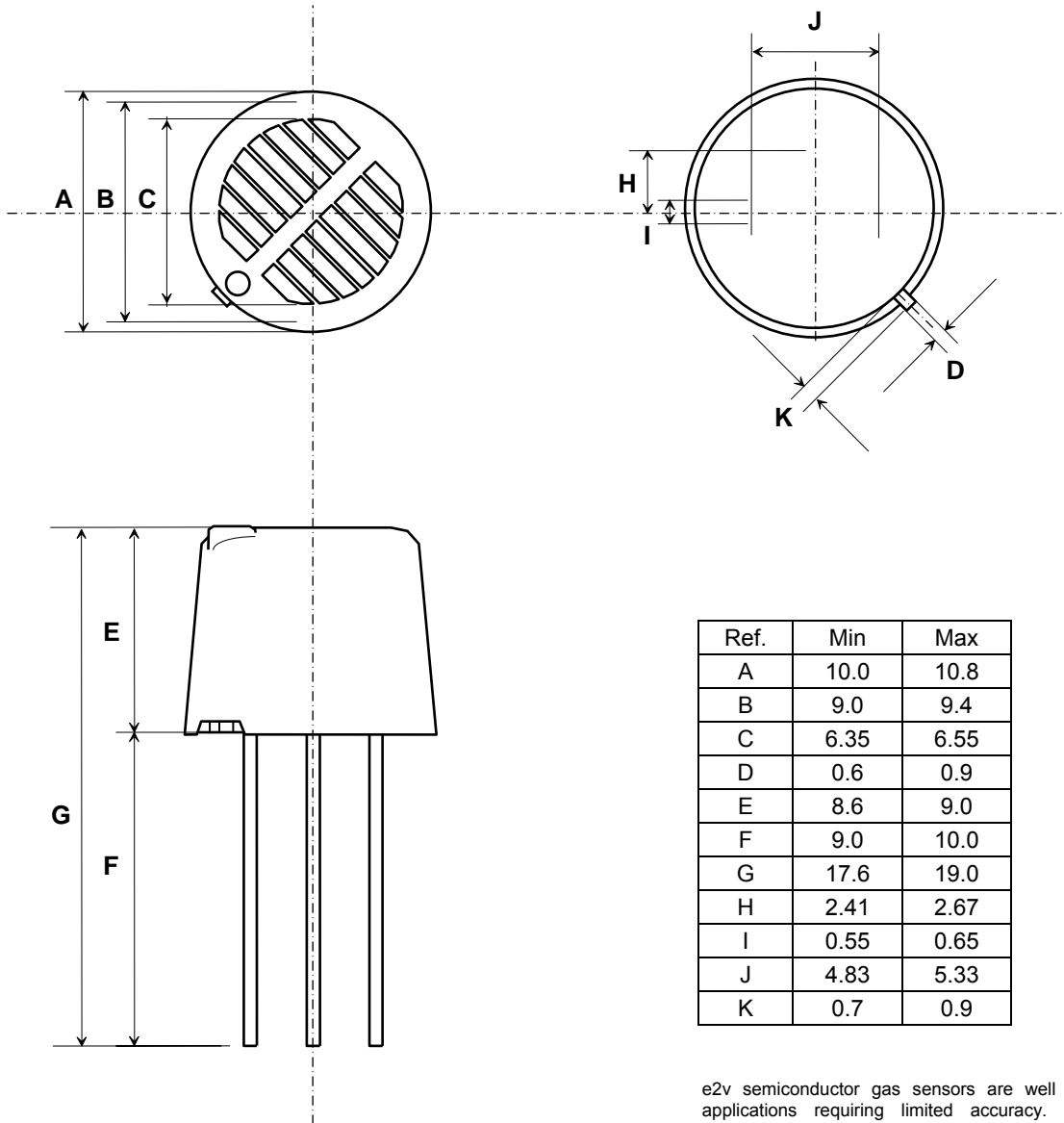

Ref.	Min	Max
A	10.0	10.8
B	9.0	9.4
C	6.35	6.55
D	0.6	0.9
E	8.6	9.0
F	9.0	10.0
G	17.6	19.0
H	2.41	2.67
I	0.55	0.65
J	4.83	5.33
K	0.7	0.9

e2v semiconductor gas sensors are well suited for leak detection and applications requiring limited accuracy. Their use for absolute gas concentration detection is more complicated because they typically require temperature compensation, calibration, and sometimes as well, humidity compensation. Their base resistance in clean air and their sensitivity can vary overtime depending on the environment they are in. This effect must be taken into account for any application development (1037-3.0).