

AG38AS-SMD-S

Broad Band (Al)GaN based UV photodiode $A = 0,076 \text{ mm}^2$

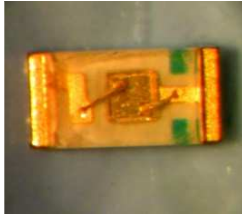

General Features



Properties of the AG38AS-SMD-S UV photodiode

- Broad Band UVA+UVB+UVC photodiode
- Active Area $A = 0,076 \text{ mm}^2$
- 1605 SMD ultra small housing Si window
- 10mW/cm^2 peak radiation results a current of approx. 700 nA

About the material (Aluminium)Gallium Nitride (Al)GaN

(Al)GaN is a new semiconductor material for visible blind UV photodiodes. By modification of the Al – to - Ga stoichiometry it is possible to produce photodiodes with different spectral behaviour. This allows to offer Photodiodes sensible for broad band UV (UVA+UVB+UVC), for UVB-only and for UVC only without using a filter.

Specifications

Parameter	Symbol	Value	Unit
Maximum Ratings			
Operating Temperature Range	T_{opt}	-25 ... +70	°C
Storage Temperature Range	T_{stor}	0 ... +100	°C
Soldering Temperature (3s)	T_{sold}	260	°C
Reverse voltage	V_{Rmax}	5	V
General Characteristics (T=25°C)			
Active Area	A	0,076	mm^2
Dark current (1V reverse bias)	I_{d}	100	fA
Capacitance	C	24	pF
Short circuit (10mW/cm^2 at peak)	I_0	700	nA
Temperature coefficient	Tc	<-0,3	%/K
Spectral Characteristics (T=25°C)			
Max. spectral sensitivity	S_{max}	0,130	AW^{-1}
Wavelength of max. spectral sens.	λ_{max}	350	nm
Sensitivity range ($S=0,1 \cdot S_{\text{max}}$)	-	220 ... 370	nm
Visible blindness ($S_{\text{max}} / S_{>400\text{nm}}$)	VB	$>10^2$	-

AG38AS-SMD-S

Broad Band (Al)GaN based UV photodiode $A = 0,076 \text{ mm}^2$



Spectral Response

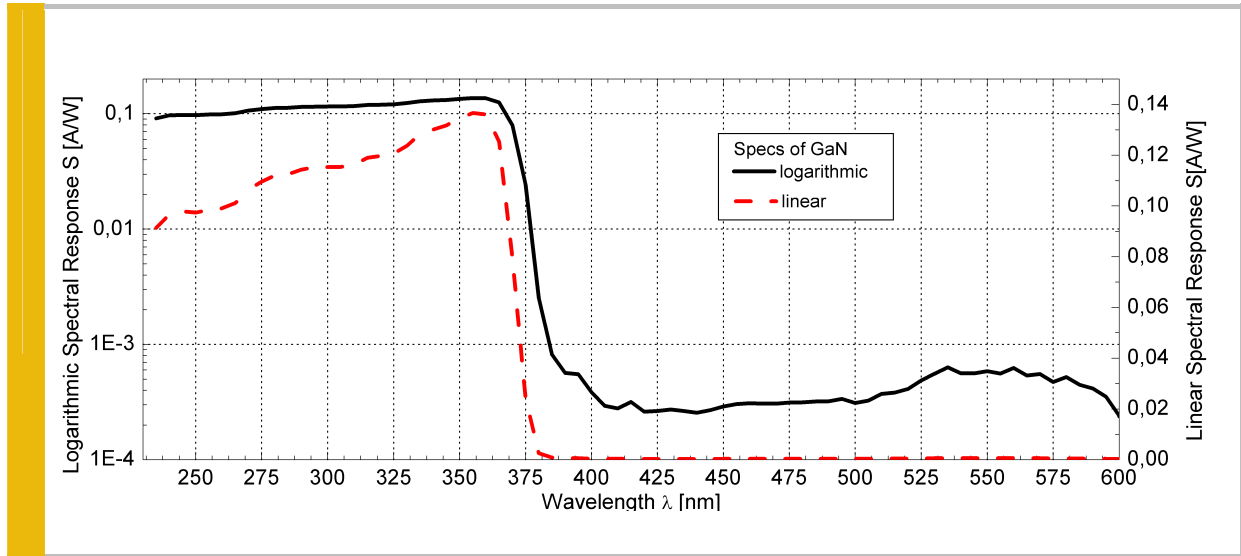

Circuit

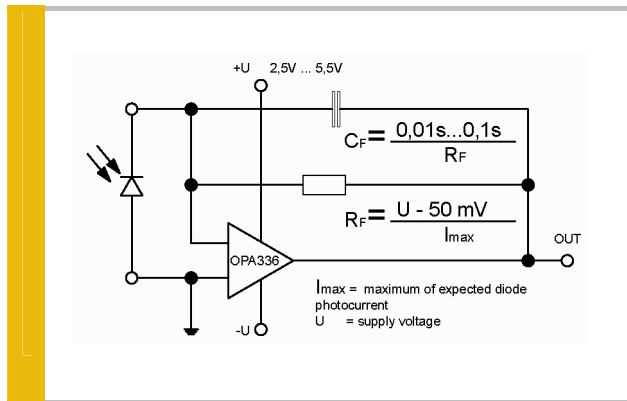

Viewing Angle

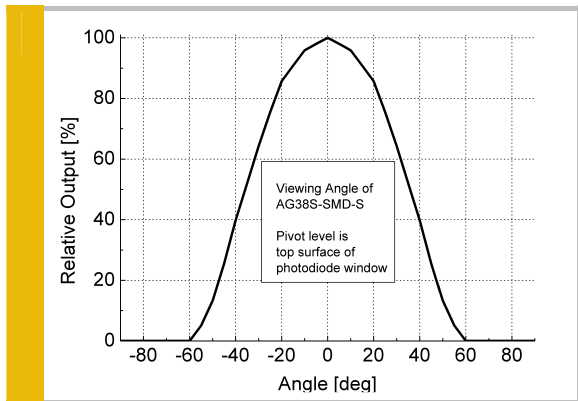

Drawing

