

DIGIBOARD

Transimpedance Amplifier Board



Description

Most applications of photodiodes and especially those in the ultraviolet wavelength range require special amplifiers because of the small photocurrents. Although the uv-sensors of **sglux** provide large active areas you mostly may consider using an amplifier.

To support your application development we provide you this completely new photodiode amplifier board. Based on our successful **Multifunctional 2-Channel Amplifier Board** we included additional features: one analog channel with adjustable Schmitt-Trigger (ST) and a Current-to-Frequency converter (CFC) channel.

The CFC clearly simplifies the integration of our photodiodes into digital- and microprocessor based designs.

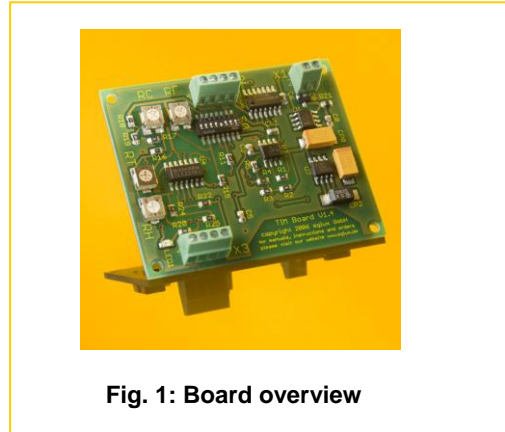

Fig. 1: Board overview

Features

- wide single supply voltage range 5.0 V ... 18.0 V with surge and polarity protection
- low power consumption (< 50 mW @ 5 V)
- analog transimpedance amplifier channel with:
 - adjustable gain in the range 10^5 ... 10^7 V/A with fine tuning option
 - Schmitt-Trigger stage with adjustable switching point and adjustable Hysteresis
 - LED for easy adjustment of the Schmitt-Trigger
- Current-to-Frequency converter with:
 - 2 measurement ranges giving high dynamic range
 - standard CMOS compatible digital output

Important Notice

Please consider any possible action to protect the sensitive devices on the board against electrostatic discharge (ESD). Not to do so voids warranty.

DIGIBOARD

Transimpedance Amplifier Board



Getting Started

Power Supply

This board requires a single DC voltage supply from 5 V ... 18 V to be connected as shown in figure 2. In general a simple filtered DC source is sufficient.

But for ultra low noise and high gain measurements we recommend using batteries or carefully selected power supply units.

The Board is protected against wrong polarity of the power supply. The surge protection device (AVX TransGuard VC080518) has a breakdown voltage of about 23 V and is capable of handling Pulses with 0.1 J / 10 μ s.

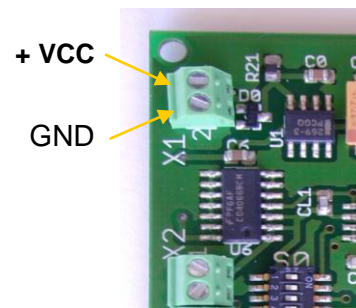

Fig. 2: Power supply connection

Current-to-Frequency Converter

The input and output connections for this Channel are shown in figure 3. The anode of the photodiode must be connected to the input terminal and the cathode to GND.

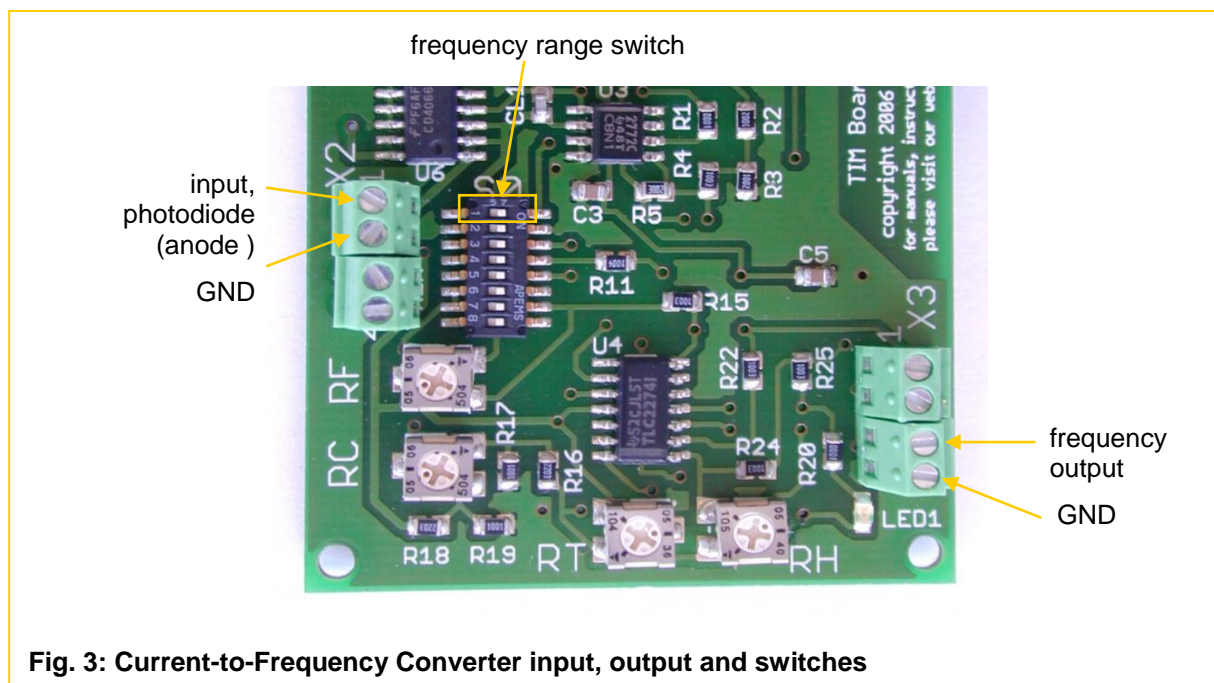

Fig. 3: Current-to-Frequency Converter input, output and switches

If there appears no pulse signal on the output the polarity of the photodiode may be wrong. Also check that your equipment is able of recognising pulses as short as 1 μ s. Especially with older analog oscilloscopes and under artificial illumination it can be tricky to trigger these pulses because the output frequency may vary with the double of the mains frequency.

The measurement range can be selected by switch 1 as shown in the following table. One can calculate the output frequency by multiplying the photocurrent with the given conversion factor.

Switch 1	Mode	Conversion factor
1 = OFF	high frequency / low current	$\sim 3.3 \square 10^9 \text{ Hz / A}$
1 = ON	low frequency / high current	$\sim 3.0 \square 10^8 \text{ Hz / A}$

In both ranges the useful frequencies range from 0.1 Hz up to about 40 kHz giving a dynamic range of 112 dB. Above 40 kHz the linearity error increases steeply as shown in figure 4 due to the influence of the fixed output pulse duration on the total integration cycle length.

In programmable systems the linearity error can be corrected by using a matched lookup table. In this case frequencies up to 500 kHz can be used and thus the total dynamic range increases by two orders of magnitude.

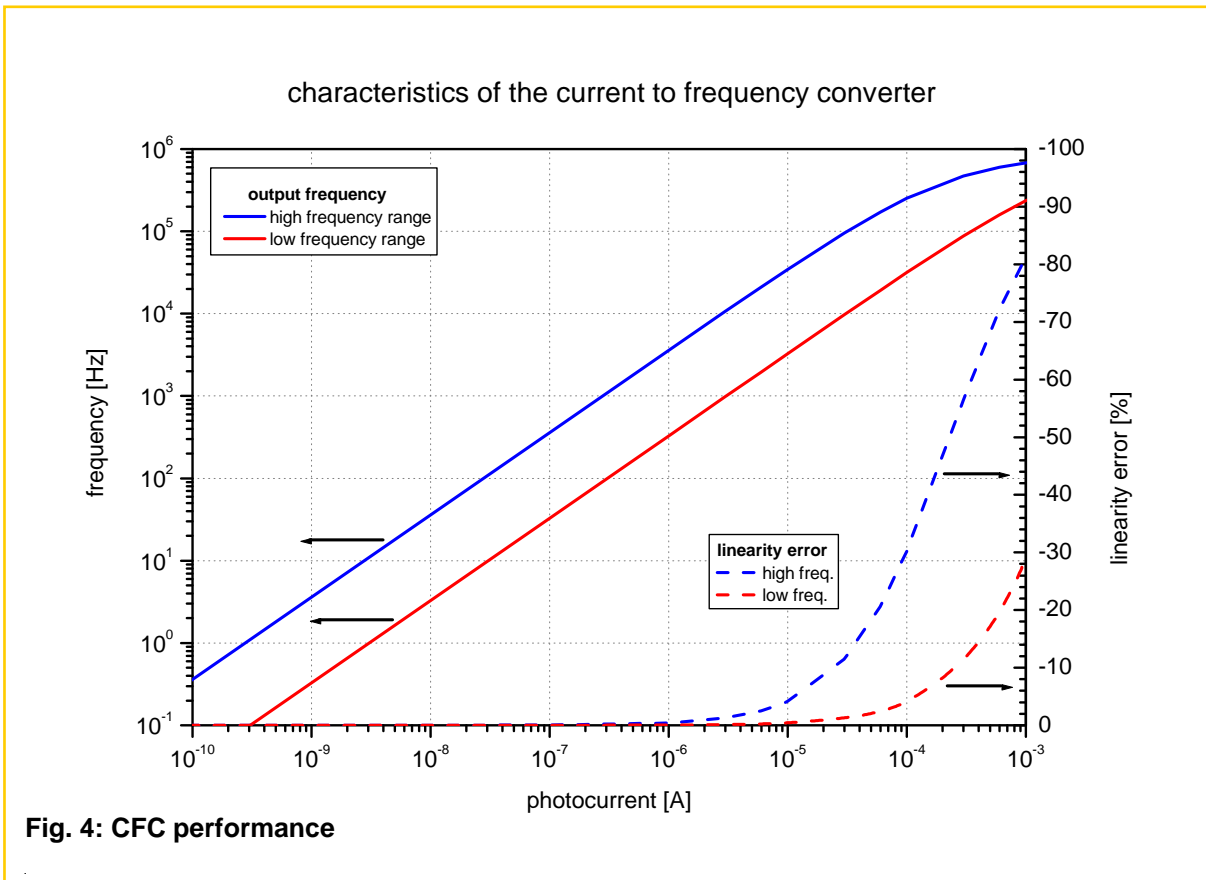

Fig. 4: CFC performance

Hint: If you require different conversion factors the load capacitors CL1 and CL2 have to be changed. CL1 is solely active with switch 1 opened. Closing switch 1 puts both capacitors in parallel and the active load capacitance equals their sum. We are happy to assist you with that or to deliver boards adapted to your application.

Analog Amplifier Channel

Amplifier stage

This channel is completely independent of the CFC and works fully bipolar. Please refer to figure 5 for the appropriate connections and controls.

If you connect the anode of the photodiode to the input pin the output voltage is negative and vice versa.

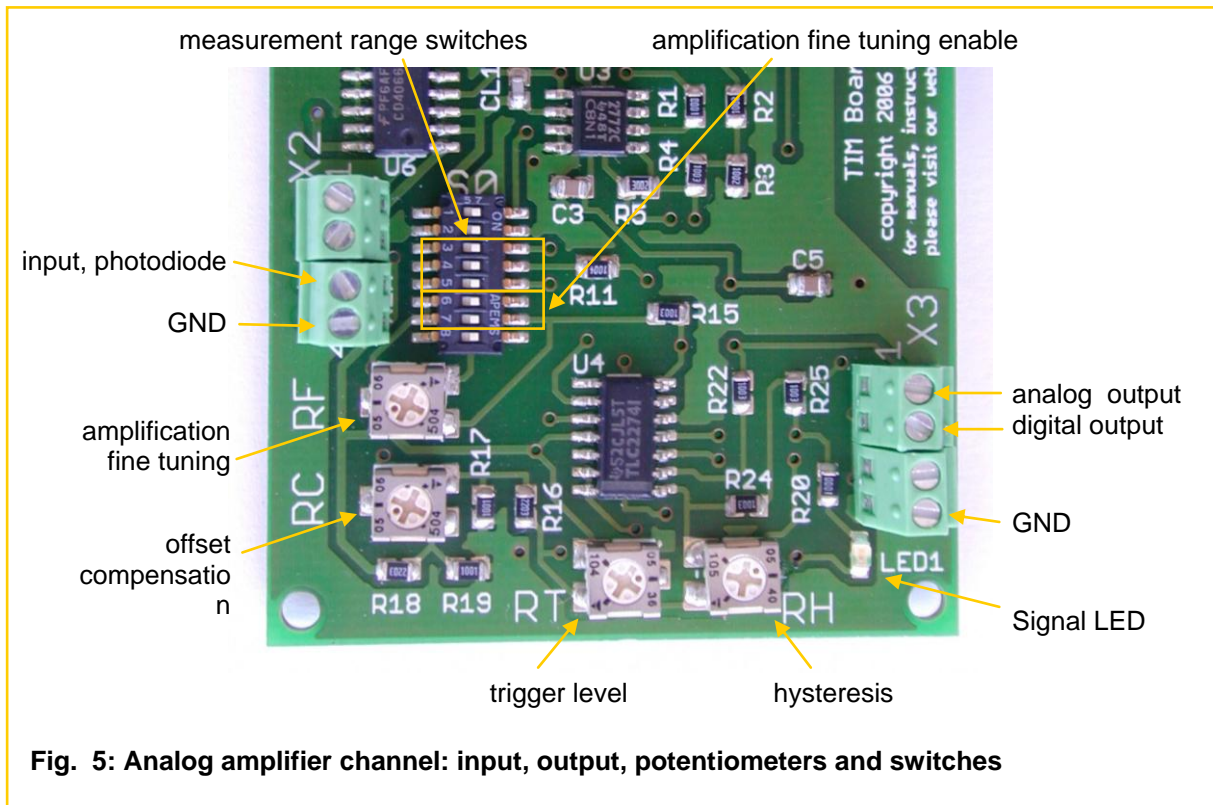

Fig. 5: Analog amplifier channel: input, output, potentiometers and switches

For basic operation close (ON) one of the switches 3, 4, 5 and both switches 6 and 7. The amplification can be selected as follows:

Switches 3,4,5	Amplification
3 = ON 4 = OFF 5 = OFF	10^7 V/A
3 = OFF 4 = ON 5 = OFF	10^6 V/A
3 = OFF 4 = OFF 5 = ON	10^5 V/A

DIGIBOARD

Transimpedance Amplifier Board



To activate amplification fine tuning you must open both switches 6 and 7 (OFF). Now you can adjust the total amplification with potentiometer “RF” by a factor in the range 0.5 ... 1.5.

Switches 6,7	Amplification fine tuning
6 = OFF 7 = OFF	enabled
6 = ON 7 = ON	disabled

Example: You choose 10^6 V/A and fine tuning. Now with “RF” you can trim the amplification in the range $5 \cdot 10^5$ V/A to $1.5 \cdot 10^6$ V/A.

The maximum analog output voltage is approx. ± 3.0 V and the output current must not exceed 1 mA. Please note that the amplifier is fast enough to resolve intensity modulation of the doubled mains frequency as normally found when using fluorescent lamps.

The input offset can be compensated by this procedure:

1. select amplification
2. connect the (darkened) photodiode
3. switch power on
4. adjust ‘RC’ potentiometer until the analog output voltage is as small as possible (typically below 10 mV)

Schmitt-Trigger

The analog output voltage is internally connected to the Schmitt-Trigger. The switching point can be adjusted by potentiometer “RT” within the range +3 V (left stop) ... -3 V (right stop).

The Hysteresis is adjustable by potentiometer “RH” from 0.05 V (left stop) to approx. 1.5 V (center position). It doesn’t make sense to use the range from beyond the middle to the right stop because with such large hysteresis the function is unstable.

The logical state of the Schmitt-trigger output is displayed by the red LED. The LED is on if the output is logically HIGH (~ 3 V).

Special feature:

- if the analog output voltage is positive: the Schmitt-Trigger output goes HIGH if the analog output voltage exceeds the switching point.
- if the analog output voltage is negative: the Schmitt-Trigger output goes LOW if the analog output voltage exceeds the switching point.

Thus it is possible to realise either overshoot or undershoot detection with the same device by changing the polarity of the photodiode!

Physical Dimensions

All dimensions are shown in millimeters.

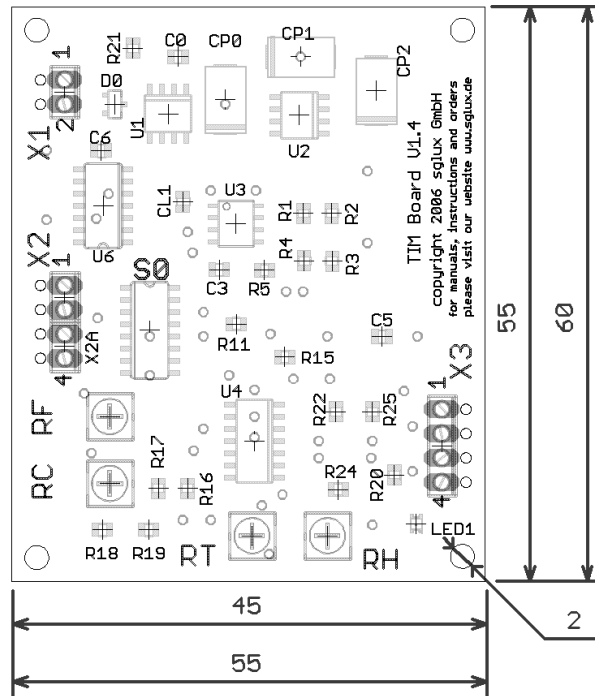

Absolute Maximum Ratings

Exceeding these limits may decrease lifetime or destroy the board or parts of it immediately.

Parameter	Unit	Value
Operation Temperature range *	°C	0 ... +70
Storage Temperature range *	°C	-25 ... +85
Supply voltage	V	+18.5
Output current (digital output)	mA	0.5
Output current (analog output)	mA	10

*in non condensing environment only

DIGIBOARD

Transimpedance Amplifier Board



Electrical Characteristics (at 25°C unless otherwise noted, default jumper settings)

General

Parameter	Unit	min	Value typ	max
Supply voltage	V	5	12	18
Power dissipation (at 5 V supply voltage, depends on load and switching frequency)	mW		50	

Analog channel

Parameter	Unit	min	Value typ	max
Fixed transimpedance gain (gain setting by switches 3,4,5) low medium high	V/A	0.98 □ 10 ⁵ 0.98 □ 10 ⁶ 0.90 □ 10 ⁷	10 ⁵ 10 ⁶ 10 ⁷	1.02 □ 10 ⁵ 1.02 □ 10 ⁶ 1.10 □ 10 ⁷
Variable transimpedance gain factor range*		0.7 – 1.3	0.5 – 1.5	0.3 – 1.7
Input current	A			□ 30 □ 10 ⁻⁶
Maximum output voltage (in both polarities)	V	□ 2.6	□ 2.9	□ 3.3
Output offset voltage (with optimal compensation)	mV		< □ 5	□ 10

* if fine tuning selected by closing switches 6 and 7 total gain derived by multiplying fixed gain with variable gain factor

Digital channel

Parameter	Unit	min	Value typ	max
Output voltage LOW*	V	0	0.05	0.1
Output voltage HIGH*	V	2.8	3.1	3.3
Frequency output pulse length FWHM (levels above)	μs	1	1.2	2
Input current	A	~ 10 ⁻¹⁰		~ 10 ⁻⁴
Conversion rate low frequency mode high frequency mode	Hz / A	2.8 □ 10 ⁸ 3.1 □ 10 ⁹	3.0 □ 10 ⁸ 3.3 □ 10 ⁹	3.2 □ 10 ⁸ 3.5 □ 10 ⁹
Conversion rate temperature dependence	1 / K		□ 3 □ 10 ⁻⁵	

DIGIBOARD

Transimpedance Amplifier Board



Linearity error, high frequency mode				
@ 10 kHz			1	
@ 40 kHz	%		5.2	
@ 100 kHz			12	
Linearity error, low frequency mode				
@ 10 kHz			1	
@ 40 kHz	%		5.5	
@ 100 kHz			13	

** for the frequency output as well as for the Schmitt-Trigger output*