

## Product Datasheet

# Laser Gas Detection OEM Modules LGD F200-A NH3

## 1 General description

**Axetris** is offering Laser Gas Detection (LGD) modules with exceptional advantages and value for the customer. Tunable Diode Laser Spectrometry (TDLS), enhanced by proprietary technology, is used for the measurement of CO<sub>2</sub>, NH<sub>3</sub>, CH<sub>4</sub>, HCl, (H<sub>2</sub>O). The modules are designed for integration by Original Equipment Manufacturers (OEMs), active in the field of gas detection and monitoring in diverse industries.

The **LGD F200** series is based on a contactless, near-infrared absorption measurement of the target gas. The systems are self-contained, ready-to-use OEM modules, using a flow-through cell set-up for extractive measurements. The LGD F200 (H) version features cell heating up to 190°C for hot gas measurements in process control and environmental compliance related applications.

The system has micro-processor-driven read-out electronics and digital and/or analog data outputs for industry-standard connectivity. Proprietary electronic lock-in technology allows separating gas absorption information from electro-optical system information, eliminating the need for a physical reference channel and providing continuous sensor status monitoring.

Low maintenance operation and long life time provide customers with exceptionally low cost-of-ownership and make the LGD F200 the ideal instrument for your OEM applications.

### Main applications

- Process control:  
SCR, incineration & combustion processes
- Emission monitoring:  
Power generation, engine development, waste incineration furnaces, ...
- Environmental monitoring:  
Landfill & green-house gases, livestock, ...
- Chemical engineering:  
Production control & monitoring ...
- Safety:  
Leak detection, refrigeration, toxic gases, .
- Climate control & monitoring:  
Livestock, climate chambers & rooms, ..



### Key features

- Made for easy integration by OEMs
- Optical, contact-less measurement
- Accurate laser-diode electro-optics
- High selectivity
- Fast response
- Self-contained
- Continuous sensor status monitoring
- Low maintenance
- Low cost-of-ownership
- 10-30V power supply
- Digital and analog output

## 2 Hardware specifications

### 2.1 Gas detection specifications

**Important: Reference conditions, external: 20 °C, 1013 hPa, 45% r.H.**

Parameter	Unit	Value / Range
Gas	-	NH <sub>3</sub>
Principle of detection	-	Tunable Diode Laser Spectrometry (TDLS)
Measuring range	ppm	0 – 100 calibration to full scale (FS) range, standard is 100 ppm, for safety reasons max. calibration to 100 ppm (linearity up to 500 ppm, no warranty of precision)
Accuracy <sup>1</sup>	-	± 2% full scale reading depending on integration stability (temperature & pressure)
Precision <sup>2</sup> 2σ	ppm	1.0 @ 1 s integration 0.4 @ 10 s integration
Zero drift <sup>3</sup> over 2 h period	-	within accuracy
Span drift <sup>4</sup> over 8 h period	-	within accuracy
Max. error on temp. comp.	% of reading/°C	< 0.1
Linearity & Repeatability	-	included in the accuracy
Cross talk/interference	-	Gas matrix and application dependent
Displayed resolution	ppm	0.1 (negative values can also be displayed)
Refresh rate	s	1 (integration time can be selected, max. 120 s) up to 2 s in case no target gas is present
T <sub>90</sub> time	s	2 (at gas flow rate of 3 L/min)
Ambient temp. compensat.	°C	-30 ... 65 (as narrow as possible, application defined)
Meas. gas max. humidity	% abs. H <sub>2</sub> O	application dependent, needs calibration
Input for external parameter compensation	-	pressure, temperature or matrix gas concentration (optional customization)

<sup>1</sup> **Accuracy:** The accuracy (or global incertitude) is defined according to the standard EN 45544-1:1999 by a combination of the systematic error (deviation between the average measured value and the real concentration) and the precision. For a given (known) reference concentration, the accuracy is defined as the difference between the mean response during a 5 minute time interval and the reference value plus the precision at reference conditions. This value thus contains all systematic errors, e.g. calibration set up differences, calibration gas variation, etc. System performance is accuracy-limited when the unit is exposed to temperature variations.

<sup>2</sup> **Precision:** The precision is defined as 2 times the standard deviation  $\sigma$  of a 5 minute measurement at stable reference conditions. System performance is precision-limited (not accuracy-limited) when the system temperature is stable.

<sup>3</sup> **The zero-response** is defined as the mean response including noise to a zero-gas during a 30 s time interval.

<sup>4</sup> **The analyzer span** is defined as the difference between the span-response and the zero-response. The span-response is defined as the mean response including noise to a span gas during a 30-second time interval.

## 2.2 Environmental conditions

Parameter	Unit	Value / Range
Usage	-	Interior use
Maximum operating temperature range	°C	-30 ... 65
Operating humidity	% r.H.	0 ... 99, non-condensing
Operating pressure	mbar	800 ... 1100
Storage temperature	°C	-40 ... 80
Storage humidity	% r.H.	0 ... 99, non-condensing

## 2.3 Mechanical characteristics

Parameter	Unit	Value / Range
Measurement cell	-	Flow-through set-up
Standard cell length	mm	200
Std. optical path length	mm	400
Standard cell volume	mL	15
Maximum measurement gas flow (Minimum)	mL / min	5'000 (1'000); std. calibration carried out at 3'000
Dimensions housing, ambient (A) version:	mm <sup>3</sup>	340 x 107 x 78
Approx. weight, ambient (A) version	kg	1.9
Inlet / outlet connectors, measurement gas	mm	6 O.D., Swagelok
Inlet / outlet connectors, purge gas (optional)	mm	6 O.D., push-in fitting

## 2.4 Electrical characteristics

Parameter	Unit	Value / Range
Voltage supply DC		
Min. / Max. rating	V	10 ... 30 (max. ripple $\pm$ 100mV, max. current 1A, no inrush current limitation)
System power consumpt.	W	< 2
Start-up time	s	30

## 2.5 Communication interface

Parameter	Unit	Value / Range
Digital I/O		
	RS232	dig. Protocol available; standard
	I <sup>2</sup> C	dig. On request only
Analog output		
	Current output	mA 4...20, 12-bit resolution (on 0 ... 25 mA); standard
	Voltage output	V 0...5, 12-bit resolution; on request upon order
Alarm levels	-	Customer definable

## 3 Connector assignments

### 3.1 System Power / User interface connector assignments

Figure 1: Head view electronics housing.  
System Power / User interface terminal connector assignment.

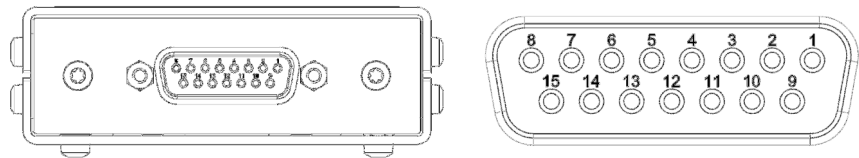

Connector assignment:

	Pin	Name	Description
Power	1	POWER IN	Power supply 10 ... 30V
Supply	2	GND IN	Power supply ground
	3	SHIELD	DB 15 Connector - Housing
Digital	6	GND*	Ground serial communication
Interfaces	7	RS232 TX	UART serial communication
	8	RS232 RX	UART serial communication
	14	I <sup>2</sup> C CLK	I <sup>2</sup> C serial communication
	15	I <sup>2</sup> C SDA	I <sup>2</sup> C serial communication
Digital Alarms	4	ALARM 1	Customer defined, e.g.: On/Off signal, relay control, hardware watchdog, etc.
	5	ALARM 2	Customer defined, e.g.: On/Off signal, relay control, hardware watchdog, etc.
	11	ALARM 3	Customer defined, e.g.: On/Off signal, relay control, hardware watchdog, etc.
	12	VCC RELAY	Relay power supply (internally connected to Pin 1)
	13	GND*	Ground, digital alarms
Analog	9	ALANALOG GND*	Analog ground
Interface	10	ALANALOG OUT	Analog output Can be set as output voltage (0-5V) or output current (4-20mA)

\* same potential

## 4 Mechanical dimensions

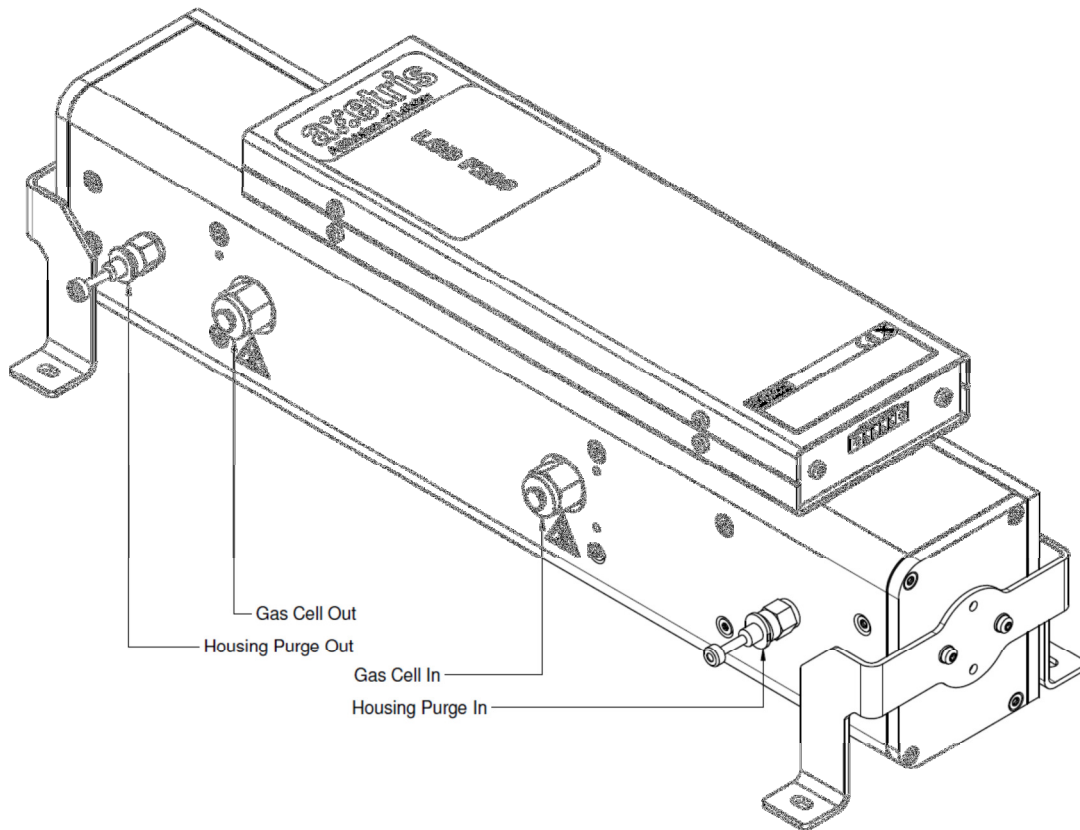

Figure 2: General view of the LGD F200 H sensor.

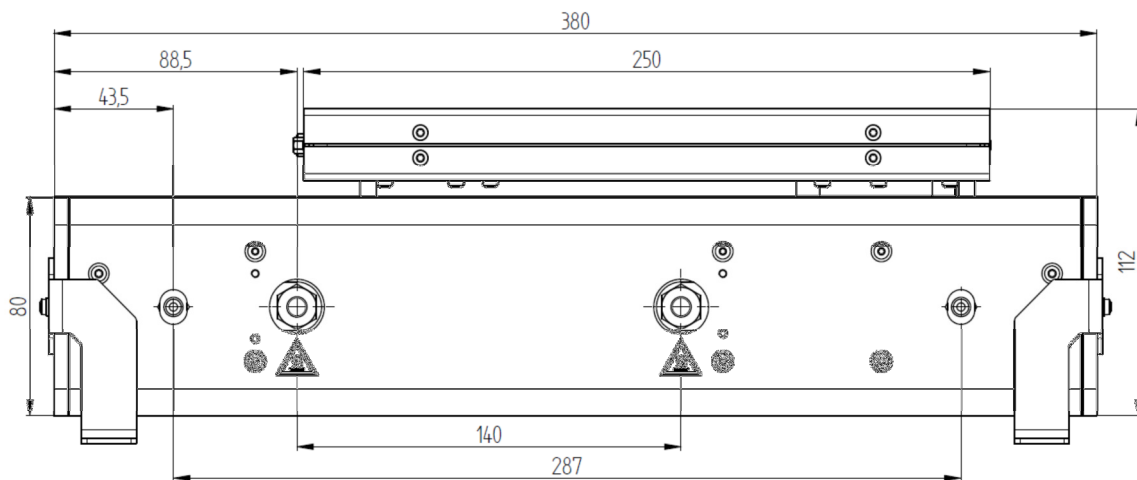

Figure 3: Side view, with gas connectors. Dimensions in mm.

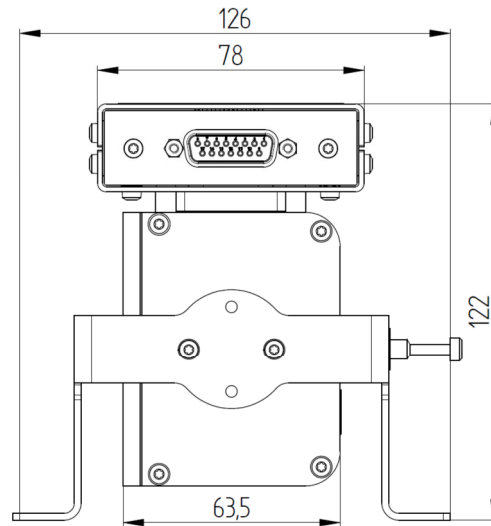

Figure 4: Front view. Dimensions in mm.

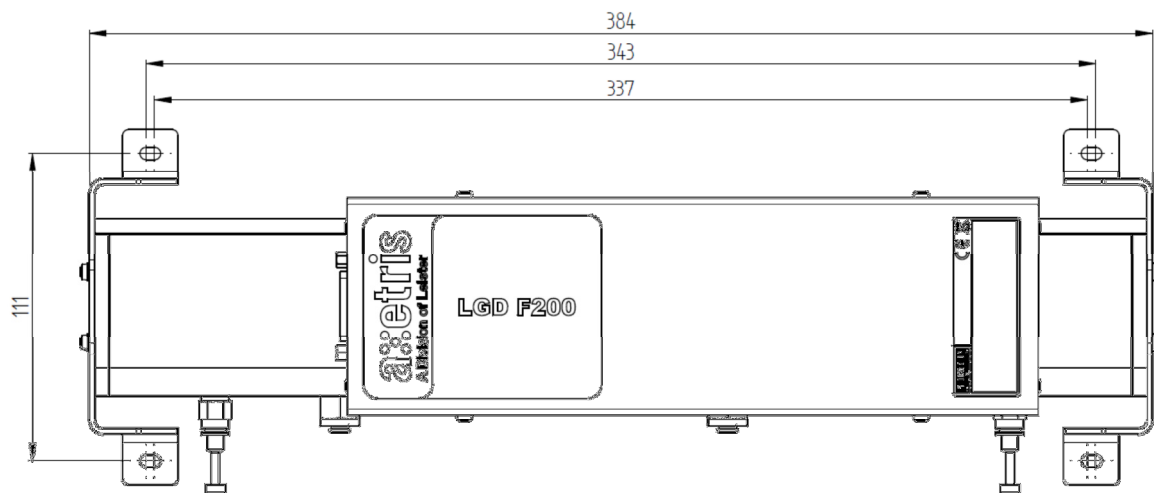

Figure 5: Top view. Dimensions in mm.

## 5 Mechanical interface

The module is equipped at its front & back end with mounting brackets. The brackets can be fixed in four different 90° rotated positions. To increase vibration and shock protection Axetris provides rubber fixations that can be mounted between the brackets and the instrument mounting location.

## 6 Gas Conditioning and filtering

Due to the multitude of applications for the LGD, gas conditioning and filtering has to be carried out by the integrating Original Equipment Manufacturer (OEM). The following points are crucial in order to operate the unit correctly and to achieve long operating life-times:

- The temperature of the incoming sample gas has to be at the same temperature as the temperature of the measurement cell. Deviations will create a decrease in accuracy. This is particularly important for the (H) version for hot-gas measurements, where heated sample lines are necessary (and are the industry standard).
- Performance of the unit, its service intervals, as well as its life-time can be influenced by the employed filter technology. Commercial solutions from industry specific manufacturers are available on the market.

## 7 Certifications

Type	Standard / Regulation	Limits
European Conformity:	CE	
Low voltage	2006/95/EG	
EMC compatibility	2004/108/EG	
Safety of laboratory products	EN/IEC 61010	
Safety of laser products	EN/IEC 60825-1	
EMC	EN/IEC 61326-1 Immunity	EMC: Electrical equipment for measurement, control and laboratory use A-version: Industrial standard (10V/m)
Shock	EN60068-2-27	50 m/s <sup>2</sup> , 50ms, half sinus, 11ms, max acceleration 15g, 50 cycles
Vibration	EN60068-2-6	5 ... 50Hz, amplitude 0.35mm, resp. 50m/s <sup>2</sup> Crossover frequency 25Hz, 1 octave /min, 2h per orientation (total 20 Frequency cycle)
Electronics conformity	RoHS / WEEE	



## 8 Factory calibration

The LGD F200 are factory calibrated to customer specifications. In some cases a more specific customer calibration might be needed where complicated measurement conditions or complex gas matrices are present. In this case the customer might proceed to perform his own calibration of the system.

Systematic differences between the factory calibration set-up and the customer measurement/calibration set-up can be handled with an off-set and gain adjustment of the sensor.

## 9 Installation instructions

Questions related to the user interface, start-up, installation and use of the unit can be found in the LGD F200 User manual.

## 10 Electromagnetic compatibility

The LGD F200 module is a compact self-contained instrument, which is specially designed for system integration. In the configuration provided by Axetris, it fulfils the EMC requirements as given in the above chapter on certifications.

## 11 Caution



### Product damage

- Read all instructions carefully before using the device.
- The LGD F200 laser gas detection modules are calibrated for a particular gas and concentration range. Do not use the sensor outside of its specifications
- The sensor is not suited for measuring gases with a dust load. The incoming measurement gas must be conditioned in order to avoid dust and condensation of liquid in the sensor. Gas loaded with particles or other substances can eventually contaminate the cell and make it necessary to service the instrument.

- The appliance must not be used in damp or wet surroundings.
- Use only accessories that are indicated in the instructions for use or are recommended by the manufacturer.
- Failure to comply with these instructions could result in product damage.



### Danger of life

- The sensor must not be used with flammable or explosive gases or mixtures.
- Unprofessional gas handling can cause injury or death. The use of gas detection modules should only be performed by qualified personnel.
- Do not use this product as safety or emergency stop device or in any other application where failure of the product could result in personal injury or death.

## 12 Important notice / Disclaimer

The information furnished by Axetris is believed to be correct and accurate. However, Axetris shall not be held liable to recipient or any third party of any damages, including but not limited to personal injury, property damage, loss of profits, loss of use, interrupt of business or indirect, special incidental or consequential damages, of any kind, in connection with or arising out of the furnishing, performance or use of technical data herein. No obligation or liability to recipient or any third party shall arise or flow out of Axetris rendering of technical or other services.

While due caution has been exercised in the production of this document, possible errors and omissions are unintentional.

## 13 Axetris Certifications

Axetris is an ISO 9001 : 2008 certified company.

