

Model 1246

Wheel Torque Sensor

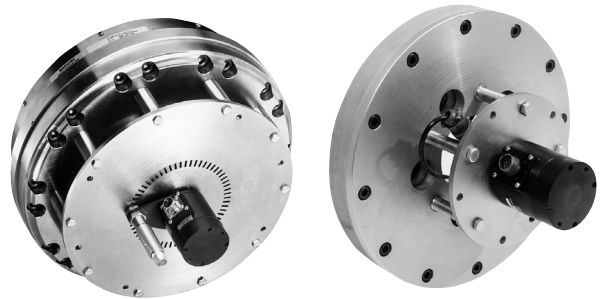

DESCRIPTION

The automobile wheel torque sensor is designed to be bolted to the brake drum or spindle of a car or truck in place of the regular wheel. The wheel is then bolted to the torque sensor. This moves the wheel outward approximately 1-1/2 inches from its original location. A slip ring or rotary transformer assembly is provided to connect the torque sensor to an instrument in the vehicle.

The sensor is normally furnished with one adapter plate for one given stud pattern. Also, on some models, a dc tachometer or 60-tooth gear and magnetic pickup generator can be supplied which provides a signal proportional to wheel speed. Standard capacity ranges of 20K, 30K, and 36K in-lb, others available upon request.

FEATURES

- 20K in-lb, 30K in-lb, and 36K in-lb capacities
- 0.25 % non-linearity and hysteresis
- Speed sensor (optional)
- "At-the-source" torque measurement
- Large selection of capacities available
- Special custom configurations available

Model 1246

Wheel Torque Sensor

PERFORMANCE SPECIFICATIONS

Characteristic	Measure
Torque range 1246	20K, 30K, 36K lb-in
Non-linearity	±0.25 % of rated output
Hysteresis	±0.25 % of rated output
Repeatability	±0.1 % of rated output
Output @ rated capacity	±1.5 mV/V (nominal)

ENVIRONMENTAL SPECIFICATIONS

Characteristic	Measure
Temperature, operating	-29 °C to 93 °C [-20 °F to 200 °F]
Temperature, compensated	21 °C to 77 °C [70 °F to 170 °F]
Temperature effect, zero	±0.002 % of rated output/°F
Temperature effect, output	±0.002 % of reading/°F

ELECTRICAL SPECIFICATIONS

Characteristic	Measure
Excitation (maximum)	20 Vdc or Vac RMS
Insulation resistance	> 5000 mOhm @ 50 Vdc
Bridge resistance	700 ohm (nominal)
Number of bridges	1
Zero balance	±5.0 % of rated output

MECHANICAL SPECIFICATIONS

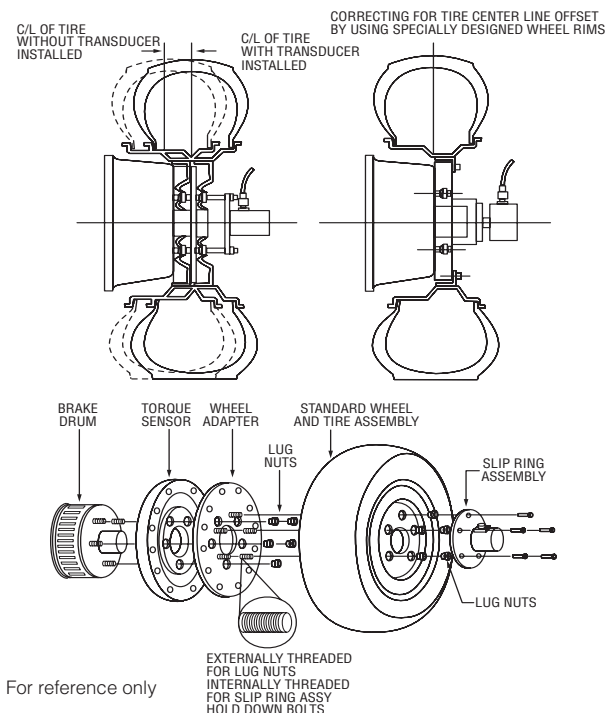

For reference only

TYPICAL SYSTEM DIAGRAM

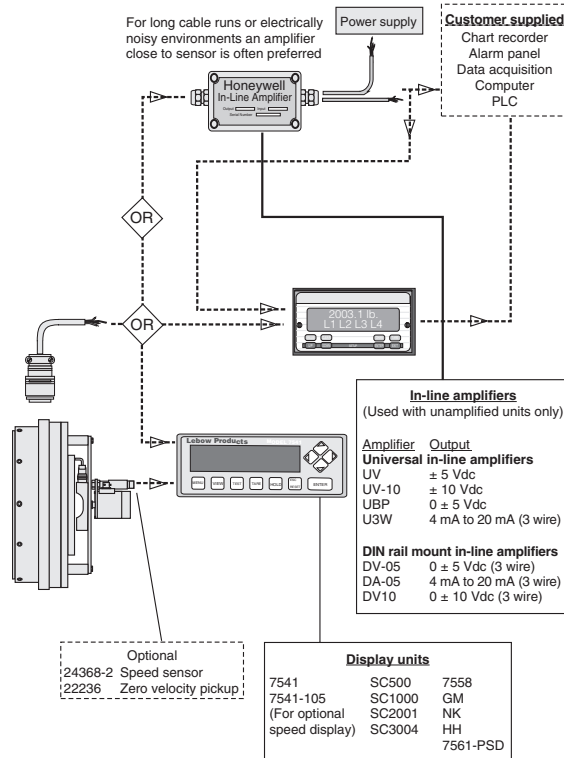

Mating connectors & cables

- 023-LW181-023-LF Mating connector
- 023-LW180-034-LF Mating connector, standard speed pickup
- 023-LW180-033 Mating connector, zero velocity speed pickup
- 7205-76-XX* Mating connector & 6 conductor cable (unamplified unit with sense leads but not shunt cal)
- 7205-75-XX** Mating connector & 4 conductor cable (unamplified unit without sense leads but not shunt cal)
- 7205-83-XX* Mating connector & 6 conductor cable for connection to instrument 7541
- 7205-82-XX** Mating connector & 4 conductor cable for connection to instrument 7541
- 7204-00-XX* Speed sensor cable, pigtail leads at instrument
- 7204-16-XX* Speed sensor cable to instrument 7541
- 7220-47-XX* Zero velocity speed sensor cable, pigtail leads at instrument
- 7220-119-XX* Zero velocity speed sensor cable to instrument 7541

* XX represents length in feet 100 ft maximum

** XX represents length in feet 20 ft maximum

Model 1246

Wheel Torque Sensor

Warranty. Honeywell warrants goods of its manufacture as being free of defective materials and faulty workmanship. Honeywell's standard product warranty applies unless agreed to otherwise by Honeywell in writing; please refer to your order acknowledgement or consult your local sales office for specific warranty details. If warranted goods are returned to Honeywell during the period of coverage, Honeywell will repair or replace, at its option, without charge those items it finds defective. **The foregoing is buyer's sole remedy and is in lieu of all warranties, expressed or implied, including those of merchantability and fitness for a particular purpose. In no event shall Honeywell be liable for consequential, special, or indirect damages.**

While we provide application assistance personally, through our literature and the Honeywell web site, it is up to the customer to determine the suitability of the product in the application.

 **WARNING**
PERSONAL INJURY

- DO NOT USE these products as safety or emergency stop devices or in any other application where failure of the product could result in personal injury.

Failure to comply with these instructions could result in death or serious injury.

 **WARNING**
MISUSE OF DOCUMENTATION

- The information presented in this datasheet is for reference only. DO NOT USE this document as product installation information.
- Complete installation, operation and maintenance information is provided in the instructions supplied with each product.

Failure to comply with these instructions could result in death or serious injury.

Find out more

Honeywell serves its customers through a worldwide network of sales offices, representatives and distributors. For application assistance, current specifications, pricing or name of the nearest Authorized Distributor, contact your local sales office. To learn more about Honeywell's test and measurement products, call **+1-614-850-5000**, visit **www.honeywell.com/sensotec**, or e-mail inquiries to **info.tm@honeywell.com**

Sensing and Control
Honeywell
1985 Douglas Drive North
Golden Valley, MN 55422
www.honeywell.com

008773-2-EN IL50 GLO
September 2009

Copyright © 2009 Honeywell International Inc. All rights reserved.

Honeywell