

SS0402 THERMOMETER

攝氏及華氏體溫計

FEATURES 功能敘述：

- TEMPERATURE RANGE 溫度範圍 32.00°C (89.60°F) ~ 43.00°C (109.40°F)
- RESOLUTION 0.01°C (0.01°F), ACCURACY ±0.1°C (±0.2°F)
- LOW BATTERY DETECTOR 低電壓檢測
- BUZZER ALARM 警示聲及 AUTO POWER-OFF
- TC327203C 為 °C DISPLAY, TC327203F 為 °F DISPLAY
- SENSOR 溫度感測使用 503ET
- CHIP SIZE = 1970 X 2200 um*um

ELECTRICAL CHARACTERISTICS 電氣規格：

CHARACTERISTICS	SYMBOL	MIN.	TYPE	MAX.	UNIT	REMARK
工作電壓 Operating Voltage	Vdd	1.30	1.50	1.65	V	
工作電流 Operating Current	Idd	—	45	—	uA	Average current
靜態電流 Stand-by Current	Ist	—	0	—	uA	LCD not Display
推動電流 BZ Driving Current	Idv	1.5	—	—	mA	Vout=1/2Vdd
推動電流 BZ Sinking Current	Isk	—	—	-2.0	mA	Vout=1/2Vdd
振盪頻率 Oscillate Frequency	Fosc	—	128	—	KHz	RC Oscillator
工作溫度 Operating Temperature	Topr	-20	—	75	°C	
儲存溫度 Storage Temperature	Tstg	-20	—	125	°C	

APPLICATION DIAGRAM 參考電路圖：

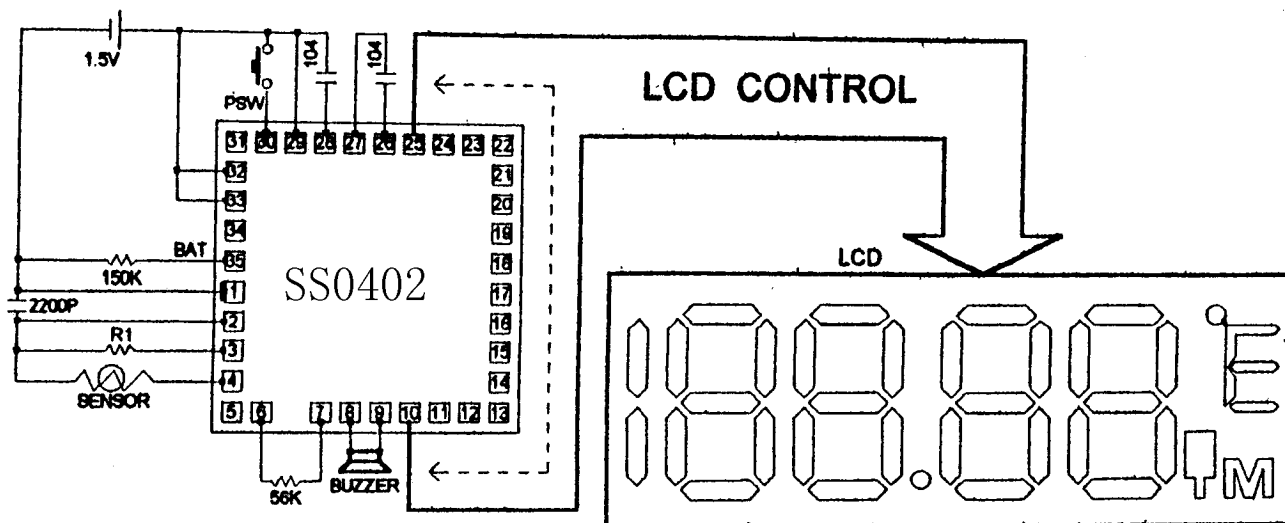

- IC chip substrate don't connect to VDD or VSS.
- All SPEC and applications shown above subject to change without prior notice.

SUNSTAR 深圳市商斯达电子有限公司
SHENZHEN SUNSTAR ELECTRONICS CO.,LTD.

地址(Add):深圳福田区福华路福庆街鸿图大厦1602室
RM 1602,Hongtu Bldge,Fuhua Rd, Futian Region,Shenzhen China
电话(Tel):0755-3600718 3758073 邮编(PC):518033
传真(Fax):0755-3376182 E-mail:szsunstr@public.szptt.net.cn
网址: Http://www.sunstare.com/ 手机:(0)13902971329
西安办事处电话:(0)13609291696 191-8454356
北京办事处电话:(0)13501189838 191-8886650
上海办事处电话:(0)13701955389 191-3789221

集成电路
传感器
单片机

SS0402 PRODUCT SPECIFICATION

FUNCTION FLOW DIAGRAM :

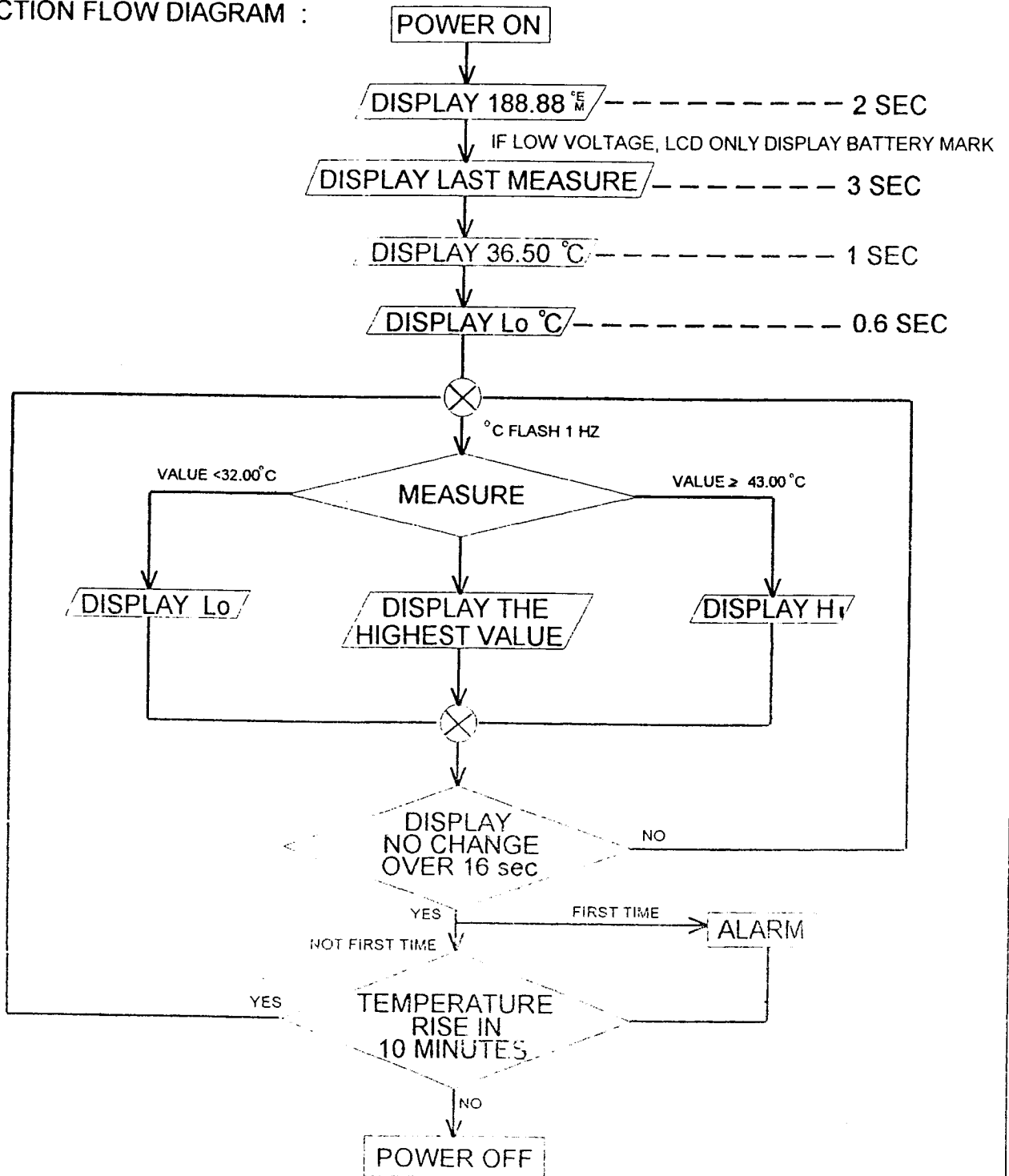

SS0402 THERMOMETER PRODUCT SPECIFICATION (1.5V)

- <1> POWER SW: PUSH SWITCH CAN TURN ON OR TURN OFF THE THERMOMETER.
- <2> AT POWER ON :
- A. LCD DISPLAY **88.88** 2 SECOND AT FIRST.
 - B. FOLLOWING A; DISPLAY THE HOLDING TEMPERATURE OF THE LAST MEASURED ABOUT 3 SECOND, AND CHARACTER "m" ALSO DISPLAY.
 - C. FOLLOWING B; AFTER DISPLAY 36.50 °C 1 SECOND, AND DISPLAY " Lo" ABOUT 0.6 SECOND AGAIN.
 - D. FOLLOWING C; WHEN MEASURING ,THE MARK °C IS FLASH BY 1HZ.
 - E. THE DISPLAY TEMPERATURE ALWAYS KEEP HIGHER DURING MEASURING.
 - F. IF THE TEMPERATURE < 32.00 °C , THE LCD DISPLAY " Lo °C".
 - G. IF THE TEMPERATURE \geq 43.00 °C , THE LCD DISPLAY " Hi °C".
 - H. IF THE MEASURED TEMPERATURE IS NO CHANGE MORE THAN 16 SECOND, THE MEASUREMENT IS OVER AND °C MARK FLASH STOP.THE BUZZER ALARM "Bi-Bi-Bi——Bi-Bi-Bi——" ABOUT 4 SEC, AS BELOW:
Bi———Bi———Bi———
0.125S 0.125S 0.125S 0.125S 0.125S 0.375S
 - I. IT WILL AUTO POWER OFF WHEN MEASUREMENT IS OVER THAN 10 MINUTES.
 - J. WHEN MEASUREMENT IS OVER, IF TEMPERATURE RISES WITHIN 10 MINUTES, THE °C MARK WILL REFLASH AND MEASURED AGAIN (REPEAT STEP 2-D), BUT THE TEMPERATURE IS HOLDING, THE BUZZER NO ALARM.
 - K. OPERATING AVERAGE CURRENT \leq 45 μ A .
- <3> PUSH SWITCH CAUSE A BUZZER ALARM "Bi" ABOUT 0.125 SECOND.
- <4> THE STAND-BY CURRENT \leq 0.5 μ A AT POWER OFF STATUS.
- <5> THE FREQUENCY OF BUZZER IS 5.3KHZ.
- <6> AFTER (2-A), IF THE BATTERY VOLTAGE IS LOW, THE LCD ONLY DISPLAY BATTERY MARK "v" ,MEANS THE MEASUREMENT MAYBE NOT ACCURATE.THE LOW VOLTAGE DETECT: 1.35V \pm 0.05V
- <7> TEST2 PIN CONNECT VDD, DISPLAY IS REAL TIME TEMPERATURE NOT THE HIGHEST TEMPERATURE IN ORDER TO ADJUST REFERENCE RESISTER.

- <8> LOW BATTERY RESISTOR IS ABOUT $97K\Omega$ ($R3=110K\Omega$ PARALLEL TO $R_{adj}=820K\Omega$). IF BATTERY MARK WAS SHOWN WHEN VDD IS MORE THAN 1.4V , THE PARALLEL RESISTOR R_{adj} MUST BE CANCEL.
- <9> FOR MATCHING 503ET AND 833ET SENSOR, THE VALUE OF R1 IS ACCORDING TO DIFFERENTIAL SENSOR TYPE (SEE PAGE 11).
- <10> FOR SENSOR TYPE IS ONLY USED 503ET AND 833ET.
- <11> THE ACCURACY SPECIFICATION IS FOLLOWING BELOW:

Temperature	Specification
$T < 34.00^{\circ}\text{C}$	$\pm 0.2^{\circ}\text{C}$
$34.00^{\circ}\text{C} \leq T < 40.00^{\circ}\text{C}$	$\pm 0.1^{\circ}\text{C}$
$40.00^{\circ}\text{C} \leq T$	$\pm 0.2^{\circ}\text{C}$

PIN DESCRIPTION

PIN NAME	DESCRIPTION

1	VSS POWER PIN.
2	SC REFERENCE AND SENSOR FREQUENCY INPUT PIN. THE REFERENCE AND SENSOR FREQUENCY GENERATOR CONSTSTS OF PIN 2,3,4.
3	RF PMOS OPEN DRAIN, CONNECT TO THE REFERENCE RESISTOR.
4	RS PMOS OPEN DRAIN, CONNECT TO THE SENSOR RESISTOR.
5	TEST1 TEST PIN ,FOR IC TEST ONLY.
6	OSCI SYSTEM FREQUENCY INPUT PIN.
7	OSCO SYSTEM FREQUENCY OUTPUT PIN.
8	BZ1 OUTPUT PIN, THE BUFFER OF BUZZER.
9	BZ2 OUTPUT PIN, THE BUFFER OF BUZZER.
10	COM1 OUTPUT PIN, CONNECT TO LCD PIN 1.
11	COM2 OUTPUT PIN, CONNECT TO LCD PIN 2.
12	COM3 OUTPUT PIN, CONNECT TO LCD PIN 3.
13	SA1 OUTPUT PIN, CONNECT TO LCD PIN 4.
14	SA2 OUTPUT PIN, CONNECT TO LCD PIN 5.
15	SA3 OUTPUT PIN, CONNECT TO LCD PIN 6.
16	SB1 OUTPUT PIN, CONNECT TO LCD PIN 7.
17	SB2 OUTPUT PIN, CONNECT TO LCD PIN 8.
18	SB3 OUTPUT PIN, CONNECT TO LCD PIN 9.
19	SC1 OUTPUT PIN, CONNECT TO LCD PIN 10.
20	SC2 OUTPUT PIN, CONNECT TO LCD PIN 11.
21	SC3 OUTPUT PIN, CONNECT TO LCD PIN 12.

22	SD1	OUTPUT PIN, CONNECT TO LCD PIN 13.
23	SD2	OUTPUT PIN, CONNECT TO LCD PIN 14.
24	SD3	OUTPUT PIN, CONNECT TO LCD PIN 15.
25	SE1	OUTPUT PIN, CONNECT TO LCD PIN 16.
26	C512	THE PIN 26,27 IS DOUBLER VOLTAGE 3V CAPACITOR CONNECT.
27	CAP	
28	VEE	VOLTAGE 3V
29	VDD	
30	PSW	PULL LOW INPUT PIN. PUSH SWITCH TO POWER ON/OFF.
31	TEST2	PULL LOW TEST PIN. WHEN THIS PIN CONNECT TO VDD ON PRODUCTION, THE LCD WILL DISPLAY REALTIME VALUE (NOT THE HIGHEST VALUE).
32	VOP	IN ORDER TO SELECT VDD USE 1.5V OR 3V, WHEN SELECT 1.5V THIS PIN CONNECT TO VDD, OTHERWISE CONNECT TO VSS.
33	HALF	CONNECT TO 1.5V.
34	P3V	OUTPUT PIN. FOR 3V APPLICATION USE ONLY.
35	BAT	FOR THE LOW VOLTAGE DETECTING.

OPERATING PARAMETER:(VDD=1.5V)

1. OPERATING VOLTAGE : 1.3V - 1.65V
2. OPERATING AVERAGE CURRENT: $\leq 45 \mu\text{A}$.
3. INPUT VOLTAGE : $V_{IL} \leq V_{SS}+0.3\text{V}$
 $V_{IH} \geq V_{DD}-0.3\text{V}$
4. OUTPUT VOLTAGE : $V_{OL} \leq V_{SS}+0.1\text{V}$
 $V_{OH} \geq V_{DD}-0.1\text{V}$
5. BUZZER DRIVING CURRENT : $\geq 1.5\text{mA}$ ($V_{out}=1/2 V_{DD}$)
BUZZER SINKING CURRENT : $\leq -2.0\text{mA}$ ($V_{out}=1/2 V_{DD}$)

BLOCK DIAGRAM :

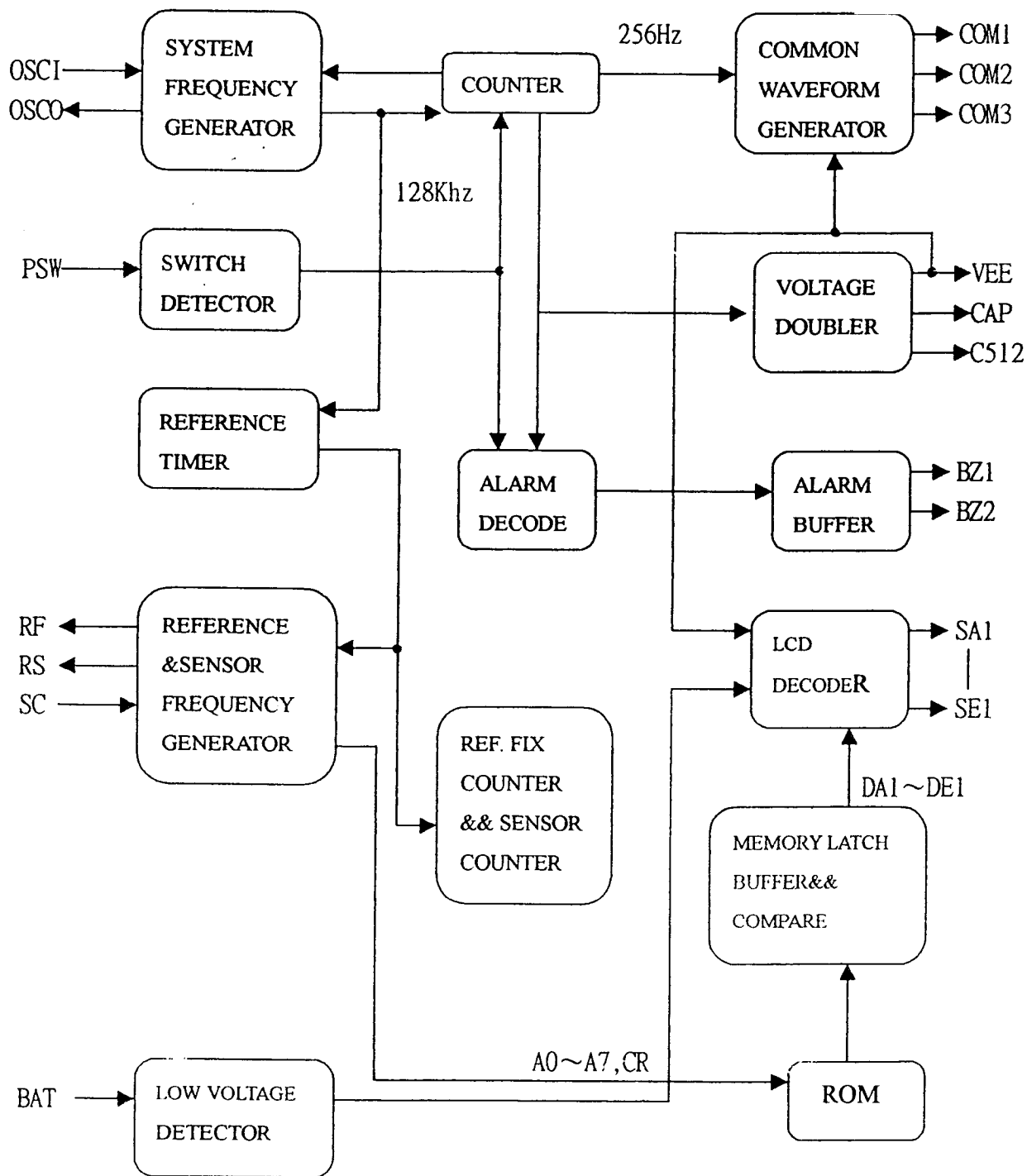

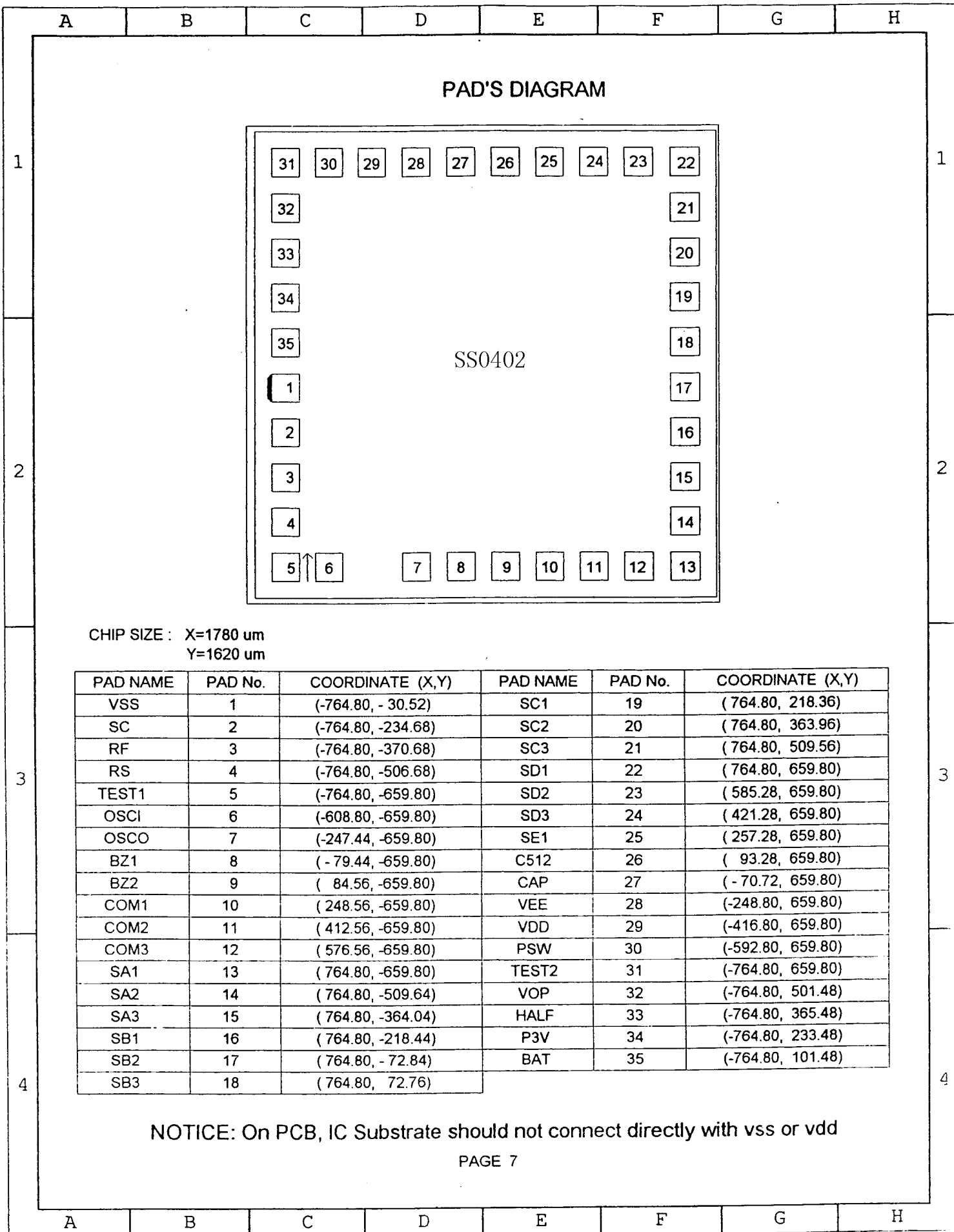

CHIP SIZE : X=1780 um
Y=1620 um

PAD NAME	PAD No.	COORDINATE (X,Y)	PAD NAME	PAD No.	COORDINATE (X,Y)
VSS	1	(-764.80, -30.52)	SC1	19	(764.80, 218.36)
SC	2	(-764.80, -234.68)	SC2	20	(764.80, 363.96)
RF	3	(-764.80, -370.68)	SC3	21	(764.80, 509.56)
RS	4	(-764.80, -506.68)	SD1	22	(764.80, 659.80)
TEST1	5	(-764.80, -659.80)	SD2	23	(585.28, 659.80)
OSCI	6	(-608.80, -659.80)	SD3	24	(421.28, 659.80)
OSCO	7	(-247.44, -659.80)	SE1	25	(257.28, 659.80)
BZ1	8	(-79.44, -659.80)	C512	26	(93.28, 659.80)
BZ2	9	(84.56, -659.80)	CAP	27	(-70.72, 659.80)
COM1	10	(248.56, -659.80)	VEE	28	(-248.80, 659.80)
COM2	11	(412.56, -659.80)	VDD	29	(-416.80, 659.80)
COM3	12	(576.56, -659.80)	PSW	30	(-592.80, 659.80)
SA1	13	(764.80, -659.80)	TEST2	31	(-764.80, 659.80)
SA2	14	(764.80, -509.64)	VOP	32	(-764.80, 501.48)
SA3	15	(764.80, -364.04)	HALF	33	(-764.80, 365.48)
SB1	16	(764.80, -218.44)	P3V	34	(-764.80, 233.48)
SB2	17	(764.80, -72.84)	BAT	35	(-764.80, 101.48)
SB3	18	(764.80, 72.76)			

NOTICE: On PCB, IC Substrate should not connect directly with vss or vdd

SS0402 THERMOMETER APPLICATION (1.5V)

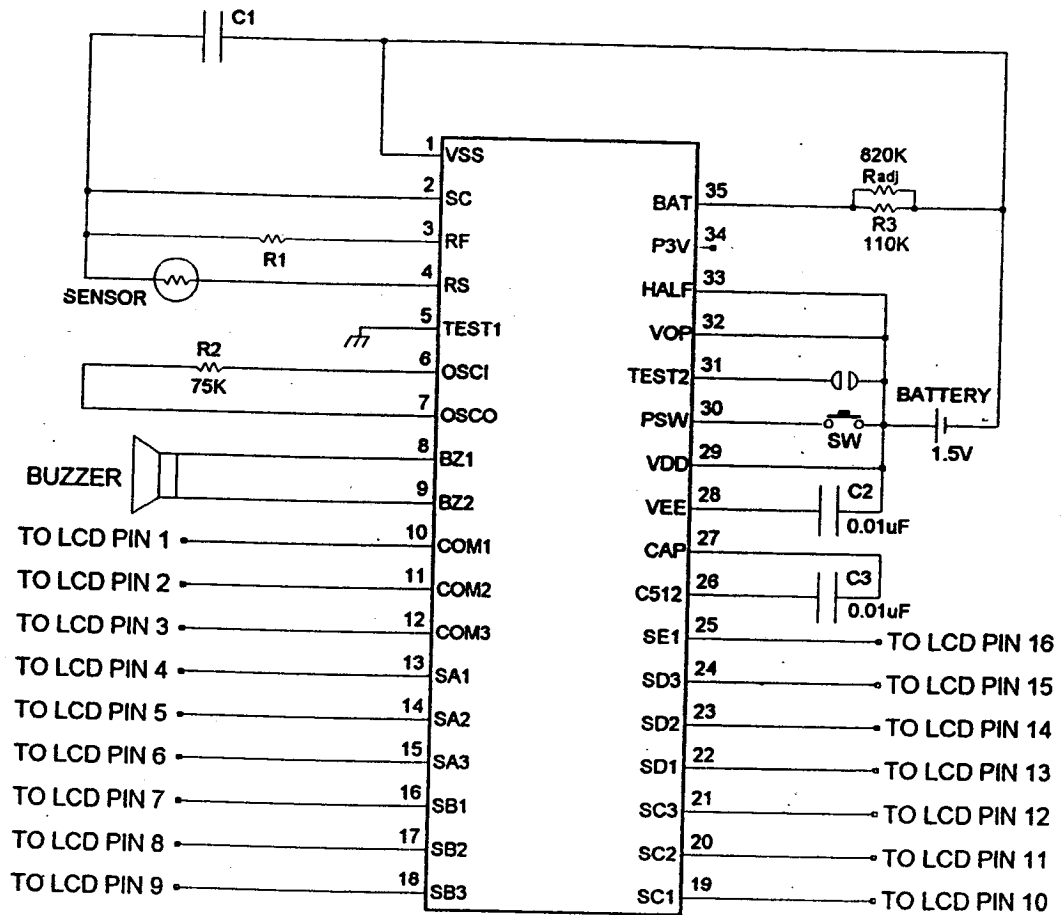

REMARK 1: R1 SELECTED ACCORDING TO SENSOR TYPE.

2: $R3/R_{adj} = 97Kohm$

3. SC CAPACITOR SELECT ACCORDING TO SENSOR TYPE:

IF USE ET503 SENSOR TYPE, C1 SELECT 2200pF

IF USE ET833 SENSOR TYPE, C1 SELECT 1000pF

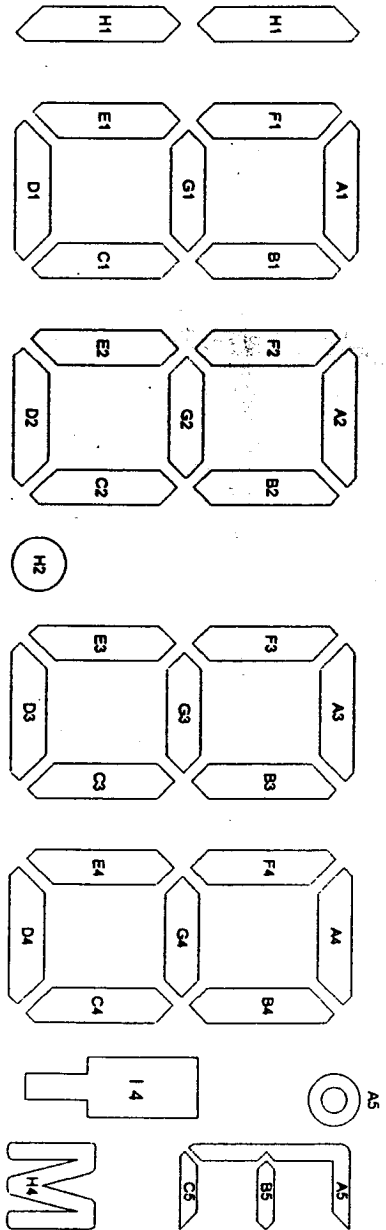

- 1
- 2
- 3
- 4
- 5
- 6
- 7
- 8
- 9
- 10
- 11
- 12
- 13
- 14
- 15
- 16

	1	2	3	4	5	6	7	8	9	10	11	12	13	14	15	16
COM1	COM1			F1	A1	B1	F2	A2	B2	F3	A3	B3	F4	A4	B4	A5
COM2		COM2		E1	G1	C1	E2	G2	C2	E3	G3	C3	E4	G4	C4	B5
COM3			COM3	H1	D1			D2	H2		D3		I4	D4	H4	C5

SPEC: A. 1/3 DUTY, 1/2 BI LCD USES 3V)
 B. $V_{MH} = 1.5V$

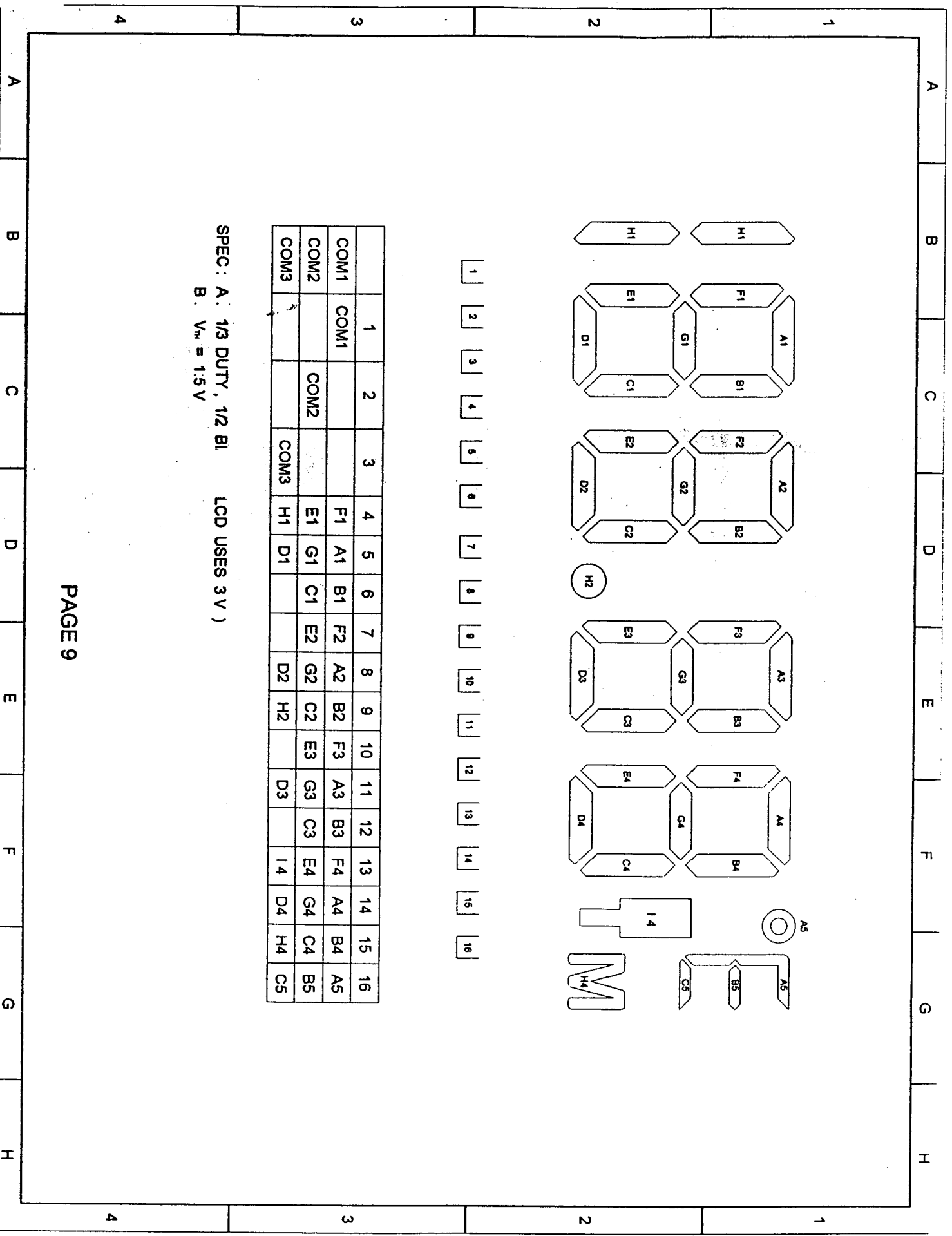

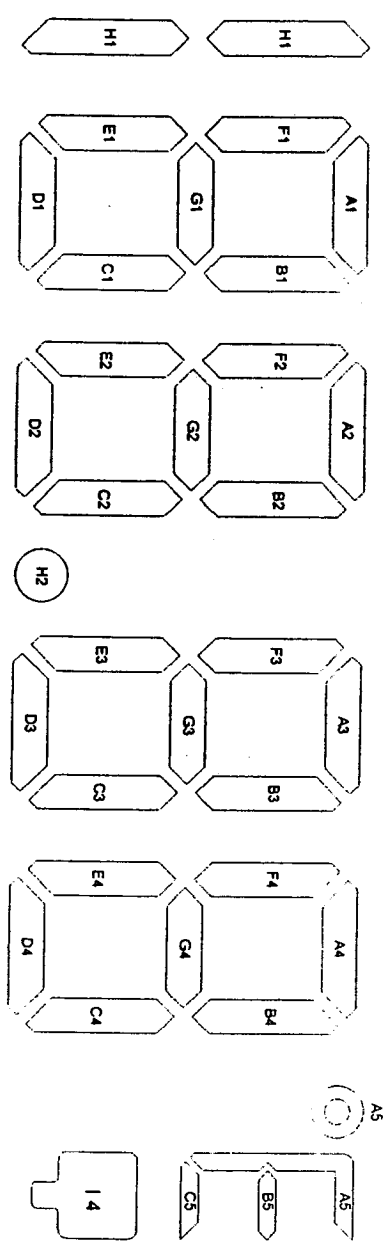

- 1
- 2
- 3
- 4
- 5
- 6
- 7
- 8
- 9
- 10
- 11
- 12
- 13
- 14
- 15
- 16

	1	2	3	4	5	6	7	8	9	10	11	12	13	14	15	16
COM1	COM1			F1	A1	B1	F2	A2	B2	F3	A3	B3	F4	A4	B4	A5
COM2		COM2		E1	G1	C1	E2	G2	C2	E3	G3	C3	E4	G4	C4	B5
COM3			COM3	H1	D1			D2	H2		D3		I 4	D4		C5

SPEC : A. 1/3 DUTY, 1/2 BIAS. (LCD USES 3 V)
 B. $V_{m} = 1.5 V$

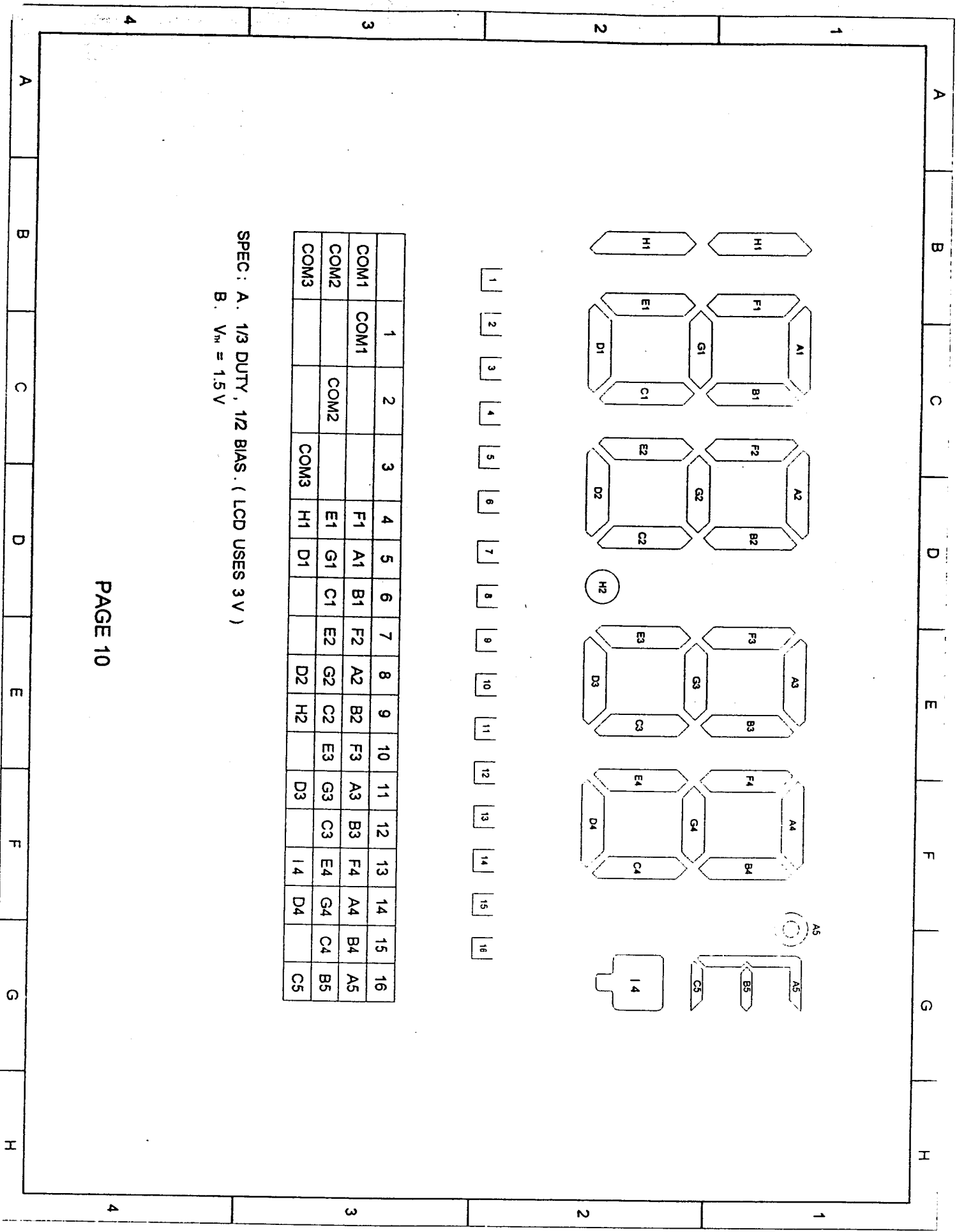

IC TEST DATA:

A.SENSOR 503ET ZERO-POWER RESISTANCE AND MATCHING RF RESISTANCE TEST:

TYPE	SENSOR SPEC. (37°C) RESISTANCE	RF APPLICATION RESISTANCE
A	29.137	29.191
B	29.242	29.292
C	29.348	29.403
D	29.454	29.502
E	29.561	29.618
F	29.668	29.720
G	29.775	29.817
H	29.883	29.926

TYPE	SENSOR SPEC. (37°C) RESISTANCE	RF APPLICATION RESISTANCE
I	29.991	30.035
J	30.100	30.152
K	30.209	30.256
L	30.318	30.370
M	30.428	30.474
N	30.538	30.594
O	30.649	30.702
P	30.759	30.814

UNIT:KΩ

B.SENSOR 833ET ZERO-POWER RESISTANCE AND MATCHING RF RESISTANCE TEST:

TYPE	SENSOR SPEC. (37°C) RESISTANCE	RF APPLICATION RESISTANCE
A	48.567	48.593
B	48.737	48.775
C	48.913	48.944
D	49.090	49.132
E	49.268	49.300
F	49.446	49.483
G	49.625	49.656
H	49.805	49.839

TYPE	SENSOR SPEC. (37°C) RESISTANCE	RF APPLICATION RESISTANCE
I	49.985	50.022
J	50.166	50.203
K	50.348	50.383
L	50.530	50.568
M	50.713	50.750
N	50.897	50.933
O	51.081	51.118
P	51.265	51.298

SUNSTAR 深圳市商斯达电子有限公司

SHENZHEN SUNSTAR ELECTRONICS CO.,LTD.

集成电路
传感器
单片机

地址(Add): 深圳福田区福华路福庆街鸿图大厦1602室
 RM 1602, Hongtu Bldg, Fuhua Rd, Futian Region, Shenzhen, China
 电话(Tel): 0755-3600718 3338339 邮编(PC): 518033
 传真(Fax): 0755-3338339 E-mail: szsunstr@public.szptt.net.cn
 网址: <http://www.sunstar.com/> 手机: (0)13902971329
 西安办事处电话: (0)13609291696 191-8454356
 北京办事处电话: (0)13501189838 191-8886650
 上海办事处电话: (0)13701955389 191-3789221

欢迎索取免费详细资料、设计选型指南和光盘、样品；产品繁多未能尽录，欢迎来电查询。

[中国传感器科技信息网：HTTP://WWW.SENSOR-IC.COM/](http://WWW.SENSOR-IC.COM/)

[工控安防网：HTTP://WWW.PC-PS.NET/](http://WWW.PC-PS.NET/)

[消费电子专用电路网：HTTP://WWW.SUNSTARE.COM/](http://WWW.SUNSTARE.COM/)

E-MAIL：xjr5@163.com szss20@163.com

MSN：suns8888@hotmail.com

QQ：195847376

地址：深圳市福田区福华路福庆街鸿图大厦 1602 室

电话：0755-83376549 83376489 83387030 83387016

传真：0755-83376182 83338339 邮编：518033 手机：(0)13902971329

深圳展销部：深圳华强北路赛格电子市场 2583 号 TEL/FAX：
0755-83665529 25059422

北京分公司：北京海淀区知春路 132 号中发电子大厦 3097 号

TEL：010-81159046 82615020 13501189838 FAX：010-82613476

上海分公司：上海市北京东路 668 号上海赛格电子市场 2B35 号

TEL：021-28311762 56703037 13701955389 FAX：021-56703037

西安分公司：西安高新开发区 20 所(中国电子科技集团导航技术研究所)
西安劳动南路 88 号电子商城二楼 D23 号

TEL：029-81022619 13072977981 FAX:029-88789382

成都：TEL:(0)13717066236

技术支持：0755-83394033 13501568376