



AWL6152

2.4 GHz Wireless LAN
Power Amplifier Module

ADVANCED PRODUCT INFORMATION - Rev 0.1

FEATURES

- InGaP HBT Technology
- < 3% EVM at +26 dBm Output Power (+5 V Supply), with 802.11g Modulation at 54 Mbps Data Rate
- < 3% EVM at +22 dBm Output Power (+3.3 V Supply), with 802.11g Modulation at 54 Mbps Data Rate
- +3 V to +5 V Supply
- High Efficiency
- 4 x 4 x 1.5 mm Surface Mount Module
- 50Ω - Matched RF Ports for Reduced External Component Count

APPLICATIONS

- 802.11g/b WLAN Stations and Client Cards
- 802.11g/b WLAN Access Points

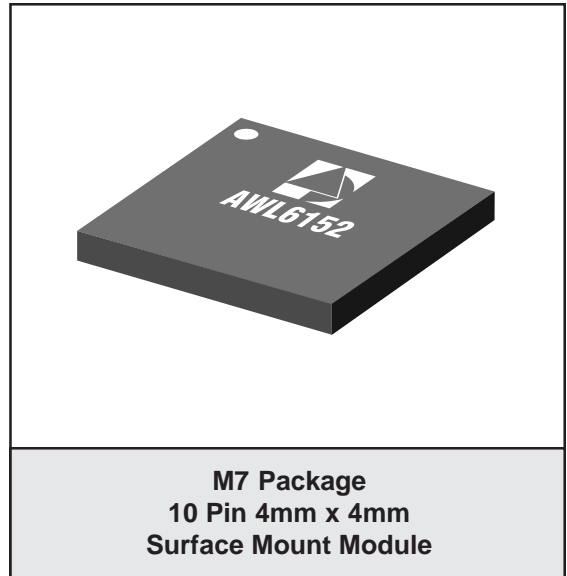

PRODUCT DESCRIPTION

The ANADIGICS AWL6152 WLAN Power Amplifier is an easy to use module that delivers high levels of linearity and efficiency for high data rate applications. Designed for the 2.4 GHz WLAN standards, it supports the 54 Mbps data rates specified in IEEE 802.11g.

Requiring a single +3 V to +5 V supply and a reference voltage input, the AWL6152 reduces system power consumption by offering a low leakage current while the amplifier is shut down.

No external circuits are required for RF impedance matching, thus reducing component costs and making it easy to incorporate the device into new designs.

The AWL6152 is manufactured using an advanced InGaP HBT technology that offers state-of-the-art reliability, temperature stability and ruggedness. It is offered in a 4mm x 4mm x 1.5mm surface mount module optimized for a 50Ω system.

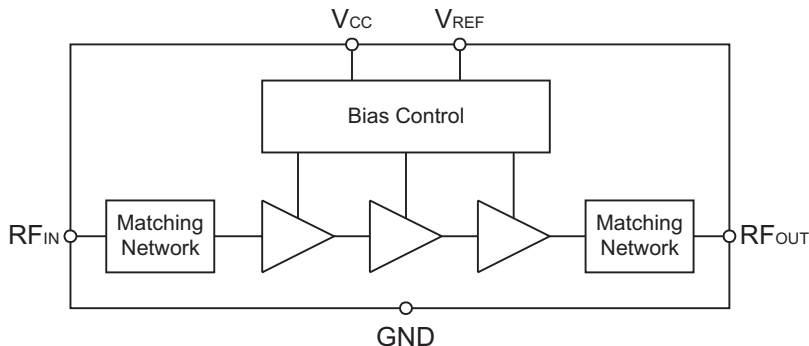

Figure 1: Module Block Diagram

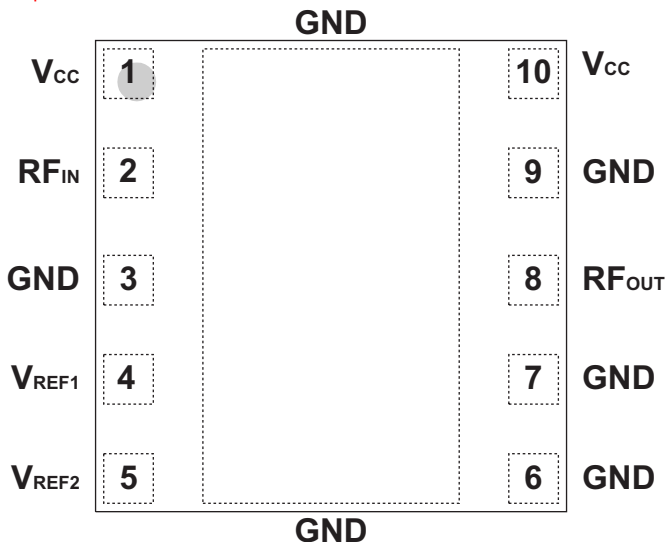

Figure 2: Pinout (X-ray Top View)

Table 1: Pin Description

PIN	NAME	DESCRIPTION
1	V _{CC}	Supply Voltage
2	RF _{IN}	RF Input
3	GND	Ground
4	V _{REF1}	Reference Voltage 1
5	V _{REF2}	Reference Voltage 2
6	GND	Ground
7	GND	Ground
8	RF _{OUT}	RF Output
9	GND	Ground
10	V _{CC}	Supply Voltage

ELECTRICAL CHARACTERISTICS**Table 2: Absolute Minimum and Maximum Ratings**

PARAMETER	MIN	MAX	UNIT
Supply Voltage (V_{CC})	0	+5.5	V
Reference Voltages (V_{REF1} , V_{REF2})	0	+3.5	V
RF Input Power (P_{IN})	-	+10	dBm
Storage Temperature	-40	+150	°C

Stresses in excess of the absolute ratings may cause permanent damage. Functional operation is not implied under these conditions. Exposure to absolute ratings for extended periods of time may adversely affect reliability.

Table 3: Operating Ranges

PARAMETER	MIN	TYP	MAX	UNIT	COMMENTS
Operating Frequency (f)	2400	-	2485	MHz	
Supply Voltage (V_{CC})	+3.0	-	+5.5	V	
Reference Voltages (V_{REF1} , V_{REF2})	- 0	+2.85 -	- +0.5	V	PA"on" PA"shut down"
RF Output Power (P_{OUT})	- - - -	+22 +26 +26 +30	- - - -	dBm	V_{CC} = +3.3 V, 802.11g modulation V_{CC} = +5.0 V, 802.11g modulation V_{CC} = +3.3 V, 802.11b modulation V_{CC} = +5.0 V, 802.11b modulation
Case Temperature (T_C)	-25	-	+85	°C	

The device may be operated safely over these conditions; however, parametric performance is guaranteed only over the conditions defined in the electrical specifications.

Table 4: Electrical Specifications - 802.11g Modulation, 54 Mbps Data Rate
 (T_C = +25 °C, V_{CC} = +3.3 V, V_{REF1} = V_{REF2} = +2.85 V, P_{OUT} = +22 dBm, 50 Ω system)

PARAMETER	MIN	TYP	MAX	UNIT	COMMENTS
Gain	-	30	-	dB	
Gain Ripple	-	-	0.3	dB	within each channel
Constellation RMS Error	-	2.5	-	%	
	-	-32	-	dB	
Spectrum Mask at ±11 MHz Offset	-	-30	-20	dB	
Spectrum Mask at ±20 MHz Offset	-	-45	-28	dB	
Spectrum Mask at ±30 MHz Offset	-	-50	-40	dB	
Current Consumption					
V _{CC}	-	245	-		
V _{REF1}	-	3.5	-	mA	
V _{REF2}	-	2	-		
Leakage Current	-	<10	-	μA	V _{REF1} = V _{REF2} = 0 V
Input Return Loss	-	<-10	-	dB	50 Ω impedance
Harmonics					
2fo	-	-45	-	dBc	
3fo	-	-56	-		
Maximum load mismatch stress with no permanent degradation or failure	10:1	-	-	VSWR	V _{CC} = +5.5 V

Table 5: Electrical Specifications - 802.11g Modulation, 54 Mbps Data Rate
(T_c = +25 °C, V_{CC} = +5 V, V_{REF1} = V_{REF2} = +2.85 V, P_{OUT} = +26 dBm, 50 Ω system)

PARAMETER	MIN	TYP	MAX	UNIT	COMMENTS
Gain	-	30	-	dB	
Gain Ripple	-	-	0.3	dB	within each channel
Constellation RMS Error	-	3	-	%	
	-	-30	-	dB	
Spectrum Mask at ±11 MHz Offset	-	-30	-20	dB	
Spectrum Mask at ±20 MHz Offset	-	-42	-28	dB	
Spectrum Mask at ±30 MHz Offset	-	-50	-40	dB	
Current Consumption					
V _{CC}	-	355	-		
V _{REF1}	-	3.5	-	mA	
V _{REF2}	-	2	-		
Leakage Current	-	<10	-	μA	V _{REF1} = V _{REF2} = 0 V
Input Return Loss	-	<-10	-	dB	50 Ω impedance
Harmonics					
2fo	-	-42	-	dBc	
3fo	-	-56	-		
Maximum load mismatch stress with no permanent degradation or failure	10:1	-	-	VSWR	V _{CC} = +5.5 V

Table 6: Electrical Specifications - 802.11b Modulation**(T_C = +25 °C, V_{CC} = +3.3 V, V_{REF1} = V_{REF2} = +2.85 V, P_{OUT} = +26 dBm, 50 Ω system)**

PARAMETER	MIN	TYP	MAX	UNIT	COMMENTS
Gain	-	30	-	dB	
First Sidelobe Power	-	-	-30	dBc	
Second Sidelobe Power	-	-	-50	dBc	
Current Consumption		350			
V _{CC}	-	3.5	-	mA	
V _{REF1}	-	2	-		
V _{REF2}	-		-		
Leakage Current	-	<10	-	μA	V _{REF1} = V _{REF2} = 0 V
Input Return Loss	-	<-10	-	dB	50 Ω impedance
Harmonics					
2fo	-	-50	-	dBc	CW Input
3fo	-	-63	-		
Maximum load mismatch stress with no permanent degradation or failure	10:1	-	-	VSWR	V _{CC} = +5.5 V

Table 7: Electrical Specifications - 802.11b Modulation**(T_C = +25 °C, V_{CC} = +5 V, V_{REF1} = V_{REF2} = +2.85 V, P_{OUT} = +30 dBm, 50 Ω system)**

PARAMETER	MIN	TYP	MAX	UNIT	COMMENTS
Gain	-	30	-	dB	
First Sidelobe Power	-	-	-30	dBc	
Second Sidelobe Power	-	-	-50	dBc	
Current Consumption V _{CC} V _{REF1} V _{REF2}	- - -	570 3.5 2	- - -	mA	
Leakage Current	-	<10	-	μA	V _{REF1} = V _{REF2} = 0 V
Input Return Loss	-	<-10	-	dB	50 Ω impedance
Harmonics 2fo 3fo	- - -	-50 -63	- -	dBc	CW Input
Maximum load mismatch stress with no permanent degradation or failure	10:1	-	-	VSWR	V _{CC} = +5.5 V

PERFORMANCE DATA

Figure 3: Typical EVM⁽¹⁾ vs. Output Power
(T_A = +25 °C, V_{REF1} = V_{REF2} = +2.85 V
802.11g modulation, 54 Mbps data rate)

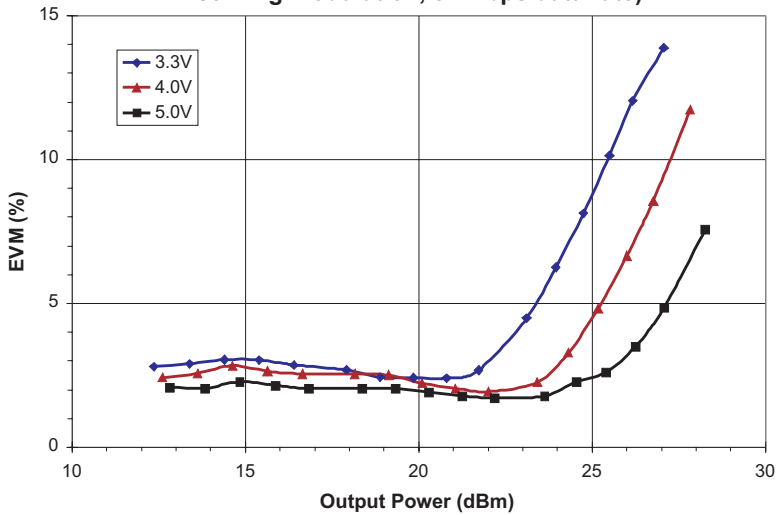

Notes:

(1) Uncorrected EVM. Source EVM approx. 1.2%.

Figure 4: Typical Current vs. Output Power
(T_A = +25 °C, V_{REF1} = V_{REF2} = +2.85 V
802.11g modulation, 54 Mbps data rate)

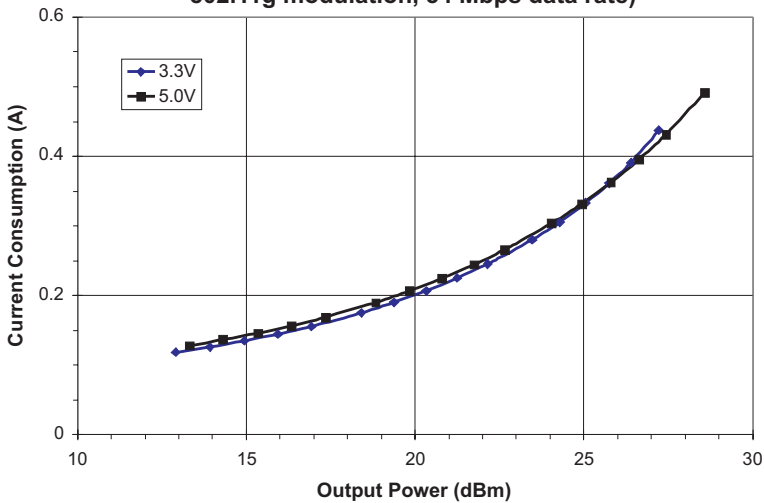

APPLICATION INFORMATION

The only external components required for the AWL6152 are bypass capacitors for the supply and reference voltages (see Figure 3). V_{REF1} and V_{REF2}

may be tied together, and when both are pulled down to 0 V, the amplifier is placed in a low-current shut down mode.

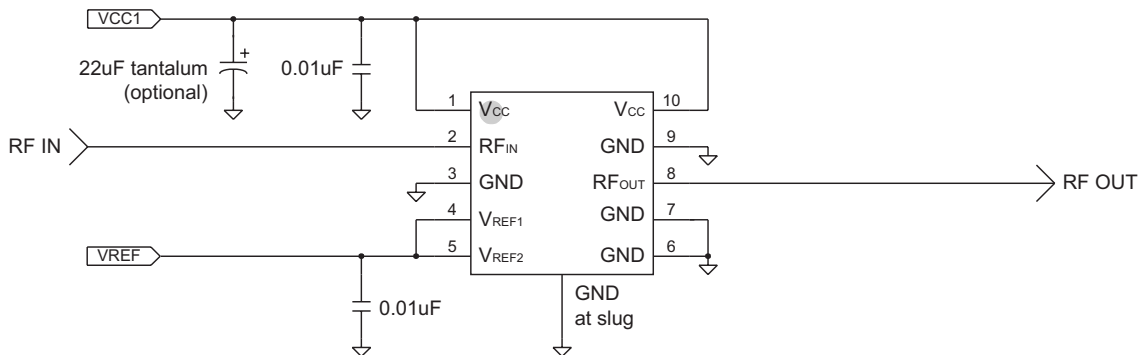
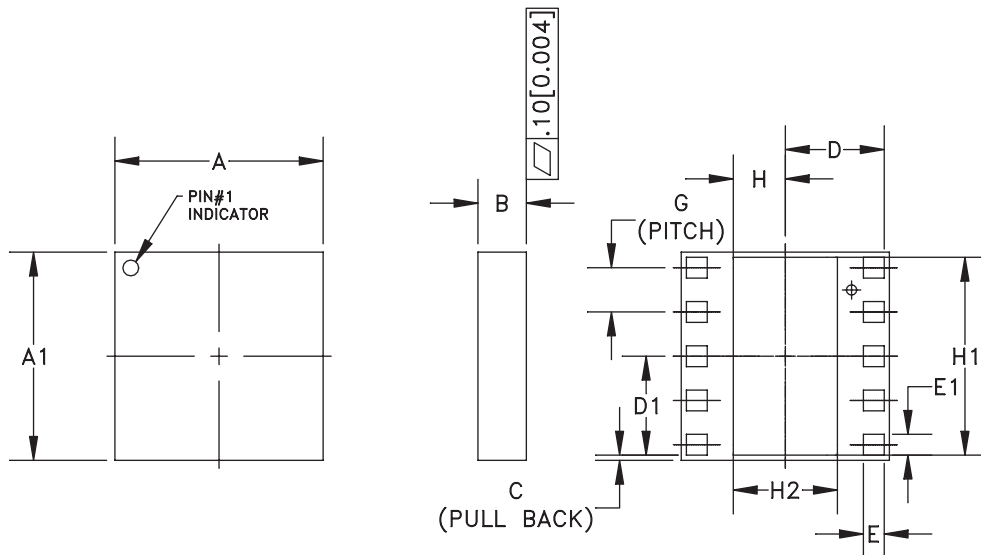

Figure 5: Application Circuit



SYMBOL	MILLIMETERS			INCHES			NOTE
	MIN.	NOM.	MAX.	MIN.	NOM.	MAX.	
A	3.88	4.00	4.12	0.152	0.157	0.162	-
A1	3.88	4.00	4.12	0.152	0.157	0.162	-
B	1.26	1.41	1.56	0.049	0.055	0.061	-
C	-	0.10	-	-	0.004	-	-
D	-	1.90	-	-	0.075	-	-
D1	-	1.90	-	-	0.075	-	-
E	0.35	0.40	0.45	0.013	0.015	0.017	-
E1	0.35	0.40	0.45	0.013	0.015	0.017	-
G	0.85 BSC			0.033 BSC			-
H	-	1.00	-	-	0.039	-	-
H1	-	3.80	-	-	0.149	-	-
H2	-	2.00	-	-	0.078	-	-

NOTES:

1. CONTROLLING DIMENSIONS: MILLIMETERS
2. UNLESS SPECIFIED TOLERANCE=±0.076[0.003].

Figure 6: M7 Package Outline - 10 Pin 4mm x 4mm Surface Mount Module

NOTES

AWL6152

SUNSTAR微波光电 <http://www.rfoe.net/> TEL:0755-83396822 FAX:0755-83376182 E-MAIL:szss20@163.com

ORDERING INFORMATION

ORDER NUMBER	TEMPERATURE RANGE	PACKAGE DESCRIPTION	COMPONENT PACKAGING
AWL6152M7P8	-25 °C to +85°C	10 Pin 4mm x 4mm Surface Mount Module	2,500 piece Tape and Reel



ANADIGICS, Inc.

141 Mount Bethel Road
Warren, New Jersey 07059, U.S.A.

Tel: +1 (908) 668-5000

Fax: +1 (908) 668-5132

URL: <http://www.anadigics.com>

E-mail: Mktg@anadigics.com

IMPORTANT NOTICE

ANADIGICS, Inc. reserves the right to make changes to its products or to discontinue any product at any time without notice. The product specifications contained in Advanced Product Information sheets and Preliminary Data Sheets are subject to change prior to a product's formal introduction. Information in Data Sheets have been carefully checked and are assumed to be reliable; however, ANADIGICS assumes no responsibilities for inaccuracies. ANADIGICS strongly urges customers to verify that the information they are using is current before placing orders.

WARNING

ANADIGICS products are not intended for use in life support appliances, devices or systems. Use of an ANADIGICS product in any such application without written consent is prohibited.

SUNSTAR射频通信 <http://www.rfoe.net/> TEL:0755-83397033 FAX:0755-83376182 E-MAIL:szss20@163.com

SUNSTAR 商斯达实业集团是集研发、生产、工程、销售、代理经销、技术咨询、信息服务等为一体的高科技企业，是专业高科技电子产品生产厂家，是具有 10 多年历史的专业电子元器件供应商，是中国最早和最大的仓储式连锁规模经营大型综合电子零部件代理分销商之一，是一家专业代理和分销世界各大品牌 IC 芯片和电子元器件的连锁经营综合性国际公司，专业经营进口、国产名厂名牌电子元件，型号、种类齐全。在香港、北京、深圳、上海、西安、成都等全国主要电子市场设有直属分公司和产品展示展销窗口门市部专卖店及代理分销商，已在全国范围内建成强大统一的供货和代理分销网络。我们专业代理经销、开发生产电子元器件、集成电路、传感器、微波光电元器件、工控机/DOC/DOM 电子盘、专用电路、单片机开发、MCU/DSP/ARM/FPGA 软件硬件、二极管、三极管、模块等，是您可靠的一站式现货配套供应商、方案提供商、部件功能模块开发配套商。商斯达实业公司拥有庞大的资料库，有数位毕业于著名高校——有中国电子工业摇篮之称的西安电子科技大学（西军电）并长期从事国防尖端科技研究的高级工程师为您精挑细选、量身订做各种高科技电子元器件，并解决各种技术问题。

微波光电部专业代理经销高频、微波、光纤、光电元器件、组件、部件、模块、整机；电磁兼容元器件、材料、设备；微波 CAD、EDA 软件、开发测试仿真工具；微波、光纤仪器仪表。欢迎国外高科技微波、光纤厂商将优秀产品介绍到中国、共同开拓市场。长期大量现货专业批发高频、微波、卫星、光纤、电视、CATV 器件：晶振、VCO、连接器、PIN 开关、变容二极管、开关二极管、低噪晶体管、功率电阻及电容、放大器、功率管、MMIC、混频器、耦合器、功分器、振荡器、合成器、衰减器、滤波器、隔离器、环行器、移相器、调制解调器；光电子器件和组件：红外发射管、红外接收管、光电开关、光敏管、发光二极管和发光二极管组件、半导体激光二极管和激光器组件、光电探测器和光接收组件、光发射接收模块、光纤激光器和光放大器、光调制器、光开关、DWDM 用光发射和接收器件、用户接入系统光收发器件与模块、光纤连接器、光纤跳线/尾纤、光衰减器、光纤适配器、光隔离器、光耦合器、光环行器、光复用器/转换器；无线收发芯片和模组、蓝牙芯片和模组。

更多产品请看本公司产品专用销售网站：

商斯达中国传感器科技信息网：<http://www.sensor-ic.com/>

商斯达工控安防网：<http://www.pc-ps.net/>

商斯达电子元器件网：<http://www.sunstare.com/>

商斯达微波光电产品网：[HTTP://www.rfoe.net/](http://www.rfoe.net/)

商斯达消费电子产品网：<http://www.icasic.com/>

商斯达实业科技产品网：<http://www.sunstars.cn/> 微波元器件销售热线：

地址：深圳市福田区福华路福庆街鸿图大厦 1602 室

电话：0755-82884100 83397033 83396822 83398585

传真：0755-83376182 (0) 13823648918 MSN: SUNS8888@hotmail.com

邮编：518033 E-mail:szss20@163.com QQ: 195847376

深圳赛格展销部：深圳华强北路赛格电子市场 2583 号 电话：0755-83665529 25059422

技术支持：0755-83394033 13501568376

欢迎索取免费详细资料、设计指南和光盘；产品凡多，未能尽录，欢迎来电查询。

北京分公司：北京海淀区知春路 132 号中发电子大厦 3097 号

TEL: 010-81159046 82615020 13501189838 FAX: 010-62543996

上海分公司：上海市北京东路 668 号上海赛格电子市场 D125 号

TEL: 021-28311762 56703037 13701955389 FAX: 021-56703037

西安分公司：西安高新开发区 20 所(中国电子科技集团导航技术研究所)

西安劳动南路 88 号电子商城二楼 D23 号

TEL: 029-81022619 13072977981 FAX:029-88789382