



# Preliminary RFSP5022

## 5.15-5.85 GHz U-NII Power Amplifier

### Applications

- 802.11a WLAN
- HiperLAN/2 WLAN
- U-NII fixed wireless equipment

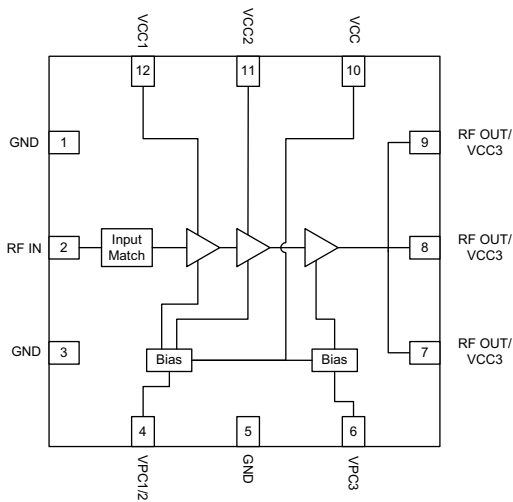

Functional Block Diagram

### Product Description

The RFSP5022 power amplifier is a high-performance GaAs HBT IC designed for use in transmit applications in the 5.15-5.85 GHz frequency band. With a P1dB of 25 dBm, the device is ideal as a final stage for wireless LAN applications requiring high transmit linearity. The part demonstrates very low error vector magnitude (EVM) at the full 54 Mbps data rate for 802.11a. The input of the PA is matched to 50 ohms and the output can be easily matched for optimum linearity and power performance at the desired frequency of operation between 5.15 and 5.85 GHz. The part operates off a single +3.3V supply.

### Product Features

- 25 dBm P1dB@3.3V
- 23 dB gain
- 3.0 % EVM @ P<sub>OUT</sub> = +19 dBm with 54 Mbps OFDM signal
- 175 mA @ P<sub>OUT</sub> = +19 dBm with 54 Mbps OFDM signal
- Single +3.3V supply voltage
- Input matched to 50 ohms
- PA power on/off logic

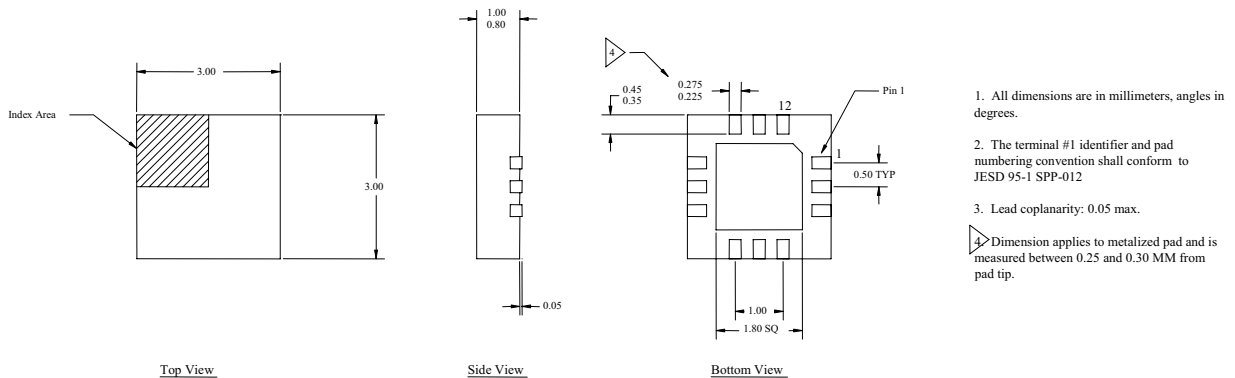

1. All dimensions are in millimeters, angles in degrees.
2. The terminal #1 identifier and pad numbering convention shall conform to JESD 95-1 SPP-012
3. Lead coplanarity: 0.05 max.
4. Dimension applies to metallized pad and is measured between 0.25 and 0.30 mm from pad tip.

3x3 mm Package Outline

## RFSP5022

## 5.15-5.85 GHz U-NII Power Amplifier

Parameter <sup>1</sup>	Specification			Unit	Condition
	Min.	Typ.	Max.		
Overall					
Frequency Range	5150		5850	MHz	
Output P1dB		25		dBm	
Gain		23		dB	P <sub>OUT</sub> = +19 dBm
Error Vector Magnitude (EVM) <sup>2</sup>		3.0		%	P <sub>OUT</sub> = +19 dBm; 54 Mbps OFDM signal
Gain Flatness		±0.5		dB	Across 200 MHz Band
Harmonics					
2 <sup>nd</sup> Harmonic		-30		dBc	@ P1dB
3 <sup>rd</sup> Harmonic		-30		dBc	@ P1dB
Spurious (Stability) <sup>3</sup>		-60		dBc/30 kHz	P <sub>OUT</sub> = -20 dBm to P1dB
Reverse Isolation		35		dB	
Noise Figure		7.5		dB	
Input Return Loss		8		dB	
Output Return Loss		11		dB	With matching capacitor
Power Supply					
Operating Voltage		3.3		V	
Current Consumption		175		mA	P <sub>OUT</sub> = +19 dBm; 54 Mbps OFDM signal
Shutdown Control					
Device On Logic High		3.3		V	
Device Off Logic Low			0.7	V	
Device Off Current			1	uA	
Turn-On Time			500	ns	With 50Ω source
Turn-Off Time			500	ns	With 50Ω source

Note 1: Test Conditions: V<sub>CC</sub> = 3.3V, Freq. = 5250 MHz, T = 25°C, Small Signal Conditions unless otherwise stated.

Note 2: Measured EVM with 1.2% EVM floor.

Note 3: Load VSWR is set to 7:1 and the angle is varied 360 degrees.

## Absolute Maximum Ratings

Parameter	Rating	Unit
DC Power Supply	6.0	V
DC Supply Current	500	mA
Maximum RF input level	+6	dBm
Operating Ambient Temperature	-40 to +85	°C
Storage Temperature	-55 to +150	°C



## Ordering Information

Part Number	Temp. Range (°C)	Package Description	Quantity
PRFS-P5022-EVL	-40 to +85	Evaluation Board	1
PRFS-P5022-005	-40 to +85	13" Reverse Tape/Reel	2500 pcs.
PRFS-P5022-006	-40 to +85	13" Tape/Reel	2500 pcs.
PRFS-P5022-007	-40 to +85	7" Reverse Tape/Reel	1000 pcs.
PRFS-P5022-008	-40 to +85	7" Tape/Reel	1000 pcs.
PRFS-P5022-009	-40 to +85	Bulk – 4x4 mm 24-pin LPCC	1-999 pcs.

**NOTES**

SUNSTAR微波光电 <http://www.rfoe.net/> TEL:0755-83396822 FAX:0755-83376182 E-MAIL:szss20@163.com



**ANADIGICS, Inc.**

141 Mount Bethel Road  
Warren, New Jersey 07059, U.S.A.  
Tel: +1(908)668-5000  
Fax: +1(908)668-5132

URL: <http://www.anadigics.com>  
E-mail: [Mktg@anadigics.com](mailto:Mktg@anadigics.com)

**IMPORTANT NOTICE**

ANADIGICS, Inc. reserves the right to make changes to its products or to discontinue any product at any time without notice. The product specifications contained in Advanced Product Information sheets and Preliminary Data Sheets are subject to change prior to a product's formal introduction. Information in Data Sheets have been carefully checked and are assumed to be reliable; however, ANADIGICS assumes no responsibilities for inaccuracies. ANADIGICS strongly urges customers to verify that the information they are using is current before placing orders.

**WARNING**

ANADIGICS products are not intended for use in life support appliances, devices or systems. Use of an ANADIGICS product in any such application without written consent is prohibited.

SUNSTAR 商斯达实业集团是集研发、生产、工程、销售、代理经销、技术咨询、信息服务等为一体的高科技企业，是专业高科技电子产品生产厂家，是具有 10 多年历史的专业电子元器件供应商，是中国最早和最大的仓储式连锁规模经营大型综合电子零部件代理分销商之一，是一家专业代理和分销世界各大品牌 IC 芯片和电子元器件的连锁经营综合性国际公司，专业经营进口、国产名厂名牌电子元件，型号、种类齐全。在香港、北京、深圳、上海、西安、成都等全国主要电子市场设有直属分公司和产品展示展销窗口门市部专卖店及代理分销商，已在全国范围内建成强大统一的供货和代理分销网络。我们专业代理经销、开发生产电子元器件、集成电路、传感器、微波光电元器件、工控机/DOC/DOM 电子盘、专用电路、单片机开发、MCU/DSP/ARM/FPGA 软件硬件、二极管、三极管、模块等，是您可靠的一站式现货配套供应商、方案提供商、部件功能模块开发配套商。商斯达实业公司拥有庞大的资料库，有数位毕业于著名高校——有中国电子工业摇篮之称的西安电子科技大学（西军电）并长期从事国防尖端科技研究的高级工程师为您精挑细选、量身订做各种高科技电子元器件，并解决各种技术问题。

微波光电部专业代理经销高频、微波、光纤、光电元器件、组件、部件、模块、整机；电磁兼容元器件、材料、设备；微波 CAD、EDA 软件、开发测试仿真工具；微波、光纤仪器仪表。欢迎国外高科技微波、光纤厂商将优秀产品介绍到中国、共同开拓市场。长期大量现货专业批发高频、微波、卫星、光纤、电视、CATV 器件：晶振、VCO、连接器、PIN 开关、变容二极管、开关二极管、低噪晶体管、功率电阻及电容、放大器、功率管、MMIC、混频器、耦合器、功分器、振荡器、合成器、衰减器、滤波器、隔离器、环行器、移相器、调制解调器；光电子器件和组件：红外发射管、红外接收管、光电开关、光敏管、发光二极管和发光二极管组件、半导体激光二极管和激光器组件、光电探测器和光接收组件、光发射接收模块、光纤激光器和光放大器、光调制器、光开关、DWDM 用光发射和接收器件、用户接入系统光收发器件与模块、光纤连接器、光纤跳线/尾纤、光衰减器、光纤适配器、光隔离器、光耦合器、光环行器、光复用器/转换器；无线收发芯片和模组、蓝牙芯片和模组。

更多产品请看本公司产品专用销售网站：

商斯达中国传感器科技信息网：<http://www.sensor-ic.com/>

商斯达工控安防网：<http://www.pc-ps.net/>

商斯达电子元器件网：<http://www.sunstare.com/>

商斯达微波光电产品网：[HTTP://www.rfoe.net/](http://www.rfoe.net/)

商斯达消费电子产品网：<http://www.icasic.com/>

商斯达实业科技产品网：<http://www.sunstars.cn/> 微波元器件销售热线：

地址：深圳市福田区福华路福庆街鸿图大厦 1602 室

电话：0755-82884100 83397033 83396822 83398585

传真：0755-83376182 (0) 13823648918 MSN: SUNS8888@hotmail.com

邮编：518033 E-mail:szss20@163.com QQ: 195847376

深圳赛格展销部：深圳华强北路赛格电子市场 2583 号 电话：0755-83665529 25059422

技术支持：0755-83394033 13501568376

欢迎索取免费详细资料、设计指南和光盘；产品凡多，未能尽录，欢迎来电查询。

北京分公司：北京海淀区知春路 132 号中发电子大厦 3097 号

TEL: 010-81159046 82615020 13501189838 FAX: 010-62543996

上海分公司：上海市北京东路 668 号上海赛格电子市场 D125 号

TEL: 021-28311762 56703037 13701955389 FAX: 021-56703037

西安分公司：西安高新开发区 20 所(中国电子科技集团导航技术研究所)

西安劳动南路 88 号电子商城二楼 D23 号

TEL: 029-81022619 13072977981 FAX:029-88789382