

AC/DC to Logic Interface Hermetically Sealed Optocouplers

Technical Data

HCPL-576X*

5962-8947701

*See matrix for available extensions

Features

- Dual Marked with Device Part Number and DSCC Standard Microcircuit Drawing
- Manufactured and Tested on a MIL-PRF-38534 Certified Line
- QML-38534, Class H and K
- Hermetically Sealed 8-pin Dual In-Line Packages
- Performance Guaranteed over -55°C to +125°C
- ac or dc Input
- Programmable Sense Voltage
- Hysteresis
- HCPL-3700 Operating Compatibility
- Logic Compatible Output
- 1500 Vdc Withstand Test Voltage
- Thresholds Guaranteed over Temperature
- Thresholds Independent of LED Characteristics

Applications

- Military and Space
- High Reliability Systems
- Transportation, Medical, and Life Critical Systems
- Limit Switch Sensing
- Low Voltage Detector
- ac/dc Voltage Sensing
- Relay Contact Monitor
- Relay Coil Voltage Monitor
- Current Sensing
- Microprocessor Interface
- Telephone Ring Detection
- Harsh Industrial Environments

Description

These devices are single channel, hermetically sealed, voltage/current threshold detection optocouplers. The products are capable of operation and storage over the full military temperature range and can be purchased as either standard product, or with full MIL-PRF-38534 Class Level H or K testing, or from the DSCC Standard Microcircuit Drawing (SMD) 5962-89477. All devices are manufactured and tested on a MIL-PRF-38534 certified line and are included in the DSCC Qualified Manufacturers List, QML-38534 for Hybrid Microcircuits.

Schematic

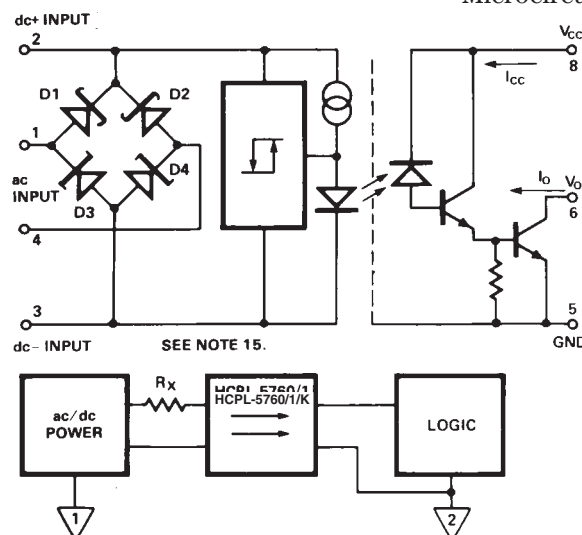

TRUTH TABLE

INPUT	OUTPUT
H($V_{TH} < V_{dc}(on)$)	L
L($V_{dc} < V_{TH}(off)$)	H

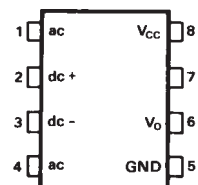

The connection of a 0.1 μ F bypass capacitor between pins 8 and 5 is recommended.

CAUTION: It is advised that normal static precautions be taken in handling and assembly of this component to prevent damage and/or degradation which may be induced by ESD.

Each unit contains a light emitting diode (LED), a threshold sensing input buffer IC, and a high gain photon detector to provide an optocoupler which permits adjustable external threshold levels. The input buffer circuit has a nominal turn on threshold of 2.5 mA (I_{TH+}) and 3.6 volts (V_{TH+}). The addition of one or more external attenuation resistors permits the use of this device over a wide range of input voltages and currents. Threshold sensing prior to the LED and detector elements minimizes effects of any variation in optical

coupling. Hysteresis is also provided in the buffer for extra noise immunity and switching stability.

The buffer circuit is designed with internal clamping diodes to protect the circuitry and LED from a wide range of over-voltage and over-current transients while the diode bridge enables easy use with ac voltage input.

These units combine several unique functions in a single package, providing the user with an ideal component for computer

input boards and other applications where a predetermined input threshold optocoupler level is desirable.

The high gain output stage features an open collector output providing both TTL compatible saturation voltages and CMOS compatible breakdown voltages.

This is an eight pin DIP which may be purchased with a variety of lead bend and plating options. See Selection Guide Table for details. Standard Microcircuit Drawing (SMD) parts are available for each lead style.

Selection Guide—Package Styles and Lead Configuration Options

Agilent Part # and Options	
Commercial	HCPL-5760
MIL-PRF-38534 Class H	HCPL-5761
MIL-PRF-38534 Class K	HCPL-576K
Standard Lead Finish	Gold
Solder Dipped	Option #200
Butt Joint/Gold Plate	Option #100
Gull Wing/Soldered	Option #300
Crew Cut/Gold Plate	Option #600
Class H SMD Part #	
Prescript for all below	5962-
Either Gold or Soldered	8947701PX
Gold Plate	8947701PC
Solder Dipped	8947701PA
Butt Joint/Gold Plate	8947701YC
Butt Joint/Soldered	8947701YA
Gull Wing/Soldered	8947701XA
Crew Cut/Gold Plate	Available
Crew Cut/Soldered	Available
Class K SMD Part #	
Prescript for all below	5962-
Either Gold or Soldered	8947702KPX
Gold Plate	8947702KPC
Solder Dipped	8947702KPA
Butt Joint/Gold Plate	8947702KYC
Butt Joint/Soldered	8947702KYA
Gull Wing/Soldered	8947702KXA
Crew Cut/Gold Plate	Available
Crew Cut/Soldered	Available

Absolute Maximum Ratings

Storage Temperature Range	-65°C to +150°C
Operating Temperature	-55°C to 125°C
Lead Solder Temperature	260°C for 10 s ^[2]
Average Input Current, I _{IN}	15 mA ^[3]
Surge Input Current, I _{IN,SG}	140 mA ^[3,4]
Peak Transient Input Current, I _{IN,PK}	500 mA ^[3,4]
Input Power Dissipation, P _{IN}	195 mW ^[5]
Total Package Power Dissipation, P _d	260 mW
Output Power Dissipation, P _O	65 mW
Average Output Current, I _O	40 mA
Supply Voltage, V _{CC} (Pins 8-5)	-0.5 min., 20 V max.
Output Voltage, V _O (Pins 6-5)	-0.5 min., 20 V max.

ESD Classification

(MIL-STD-883, Method 3015) (ΔΔ), Class 2

Recommended Operating Conditions

Parameter	Symbol	Min.	Max.	Units
Power Supply	V _{CC}	3.0	18	V
Operating Frequency ^[1]	f	0	10	KHz

Outline Drawing

8 Pin DIP Through Hole

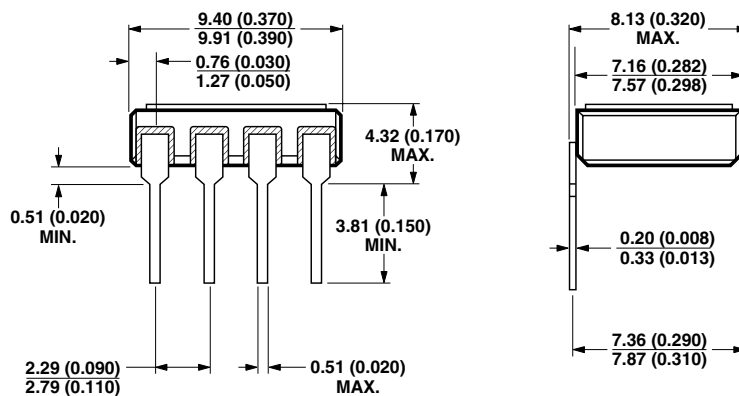

NOTE: DIMENSIONS IN MILLIMETERS (INCHES).

Device Marking

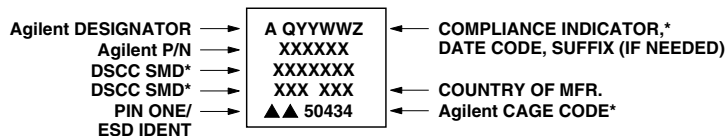

* QUALIFIED PARTS ONLY

Hermetic Optocoupler Options

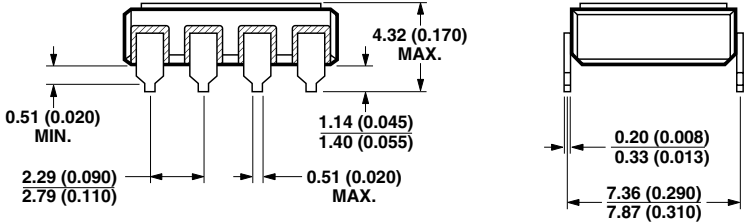
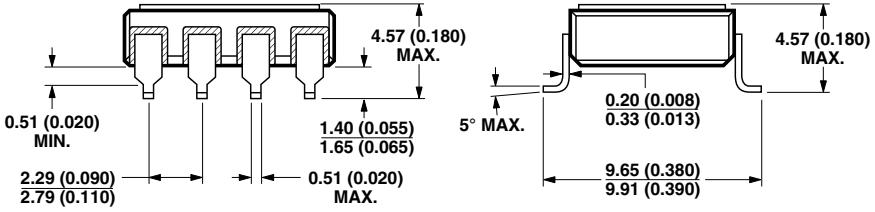
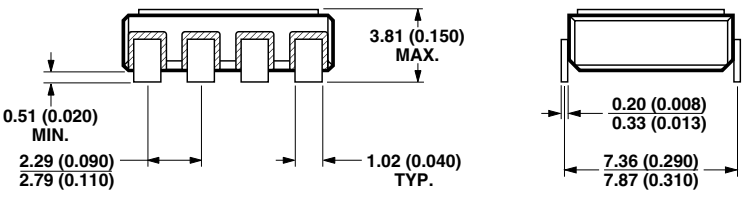
Option	Description
100	<p>Surface mountable hermetic optocoupler with leads trimmed for butt joint assembly. This option is available on commercial and hi-rel product.</p> 
200	<p>Lead finish is solder dipped rather than gold plated. This option is available on commercial and hi-rel product. DSCC Drawing part numbers contain provisions for lead finish.</p>
300	<p>Surface mountable hermetic optocoupler with leads cut and bent for gull wing assembly. This option is available on commercial and hi-rel product. This option has solder dipped leads.</p> 
600	<p>Surface mountable hermetic optocoupler with leads trimmed for butt joint assembly. This option is available on commercial and hi-rel product. Contact factory for the availability of this option on DSCC part types.</p> 

Note: Dimensions in millimeters (inches).

Electrical Characteristics $T_A = -55^\circ\text{C}$ to 125°C , unless otherwise specified. See note 16.

Parameter		Symbol	Conditions	Group A Subgroup	Min.	Typ.*	Max.	Units	Fig.	Note
Input Threshold Current		I_{TH+}	$V_{IN} = V_{TH+}; V_{CC} = 4.5\text{ V}; V_O = 0.4\text{ V}; I_O \geq 2.6\text{ mA}$	1, 2, 3	1.75	2.5	3.20	mA		
		I_{TH-}	$V_{IN} = V_{TH-}; V_{CC} = 4.5\text{ V}; V_O = 2.4\text{ V}; I_{OH} \leq 250\text{ }\mu\text{A}$	1, 2, 3	0.93	1.3	1.62	mA		
Input Threshold Voltage	dc (Pins 2, 3)	V_{TH+}	$V_{IN} = V_2 - V_3$; Pins 1 & 4 Open $V_{CC} = 4.5\text{ V}; V_O = 0.4\text{ V}; I_O \geq 2.6\text{ mA}$	1, 2, 3	3.18	3.6	4.10	V	1, 2	7
		V_{TH-}	$V_{IN} = V_2 - V_3$; Pins 1 & 4 Open $V_{CC} = 4.5\text{ V}; V_O = 2.4\text{ V}; I_O \leq 250\text{ }\mu\text{A}$	1, 2, 3	1.90	2.5	3.00	V		
	ac (Pins 1, 4)	V_{TH+}	$V_{IN} = V_1 - V_4 $; Pins 2 & 3 Open $V_{CC} = 4.5\text{ V}; V_O = 0.4\text{ V}; I_O \geq 2.6\text{ mA}$	1, 2, 3	3.79	5.0	5.62	V		7, 8
		V_{TH-}	$V_{IN} = V_1 - V_4 $; Pins 2 & 3 Open $V_{CC} = 4.5\text{ V}; V_O = 2.4\text{ V}; I_O \leq 250\text{ }\mu\text{A}$	1, 2, 3	2.57	3.7	4.52	V		
Input Clamp Voltage		V_{IHC1}	$V_{IHC1} = V_2 - V_3$; $V_3 = \text{GND}$; $I_{IN} = 10\text{ mA}$; Pin 1 & 4 Connected to Pin 3	1, 2, 3	5.3	5.9	7.5	V	3	15
		V_{IHC2}	$V_{IHC2} = V_1 - V_4 $; $ I_{IN} = 10\text{ mA}$; Pins 2 & 3 Open	1, 2, 3	6.0	6.6	8.0	V		
		V_{IHC3}	$V_{IHC3} = V_2 - V_3$; $V_3 = \text{GND}$; $I_{IN} = 13.5\text{ mA}$; Pins 1 & 4 Open	1, 2, 3		12.0	14.0	V		
Input Current		I_{IN}	$V_{IN} = V_2 - V_3 = 5.0\text{ V}$; Pins 1 & 4 Open	1, 2, 3	3.0	3.9	4.5	mA	4	
Logic Low Output Voltage		V_{OL}	$V_{CC} = 4.5\text{ V}$; $I_{OL} = 2.6\text{ mA}$	1, 2, 3		0.05	0.4	V	4	
Logic High Output Current		I_{OH}	$V_{OH} = V_{CC} = 18\text{ V}$	1, 2, 3			250	μA		7
Logic Low Supply Current		I_{CCL}	$V_2 - V_3 = 5.0\text{ V}$; $V_O = \text{Open}$; $V_{CC} = 18\text{ V}$	1, 2, 3		0.8	3.0	mA		
Logic High Supply Current		I_{CCH}	$V_{CC} = 18\text{ V}$; $V_O = \text{Open}$	1, 2, 3		0.001	20	μA	5	
Input-Output Insulation		I_{I-O}	45% RH, $t = 5\text{ s}$; $V_{I-O} = 1500\text{ Vdc}$; $T_A = 25^\circ\text{C}$	1			1	μA		9, 10

Electrical Characteristics $T_A = -55^{\circ}\text{C}$ to 125°C , $V_{CC} = 5.0\text{ V}$, unless otherwise specified (continued).

Parameter	Symbol	Conditions	Group A Subgroup	Min.	Typ.*	Max.	Units	Fig.	Note
Propagation Delay Time to Logic Low Output Level	t_{PHL}	$R_L = 1.8\text{ k}\Omega$, $C_L = 15\text{ pF}$	9, 10, 11		4	20	μs	6, 7	6, 11
Propagation Delay Time to Logic High Output Level	t_{PLH}	$R_L = 1.8\text{ k}\Omega$, $C_L = 15\text{ pF}$	9, 10, 11		8	40	μs		6, 12
Logic High Common Mode Transient Immunity	$ CM_H $	$V_{CM} = 50\text{ V}$	$T_A = 25^{\circ}\text{C}$ $I_{IN} = 0\text{ mA}$	9	1000	$\geq 10,000$	$\text{V}/\mu\text{s}$	8	13, 14, 17
		$V_{CM} = 450\text{ V}$			$\geq 10,000$				
Logic Low Common Mode Transient Immunity	$ CM_L $	$V_{CM} = 50\text{ V}$	$T_A = 25^{\circ}\text{C}$ $I_{IN} = 4\text{ mA}$	9	1000	$\geq 5,000$	$\text{V}/\mu\text{s}$		
		$V_{CM} = 250\text{ V}$			$\geq 5,000$				

*All typical values are at $T_A = 25^{\circ}\text{C}$, $V_{CC} = 5\text{ V}$ unless otherwise noted.

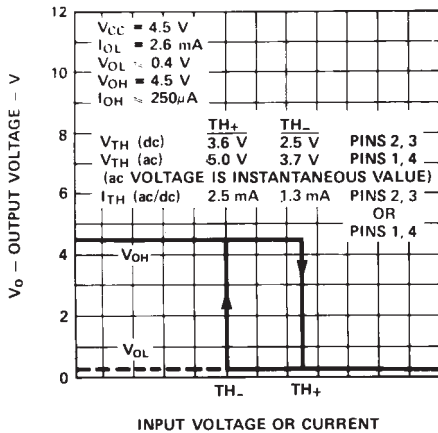

Figure 1. Typical Transfer Characteristics.

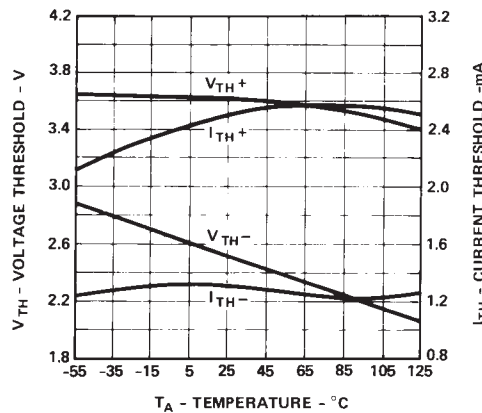

Figure 2. Typical dc Threshold Levels vs. Temperature.

Typical Characteristics All typical values are at $T_A = 25^\circ\text{C}$, $V_{CC} = 5\text{ V}$, unless otherwise specified.

Parameter	Symbol	Typ.	Units	Conditions	Fig.	Note
Hysteresis	I_{HYS}	1.2	mA	$I_{\text{HYS}} = I_{\text{TH+}} - I_{\text{TH-}}$	1	
	V_{HYS}	1.1	V	$V_{\text{HYS}} = V_{\text{TH+}} - V_{\text{TH-}}$		
Input Clamp Voltage	V_{ILC}	-0.76	V	$V_{\text{ILC}} = V_2 - V_3$; $V_3 = \text{GND}$; $I_{\text{IN}} = -10\text{ mA}$		
Bridge Diode Forward Voltage	$V_{\text{D1,2}}$	0.62		$I_{\text{IN}} = 3\text{ mA}$ (see schematic)		
	$V_{\text{D3,4}}$	0.73				
Input-Output Resistance	$R_{\text{I/O}}$	10^{12}	Ω	$V_{\text{I/O}} = 500\text{ Vdc}$		9
Input-Output Capacitance	$C_{\text{I/O}}$	2.0	pF	$f = 1\text{ MHz}$, $V_{\text{I/O}} = 0\text{ Vdc}$		
Input Capacitance	C_{IN}	50	pF	$f = 1\text{ MHz}$; $V_{\text{IN}} = 0\text{ V}$, Pins 2 & 3, Pins 1 & 4 Open		
Output Rise Time (10-90%)	t_r	10	μs		7	
Output Fall Time (90-10%)	t_f	0.5	μs		7	

Notes:

- Maximum operating frequency is defined when output waveform (Pin 6) attains only 90% of V_{CC} with $R_L = 1.8\text{ k}\Omega$, $C_L = 15\text{ pF}$ using a 5 V square wave input signal.
- Measured at a point 1.6 mm below seating plane.
- Current into/out of any single lead.
- Surge input current duration is 3 ms at 120 Hz pulse repetition rate. Transient input current duration is 10 μs at 120 Hz pulse repetition rate. Note that maximum input power, P_{IN} , must be observed.
- Derate linearly above 100°C free-air temperature at a rate of 4.26 mW/°C. Maximum input power dissipation of 195 mW allows an input IC junction temperature of 150°C at an ambient temperature of $T_A = 125^\circ\text{C}$ with a typical thermal resistance from junction to ambient of $\theta_{\text{JAi}} = 235^\circ\text{C/W}$. The typical thermal resistance from junction to case is equal to 170°C/W. Excessive P_{IN} and T_J may result in device degradation.
- The 1.8 k Ω load represents 1 TTL unit load of 1.6 mA and the 4.7 k Ω pull-up resistor.
- Logic low output level at Pin 6 occurs under the conditions of $V_{\text{IN}} \geq V_{\text{TH+}}$ as well as the range of $V_{\text{IN}} > V_{\text{TH-}}$ once V_{IN} has exceeded $V_{\text{TH+}}$. Logic high output level at Pin 6 occurs under the conditions of $V_{\text{IN}} \leq V_{\text{TH-}}$ as well as the range of $V_{\text{IN}} < V_{\text{TH+}}$ once V_{IN} has decreased below $V_{\text{TH-}}$.
- The ac voltage is instantaneous voltage.
- Device considered a two terminal device: Pins 1, 2, 3, 4 connected together, Pins 5, 6, 7, 8 connected together.
- This is a momentary withstand test, not an operating condition.
- The t_{PHL} propagation delay is measured from the 2.5 V level of the leading edge of a 5.0 V input pulse (1 μs rise time) to the 1.5 V level on the leading edge of the output pulse (see Figure 7).
- The t_{PLH} propagation delay is measured from the 2.5 V level of the trailing edge of a 5.0 V input pulse (1 μs fall time) to the 1.5 V level on the trailing edge of the output pulse (see Figure 7).
- Common mode transient immunity in Logic High level is the maximum tolerable $dV_{\text{CM/dt}}$ of the common mode voltage, V_{CM} , to ensure that the output will remain in a Logic High state (i.e., $V_O > 2.0\text{ V}$). Common mode transient immunity in Logic Low level is the maximum tolerable $dV_{\text{CM/dt}}$ of the common mode voltage, V_{CM} , to ensure that the output will remain in a Logic Low state (i.e., $V_O < 0.8\text{ V}$). See Figure 8.
- In applications where $dV_{\text{CM/dt}}$ may exceed 50,000 V/ μs (such as static discharge), a series resistor, R_{CC} , should be included to protect the detector IC from destructively high surge currents. The recommended value for R_{CC} is 240 Ω per volt of allowable drop in V_{CC} (between Pin 8 and V_{CC}) with a minimum value of 240 Ω .
- D_1 and D_2 are Schottky diodes; D_3 and D_4 are zener diodes.
- Standard parts receive 100% testing at 25°C (Subgroups 1 and 9). SMD, Class H and Class K parts receive 100% testing at 25, 125, and -55°C (Subgroups 1 and 9, 2 and 10, 3 and 11, respectively.)
- Parameters shall be tested as part of device initial characterization and after process changes. Parameters shall be guaranteed to the limits specified for all lots not specifically tested.

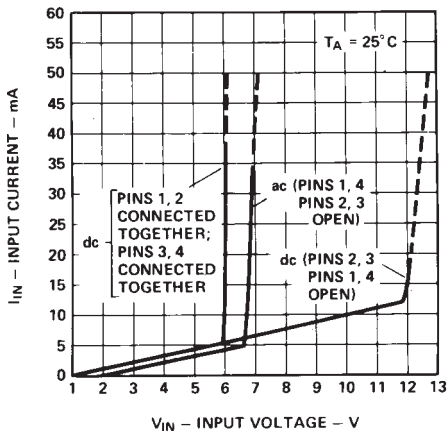

Figure 3. Typical Input Characteristics, I_{IN} vs. V_{IN} . (AC Voltage is Instantaneous Value.)

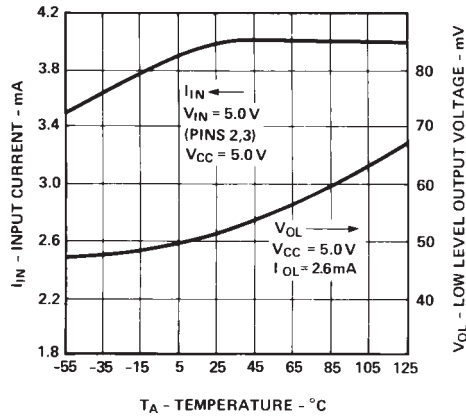

Figure 4. Typical Input Current, I_{IN} , and Low Level Output Voltage, V_{OL} , vs. Temperature.

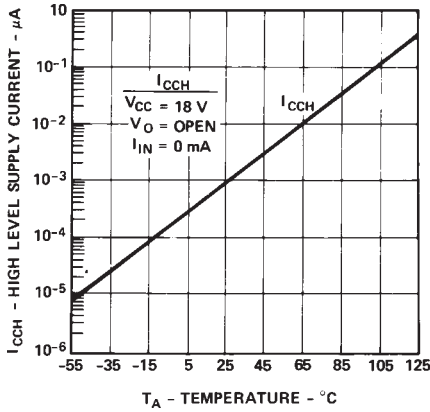

Figure 5. Typical High Level Supply Current, I_{CCH} vs. Temperature.

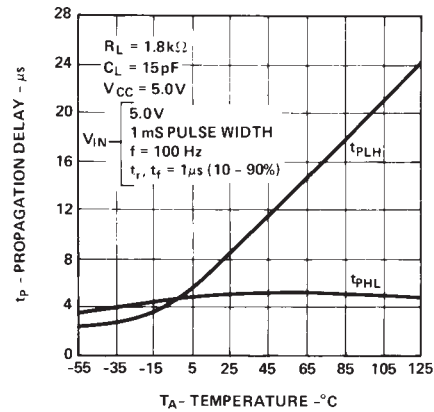

Figure 6. Typical Propagation Delay vs. Temperature.

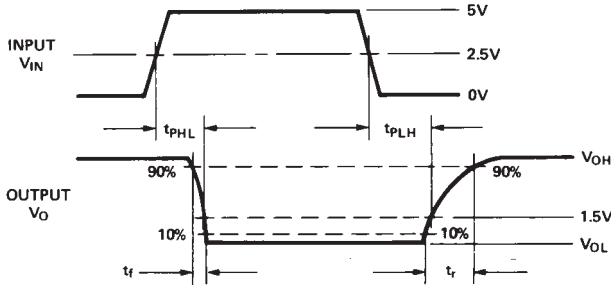
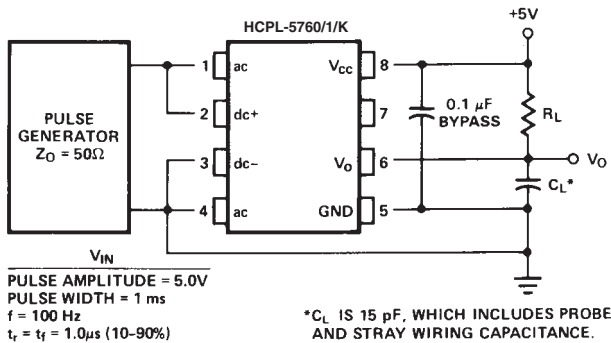

Figure 7. Switching Test Circuit.

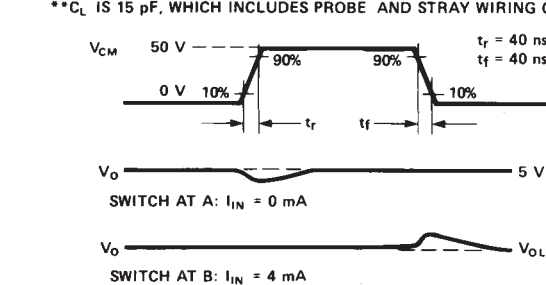
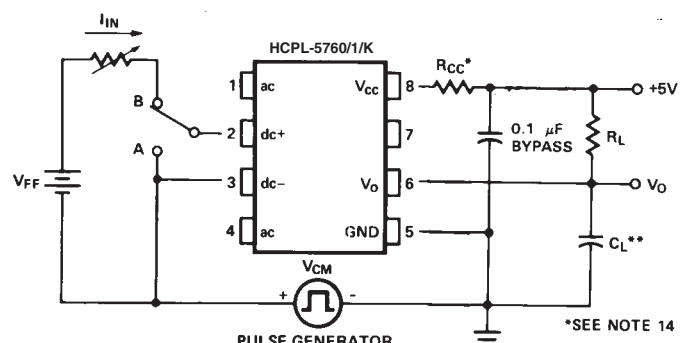

Figure 8. Test Circuit for Common Mode Transient Immunity and Typical Waveforms

Electrical Considerations

The HCPL-5760, HCPL-5761, HCPL-576K or 5962-89477 optocoupler has internal temperature compensated, predictable voltage and current threshold points which allow selection of an external resistor, R_x , to determine larger external threshold voltage levels. For a desired external threshold voltage, V_{\pm} , a corresponding typical value of R_x can be obtained from Figure 10. Specific calculation of R_x can be obtained from Equation (1) of Figure 11. Specification of both V_+ and V_- voltage threshold levels simultaneously can be obtained by the use of R_x and R_p as shown in Figure 11 and determined by Equations (2) and (3).

R_x can provide over-current transient protection by limiting input current during a transient condition. For monitoring contacts with a relay or switch, the HCPL-5760/1/K, or 5962-89477 combination with R_x and R_p can be used to allow a specific current to be conducted through the contacts for cleaning purposes (wetting current).

The choice of which input voltage clamp level to choose depends upon the application of this device (see Figure 3). It is recommended that the low clamp condition be used when possible to lower the input power dissipation as well as the LED current, which minimizes LED degradation over time.

In applications where dV_{CM}/dt may be extremely large (such as static discharge), a series resistor, R_{CC} , should be connected in series with V_{CC} and Pin 8 to protect the

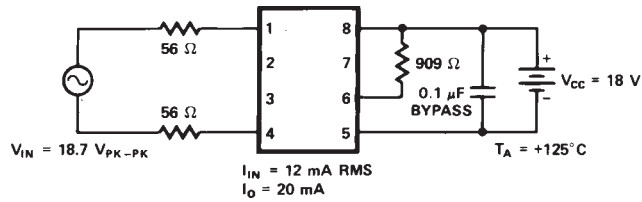

Figure 9. Operating Circuit for Burn-In and Steady State Life Tests.

detector IC from destructively high surge currents. See note 14 for determination of R_{CC} . In addition, it is recommended that a ceramic disc bypass capacitor of 0.01 μF to 0.1 μF be placed between Pins 8 and 5 to reduce the effect of power supply noise.

For interfacing ac signals to TTL systems, output low pass filtering can be performed with a pullup resistor of 1.5 k Ω and 20 μF capacitor. This application requires a Schmitt trigger gate to avoid slow rise time chatter problems. For ac input applications, a filter capacitor can be placed across the dc input terminals for either signal or transient filtering.

Either ac (Pins 1, 4) or dc (Pins 2, 3) input can be used to determine external threshold levels.

For one specifically selected external threshold voltage level V_+ or V_- , R_x can be determined without use of R_p via

$$R_x = \frac{V_{\pm} - V_{TH\pm}}{I_{TH\pm}} \quad (1)$$

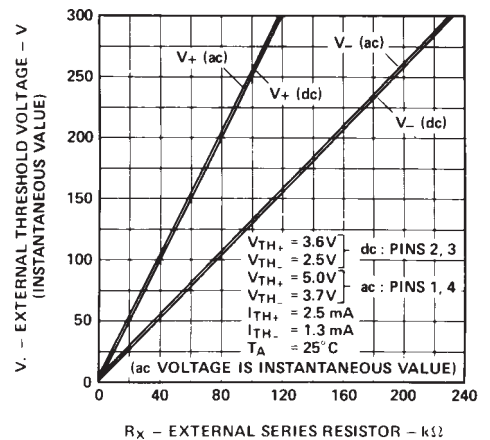

Figure 10. Typical External Threshold Characteristic, V_{\pm} vs. R_x .

For two specifically selected external threshold voltage levels, V_+ and V_- , the use of R_x and R_p will permit this selection via equations (2), (3) provided the following conditions are met:

$$\frac{V_+}{V_-} \geq \frac{V_{TH+}}{V_{TH-}} \text{ and } \frac{V_+ - V_{TH+}}{V_- - V_{TH-}} < \frac{I_{TH+}}{I_{TH-}}$$

$$R_x = \frac{V_{TH-} (V_+) - V_{TH+} (V_-)}{I_{TH+} (V_{TH-}) - I_{TH-} (V_{TH+})} \quad (2)$$

$$R_p = \frac{V_{TH-} (V_+) - V_{TH+} (V_-)}{I_{TH+} (V_- - V_{TH-}) + I_{TH-} (V_{TH+} - V_+)} \quad (3)$$

See Application Note 1004 for more information.

MIL-PRF-38534 Class H, Class K, and DSCC SMD Test Program

Agilent Technologies' Hi-Rel Optocouplers are in compliance with MIL-PRF-38534 Class H and K. Class H and Class K devices are also in compliance with DSCC drawing 5962-89477.

Testing consists of 100% screening and quality conformance inspection to MIL-PRF-38534.

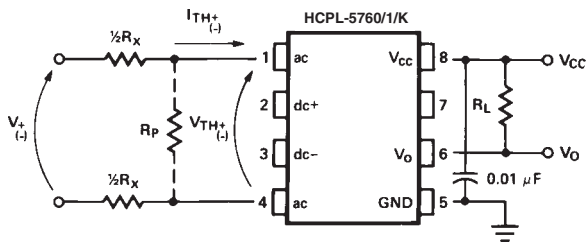

Figure 11. External Threshold Voltage Level Selection.



www.semiconductor.agilent.com

Data subject to change.

Copyright © 2001 Agilent Technologies

August 23, 2001

Obsoletes 5968-9404E (11/00)

5988-3093EN

SUNSTAR 商斯达实业集团是集研发、生产、工程、销售、代理经销、技术咨询、信息服务等为一体的高科技企业，是专业高科技电子产品生产厂家，是具有 10 多年历史的专业电子元器件供应商，是中国最早和最大的仓储式连锁规模经营大型综合电子零部件代理分销商之一，是一家专业代理和分销世界各大品牌 IC 芯片和电子元器件的连锁经营综合性国际公司，专业经营进口、国产名厂名牌电子元件，型号、种类齐全。在香港、北京、深圳、上海、西安、成都等全国主要电子市场设有直属分公司和产品展示展销窗口门市部专卖店及代理分销商，已在全国范围内建成强大统一的供货和代理分销网络。我们专业代理经销、开发生产电子元器件、集成电路、传感器、微波光电元器件、工控机/DOC/DOM 电子盘、专用电路、单片机开发、MCU/DSP/ARM/FPGA 软件硬件、二极管、三极管、模块等，是您可靠的一站式现货配套供应商、方案提供商、部件功能模块开发配套商。商斯达实业公司拥有庞大的资料库，有数位毕业于著名高校——有中国电子工业摇篮之称的西安电子科技大学（西军电）并长期从事国防尖端科技研究的高级工程师为您精挑细选、量身订做各种高科技电子元器件，并解决各种技术问题。

微波光电部专业代理经销高频、微波、光纤、光电元器件、组件、部件、模块、整机；电磁兼容元器件、材料、设备；微波 CAD、EDA 软件、开发测试仿真工具；微波、光纤仪器仪表。欢迎国外高科技微波、光纤厂商将优秀产品介绍到中国、共同开拓市场。长期大量现货专业批发高频、微波、卫星、光纤、电视、CATV 器件：晶振、VCO、连接器、PIN 开关、变容二极管、开关二极管、低噪晶体管、功率电阻及电容、放大器、功率管、MMIC、混频器、耦合器、功分器、振荡器、合成器、衰减器、滤波器、隔离器、环行器、移相器、调制解调器；光电子器件和组件：红外发射管、红外接收管、光电开关、光敏管、发光二极管和发光二极管组件、半导体激光二极管和激光器组件、光电探测器和光接收组件、光发射接收模块、光纤激光器和光放大器、光调制器、光开关、DWDM 用光发射和接收器件、用户接入系统光收发器件与模块、光纤连接器、光纤跳线/尾纤、光衰减器、光纤适配器、光隔离器、光耦合器、光环行器、光复用器/转换器；无线收发芯片和模组、蓝牙芯片和模组。

更多产品请看本公司产品专用销售网站：

商斯达微波光电产品网：[HTTP://www.rfoe.net/](http://www.rfoe.net/)

商斯达中国传感器科技信息网：<http://www.sensor-ic.com/>

商斯达工控安防网：<http://www.pc-ps.net/>

商斯达电子元器件网：<http://www.sunstare.com/>

商斯达消费电子产品网：<http://www.icasic.com/>

商斯达实业科技产品网：<http://www.sunstars.cn/> 射频微波光电元器件销售热线：

地址：深圳市福田区福华路福庆街鸿图大厦 1602 室

电话：0755-83396822 83397033 83398585 82884100

传真：0755-83376182 (0) 13823648918 MSN: SUNS8888@hotmail.com

邮编：518033 E-mail:szss20@163.com QQ: 195847376

深圳赛格展销部：深圳华强北路赛格电子市场 2583 号 电话：0755-83665529 25059422

技术支持：0755-83394033 13501568376

欢迎索取免费详细资料、设计指南和光盘；产品凡多，未能尽录，欢迎来电查询。

北京分公司：北京海淀区知春路 132 号中发电子大厦 3097 号

TEL: 010-81159046 82615020 13501189838 FAX: 010-62543996

上海分公司：上海市北京东路 668 号上海赛格电子市场 D125 号

TEL: 021-28311762 56703037 13701955389 FAX: 021-56703037

西安分公司：西安高新开发区 20 所(中国电子科技集团导航技术研究所)

西安劳动南路 88 号电子商城二楼 D23 号

TEL: 029-81022619 13072977981 FAX:029-88789382