



Designing with Agilent Technologies Isolation Amplifiers

Application Note 1078

Introduction

One of the more difficult problems that designers may face is trying to isolate precision analog signals in an extremely noisy environment. A good example is monitoring the motor phase current in a high-performance motor drive. A typical three-phase induction motor drive, shown in Figure 1,

first rectifies and filters the three-phase AC line voltage to obtain a high-voltage DC power supply; the output transistors then invert the DC supply voltage back into an AC signal to drive the three-phase induction motor. The motor drive commonly uses pulse-width modulation (PWM) to generate a variable voltage, variable fre-

quency drive signal for the motor. High performance motor drives usually incorporate some form of current sensing in their design. The difficulty in isolating precision analog signals arises from the large voltage transients that are generated by the

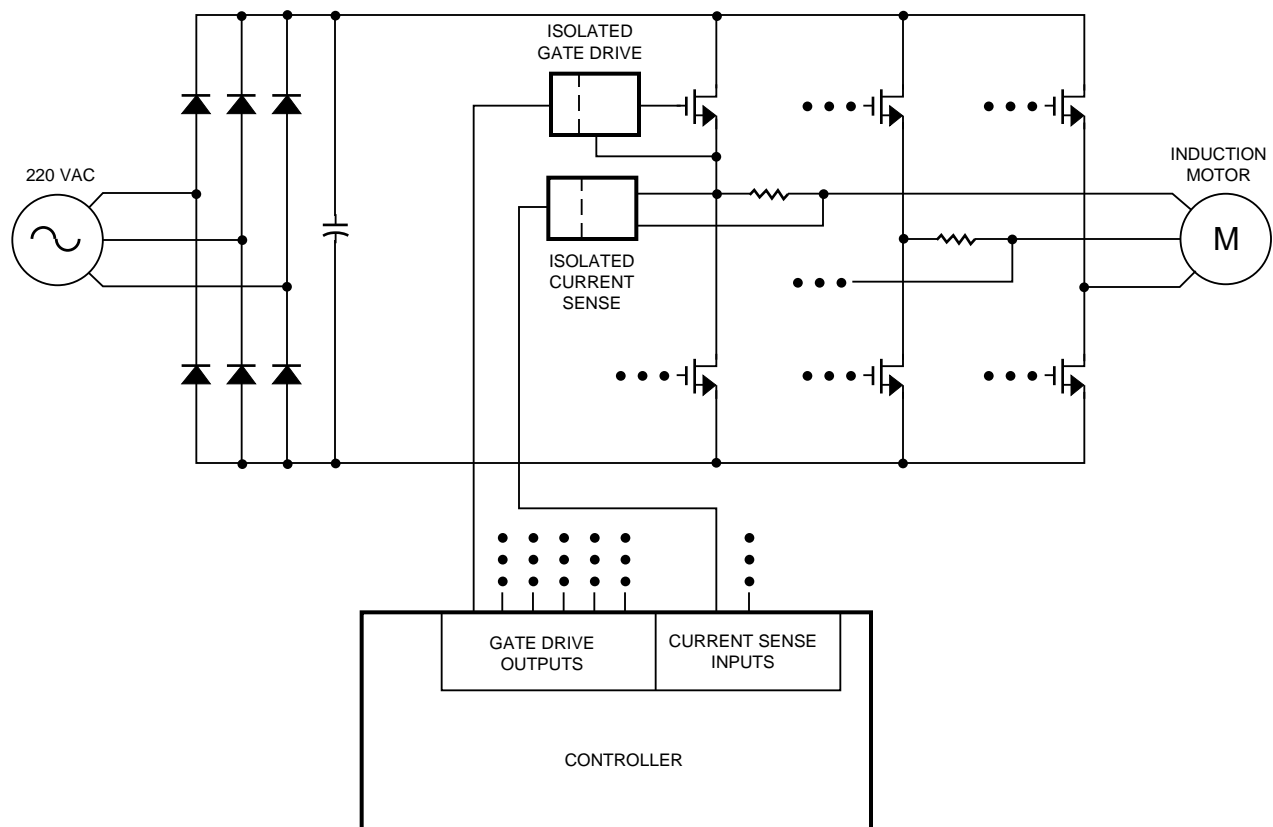

Figure 1. Typical Three-Phase AC Induction Motor Drive.

switching of the inverter transistors. These very large transients (at least equal in amplitude to the DC supply voltage) can exhibit extremely fast rates of rise (greater than 10 kV/ μ s), making it extremely difficult to sense the current flowing through each of the motor phases.

Agilent Technologies' line of isolation amplifiers was specifically developed as a compact low-cost solution for just this type of design problem; these isolation amplifiers allow designers to sense current in extremely noisy environments while maintaining excellent gain and offset accuracy. They exhibit outstanding stability over both time and temperature, as well as unequaled common-mode transient noise rejection (CMR). The small input voltage range helps minimize power dissipation in the current-sensing resistor (current shunt), and both positive and negative input voltages can be sensed with only a single +5V input power supply.

Compared to Hall-effect sensors, another commonly used current-sensing device, Agilent's isolation amplifiers have excellent gain and offset characteristics, including

very low drift over temperature. In addition, they exhibit superior common-mode transient noise immunity, are not affected by external magnetic fields, and do not exhibit residual magnetization effects that can affect offset. They are also easily mounted on a printed circuit board and are very flexible for designers to use. This flexibility allows the same circuit and layout to be used to sense different current ranges simply by substituting different current-sensing resistors. These features make the Agilent line of isolation amplifiers an excellent choice for sensing current in many different applications.

Functional Description

Figure 2 shows the primary functional blocks of the HCPL-7820, a representative Agilent isolation amplifier. In operation, the sigma-delta modulator converts the analog input signal into a high-speed serial bit stream; the time average of the bit stream is directly proportional to the input signal, as shown in Figure 3. This high-speed stream of digital data is encoded and optically transmitted to the detector circuit. The detected signal is decoded and converted back into an analog

signal, which is filtered to obtain the final output signal.

In the sigma-delta modulator, the input signal is sampled at a very high rate (5-10 million samples per second) using a switched-capacitor circuit similar to that shown in Figure 4. Because the input sampling capacitors need to fully charge within only one half of a clock cycle, the peak input current of the isolation amplifier can be much larger than the average input current. These peak input currents are the primary reason for the recommended bypass capacitors at the inputs of the isolation amplifier.

The input bypass capacitors also form part of a simple anti-aliasing filter, which is recommended to prevent high-frequency noise from aliasing down to lower frequencies and interfering with the input signal.

Agilent isolation amplifiers incorporate additional features specifically designed to improve their performance in current-sensing applications, particularly in motor drives.

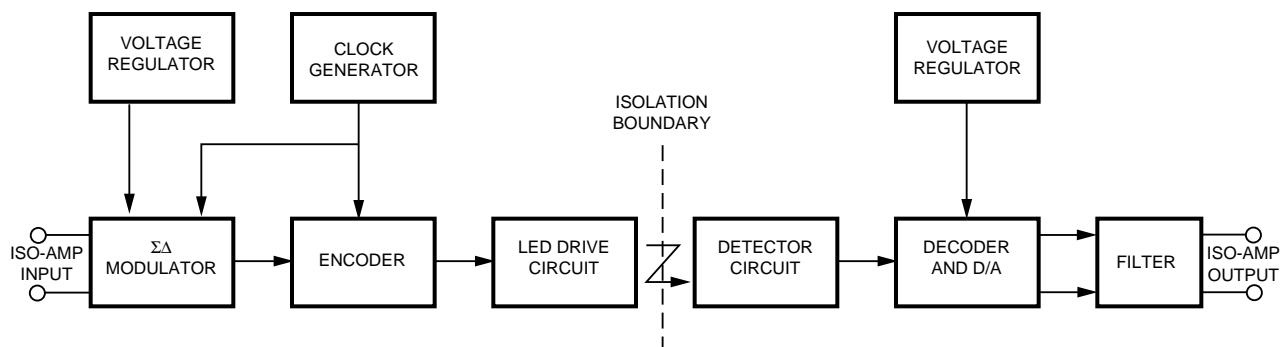

Figure 2. HCPL-7820 Block Diagram.

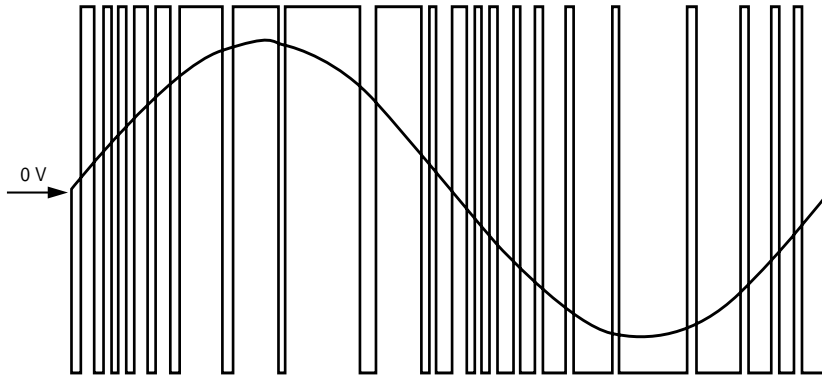

Figure 3. Example Sigma-Delta Modulation.

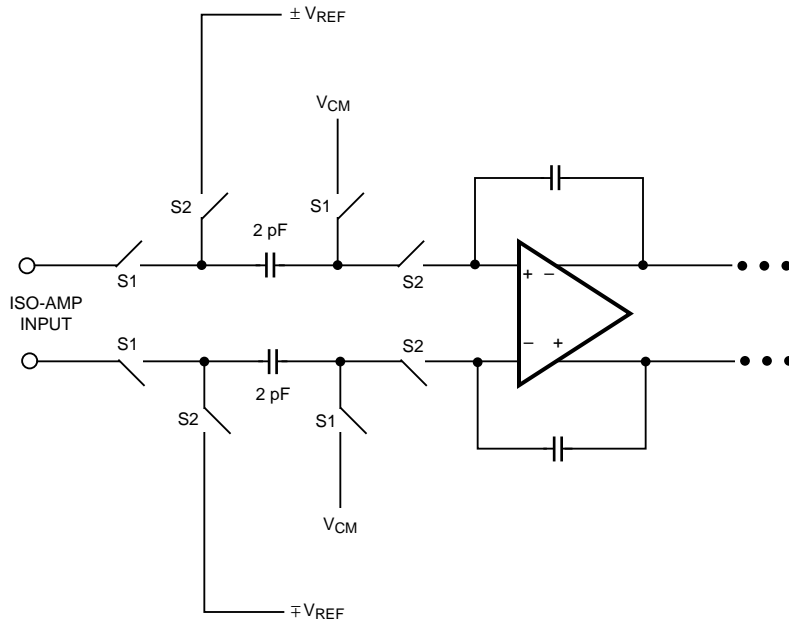

Figure 4. Input Sampling Network.

Chopper stabilization of all critical internal amplifiers and a fully differential circuit topology allow operation with small full-scale input voltages while maintaining excellent input offset and offset drift performance. Small input voltages help to minimize power dissipation in the external current sensing resistor. In addition, a unique input circuit allows accurate sensing of input signals below ground, eliminating the need for split supplies for the input circuit and allowing the use of a single +5 V supply.

Application Circuit

The recommended application circuit is shown in Figure 5. A floating power supply (which in many applications could be the same supply that is used to drive the high-side power transistor) is regulated to 5 V using a simple three-terminal voltage regulator (U1). The voltage from the current sensing resistor or shunt (R_{sense}) is applied to the input of the HCPL-7820 (U2) through an

RC anti-aliasing filter (R5 and C3). And finally, the differential output of the isolation amplifier is converted to a ground-referenced single-ended output voltage with a simple differential amplifier circuit (U3 and associated components). Although the application circuit is relatively simple, a few recommendations should be followed to ensure optimal performance.

Supplies and Bypassing

The power supply for the isolation amplifier is most often obtained from the same supply used to power the power transistor gate drive circuit. If a dedicated supply is required, in many cases it is possible to add an additional winding on an existing transformer. Otherwise, some sort of simple isolated supply can be used, such as a line powered transformer or a high-frequency DC-DC converter.

As mentioned above, an inexpensive 78L05 three-terminal regulator (U1) can be used to reduce the gate-drive power supply voltage to 5 V. To help attenuate high-frequency power supply noise or ripple, a resistor or inductor can be used in series with the input of the regulator to form a low-pass filter with the regulator's input bypass capacitor.

As shown in Figure 5, 0.1 μF bypass capacitors (C2 and C4) should be located as close as possible to the input and output power-supply pins of the isolation amplifier (U2). The bypass capacitors are required because of the high-speed digital nature of the signals inside the isolation

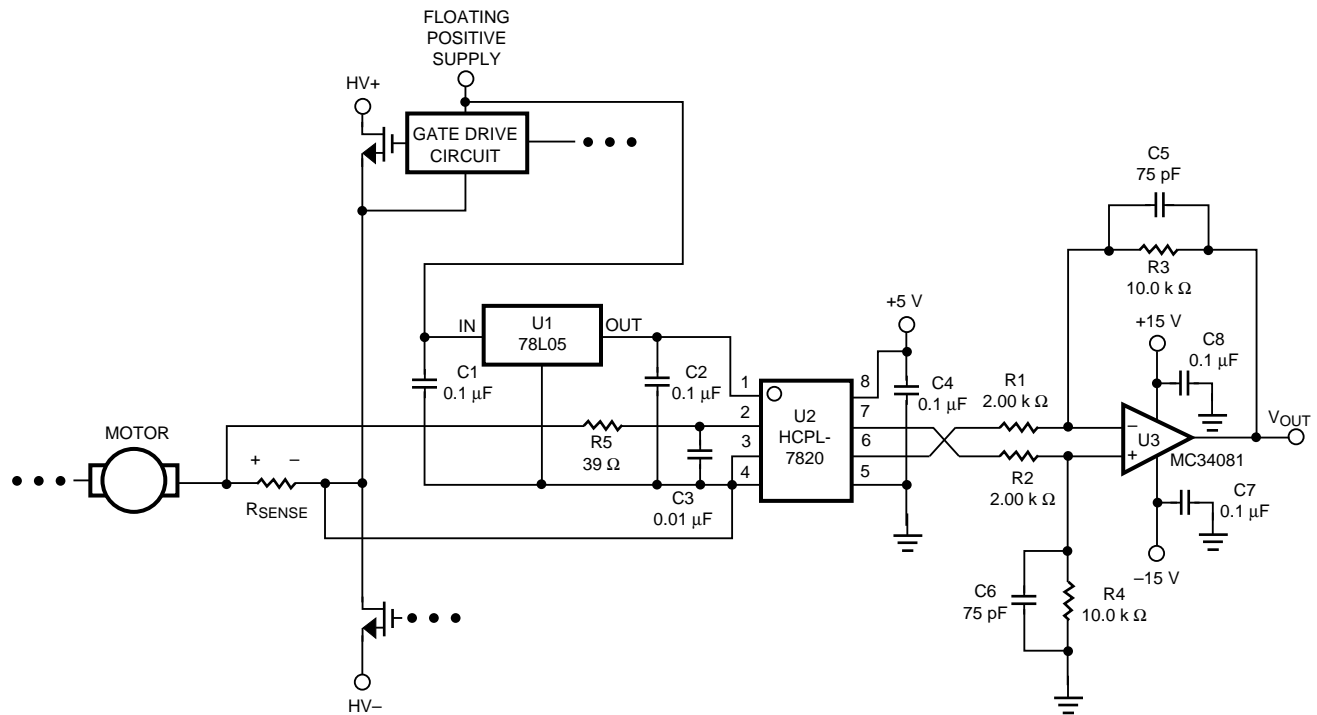

Figure 5. Recommended Application Circuit for the HCPL-7820.

amplifier. A $0.01\ \mu\text{F}$ bypass capacitor (C3) is also recommended at the input pin(s) due to the switched-capacitor nature of the input circuit.

The placement of the power-supply and input bypass capacitors can change the offset at the input of the isolation amplifier. This change in offset arises from inductive coupling between the input power-supply bypass capacitor and the input circuit, which includes the input bypass capacitor and the input leads of the isolation amplifier. A portion of the high-frequency power-supply bypass current is at the sampling frequency of the input signal; induced voltages at this frequency will alias down to DC, increasing the effective offset of the isolation amplifier. Because of this effect, metallic objects in close proximity to the input circuit can also affect the offset due to the permeability

of the metal changing the relevant inductances.

Several steps can be taken to minimize the mutual coupling between these two parts of the circuit, thereby improving the offset performance of the design. Separate the two bypass capacitors (C2 and C3) as much as possible (even placing them on opposite sides of the printed circuit board), while keeping the total lead lengths, including traces, of each bypass capacitor less than 20 mm. The printed circuit (PC) board traces should be made as short as possible and placed close together or over a ground plane to minimize loop area and pickup of stray magnetic fields. Avoid using sockets, as they will typically increase both loop area and inductance. Finally, using capacitors with small body size and orienting them (C2 and C3) perpendicular to each other on the PC board can also help. Figure 6

shows an example through-hole PC board layout for the isolation amplifier input circuit which illustrates some of the suggestions described above. The layout shown in Figure 6 is meant for illustrative purposes and cannot be reproduced photographically to generate a working PC board.

It is also possible to utilize this mutual coupling to advantage. For example, the layout shown in Figure 6 can be modified to enhance the inductive coupling in such a way as to minimize offset drift over temperature, as shown in Figure 7. The objective of this layout is to cancel the mutual coupling effects as much as possible. To accomplish this, the input leads cross over each other close to the package and then form a loop with the input bypass capacitor (C3). This input loop is inside of another loop formed by the power supply traces and

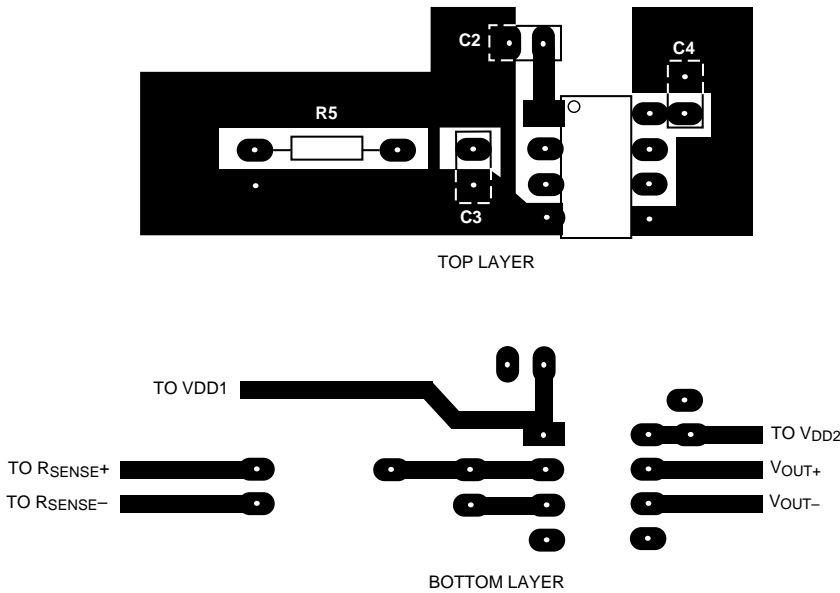

Figure 6. Example PC Board Layout for Isolation Amplifier Input Circuit.

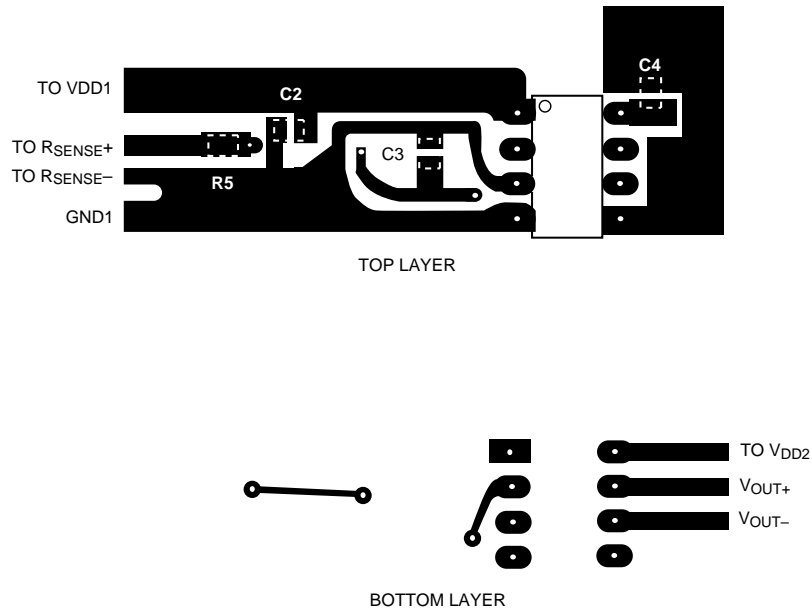

Figure 7. Example Surface-Mount PC Board Layout to Minimize Offset Tempco.

the power supply bypass capacitor (C2). The polarity of the coupling between these two loops is such that it tends to cancel the undesirable mutual coupling effects described above. By adjusting the area of the inner loop (e.g., by shifting the position of the input

bypass capacitor left or right on the layout), the amount of coupling can be varied to achieve the correct amount of cancellation. This method of offset tempco cancellation can shift the mean tempco of a group of devices closer to zero, but cannot perfectly

cancel the tempco for every device due to part-to-part variations. The offset tempco can typically be reduced by a factor of two or more. Unfortunately, this reduction in offset drift comes at the price of a slight increase in initial offset, on the order of 1-2 mV of additional offset for the HCPL-7820. Similar to Figure 6, the layout in Figure 7 is meant for illustrative purposes only.

Shunt Resistors

The current-sensing shunt resistor should have low resistance (to minimize power dissipation), low inductance (to minimize di/dt induced voltage spikes which could adversely affect operation), and reasonable tolerance (to maintain overall circuit accuracy). Choosing a particular value for the shunt is usually a compromise between minimizing power dissipation and maximizing accuracy. Smaller shunt resistances decrease power dissipation, while larger shunt resistances can improve circuit accuracy by utilizing the full input range of the isolation amplifier.

The first step in selecting a shunt is determining how much current the shunt will be sensing. The graph in Figure 8 shows the RMS current in each phase of a three-phase induction motor as a function of average motor output power (in horsepower, hp) and motor drive supply voltage. The maximum value of the shunt is determined by the current being measured and the maximum recommended input voltage of the isolation amplifier. The maximum shunt resistance can be calculated by taking the maximum recommended input voltage and dividing by the peak current that

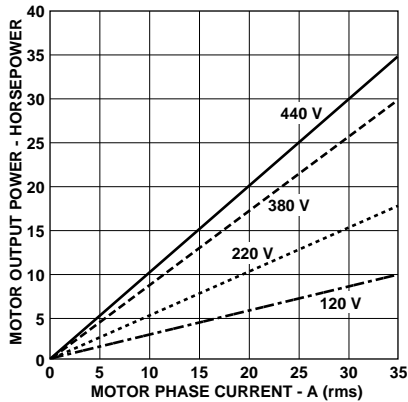

Figure 8. Motor Output Horsepower vs. Motor Phase Current and Supply Voltage.

the shunt should see during normal operation. For example, if a motor will have a maximum RMS current of 10 A and can experience up to 50% overloads during normal operation, then the peak current is 21.1 A ($= 10 \cdot 1.414 \cdot 1.5$). Assuming a maximum input voltage of 200 mV, the maximum value of shunt resistance in this case would be about 10 mΩ.

The maximum average power dissipation in the shunt can also be easily calculated by multiplying the shunt resistance times the square of the maximum RMS current, which is about 1 W in the previous example.

If the power dissipation in the shunt is too high, the resistance of

the shunt can be decreased below the maximum value to decrease power dissipation. The minimum value of the shunt is limited by precision and accuracy requirements of the design. As the shunt value is reduced, the output voltage across the shunt is also reduced, which means that the offset and noise of the isolation amplifier, which are fixed, become a larger percentage of the signal amplitude.

Usually, the actual value of the shunt will fall somewhere between the minimum and maximum values, depending on the particular requirements of a specific design.

Agilent recommends four different two-terminal shunts from Dale which can be used to sense average currents in motor drives up to 35 A and 35 hp. Table 1 shows the maximum current and horsepower range for each of the recommended LVR-series shunts. Even higher currents can be sensed with lower value four-terminal shunts available from vendors such as Dale, IRC, and Isotek (Isabellenhuetten); it is also possible to make your own four-terminal shunts by stamping out an appropriate pattern from a sheet of metal alloy that has a low temperature coefficient.

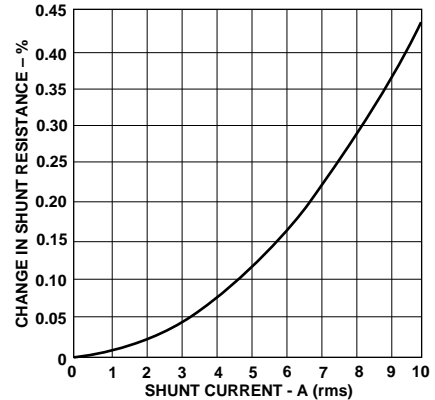

Figure 9. LVR Shunt Resistance Change vs. Shunt Current.

When sensing currents large enough to cause significant heating of the shunt, the temperature coefficient (tempco) of the shunt can introduce nonlinearity due to the signal dependent temperature rise of the shunt. For example, Figure 9 shows how the resistance of the LVR shunt resistors typically changes as a function of average current flowing through it with the shunt mounted in a typical PC board configuration. Although the effect shown in Figure 9 is relatively small, it increases as the shunt-to-ambient thermal resistance increases. This effect can be minimized either by reducing the thermal resistance of the shunt

Table 1. Current Shunt Summary.

Shunt Resistor Part Number	Shunt Resistance	Tolerance	Maximum Power Dissipation	Maximum RMS Current	Maximum Horsepower Range
LVR-3.05-1%	50 mΩ	1%	3 W	8 A	0.8 - 3.0 hp
LVR-3.02-1%	20 mΩ	1%	3 W	8 A	2.2 - 8.0 hp
LVR-3.01-1%	10 mΩ	1%	3 W	15 A	4.1 - 15 hp
LVR-5.005-1%	5 mΩ	1%	5 W	35 A	9.6 - 35 hp

or by using a shunt with a lower tempco. Lowering the thermal resistance can sometimes be as easy as repositioning the shunt on the PC board, or it might sometimes require the use of a heat sink.

As the value of shunt resistance decreases, the resistance of the shunt leads becomes a significant percentage of the total shunt resistance. This has two primary effects on shunt accuracy. First, the effective resistance of the shunt can become dependent on factors such as how long the leads are, how they are bent, how far they are inserted into the board, and how far solder wicks up the lead during assembly (these issues will be discussed in more detail shortly). Second, the leads are typically made from a material, such as copper, which has a much higher tempco than the material from which the resistive element itself is made, resulting in a higher tempco for the shunt overall.

Both of these effects are eliminated when a four-terminal shunt is used. A four-terminal shunt has two additional terminals that are Kelvin-connected directly across the resistive element itself; these two terminals are used to monitor the voltage across the resistive element while the other two terminals are used to carry the load current. Because of the Kelvin connection, any voltage drops across the leads carrying the load current will have little, if any, impact on the measured voltage.

Although four-terminal shunts can perform better than two-terminal shunts, they are more expensive, generally limiting their use to higher precision applications.

Two-terminal shunts, however, can deliver good performance when they are used properly. One of the most difficult aspects of using a two-terminal shunt is achieving an accurate, repeatable connection to the shunt, which is typically mounted on a PC board. Figure 10 shows an illustrative example of a PC board layout that can achieve good performance with two-terminal shunts with resistances down to about 5 mΩ.

There are several things to note about this layout. Two “quasi-Kelvin” connections are provided to make as close to a point contact as possible to the shunt leads where they contact the PC board. The quasi-Kelvin connections are brought together under the body of the shunt and then run very close to each other to the input of the isolation amplifier; this minimizes the loop area of the connec-

tion and reduces the possibility of stray magnetic fields (of which there are plenty in a motor drive) from interfering with the measured signal. If the shunt is not located on the same PC board as the isolation amplifier circuit, a tightly twisted pair of wires can accomplish the same thing.

Also note that both sides of the PC board are used to increase current carrying capacity. Numerous plated-through vias (shown as circles with a center cross in Figure 10) surround each terminal of the shunt to help distribute the current between the two sides of the PC board. The PC board should use 2 or 4 oz. copper for the two layers, resulting in a current carrying capacity of 10 to 20 A. Making the current carrying traces on the PC board fairly large can improve the shunt’s power dissipation capability by acting

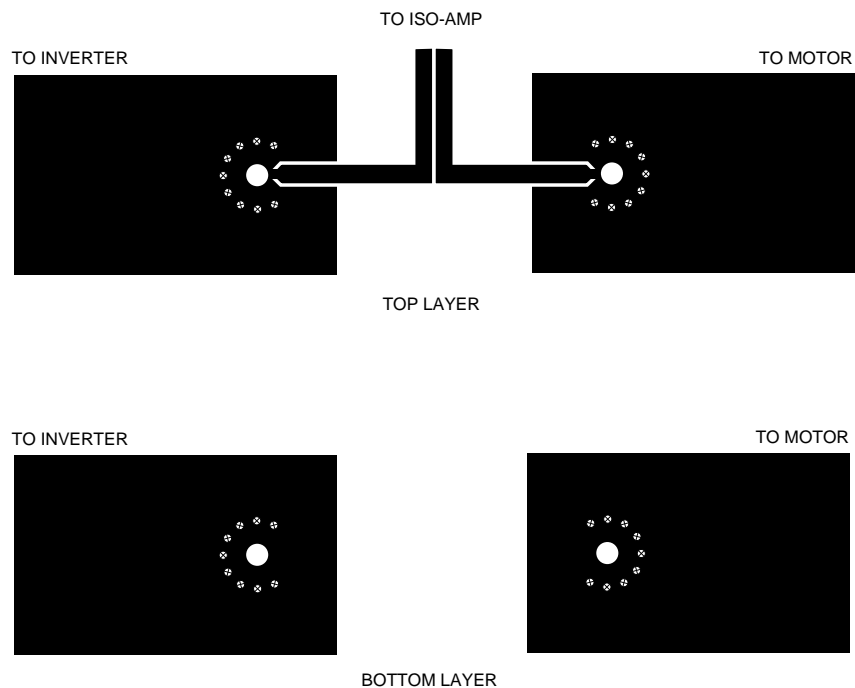

Figure 10. Example PC Board Layout for Two-Terminal Shunt.

as a heat sink. Liberal use of vias where the load current enters and exits the PC board is also recommended for the same reasons they are recommended for use at the shunt.

The final recommendation regarding the use of two-terminal shunts is to ensure that the leads of the shunt are consistently bent in the same way and inserted into the PC board the same distance every time. This is usually not a problem for automated assembly, but it could be for low-volume hand-assembled boards. For hand-assembled boards, a lead bending jig should be used and care should be taken that the shunt is inserted all the way into the board every time, minimizing any variability in the length of each shunt's leads.

An alternative to using shunts for measuring large AC currents is to

use an inexpensive current transformer connected to the input of the isolation amplifier, as shown in Figure 11. Using a transformer is less invasive than a current shunt and can significantly reduce power dissipation when measuring large currents (greater than 50 A). Because the isolation amplifier is providing the primary isolation barrier, a low-cost current transformer can be used that has little or no isolation of its own.

Shunt Connections

The recommended method for connecting the isolation amplifier to the shunt resistor is shown in Figure 5. V_{IN+} (pin 2 of the HPCL-7820) is connected to the positive terminal of the shunt resistor, while V_{IN-} (pin 3) is shorted to GND1 (pin 4), with the power-supply return path functioning as the sense line to the nega-

tive terminal of the current shunt. This allows a single pair of wires or PC board traces to connect the isolation amplifier circuit to the shunt resistor. By referencing the input circuit to the negative side of the sense resistor, any load current induced noise transients on the shunt are seen as a common-mode signal and will not interfere with the current-sense signal. This is important because the large load currents flowing through the motor drive, along with the parasitic inductances inherent in the wiring of the circuit, can generate both noise spikes and offsets that are relatively large compared to the small voltages that are being measured across the current shunt.

If the same power supply is used both for the gate drive circuit and for the current sensing circuit, it is very important that the connection from GND1 of the isolation amplifier to the sense resistor be the **only** return path for supply current to the gate drive power supply in order to eliminate potential ground loop problems. The only direct connection between the isolation amplifier circuit and the gate drive circuit should be the floating positive power supply line.

In some applications, however, supply currents flowing through the power-supply return path may cause offset or noise problems. In this case, better performance may be obtained by connecting V_{IN+} and V_{IN-} directly across the shunt resistor with two conductors, and connecting GND1 to the shunt resistor with a third conductor for the power-supply return path, as shown in Figure 12. When connected this way, both input

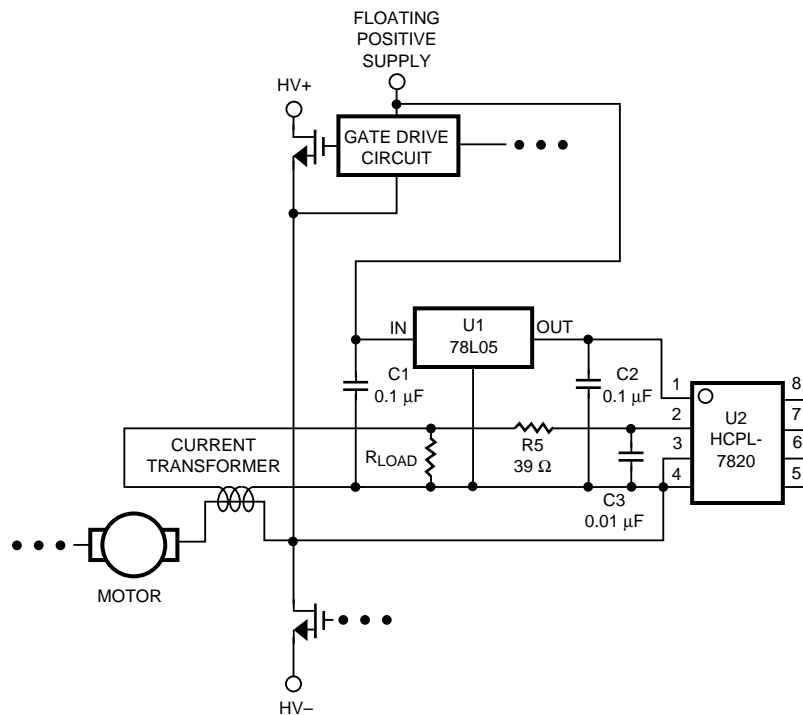

Figure 11. Using a Non-isolated Current Transformer to Measure Large AC Currents.

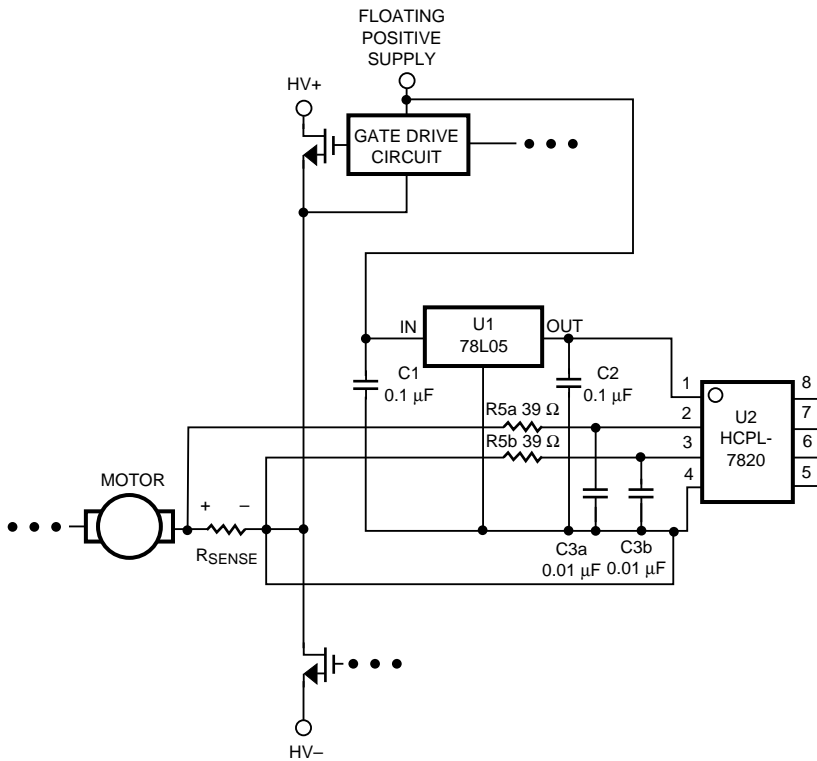

Figure 12. Schematic for Three-Conductor Shunt Connection.

pins should be bypassed. To minimize electro-magnetic interference of the sense signal, all of the conductors (whether two or three are used) connecting the isolation amplifier to the sense resistor should be either twisted pair wire or closely spaced traces on a PC board.

The 39 Ω resistor in series with the input lead (R5) forms a low-pass anti-aliasing filter with the 0.01 μF input bypass capacitor (C3) with a 400 kHz bandwidth. The resistor performs another important function as well; it dampens any ringing which might be present in the circuit formed by the shunt, the input bypass capacitor, and the inductance of wires or traces connecting the two. Undamped ringing of the input circuit near the

input sampling frequency can alias into the baseband producing what might appear to be noise at the output of the device.

PC Board Layout

In addition to affecting offset, the layout of the PC board can also affect the common mode rejection (CMR) performance of the isolation amplifier, due primarily to stray capacitive coupling between the input and the output circuits. To obtain optimal CMR performance, the layout of the PC board should minimize any stray coupling by maintaining the maximum possible distance between the input and output sides of the circuit and ensuring that any ground plane on the PC board does not pass directly below or extend much wider than the body

of the isolation amplifier. Using surface-mount components can help achieve many of the PC board objectives discussed in the preceding paragraphs. An example through-hole PC board layout illustrating some of the more important layout recommendations is shown in Figure 6. Note that the ground plane does not extend directly below the body of the isolation amplifier.

A surface-mount layout of the complete application circuit shown in Figure 5 is available from the Agilent Applications Engineering Department; the size of the layout, including shunt resistor, is approximately 3 cm square. Contact your local Agilent sales office for more information.

Post-Amplifier Circuit

The recommended application circuit shown in Figure 5 includes a post-amplifier circuit that serves three functions: to reference the output signal to the desired level (usually ground), to amplify the signal to appropriate levels, and to help filter output noise. The particular op-amp used in the post-amplifier circuit is not critical; however, it should have low enough offset and high enough bandwidth and slew rate so that it does not adversely affect circuit performance. The maximum offset of the op-amp should be low relative to the output offset of the HCPL-7820, or less than about 5 mV. The gain is determined by resistors R1 through R4; assuming that R1 = R2 and R3 = R4, the gain of the post-amplifier is R3/R1.

To maintain the fastest overall circuit bandwidth and speed, the post-amplifier circuit should

have a bandwidth at least twice the minimum bandwidth of the isolation amplifier, or about 400 kHz; lower bandwidths can be used to decrease output noise at the expense of slower response times. If capacitors C5 and C6 are not used in the post-amplifier circuit, the post-amplifier bandwidth is determined by the gain-bandwidth product (GBW) of the op-amp. To obtain a bandwidth of 400 kHz with a gain of 5, the op-amp should have a GBW greater than 2 MHz. Using the op-amp GBW to set the overall circuit bandwidth is generally not a very good idea because the op-amp GBW is usually specified only as a typical, with no guaranteed values.

More accurate control of the post-amplifier circuit bandwidth can be achieved by using capacitors C5 and C6 to form a single-pole low-pass filter with a nominal bandwidth of $1/(2 \cdot \pi \cdot R3 \cdot C5)$, assuming that $R3 = R4$ and $C5 = C6$. These capacitors allow the bandwidth of the post-amplifier to be adjusted independently of the gain and are useful for reducing the output noise of the isolation amplifier.

To accurately set the low-pass filter frequency using C5 and C6, the op-amp should have a specified GBW greater than approximately ten times the product of the post-amplifier gain and the desired low-pass frequency; a GBW lower than that would change the low-pass frequency by more than 10 - 15%. For a post-amplifier gain of 5 and a low-pass frequency of 200 kHz, the GBW of the op-amp should be at least 7 - 10 MHz. The component values shown in Figure 5 form a differential amplifier with a gain of 5 and a cutoff frequency of

approximately 200 kHz and were chosen as a compromise between low noise and fast response times. The overall recommended application circuit, including a typical isolation amplifier, has a bandwidth of about 130 kHz, a rise time of 2.6 μ s and delay to 90% of 4.2 μ s.

In addition to having enough bandwidth, the op-amp should have adequate slew rate to accurately reproduce large amplitude waveforms. The required slew rate can be conservatively estimated by dividing the maximum expected voltage swing at the output of the amplifier circuit by the filter time constant, which is equal to the product of R3 and C5. This estimate is more conservative at higher filter bandwidths because the overall response time of the circuit is then dominated by the response time of the isolation amplifier. For example, assuming a ± 200 mV input swing, a post-amplifier gain of 5 and a filter bandwidth of 200 kHz, the required slew rate of the op-amp is estimated to be approximately 20 V/ μ s, whereas less than 10V/ μ s is actually needed.

The gain-setting resistors in the post-amp should have a tolerance of 1% or better to ensure adequate CMRR and gain tolerance for the overall circuit. Significant mismatch of the gain-setting resistors can degrade the CMRR of the post-amplifier, contributing to offset of the circuit. Figure 13 shows how much additional offset (referred to the input of the isolation amplifier, assuming an isolation amplifier gain of 8) can be expected versus post-amplifier gain for different values of resistor tolerance. Shown in Figure 13 is the standard

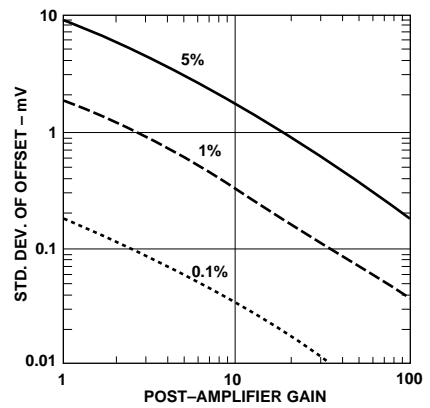

Figure 13. Standard Deviation of Post-amplifier Input-referred Offset vs. Post-amplifier Gain and Resistor Tolerance.

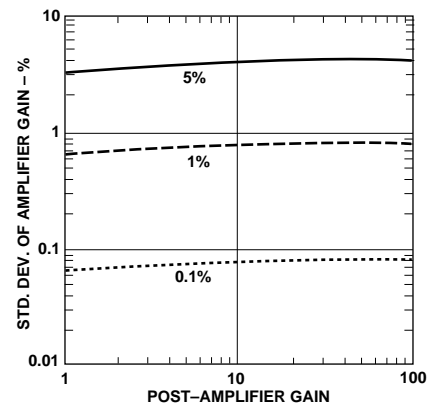

Figure 14. Standard Deviation of Post-amplifier Gain vs. Post-amplifier Gain and Resistor Tolerance.

deviation of the resulting distribution of input offsets; the mean of the distribution is zero, as would be expected from a differential amplifier circuit. In a similar way, Figure 14 shows how much additional gain tolerance the post-amplifier contributes to the overall circuit versus post-amplifier gain for different values of resistor tolerance. Figure 14 indicates the standard deviation of the resulting gain distribution of the post-amplifier circuit. The data in

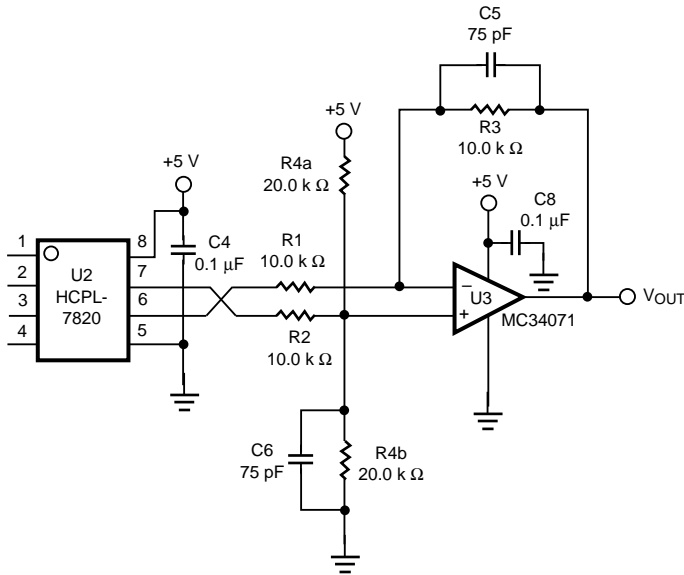

Figure 15. Single-supply Post-amplifier Circuit for HCPL-7820.

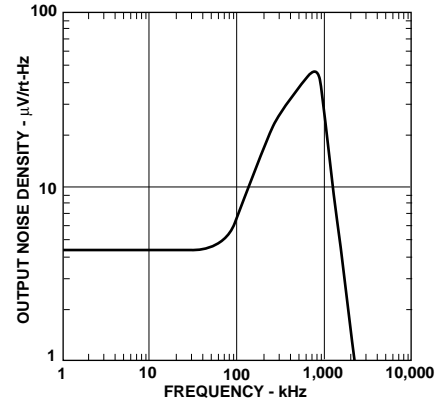

Figure 16. HCPL-7820 Output Noise Spectrum.

Figures 13 and 14 were generated by Monte Carlo simulation and conservatively assume that resistor values are uniformly distributed around their nominal value. Resistor networks with very tight ratio tolerances, from suppliers such as Dale, can be used which offer excellent performance as well as reduced component count and board space.

The post-amplifier circuit can be easily modified to allow for single-supply operation. Figure 15 shows a schematic for a post-amplifier for use in 5 V single-supply applications. One additional resistor (R4a) is needed and the gain is decreased to allow circuit operation over the full input voltage range. Adding the resistor shifts the output reference voltage from zero to one-half of the supply voltage.

Output Noise

The noise-shaping characteristic of the sigma-delta modulator results in a slightly unusual output noise spectrum, as shown in Figure 16 for the HCPL-7820. The noise spectrum is flat up to about 40 kHz, where it breaks up at 12 dB per octave. The internal filter begins to roll off the noise spectrum at about 200 kHz, with a steep drop just below 1 MHz. The shape of the noise spectrum has some implications regarding the most effective method of filtering output noise for a given signal bandwidth.

As mentioned before, reducing the bandwidth of the post-amplifier circuit reduces the amount of output noise (as well as increasing the response time). Due to the increasing noise behavior above 40 kHz, a second-order filter response can be much more effective at filtering noise than a first-order filter, depending on the

particular filter bandwidth. Figure 17 shows how the output noise changes as a function of the post-amplifier bandwidth for both first- and second-order filter responses. The application circuit shown in Figure 5 exhibits a first-order low-pass filter characteristic. By adding two additional resistors and a capacitor (R1a, R2a and C9), as shown in Figure 18, a second-order filter response can be obtained. Capacitor C9 should be chosen so that the product of R1a and C9 is equal to the product of R3 and C5.

Changing the bandwidth of the post-amplifier will also affect the delay of the circuit. Figure 17 also indicates how the delay (to 90%) of the application circuit changes as a function of the post-amplifier bandwidth for both first- and second-order filter responses. From this graph it is easy to determine the trade-offs between output noise, circuit delay and amplifier bandwidth.

The output noise of the modulator is also affected by the amplitude of the input signal. Figure 19 shows the relative amplitude of the RMS output voltage versus the DC input voltage. The curve is relatively flat out to about ± 200 mV and increases rapidly for input signals larger than that. The increase in noise with amplitude is independent of the output filter bandwidth.

The statistical characteristics (probability density function) of the output noise are important when the isolation amplifier is used to sense an overload or fault condition and you need to determine how close the signal can get to the threshold before you start to get false overload indications. The output noise of the isolation amplifier is nearly gaussian when the input voltage is near zero. As the input voltage moves away from zero, the noise becomes less gaussian, with the tails of the probability distribution lengthening in the direction of mid-scale and shortening in the direction of full-scale, as shown in Figure 20. For the HCPL-7820, Figure 21 shows how much above a particular DC input the fault detection threshold (input referred) should be for different levels of false alarm probability. For example, to limit the probability of a false alarm to 0.01% for a 200 mV input, the fault detection threshold should be at least 214 mV (a 14 mV threshold margin). The maximum recommended fault detection threshold is about 275 mV.

To reduce offset in some applications, the offset is measured by a microprocessor at power-up and then subtracted from every subsequent measurement. For these types of auto-calibration applications, accuracy can be

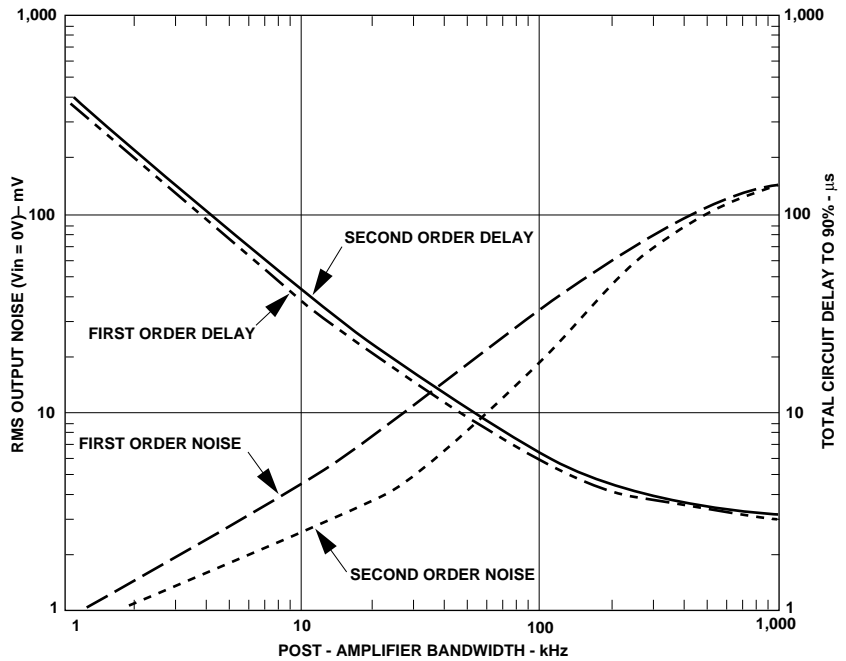

Figure 17. RMS Output Noise and Delay of the HCPL-7820 Application Circuit vs. Post-amplifier Bandwidth and Filter Order.

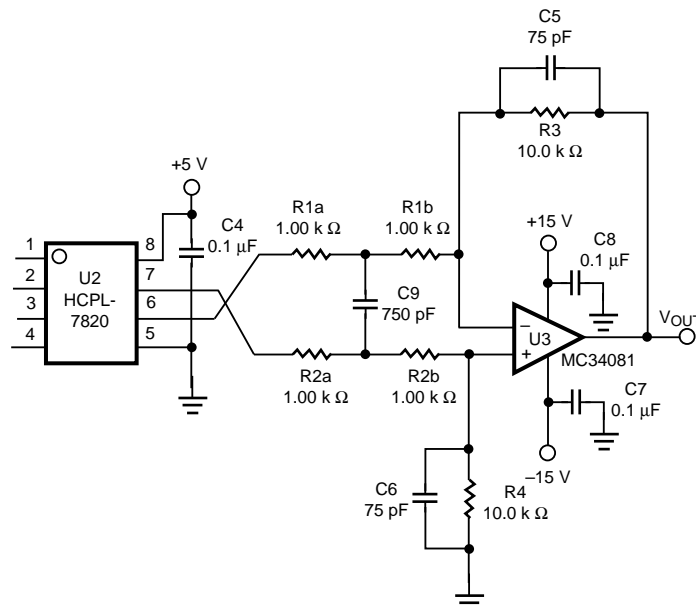

Figure 18. Post-amplifier Circuit with Second-order Filter Response.

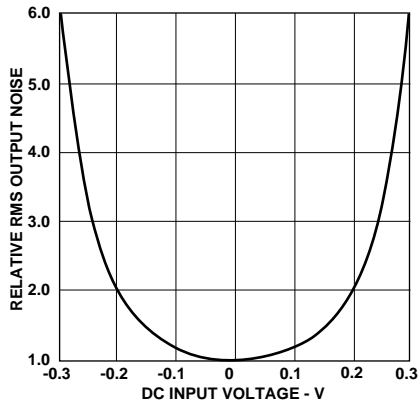

Figure 19. Relative Output Noise vs. DC Input Voltage.

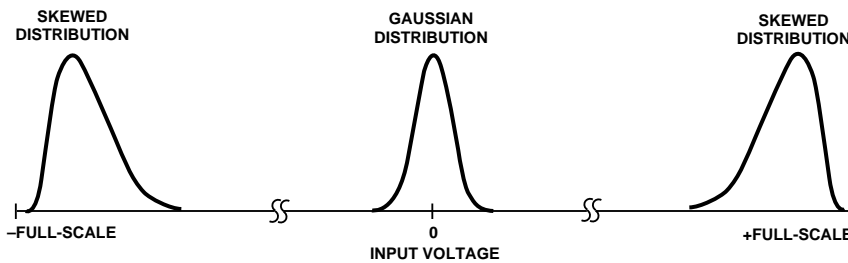

Figure 20. Noise Statistical Characteristics vs. Input Voltage.

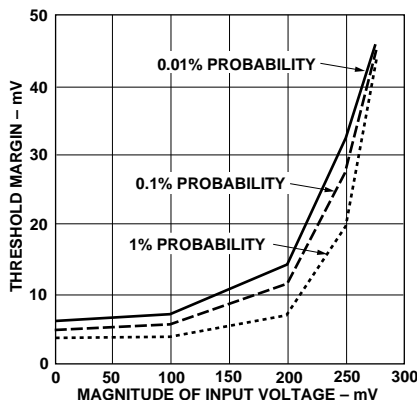

Figure 21. HCPL-7820 Threshold Detection Margin vs. Input Voltage and False Alarm Probability.

improved by waiting until the internal junction temperature stabilizes before measuring the offset of the isolation amplifier. For example, the HCPL-7820 has an offset drift at power-up of about 100 μV with a time constant of approximately 15 seconds when mounted on a relatively small evaluation board. Accuracy can also be improved by additional filtering or averaging of the measured signal to reduce any noise during the auto-calibration procedure.

Voltage Sensing

Agilent isolation amplifiers can also be used to isolate signals with amplitudes larger than its recommended input range with the use of a resistive voltage divider at its input. The only restrictions are that the impedance of the divider be relatively small (less than 1 k Ω) so that the input resistance (280 k Ω) and input bias current (1 μA) of the isolation amplifier do not affect the accuracy of the measurement. An input bypass capacitor is still required, although the 39 Ω series damping resistor is not (the resistance of the voltage divider provides the same function). The low-pass filter formed by the divider resistance and the input bypass capacitor may limit the achievable bandwidth. To obtain higher bandwidths, the input bypass capacitor (C3) can be reduced, but it should not be reduced much below 1000 pF to maintain gain accuracy of the isolation amplifier.

SPICE Models

SPICE models for Agilent isolation amplifiers are available from the Agilent Applications Engineering Department. Contact your local Agilent sales office for more information.



www.semiconductor.agilent.com

Data subject to change.

Copyright © 1999 Agilent Technologies, Inc.

Obsoletes 5963-5484E

5965-5976E (11/99)

SUNSTAR 商斯达实业集团是集研发、生产、工程、销售、代理经销、技术咨询、信息服务等为一体的高科技企业，是专业高科技电子产品生产厂家，是具有 10 多年历史的专业电子元器件供应商，是中国最早和最大的仓储式连锁规模经营大型综合电子零部件代理分销商之一，是一家专业代理和分销世界各大品牌 IC 芯片和电子元器件的连锁经营综合性国际公司，专业经营进口、国产名厂名牌电子元件，型号、种类齐全。在香港、北京、深圳、上海、西安、成都等全国主要电子市场设有直属分公司和产品展示展销窗口门市部专卖店及代理分销商，已在全国范围内建成强大统一的供货和代理分销网络。我们专业代理经销、开发生产电子元器件、集成电路、传感器、微波光电元器件、工控机/DOC/DOM 电子盘、专用电路、单片机开发、MCU/DSP/ARM/FPGA 软件硬件、二极管、三极管、模块等，是您可靠的一站式现货配套供应商、方案提供商、部件功能模块开发配套商。商斯达实业公司拥有庞大的资料库，有数位毕业于著名高校——有中国电子工业摇篮之称的西安电子科技大学（西军电）并长期从事国防尖端科技研究的高级工程师为您精挑细选、量身订做各种高科技电子元器件，并解决各种技术问题。

微波光电部专业代理经销高频、微波、光纤、光电元器件、组件、部件、模块、整机；电磁兼容元器件、材料、设备；微波 CAD、EDA 软件、开发测试仿真工具；微波、光纤仪器仪表。欢迎国外高科技微波、光纤厂商将优秀产品介绍到中国、共同开拓市场。长期大量现货专业批发高频、微波、卫星、光纤、电视、CATV 器件：晶振、VCO、连接器、PIN 开关、变容二极管、开关二极管、低噪晶体管、功率电阻及电容、放大器、功率管、MMIC、混频器、耦合器、功分器、振荡器、合成器、衰减器、滤波器、隔离器、环行器、移相器、调制解调器；光电子器件和组件：红外发射管、红外接收管、光电开关、光敏管、发光二极管和发光二极管组件、半导体激光二极管和激光器组件、光电探测器和光接收组件、光发射接收模块、光纤激光器和光放大器、光调制器、光开关、DWDM 用光发射和接收器件、用户接入系统光收发器件与模块、光纤连接器、光纤跳线/尾纤、光衰减器、光纤适配器、光隔离器、光耦合器、光环行器、光复用器/转换器；无线收发芯片和模组、蓝牙芯片和模组。

更多产品请看本公司产品专用销售网站：

商斯达微波光电产品网：[HTTP://www.rfoe.net/](http://www.rfoe.net/)

商斯达中国传感器科技信息网：<http://www.sensor-ic.com/>

商斯达工控安防网：<http://www.pc-ps.net/>

商斯达电子元器件网：<http://www.sunstare.com/>

商斯达消费电子产品网：<http://www.icasic.com/>

商斯达实业科技产品网：<http://www.sunstars.cn/> 射频微波光电元器件销售热线：

地址：深圳市福田区福华路福庆街鸿图大厦 1602 室

电话：0755-83396822 83397033 83398585 82884100

传真：0755-83376182 (0) 13823648918 MSN: SUNS8888@hotmail.com

邮编：518033 E-mail:szss20@163.com QQ: 195847376

深圳赛格展销部：深圳华强北路赛格电子市场 2583 号 电话：0755-83665529 25059422

技术支持：0755-83394033 13501568376

欢迎索取免费详细资料、设计指南和光盘；产品凡多，未能尽录，欢迎来电查询。

北京分公司：北京海淀区知春路 132 号中发电子大厦 3097 号

TEL: 010-81159046 82615020 13501189838 FAX: 010-62543996

上海分公司：上海市北京东路 668 号上海赛格电子市场 D125 号

TEL: 021-28311762 56703037 13701955389 FAX: 021-56703037

西安分公司：西安高新开发区 20 所(中国电子科技集团导航技术研究所)

西安劳动南路 88 号电子商城二楼 D23 号

TEL: 029-81022619 13072977981 FAX:029-88789382