

# Overview of Agilent's Optical Isolation Technology and Products for Motor Control Applications

## The solution to your need for optical isolation.

### Solution Note 101

The need for optical isolation technology is ever increasing in power electronics circuits. Agilent Technologies offers a vast choice of high performance digital and analog optocouplers as well as application-specific devices that contain isolation amplifier and power transistor driver functions especially suited for isolating signals in various motor control and power electronics circuits. In addition to optocouplers, Agilent offers fiber-optic transmitters and receivers, and motion sensing components for industrial applications. The four basic applications in motor control systems that can use optical isolation technology are the power switch, voltage and current sensor, and data communication circuits. In some situations, there is also a requirement for position control, and Agilent's optoelectronic motion-sensing devices address this need. This paper focuses on the various optocoupler applications in motor control and power conversion circuits, and briefly discusses each of these applications along with a recommended list of Agilent optocouplers and isolation

amplifiers. For details on Agilent's fiber-optic links and motion sensing devices, refer to your Agilent Optoelectronic Designer's Catalog.

#### Isolation of the Power Switch

With Agilent's optocoupler technology of high speed and low current AlGaAs light emitting diodes (LEDs), high insulation packaging, and high transient rejection integrated circuits (IC), today's power electronics designer has great flexibility in designing high-performance circuits that isolate the high-voltage power transistor circuits from low-voltage, logic-level control circuits. Figure 1 shows how optical isolation can be used in a three-phase, pulse-width modulated (PWM) power inverter. In this example, optocouplers provide isolation in the power transistor drive circuit, the motor current-sensing circuit, and the high-voltage dc power supply sensing circuit. Furthermore, both Agilent optocouplers and fiberoptic links can be used in external communication lines coming into the controller, and Agilent motion sensing devices can be used for velocity and position information. As power

conversion technology continues to improve with more versatile, efficient, and high-speed switching devices, more performance is needed from optocouplers. Agilent provides a full range of optocouplers that meet the stringent demands of these new motor control designs. For example, with Agilent's unique electric shield IC technology, the HCPL-4503 optocoupler has the industry's best common-mode rejection (CMR) specifications - a guaranteed specification of 15,000 V/ $\mu$ s with 1,500 V peak voltage. The HCPL-2600 and 2200 family of optocouplers provide larger gain-bandwidth product than the HCPL-4503 for higher gain and faster speed. And the HCPL-3000 series of optocouplers provide built-in power integrated circuits, ideally suited to directly drive the bases of bipolar power-transistors and Darlington's, or the gates of insulated-gate bipolar transistors (IGBTs), and power metal-oxide semiconductor field-effect transistors (MOSFETs). In addition, these optocouplers provide a wide range of LED drive currents, and supply and output voltages.



**Agilent Technologies**

The electrical switching of the power inverter creates significant common-mode voltage interference within the circuit. Figure 2a shows how Agilent's highest CMR optocoupler, HCPL-4503, can be used to drive an IGBT.

Notice that a gate/base drive circuit is required between the HCPL-4503 and the gate of the IGBT. For higher speed operation, the HCPL-4504 can be used instead of the HCPL-4503 optocoupler. The HCPL-4504 also has a higher current transfer ratio and a guaranteed propagation delay difference ( $t_{PLH} - t_{PHL}$ ) specification that helps designers minimize the *dead time* in their power inverter designs. (*Dead time* is defined as the period in which both the high and low side power transistors are off during switching transitions.) The propagation delay difference specification is useful for determining not only how much optocoupler switching delay is needed to prevent *shoot through* current but also for determining the best achievable worst-case dead time for a given design. (*Shoot through* current occurs when both the low and high side power transistors are on at the same time during switching transitions.)

Figure 2b shows an alternative technique for driving an IGBT with the use of the HCPL-3101 integrated driver optocoupler. In this example, the sourcing and sinking current rating of the HCPL-3101 is sufficient to directly drive an IGBT without the use of an additional discrete pushpull stage. With an output supply voltage of up to 35 volts, and peak drive current of 0.4 A, the HCPL-3101 can switch both power MOSFETs and IGBTs that have gate capacitances up to 3000 pF. For switching bipolar

power transistors and Darlington's up to 30 A or more, the HCPL-3000 can drive 2 A peak- and 1 A steady-state base current. The HCPL-3000 family of optocouplers not only provides 5000-V rms momentary withstand insulation protection between the power and control circuits, but also prevent up to 600-V peak, and 5000 V/ $\mu$ s transients from interfering with normal circuit operation. These integrated pushpull drivers eliminate extra circuitry, resulting in smaller board space and lower costs to the user. Designing with Agilent 3000 series and HCPL-4503/4, manufacturers of power electronic equipment can now build highly integrated, reliable, low-energy consumption, acoustic-noise-free control systems for industrial, home and office use.

#### Isolation of the Current and Voltage Sensor

One of the challenges a designer faces is trying to isolate the precision analog signal from the motor current-sensing element. Even in an extremely high electrical noise environment, the HCPL-7800 high CMR isolation amplifier provides the precision and stability needed to accurately monitor motor current for tighter control in various applications. The HCPL-7800 offers a cost-effective replacement of traditional motor sensing devices such as Hall-Effect devices. This extremely small (7.5 mm x 9.7 mm) 8-pin dual in-line packaged Agilent device makes it the world's smallest isolation amplifier. As shown in Figure 3, the HCPL-7800 requires a simple interface circuit which includes a current sensing resistor. Compared to Hall-

Effect sensors, the HCPL-7800 has excellent gain and offset characteristics, including very low drift over temperature. In addition, the HCPL-7800 features a very high common-mode rejection specification of 15,000 V/ $\mu$ s at 1000 V peak voltage; it is not affected by external magnetic fields; and it does not exhibit residual magnetization effects that can effect offset. This device's versatile features allows the same circuit and layout for sensing different motor current ranges simply by substituting different current-shunts. This unique set of features makes the HCPL-7800 an excellent choice for sensing current up to 200 A or more, covering a wide range of motor control applications.

The HCPL-7800 can also be used for sensing the rectified dc power supply voltage in a power inverter. Since the HCPL-7800 has a specification of 300 mV maximum input voltage before clipping, the dc power supply voltage should be converted to a proportionally smaller voltage. Figure 4a shows a simple resistor divider stage (R1 and R2) before the input of the HCPL-7800. The output of the HCPL-7800 is proportional to the high-voltage dc power supply.

A second technique for voltage sensing using the HCPL-4562 analog optocoupler is shown in Figure 4b. This servo-type analog isolation technique requires no isolated power supply on the high-voltage side of the isolation barrier. Referring to Figure 4b, the forward current through the LED of U1 HCPL-4562 is proportional to the voltage of the dc high voltage power supply. When the circuit is balanced, the LED forward

current through U1 and U3 HCPL-4562s are approximately the same. This in turn produces an output voltage VO which is proportional to the high voltage dc power supply. Another technique for measuring the high voltage dc supply voltage and current, or for isolating the motor speed signal, uses Agilent's CNR201 high-linearity analog optocoupler, and is shown in Figure 4c. This circuit generates two output signals: an analog signal proportional to the magnitude of the input signal, and a digital signal corresponding to the sign of the input signal. This circuit is useful for applications where the output of the circuit is applied to an analog-to-digital converter. The CNR201 features a feedback photodiode that monitors the light output of the LED. As a result, the nonlinearity, drift, and aging effects of the LED can be virtually eliminated. The close matching of the two photodiodes in the CNR201 produces very good linearity (0.01% typical), and stable gain (65 ppm/°C).

#### Isolation of the Communication Line

Often the motor control microprocessor logic circuitry needs to communicate to the external world and in such data communication circuits, Agilent optocouplers and fiber-optic components can provide the necessary electrical isolation. Agilent optocouplers can easily be designed into industry standard data communication specifications such as RS 232 and RS 422. For special applications, Agilent's highspeed HCPL-7101 optocoupler with CMOS-compatible integrated circuit and highly efficient LED can transmit data up to 50 MBd. In addition, Agilent offers low-

cost plastic and glass fiber-optic links for industrial data communications. Special fiber-optic link components can also be obtained for the European industrial fiber-optic standard SERCOS (Serial Realtime COmmunication System).

Miniature surface-mount optocoupler packages are offered for high-density applications. In addition, dual-channel optocouplers are also available for some of the products.

#### Other Agilent Optoelectronic Components for Motor Control

**Agilent Fiber-Optic Devices:** Agilent offers two families of fiber-optic parts for industrial applications. The first family of very low cost 665-nm technology based devices is optimized for 1 mm plastic optical fiber cable. Utilizing plastic 1 mm plastic optical fiber cable, these fiber-optic links can transmit data over 100 m at 40 Kbd data rates, and up to 50 MBd for shorter distances. With 0.2 mm and 0.4 mm Hard Clad Silica (HCS) cable these transmitters and receivers can work up to 1000 m. The second Agilent fiber-optic link family for industrial applications is based on 820-nm LED technology and is most suitable for glass optical fiber. With 50 and 100  $\mu$ m core glass cable these fiber optic links can transmit very high speed data (>5 MBd) for several kilometer distances. The 825-nm based links have the added benefit of operating at industrial temperature between -40°C to +85°C.

**Agilent Motion Sensing Devices:** For position and velocity information, Agilent offers a family of motion sensing and control devices that are an extension of the

company's emitter and detector systems capabilities. Motion sensing products include optical shaft encoders and optical encoder modules for closed-loop servo applications, and rotary pulse generators for manual input applications. For more details on these devices, refer to the Motion Sensing and Control section of Agilent's Optoelectronics Designer's Catalog.

#### References

1. Application Note 1058, "Power Transistor Gate/Base Drive Optocouplers."
2. Application Note 1059, "High CMR Isolation Amplifier for Current Sensing Applications."

1Isabellenhütte in Germany (Tel. 49- 2771-23031), Isotek in the US (Tel. 508- 673-2900), and PCN in Japan (Tel 045-473-6441) offer a wide range of current shunts allowing the HCPL-7800 based circuit to sense current up to several hundred amperes. Some of the other current shunt suppliers are IRC in the USA (Tel. 704-264-8861), SIR in Italy (Tel. 39-3-31504828), KHS in Japan (Tel. 045-473-9933) and Dale worldwide (USA Tel. 402-563-6506)..

**Table 1. Optocouplers for Isolated Power Element Using a Discrete Push-Pull Driver**

Product	Package Style	Minimum CMR		Max T <sub>PROP</sub> ( $\mu$ s)	V <sub>CC</sub> (V)	Comments
		KV/ $\mu$ s	V <sub>CM</sub>			
HCPL-2211/12 HCPL-0211	Ia III	10	1000 V	0.3	4.5 - 20	Wide V <sub>CC</sub> , V <sub>O</sub> range; High Gain (low I <sub>F</sub> , I <sub>CC</sub> ); Good general purpose optocoupler.
HCPL-2611 HCPL-7611 HCPL-0611 CNW2611	Ia Ib III II	10 VCC = 5 V	1000 V	0.1	5 $\pm$ 10%	Very high CMR; Moderate gain; only, V <sub>O</sub> $\leq$ 20 V; High frequency switching rate; HCPL-7611 and CNW2601 meet IEC/EN/DIN EN 60747-5-2, UL, and other regulatory standards.
HCPL-4503 HCPL-4504 HCPL-0453/4 HCPL-M453/4 CNW4503	Ia Ia III IV II	15 10/15 10/15 10/15 15	1500 V 1500 V 1500 V 1500 V 1500 V	1 0.5/0.7 1 1 1	1.5 - 30 (V <sub>O</sub> $\leq$ 20 V)	Extremely high CMR; Wide V <sub>CC</sub> , V <sub>O</sub> range; Low gain (higher I <sub>F</sub> ); Slower response times; CNW 4503 meets IEC/EN/DIN EN 60747-5-2, UL and other regulatory standards.

**Table 2. Integrated Gate/Base Drive Optocouplers for Isolated Power Element**

Product	Package Style	Minimum CMR		Peak I <sub>O</sub> (A)	V <sub>CC</sub> (V)	Comments
		KV/us	V <sub>CM</sub>			
HCPL-3000	Ia	1.5	600 V	2	5.4 - 18	Wide V <sub>CC</sub> ; High output current; Best suited to driving power bipolar transistors and Darlingtonts.
HCPL-3100 HCPL-3101	Ia	1.5	600 V	0.4	15 - 30	Wide V <sub>CC</sub> ; 0.5 ms propagation delay (HCPL-3101); Best suited to driving IGBTs and power MOSFETs

**Table 3. Isolation Amplifier/Optocouplers for Current and Voltage Sensing**

Product	Package Style	Minimum CMR		$t_{PROP}$	Non-linearity	Comments
		KV/us	$V_{CM}$			
HCPL-7800 HCPL-7800A HCPL-7800B	lb	10	1000 V	5.6 us	0.1%	Compact isolation amplifier; 4.6 mV/°C offset drift; 0.9 mV input offset; Meets IEC/EN/DIN EN 60747-5-2, UL, and CSA regulatory standards.
CNR 200/201	II	95 dB Typ. IMRR*; f = 60 Hz		1.5 MHz	0.01%	Low cost, high linearity, Bandwidth analog optocoupler with LED light output feedback signal; Meets IEC/EN/DIN EN 60747-5-2, UL, CSA and other regulatory standards.
HCPL-4562	la	122 dB Typ. IMRR*; f = 120 Hz		tr/tf = 20 ns	0.25%	Linear performance, High CMR.
CNW4562	II	119 dB Typ. IMRR*; f = 120 Hz		tr/tf = 20 ns	0.25	Linear performance, High CMR; meets IEC/EN/DIN EN 60747-5-2, UL and other regulatory standards.

\*IMRR or Isolation Mode Rejection Ratio is a measure of the optocouplers capability to reject signals or noise between the input and output terminals. Refer to the technical data for test condition information.

**Table 4. Optocouplers for Line Receivers**

Product	Package Style	Minimum CMR		$I_F$ (mA)	$T_{PROP}$ (us)	Comments
		KV/us	$V_{CM}$			
HCPL-2601 HCPL-0601	la III	1	50 V	5	0.1	High CMR, 5 V logic, single channel.
HCPL-7601	lb	1	50 V	2	0.1	Low input current; Meets IEC/EN/DIN EN 60747-5-2, UL, and CSA regulatory standards.
HCPL-2631	la	1	50 V	5	0.1	Dual Channel.
CNW2601	III	1	50 V	5	0.1	Meets IEC/EN/DIN EN 60747-5-2, UL, and other regulatory standards
HCPL-4661	la	5	1000 V	5	0.1	Very high CMR, dual channel.

For technical data on Agilent Fiber-Optic Links and Motion Sensing products, refer to Agilent's Optoelectronic Designer's Catalog.

**Table 5. Optocoupler Package Style Information**

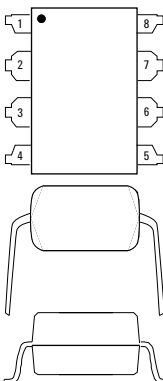
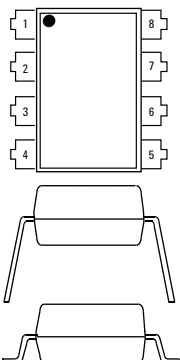
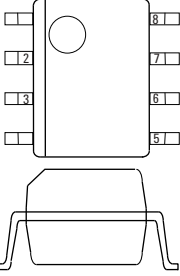
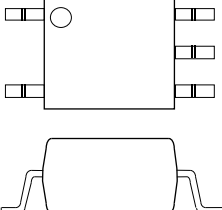
Package Style	Description	Creepage	Clearance	Regulatory Information
<p>Ia/Ib</p> 	<p>(Ia) 8-pin DIP</p> <p>(Ib) High Insulation 8-pin DIP</p>	8.0 mm	0.1 mm	UL 1577, 3750/5000 Vac/1 min.; CSA 0-M1982
<p>II</p> 	High Insulation Wide Body	10.0 mm	1.0 mm	UL 5000 Vac/1 min.; IEC/EN/DIN EN 60747-5-2 (VIORM = 1000 VRMS);
<p>■</p> 	Small Outline SOIC-8	6.9 mm	0.1 mm	UL 1577, 3750 Vac/1 min.
<p>IV</p> 	5-pin Low Profile Mini- Flat	6.9 mm	0.1 mm	UL 1577, 3750 Vac/1 min.pending

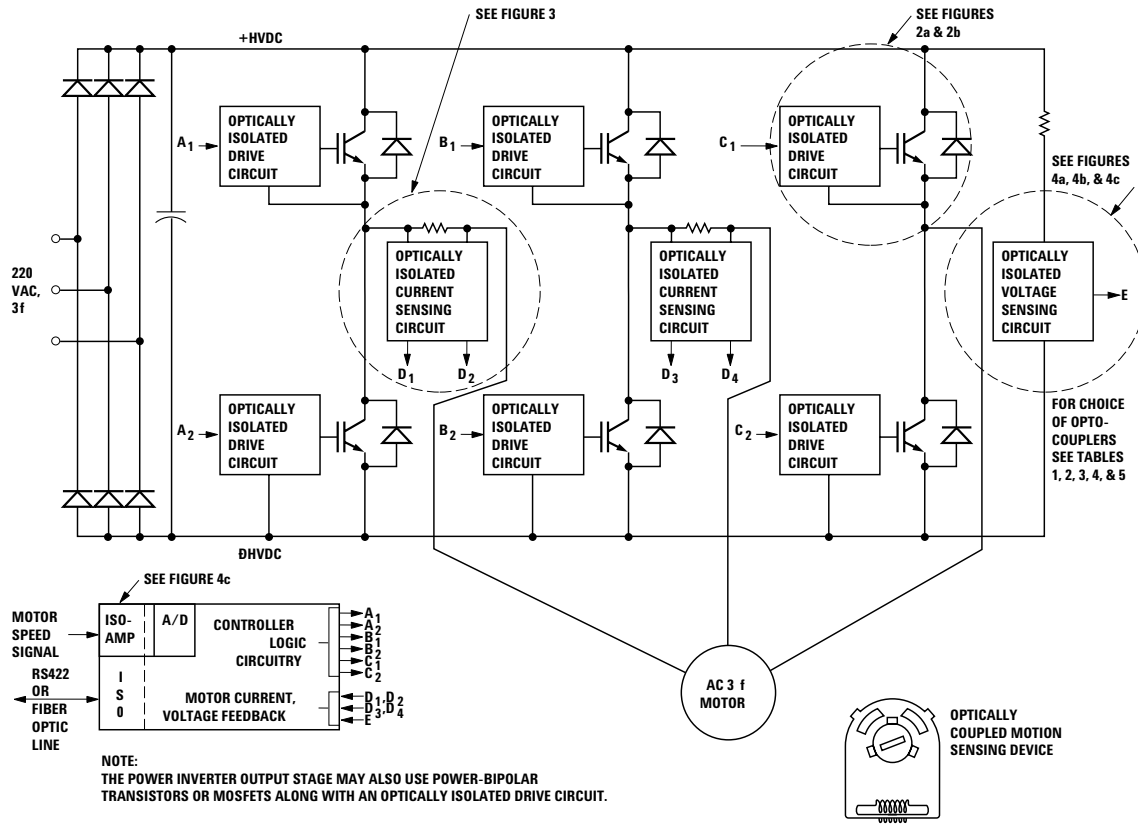

Figure 1. Power Inverter.

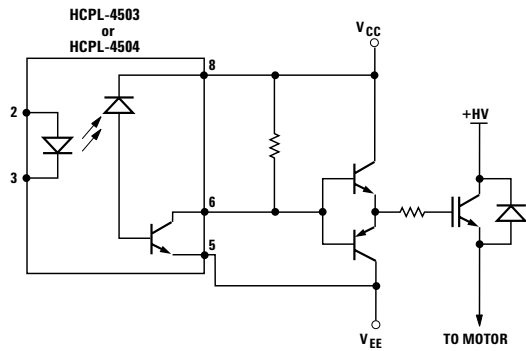

Figure 2a. Isolated Drive Circuit with an HCPL-4503/4 Optocoupler and a Discrete Push-Pull Driver.

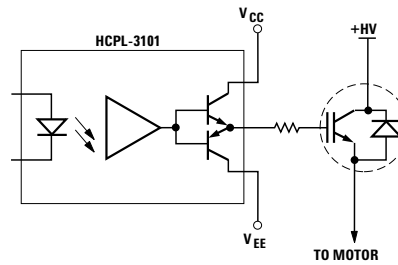

Figure 2b. Isolated Drive Circuit with an HCPL-3100/1 Integrated Gate Drive Optocoupler.

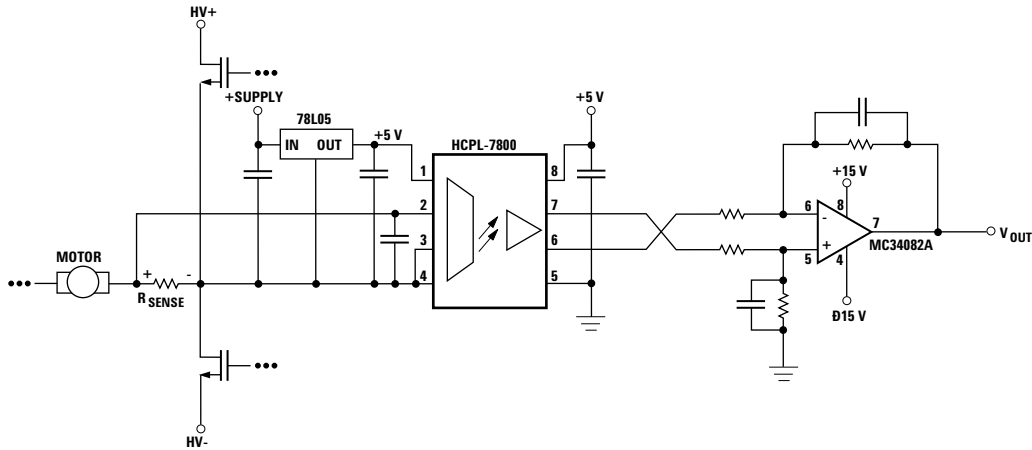

Figure 3. Optically Isolated Current Sensing Circuit with HCPL-7800 Isolation Amplifier.

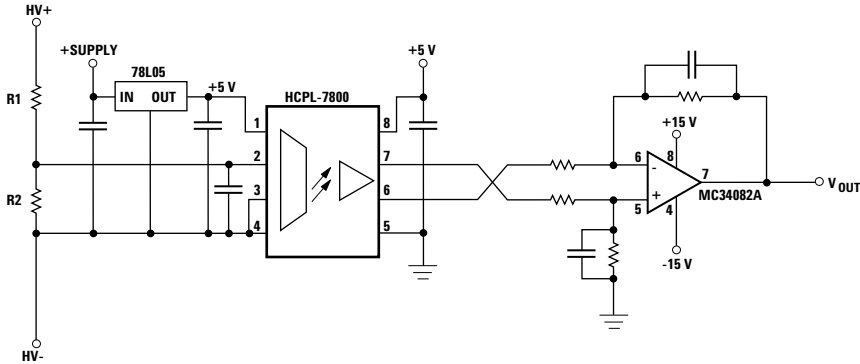

Figure 4a. Optically Isolated Voltage Sensing Circuit with HCPL-7800 Isolation Amplifier.

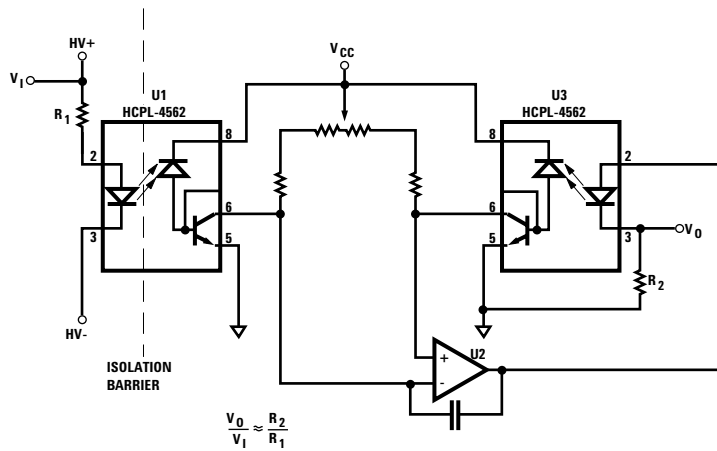
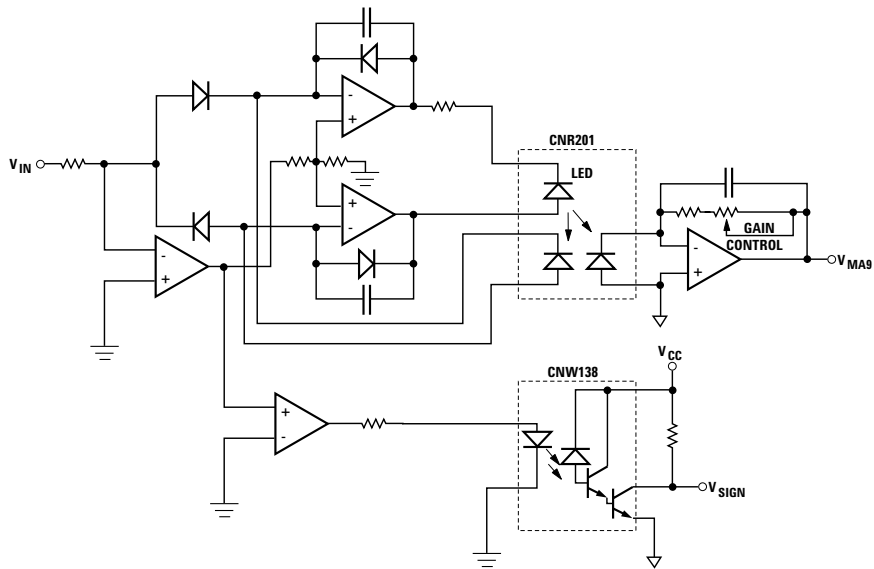

Figure 4b. Optically Isolated Voltage Sensing Circuit with HCPL-4562 Linear Optocoupler.





**Figure 4c. Magnitude/Sign Isolation Amplifier for High Voltage DC Supply Voltage/Current Sensing, and Motor Speed Control Isolation.**

**www.agilent.com/  
semiconductors**

For product information and a complete list of distributors, please go to our web site.

For technical assistance call:

Americas/Canada: +1 (800) 235-0312  
or (408) 654-8675

Europe: +49 (0) 6441 92460

China: 10800 650 0017

Hong Kong: (+65) 6756 2394

India, Australia, New Zealand: (+65) 6755 1939

Japan: (+81 3) 3335-8152(Domestic/International), or 0120-61-1280(Domestic Only)

Korea: (+65) 6755 1989

Singapore, Malaysia, Vietnam, Thailand, Philippines, Indonesia: (+65) 6755 2044

Taiwan: (+65) 6755 1843

Data subject to change.

Copyright © 2004 Agilent Technologies, Inc.

May 5, 2004

5989-1057EN



**Agilent Technologies**

SUNSTAR 商斯达实业集团是集研发、生产、工程、销售、代理经销、技术咨询、信息服务等为一体的高科技企业，是专业高科技电子产品生产厂家，是具有 10 多年历史的专业电子元器件供应商，是中国最早和最大的仓储式连锁规模经营大型综合电子零部件代理分销商之一，是一家专业代理和分销世界各大品牌 IC 芯片和电子元器件的连锁经营综合性国际公司，专业经营进口、国产名厂名牌电子元件，型号、种类齐全。在香港、北京、深圳、上海、西安、成都等全国主要电子市场设有直属分公司和产品展示展销窗口门市部专卖店及代理分销商，已在全国范围内建成强大统一的供货和代理分销网络。我们专业代理经销、开发生产电子元器件、集成电路、传感器、微波光电元器件、工控机/DOC/DOM 电子盘、专用电路、单片机开发、MCU/DSP/ARM/FPGA 软件硬件、二极管、三极管、模块等，是您可靠的一站式现货配套供应商、方案提供商、部件功能模块开发配套商。商斯达实业公司拥有庞大的资料库，有数位毕业于著名高校——有中国电子工业摇篮之称的西安电子科技大学（西军电）并长期从事国防尖端科技研究的高级工程师为您精挑细选、量身订做各种高科技电子元器件，并解决各种技术问题。

微波光电部专业代理经销高频、微波、光纤、光电元器件、组件、部件、模块、整机；电磁兼容元器件、材料、设备；微波 CAD、EDA 软件、开发测试仿真工具；微波、光纤仪器仪表。欢迎国外高科技微波、光纤厂商将优秀产品介绍到中国、共同开拓市场。长期大量现货专业批发高频、微波、卫星、光纤、电视、CATV 器件：晶振、VCO、连接器、PIN 开关、变容二极管、开关二极管、低噪晶体管、功率电阻及电容、放大器、功率管、MMIC、混频器、耦合器、功分器、振荡器、合成器、衰减器、滤波器、隔离器、环行器、移相器、调制解调器；光电子器件和组件：红外发射管、红外接收管、光电开关、光敏管、发光二极管和发光二极管组件、半导体激光二极管和激光器组件、光电探测器和光接收组件、光发射接收模块、光纤激光器和光放大器、光调制器、光开关、DWDM 用光发射和接收器件、用户接入系统光收发器件与模块、光纤连接器、光纤跳线/尾纤、光衰减器、光纤适配器、光隔离器、光耦合器、光环行器、光复用器/转换器；无线收发芯片和模组、蓝牙芯片和模组。

更多产品请看本公司产品专用销售网站：

商斯达微波光电产品网：[HTTP://www.rfoe.net/](http://www.rfoe.net/)

商斯达中国传感器科技信息网：<http://www.sensor-ic.com/>

商斯达工控安防网：<http://www.pc-ps.net/>

商斯达电子元器件网：<http://www.sunstare.com/>

商斯达消费电子产品网：<http://www.icasic.com/>

商斯达实业科技产品网：<http://www.sunstars.cn/> 射频微波光电元器件销售热线：

地址：深圳市福田区福华路福庆街鸿图大厦 1602 室

电话：0755-83396822 83397033 83398585 82884100

传真：0755-83376182 (0) 13823648918 MSN: SUNS8888@hotmail.com

邮编：518033 E-mail:szss20@163.com QQ: 195847376

深圳赛格展销部：深圳华强北路赛格电子市场 2583 号 电话：0755-83665529 25059422

技术支持：0755-83394033 13501568376

欢迎索取免费详细资料、设计指南和光盘；产品凡多，未能尽录，欢迎来电查询。

北京分公司：北京海淀区知春路 132 号中发电子大厦 3097 号

TEL: 010-81159046 82615020 13501189838 FAX: 010-62543996

上海分公司：上海市北京东路 668 号上海赛格电子市场 D125 号

TEL: 021-28311762 56703037 13701955389 FAX: 021-56703037

西安分公司：西安高新开发区 20 所(中国电子科技集团导航技术研究所)

西安劳动南路 88 号电子商城二楼 D23 号

TEL: 029-81022619 13072977981 FAX:029-88789382