

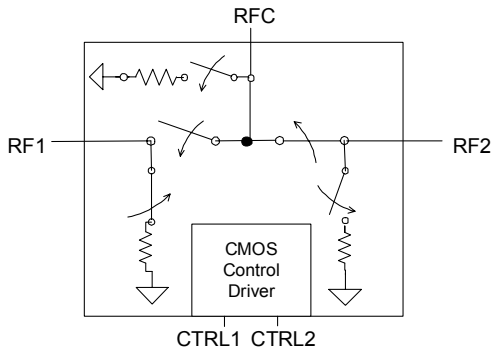


### Product Description

The PE4257 is a high-isolation UltraCMOS™ Switch designed for wireless applications, covering a broad frequency range from near DC up to 3000 MHz. This single-supply SPDT switch integrates a two-pin CMOS control interface. It also provides low insertion loss with extremely low bias requirements while operating on a single 3-volt supply. In a typical wireless application, the PE4257 provides unprecedented isolation and integration.

The PE4257 is manufactured on Peregrine's UltraCMOS™ process, a patented variation of silicon-on-insulator (SOI) technology on a sapphire substrate, offering the performance of GaAs with the economy and integration of conventional CMOS.

Figure 1. Functional Diagram



**50 Ω SPDT Absorptive UltraCMOS™  
DC – 3.0 GHz RF Switch**

### Features

- 50 Ω characteristic impedance
- Integrated 50 Ω 0.25 watt terminations
- High input IP3 > +55 dBm
- High isolation 64 dB at 1000 MHz
- Low insertion loss: typically 0.75 dB at 1000 MHz and 0.95 dB at 2000 MHz
- LV CMOS two-pin control
- Single +3 volt supply operation
- Low current consumption: 8 μA

Figure 2. Package Type

20-Lead 4x4 mm QFN



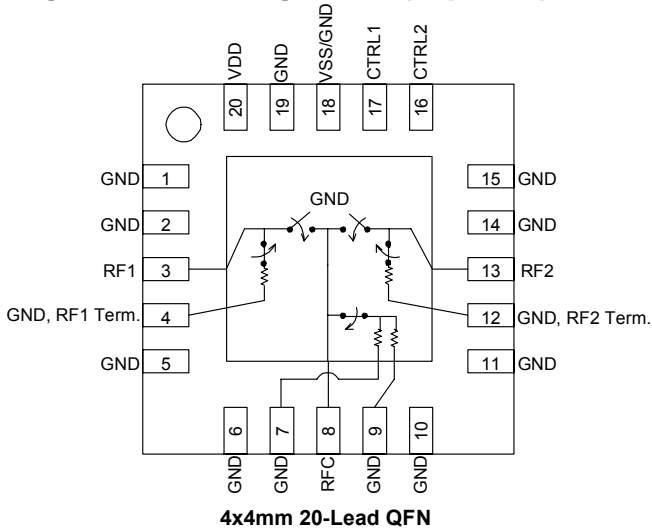
Table 1. Electrical Specifications @ +25 °C, V<sub>DD</sub> = 3.0 V (Z<sub>S</sub> = Z<sub>L</sub> = 50 Ω)

Parameter	Condition	Minimum	Typical	Maximum	Units
Operating Frequency <sup>1</sup>		DC		3000	MHz
Insertion Loss	1000 MHz		0.75	0.95	dB
	2000 MHz		0.95	1.15	
	3000 MHz		1.2	1.4	
Isolation Input to Output	1000 MHz	61	64		dB
	2000 MHz	46	50		
	3000 MHz	40	44		
Isolation Output to Output	1000 MHz	57	63		dB
	2000 MHz	54	60		
	3000 MHz	42	48		
Input IP2	5 MHz - 1000 MHz		80		dBm
Input IP3	5 MHz - 1000 MHz	50	55		dBm
Input 1dB Compression <sup>2</sup>	1000 MHz	29	31		dBm
Switching Time	50% CTRL to 10 / 90 RF		2		μs
Video Feedthrough <sup>3</sup>	5 MHz - 1000 MHz			15	mV <sub>pp</sub>

Notes: 1. Device linearity will begin to degrade below 1 MHz.

2. Note Absolute Maximum ratings in Table 3.

3. Measured with a 1 ns risetime, 0/3 V pulse and 500 MHz bandwidth

**Figure 3. Pin Configuration (Top View)**

**Table 2. Pin Descriptions**

No.	Name	Description
1	GND	RF Ground
2	GND	RF Ground
3 <sup>1</sup>	RF1	RF I/O
4	GND	RF Ground
5	GND	RF Ground
6	GND	RF Ground
7	GND	RF Ground
8 <sup>1</sup>	RFC	RF Common
9	GND	RF Ground
10	GND	RF Ground
11	GND	RF Ground
12	GND	RF Ground
13 <sup>1</sup>	RF2	RF I/O
14	GND	RF Ground
15	GND	RF Ground
16 <sup>2</sup>	CTRL2	Control 2
17 <sup>2</sup>	CTRL1	Control 1
18 <sup>3</sup>	VSS / GND	Negative Supply Option
19	GND	Digital Ground
20	VDD	Supply
Pad	GND	RF Ground Pad

**Notes:**

- RF pins 3, 8, and 13 must be at 0 VDC. The RF pins do not require DC blocking capacitors for proper operation if the 0 VDC requirement is met.
- Pins 16 and 17 are the CMOS controls that set the four operating states.
- Connect pin 18 to GND to enable the negative voltage generator. Connect pin 18 to V<sub>SS</sub> (-3 V) to bypass and disable internal -3 V supply generator. See paragraph "Switching Frequency."

**Table 3. Absolute Maximum Ratings**

Symbol	Parameter/Condition	Min	Max	Unit
V <sub>DD</sub>	Power supply voltage	-0.3	4.0	V
V <sub>I</sub>	Voltage on CTRL input	-0.3	V <sub>DD</sub> + 0.3	V
P <sub>RF</sub>	RF power on RFC, RF1, RF2 On Port/ Terminated Port		33/24	dBm
T <sub>ST</sub>	Storage temperature	-65	+150	°C
T <sub>OP</sub>	Operating temperature	-40	+85	°C
V <sub>ESD</sub>	ESD voltage (Human Body Model)	1000		V

Absolute Maximum Ratings are those values listed in the above table. Exceeding these values may cause permanent device damage. Functional operation should be restricted to the limits in the DC Electrical Specifications table. Exposure to absolute maximum ratings for extended periods may affect device reliability.

**Table 4. DC Electrical Specifications @ 25 °C**

Parameter	Min	Typ	Max	Unit
V <sub>DD</sub> Power Supply	2.7	3.0	3.3	V
I <sub>DD</sub> Power Supply Current (V <sub>DD</sub> = 3V, V <sub>CTRL</sub> = 3V)		8	20	μA
Control Voltage High	0.70 V <sub>DD</sub>			V
Control Voltage Low	0		0.30 V <sub>DD</sub>	V

**Latch-Up Avoidance**

Unlike conventional CMOS devices, UltraCMOS™ devices are immune to latch-up.

**Electrostatic Discharge (ESD) Precautions**

When handling this UltraCMOS™ device, observe the same precautions that you would use with other ESD-sensitive devices. Although this device contains circuitry to protect it from damage due to ESD, precautions should be taken to avoid exceeding the rating specified.

**Switching Frequency**

The PE4257 has a maximum 25 kHz switching rate when the internal negative voltage generator is used (pin 18=GND). The rate at which the PE4257 can be switched is only limited to the switching time if an external -3 V supply is provided at (pin18=V<sub>SS</sub>).

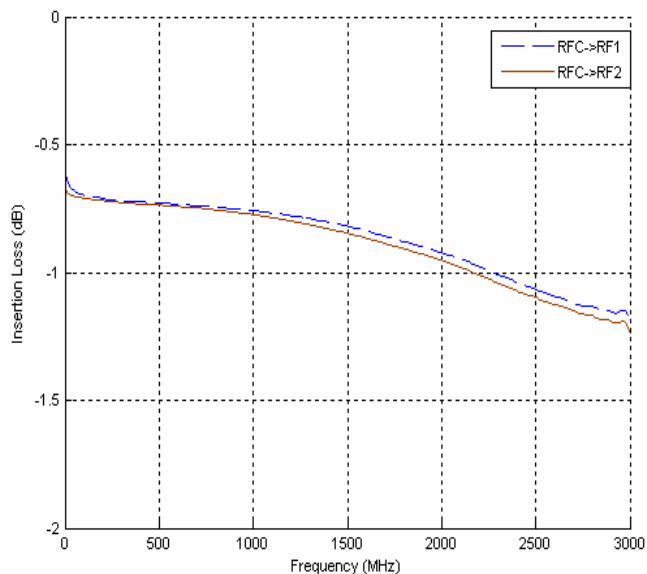
**Table 5. Truth Table**

<b>CTRL1</b>	<b>CTRL2</b>	<b>RFC – RF1</b>	<b>RFC – RF2</b>
Low	Low	OFF	OFF
Low	High	OFF	ON
High	Low	ON	OFF
High	High	N/A <sup>1</sup>	N/A <sup>1</sup>

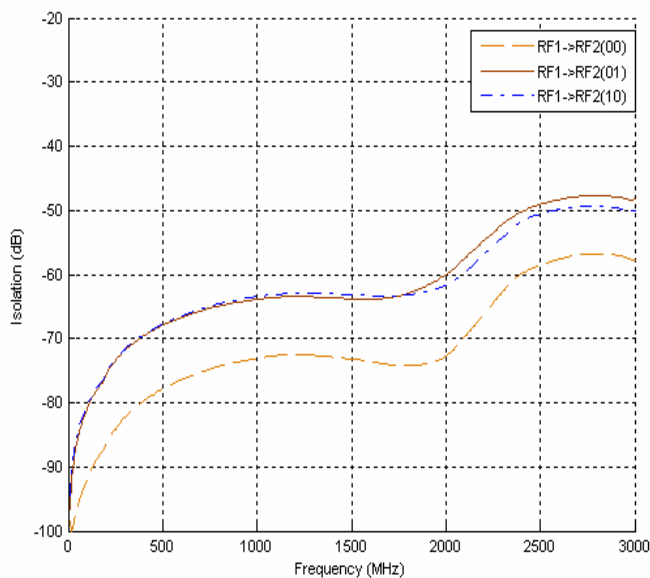
Notes: 1. The operation of the PE4257 is not supported or characterized in the C1=V<sub>DD</sub> and C2=V<sub>DD</sub> state.

**Typical Performance Data @ 25°C (Unless Otherwise Noted)**  
**(50-ohm impedance)**

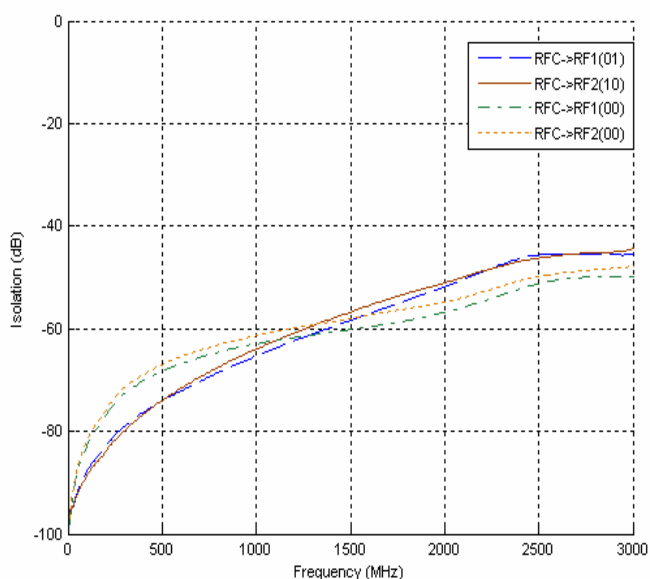
**Figure 4. Insertion Loss – Input - Output**



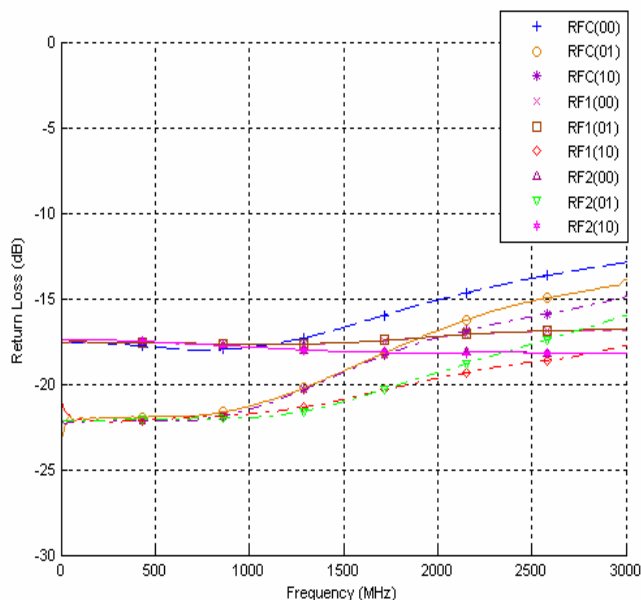
**Figure 5. RF1 to RF2 Isolation**



**Figure 6. Isolation – RFC to RF1/RF2**



**Figure 7. Return Loss**



### Evaluation Kit

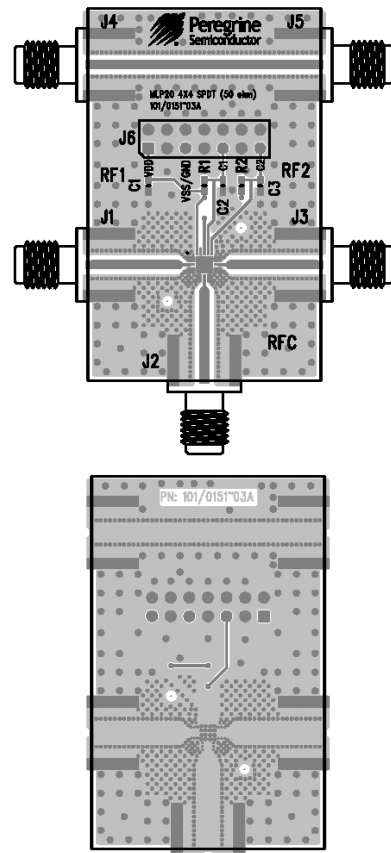
The SPDT Switch Evaluation Kit board was designed to ease customer evaluation of the PE4257 SPDT switch. The RF common port is connected through a 50 Ω transmission line to J2. Port 1 and Port 2 are connected through 50 Ω transmission lines to J1 and J3. A through transmission line connects SMA connectors J4 and J5. This transmission line can be used to estimate the loss of the PCB over the environmental conditions being evaluated.

The board is constructed of a four metal layer FR4 material with a total thickness of 0.031". The transmission lines were designed using a coplanar waveguide with ground plane (28 mil core, 47.6 mil width, 30mil gap).

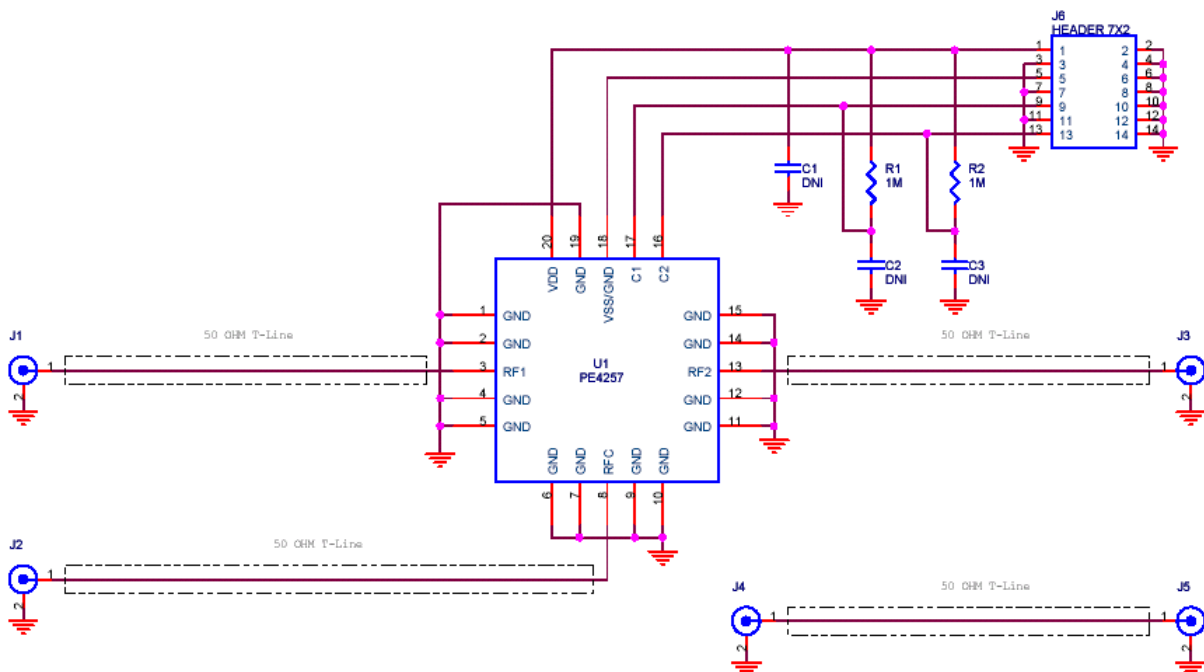
Note the number of vias surrounding the device in the layout shown in Figure 8. These vias are critical for obtaining the specified isolation performance for the device shown in this datasheet.

J6 provides a means for controlling DC and digital inputs to the device. The provided jumpers short the package pin to ground for logic low. When the jumper is removed, the pin is pulled up to VDD for logic high. When the jumper is in place, 3 μA of current will flow through the 1 MΩ pull up resistor. This extra current should not be attributed to the requirements of the device.

**Figure 8. Evaluation Board Layouts**  
Peregrine Specification 101/0151

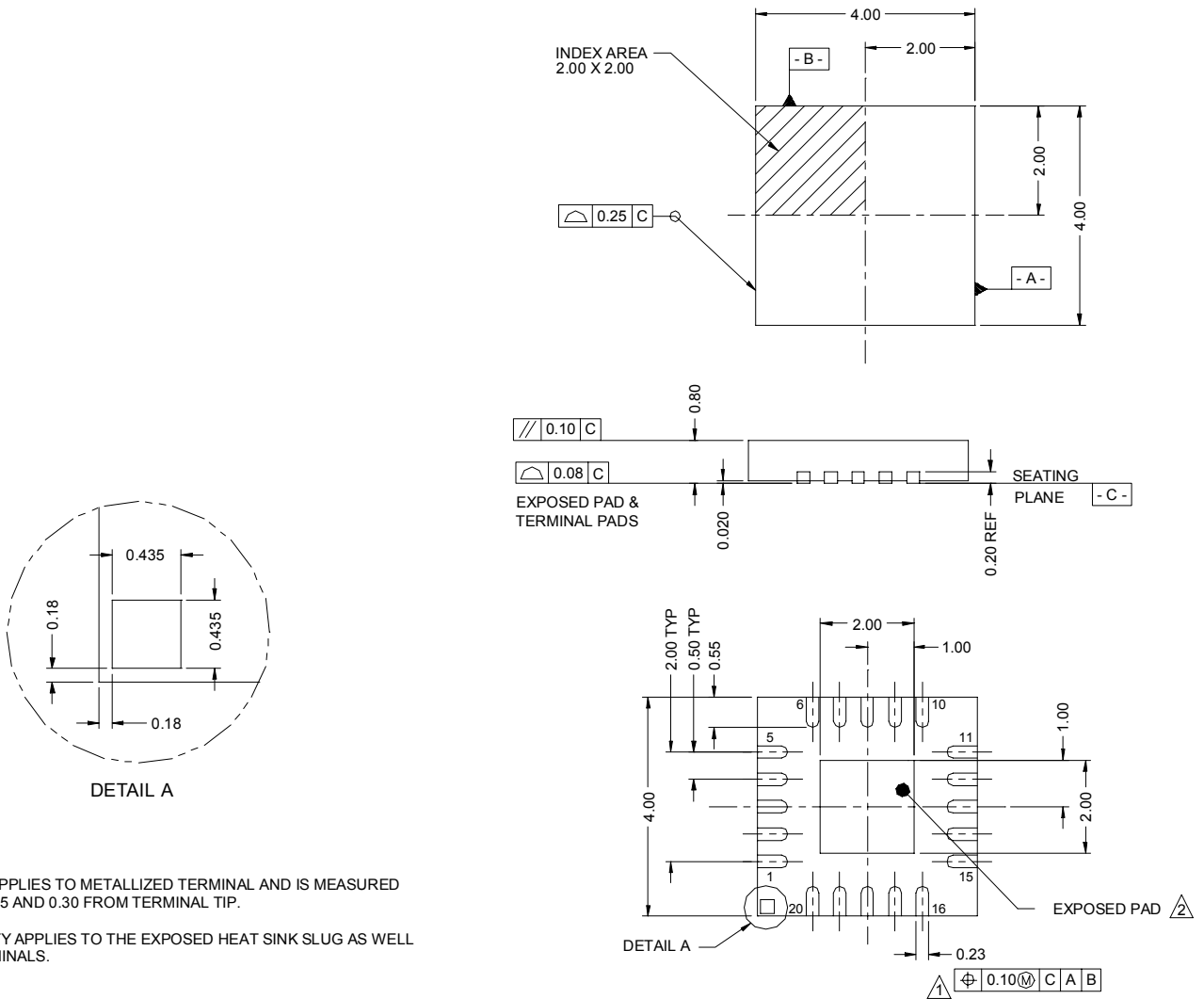


**Figure 9. Evaluation Board Schematic**  
Peregrine Specification 102/0198



**Figure 10. Package Drawing**

20-Lead 4x4 QFN

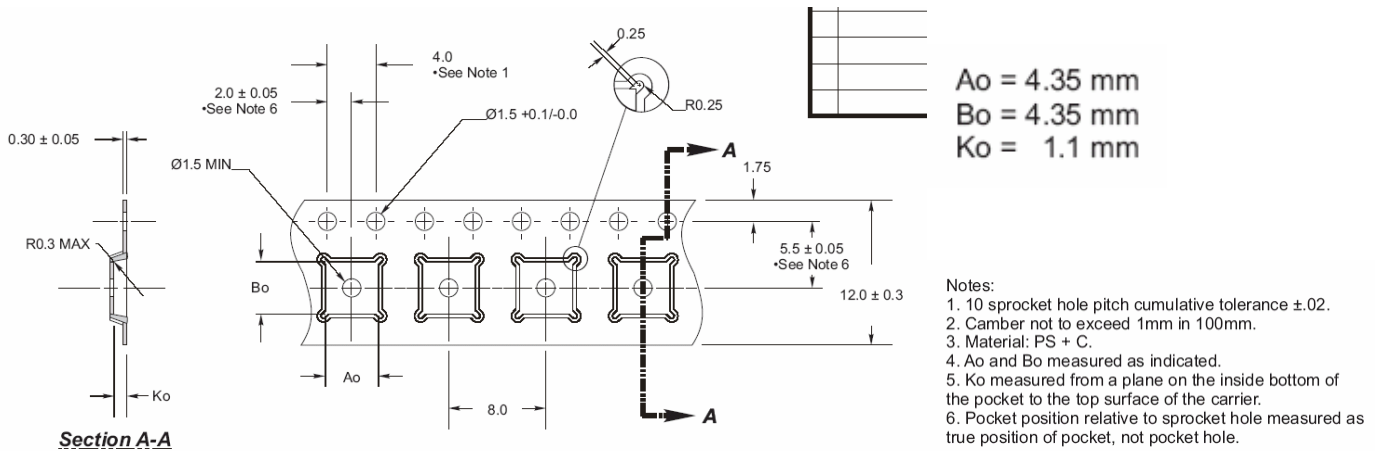


**Figure 11. Marking Specifications**



YYWW = Date Code  
ZZZZZ = Last five digits of PSC Lot Number

**Figure 12. Tape and Reel Drawing**



**Table 6. Ordering Information**

Order Code	Part Marking	Description	Package	Shipping Method
4257-01	4257	PE4257-20QFN 4x4mm-75A	20-lead 4x4mm QFN	75 units / Tube
4257-02	4257	PE4257-20QFN 4x4mm-3000C	20-lead 4x4mm QFN	3000 units / T&R
4257-00	PE4257-EK	PE4257-20QFN 4x4mm-EK	Evaluation Kit	1 / Box
4257-51	4257	PE4257G-20QFN 4x4mm-75A	Green 20-lead 4x4mm QFN	75 units / Tube
4257-52	4257	PE4257G-20QFN 4x4mm-3000C	Green 20-lead 4x4mm QFN	3000 units / T&R

## Sales Offices

### *The Americas*

#### **Peregrine Semiconductor Corporation**

9450 Carroll Park Drive  
San Diego, CA 92121  
Tel: 858-731-9400  
Fax: 858-731-9499

### *Europe*

#### **Peregrine Semiconductor Europe**

Bâtiment Maine  
13-15 rue des Quatre Vents  
F-92380 Garches, France  
Tel: +33-1-4741-9173  
Fax : +33-1-4741-9173

### **Space and Defense Products**

#### **Americas:**

Tel: 858-731-9453

#### **Europe, Asia Pacific:**

180 Rue Jean de Guiramand  
13852 Aix-En-Provence Cedex 3, France  
Tel: +33-4-4239-3361  
Fax: +33-4-4239-7227

### *North Asia Pacific*

#### **Peregrine Semiconductor K.K.**

Teikoku Hotel Tower 10B-6  
1-1-1 Uchisaiwai-cho, Chiyoda-ku  
Tokyo 100-0011 Japan  
Tel: +81-3-3502-5211  
Fax: +81-3-3502-5213

#### **Peregrine Semiconductor, Korea**

#B-2402, Kolon Tripolis, #210  
Geumgok-dong, Bundang-gu, Seongnam-si  
Gyeonggi-do, 463-480 S. Korea  
Tel: +82-31-728-4300  
Fax: +82-31-728-4305

### *South Asia Pacific*

#### **Peregrine Semiconductor, China**

Shanghai, 200040, P.R. China  
Tel: +86-21-5836-8276  
Fax: +86-21-5836-7652

For a list of representatives in your area, please refer to our Web site at: [www.psemi.com](http://www.psemi.com)

## Data Sheet Identification

### **Advance Information**

The product is in a formative or design stage. The data sheet contains design target specifications for product development. Specifications and features may change in any manner without notice.

### **Preliminary Specification**

The data sheet contains preliminary data. Additional data may be added at a later date. Peregrine reserves the right to change specifications at any time without notice in order to supply the best possible product.

### **Product Specification**

The data sheet contains final data. In the event Peregrine decides to change the specifications, Peregrine will notify customers of the intended changes by issuing a DCN (Document Change Notice).

The information in this data sheet is believed to be reliable. However, Peregrine assumes no liability for the use of this information. Use shall be entirely at the user's own risk.

No patent rights or licenses to any circuits described in this data sheet are implied or granted to any third party.

Peregrine's products are not designed or intended for use in devices or systems intended for surgical implant, or in other applications intended to support or sustain life, or in any application in which the failure of the Peregrine product could create a situation in which personal injury or death might occur. Peregrine assumes no liability for damages, including consequential or incidental damages, arising out of the use of its products in such applications.

The Peregrine name, logo, and UTSi are registered trademarks and UltraCMOS and HaRP are trademarks of Peregrine Semiconductor Corp.



SUNSTAR 商斯达实业集团是集研发、生产、工程、销售、代理经销、技术咨询、信息服务等为一体的高科技企业，是专业高科技电子产品生产厂家，是具有 10 多年历史的专业电子元器件供应商，是中国最早和最大的仓储式连锁规模经营大型综合电子零部件代理分销商之一，是一家专业代理和分销世界各大品牌 IC 芯片和电子元器件的连锁经营综合性国际公司，专业经营进口、国产名厂名牌电子元件，型号、种类齐全。在香港、北京、深圳、上海、西安、成都等全国主要电子市场设有直属分公司和产品展示展销窗口门市部专卖店及代理分销商，已在全国范围内建成强大统一的供货和代理分销网络。我们专业代理经销、开发生产电子元器件、集成电路、传感器、微波光电元器件、工控机/DOC/DOM 电子盘、专用电路、单片机开发、MCU/DSP/ARM/FPGA 软件硬件、二极管、三极管、模块等，是您可靠的一站式现货配套供应商、方案提供商、部件功能模块开发配套商。商斯达实业公司拥有庞大的资料库，有数位毕业于著名高校——有中国电子工业摇篮之称的西安电子科技大学（西军电）并长期从事国防尖端科技研究的高级工程师为您精挑细选、量身订做各种高科技电子元器件，并解决各种技术问题。

微波光电部专业代理经销高频、微波、光纤、光电元器件、组件、部件、模块、整机；电磁兼容元器件、材料、设备；微波 CAD、EDA 软件、开发测试仿真工具；微波、光纤仪器仪表。欢迎国外高科技微波、光纤厂商将优秀产品介绍到中国、共同开拓市场。长期大量现货专业批发高频、微波、卫星、光纤、电视、CATV 器件：晶振、VCO、连接器、PIN 开关、变容二极管、开关二极管、低噪晶体管、功率电阻及电容、放大器、功率管、MMIC、混频器、耦合器、功分器、振荡器、合成器、衰减器、滤波器、隔离器、环行器、移相器、调制解调器；光电子器件和组件：红外发射管、红外接收管、光电开关、光敏管、发光二极管和发光二极管组件、半导体激光二极管和激光器组件、光电探测器和光接收组件、光发射接收模块、光纤激光器和光放大器、光调制器、光开关、DWDM 用光发射和接收器件、用户接入系统光收发器件与模块、光纤连接器、光纤跳线/尾纤、光衰减器、光纤适配器、光隔离器、光耦合器、光环行器、光复用器/转换器；无线收发芯片和模组、蓝牙芯片和模组。

更多产品请看本公司产品专用销售网站：

商斯达微波光电产品网：[HTTP://www.rfoe.net/](http://www.rfoe.net/)

商斯达中国传感器科技信息网：<http://www.sensor-ic.com/>

商斯达工控安防网：<http://www.pc-ps.net/>

商斯达电子元器件网：<http://www.sunstare.com/>

商斯达消费电子产品网：<http://www.icasic.com/>

商斯达实业科技产品网：<http://www.sunstars.cn/> 射频微波光电元器件销售热线：

地址：深圳市福田区福华路福庆街鸿图大厦 1602 室

电话：0755-83396822 83397033 83398585 82884100

传真：0755-83376182 (0) 13823648918 MSN: SUNS8888@hotmail.com

邮编：518033 E-mail:szss20@163.com QQ: 195847376

深圳赛格展销部：深圳华强北路赛格电子市场 2583 号 电话：0755-83665529 25059422

技术支持：0755-83394033 13501568376

欢迎索取免费详细资料、设计指南和光盘；产品凡多，未能尽录，欢迎来电查询。

北京分公司：北京海淀区知春路 132 号中发电子大厦 3097 号

TEL: 010-81159046 82615020 13501189838 FAX: 010-62543996

上海分公司：上海市北京东路 668 号上海赛格电子市场 D125 号

TEL: 021-28311762 56703037 13701955389 FAX: 021-56703037

西安分公司：西安高新开发区 20 所(中国电子科技集团导航技术研究所)

西安劳动南路 88 号电子商城二楼 D23 号

TEL: 029-81022619 13072977981 FAX:029-88789382