

VOLTAGE DETECTOR

■ GENERAL DESCRIPTION

The NJU7719 is a low quiescent current voltage detector featuring high precision detection voltage.

The detection voltage is fixed internally with an accuracy of 1.0%.

NJU7719 is Nch. Open Drain output.

■ PACKAGE OUTLINE



NJU7719U

■ FEATURES

- High Precision detection Voltage $\pm 1.0\%$
- Low Quiescent Current $0.8\mu\text{A}$
- Detection Voltage Range $1.3 \sim 6.0\text{V}(0.1\text{V step})$
- Output Circuit Form Nch. Open Drain Type
- Package Outline SOT-89-3 (4.50×3.87×1.50mm)

■ PIN CONFIGURATION

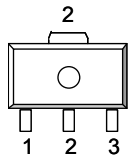

NJU7719U

PIN FUNCTION

1. V_{DD}
2. V_{SS}
3. V_{OUT}

■ EQUIVALENT CIRCUIT

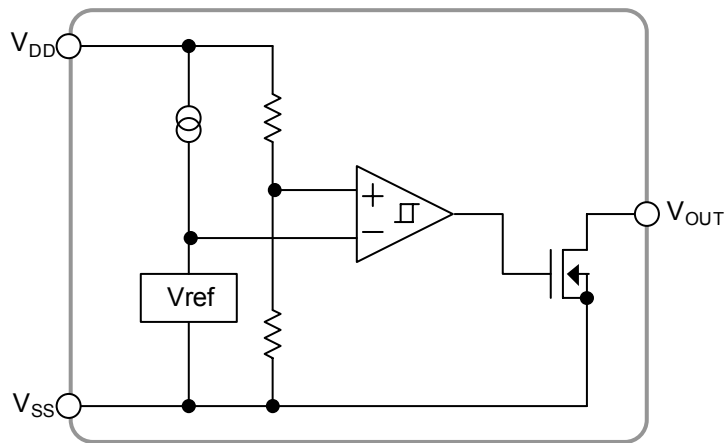

■ DETECTION VOLTAGE RANK LIST

Device Name	V_{DET}	Device Name	V_{DET}
NJU7719U21	2.1V	NJU7719U34	3.4V
NJU7719U23	2.3V	NJU7719U39	3.9V
NJU7719U27	2.7V	NJU7719U42	4.2V
NJU7719U29	2.9V	NJU7719U45	4.5V
NJU7719U32	3.2V	NJU7719U47	4.7V

NJU7719

■ ABSOLUTE MAXIMUM RATINGS (Ta=25°C)

PARAMETER	SYMBOL	RATINGS	UNIT
Input Voltage	V _{DD}	+10	V
Output Voltage	V _{OUT}	V _{SS} -0.3 ~ +10	V
Output Current	I _{OUT}	50	mA
Power Dissipation	P _D	350	mW
Operating Temperature	Topr	-40 ~ +85	°C
Storage Temperature	Tstg	-40 ~ +125	°C

■ ELECTRICAL CHARACTERISTICS (Ta=25°C)

PARAMETER	SYMBOL	TEST CONDITION	MIN.	TYP.	MAX.	UNIT	
Detection Voltage	V _{DET}		-1.0%	—	+1.0%	V	
Hysteresis Voltage	V _{HYS}		V _{DET} ×0.03	V _{DET} ×0.05	V _{DET} ×0.08	V	
Quiescent Current	I _{SS}	V _{DD} =V _{DET} +1V	V _{DET} =1.3V~1.7V Version	—	0.5	1.0	μA
			V _{DET} =1.8V~6.0V Version	—	0.8	1.6	μA
Output Current	I _{OUT}	Nch, V _{DS} =0.5V	V _{DD} =1.2V	0.75	2.0	—	mA
			V _{DD} =2.4V (≥2.7V Version)	4.5	7.0	—	mA
Output Leak Current	I _{LEAK}	V _{DD} =V _{OUT} =9V	—	—	0.1	μA	
Detection Voltage Temperature Coefficient	ΔV _{DET} /ΔTa	Ta=0 ~ +85°C	—	±100	—	ppm/°C	
Operating Voltage (*note 1)	V _{DD}	R _L =100kΩ	0.8	—	9	V	

(*note 1): The minimum Operating Voltage(V_{OPL}) indicates the same value of the output voltage(V_{OUT}) on condition that V_{OUT} becomes 10% or less of the input voltage(V_{DD}).

■ TEST CIRCUIT

① COMMON TEST CIRCUIT

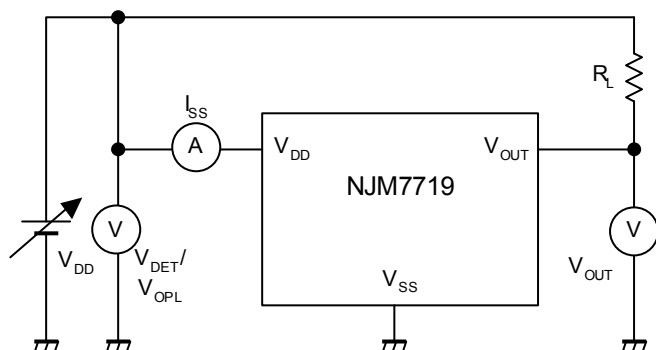

② Output Current/Output Leak Current TEST CIRCUIT

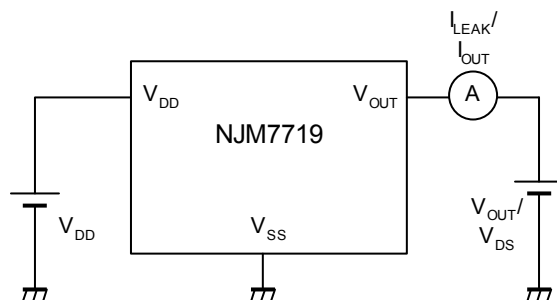

■ TYPICAL APPLICATION

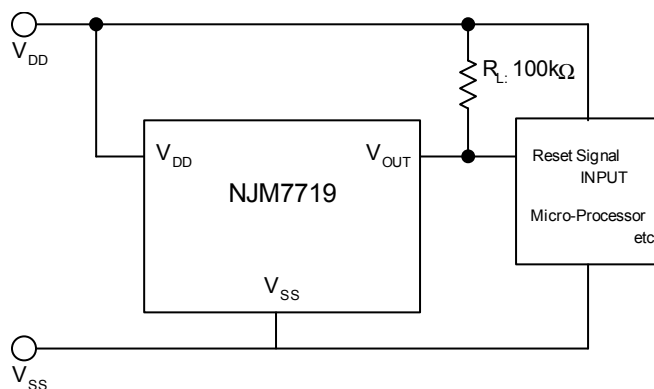

■ TYPICAL CHARACTERISTICS

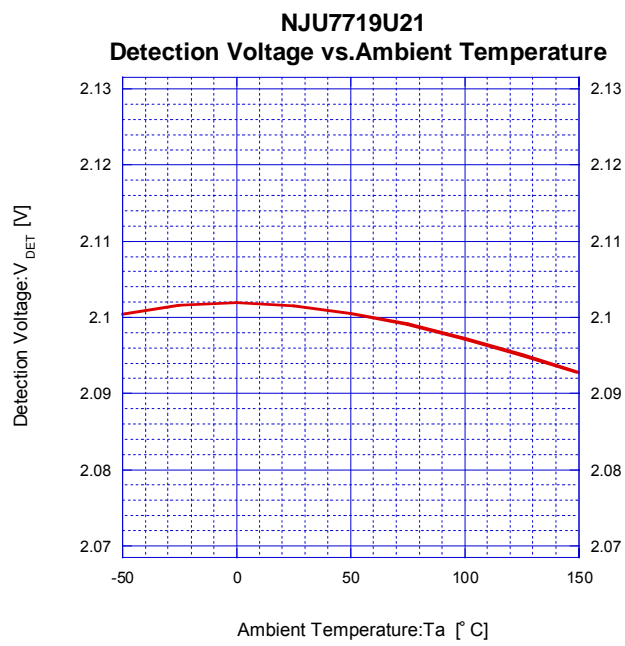
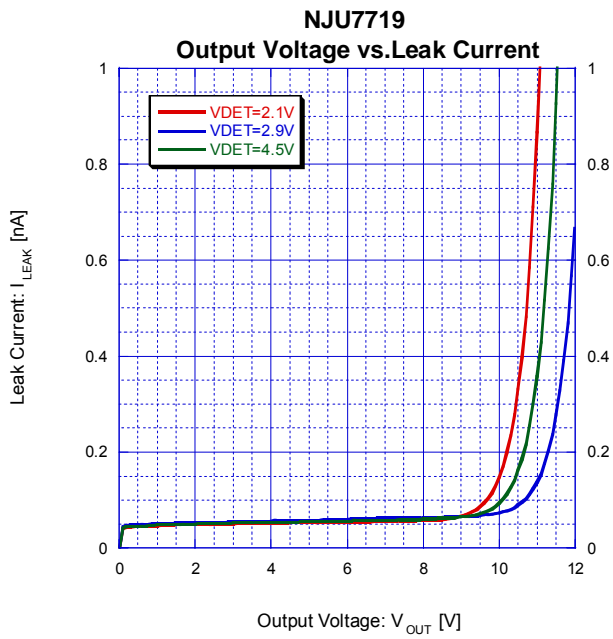
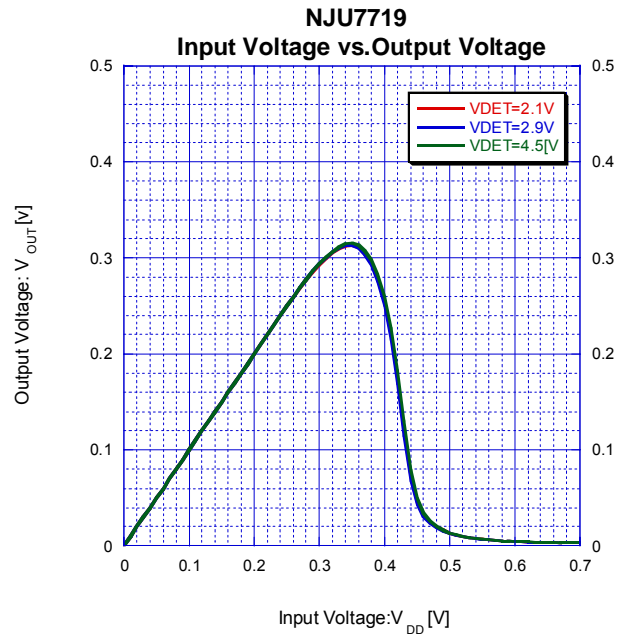
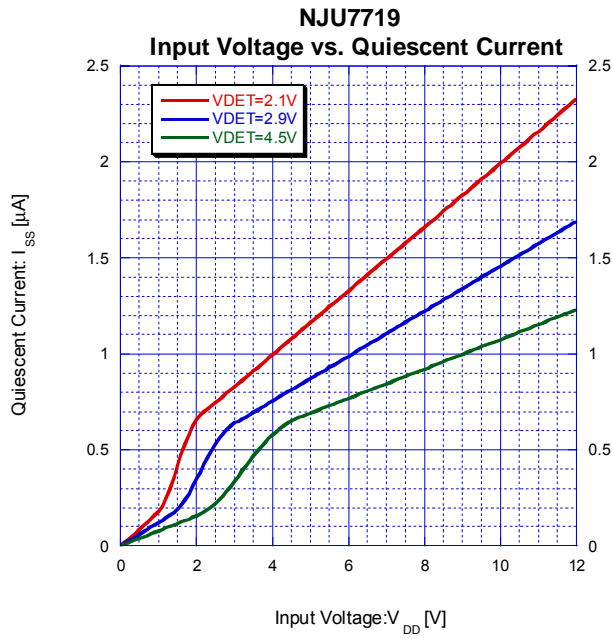

TYPICAL CHARACTERISTICS

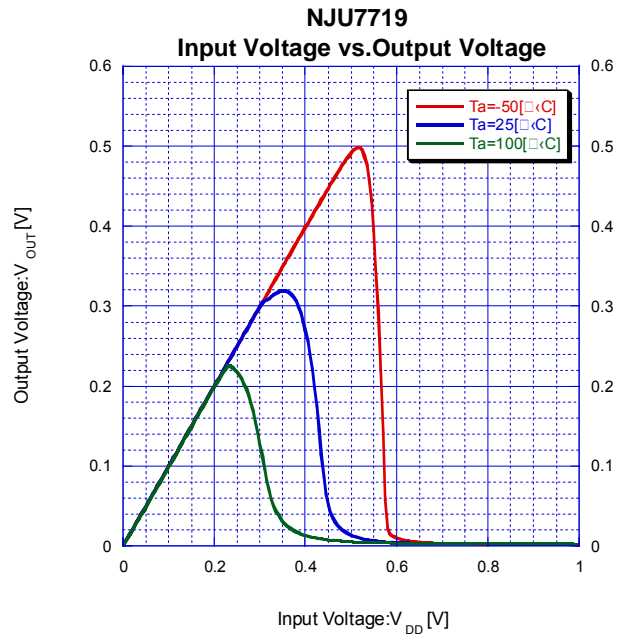
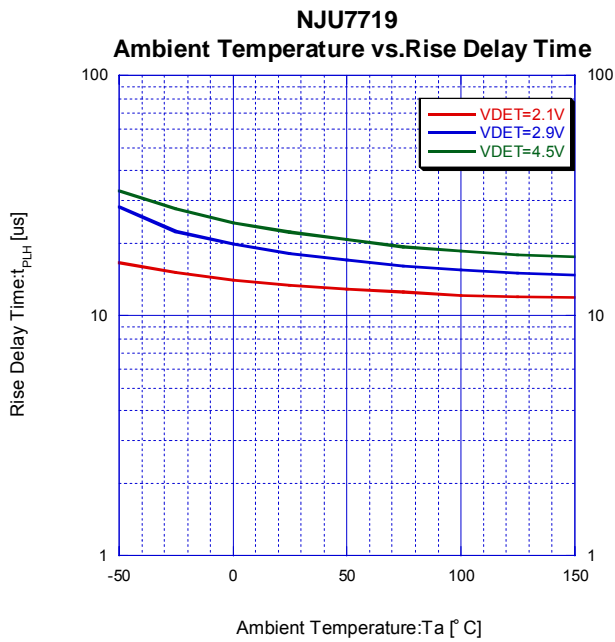
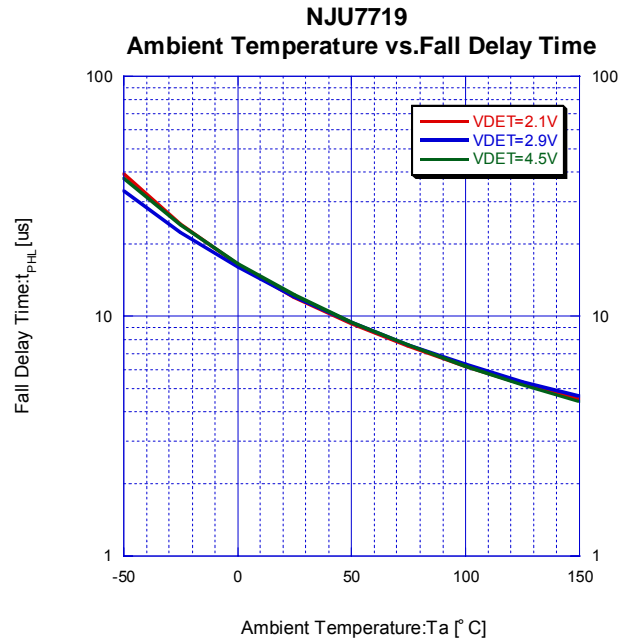
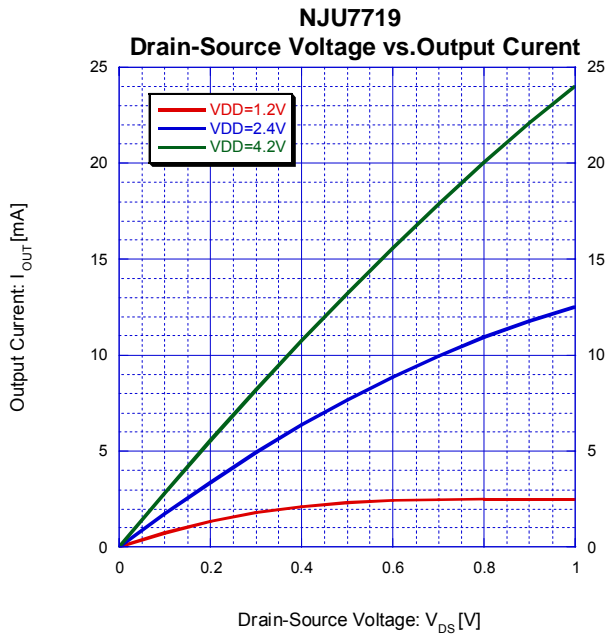

■ TYPICAL CHARACTERISTICS

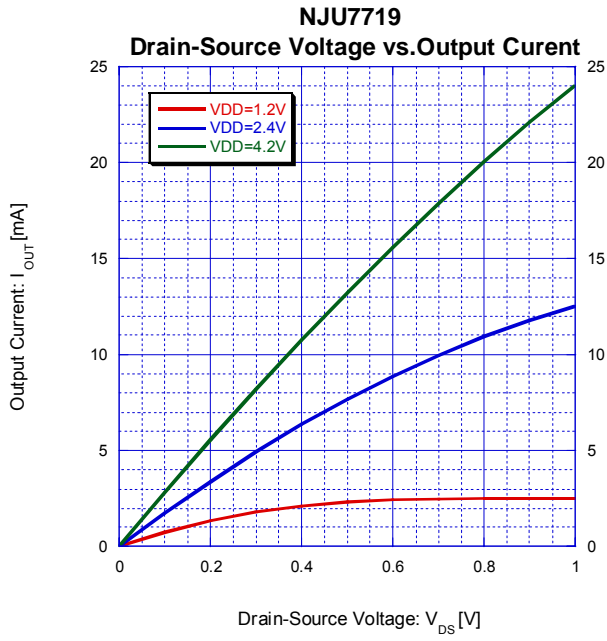

■ TYPICAL CHARACTERISTICS

Transient Response

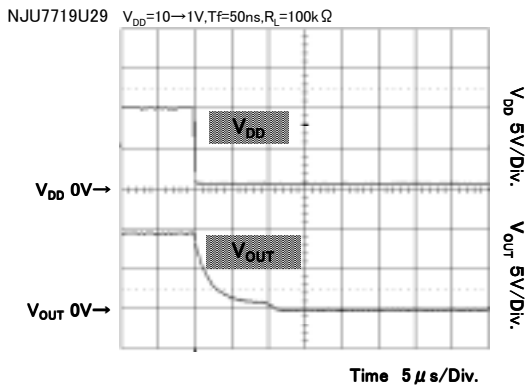

Transient Response

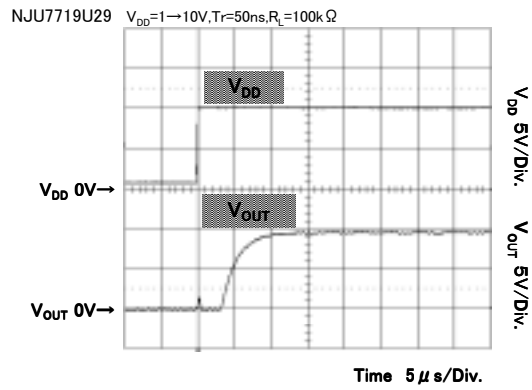

[CAUTION]

The specifications on this databook are only given for information, without any guarantee as regards either mistakes or omissions. The application circuits in this databook are described only to show representative usages of the product and not intended for the guarantee or permission of any right including the industrial rights.