

VOLTAGE DETECTOR

■ GENERAL DESCRIPTION

NJM2405 is a dual comparator, including the high precision reference voltage circuit. Both channels have hysteresis pins, so it could provide the hysteretic function for systems.

It has the wide range of operating voltage and works with less current consumption, so that it is suitable for detecting abnormal conditions, to change over to back up memories when the voltage drops off in operation.

■ PACKAGE OUTLINE



NJM2405M

■ FEATURES

- Operating Voltage (2.5V to 20V)
- Low Operating Current
- Internal Low Reference Voltage
- Adjustable Hysteresis Voltage
- Package Outline DMP8
- Bipolar Technology

■ PIN CONFIGURATION

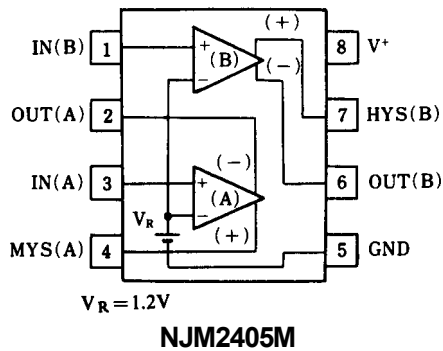

■ EQUIVALENT CIRCUIT

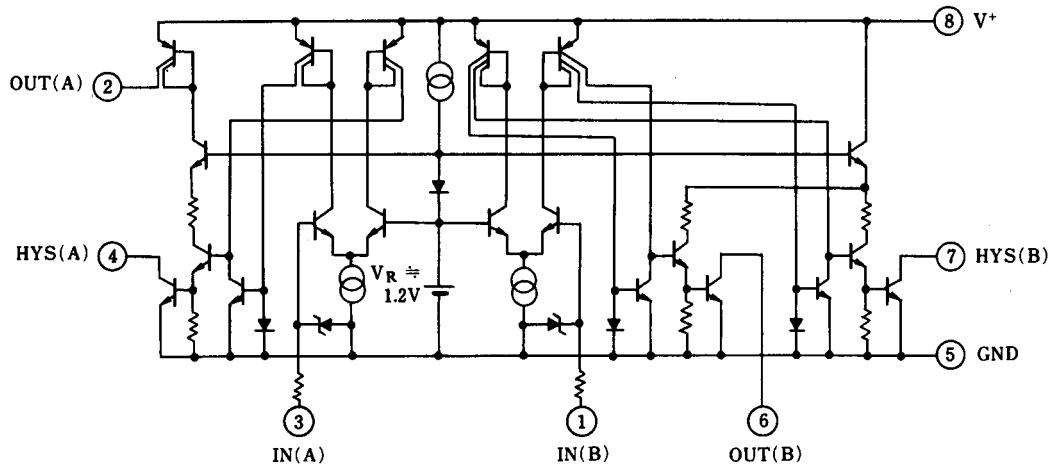

■ ABSOLUTE MAXIMUM RATINGS

(T_a = 25°C)

PARAMETER	SYMBOL	RATINGS	UNIT
Supply Voltage	V ⁺	21	V
Output Voltage	V _O	21	V
Output Current	I _O	50	mA
Input Voltage	V _{IN}	-0.3 to +6.5	V _{dc}
Power Dissipation	P _D	300	mW
Operating Temperature Range	T _{opr}	-20 to +75	°C
Storage Temperature Range	T _{stg}	-40 to +125	°C

■ ELECTRICAL CHARACTERISTICS

(V⁺ = 5V, T_a = 25°C)

PARAMETER	SYMBOL	TEST CONDITION	MIN.	TYP.	MAX.	UNIT
Operating Current	I _{CCH}	V ⁺ = 20V, V _{IH} = 1.5V	-	250	400	μA
	I _{CCL}	V ⁺ = 20V, V _{IL} = 1.0V	-	400	600	μA
Threshold Voltage	V _{TH}	I _O = 2mA, V _O = 1V	1.15	1.20	1.25	V
Threshold Voltage Deviation vs Supply Voltage	ΔV _{TH1}	2.5V ≤ V ⁺ ≤ 5.5V	-	3	12	mV
	ΔV _{TH2}	4.5V ≤ V ⁺ ≤ 40V	-	10	40	mV
Offset Voltage between Normal Output and Hysteresis Output		I _O (A) = 20μA, V _O (A) = 3V, I _H (A) = 4.5mA, V _H (A) = 2V	-	2.0	-	mV
		I _O (B) = 3mA, V _O (B) = 2V, I _H (B) = 3mA, V _H (B) = 2V	-	2.0	-	mV
Threshold Voltage Temperature coefficient		-20°C ≤ T _a ≤ 70°C	-	±0.05	-	mV/°C
Threshold Voltage Difference Between Channels			-10	-	10	mV
Input Current	I _{IL}	I _{IL} = 1.0V	-	5	-	nA
	I _{IH}	V _{IH} = 1.5V	-	100	500	nA
Output Leak Current	I _{OH} (A)	V ⁺ = 20V, V _O (A) = 0V, V _{IH} = 1.5V	-	-	0.1	μA
	I _{OH} (B)	V _O (B) = 20V, V _{IL} = 1.0V	-	-	1	μA
Hysteresis Output leak Current	I _{IH} (A)	V _H (A) = 20V, V _{IH} = 1.5V	-	-	1	μA
	I _{IH} (B)	V _H (B) = 20V, V _{IH} = 1.5V	-	-	1	μA
Output Source Current	I _{OL} (A)	V _O (A) = 0V, V _{IL} = 1.0V	40	80	-	μA
Output Sink Current	I _{OL} (B)	V _O (B) = 1.0V, V _{IH} = 1.5V	4	10	-	mA
Hysteresis Current	I _{HL} (A)	V _H (A) = 1.0V, V _{IL} = 1.0V	6	12	-	mA
	I _{HL} (B)	V _H (B) = 1.0V, V _{IL} = 1.0V	4	10	-	mA
Output Saturation Voltage	V _{OL} (A)	I _O (A) = 20μA, V _{IL} = 1.0V	-	50	200	mV
	V _{OL} (B)	I _O (B) = 3.0mA, V _{IH} = 1.5V	-	120	400	mV
Hysteresis Output Saturation Voltage	V _{HL} (A)	I _H (A) = 4.5mA, V _{IL} = 1.0V	-	120	400	mV
	V _{HL} (B)	I _H (B) = 3.0mA, V _{IL} = 1.0V	-	120	400	mV
Delay Time	t _{PHL}	R _L = 5kΩ	-	2	-	μs
	t _{PLH}	R _L = 5kΩ	-	3	-	μs

■ GENERAL OPERATING INFORMATION (Operation Principle)

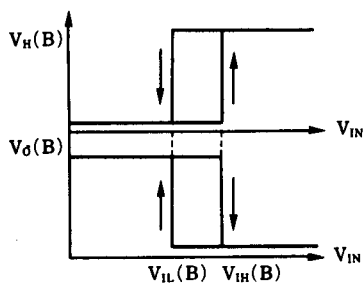
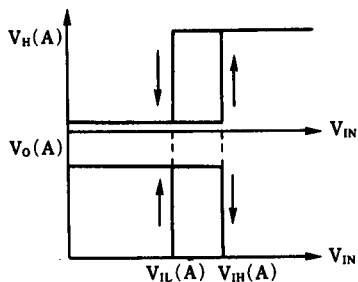
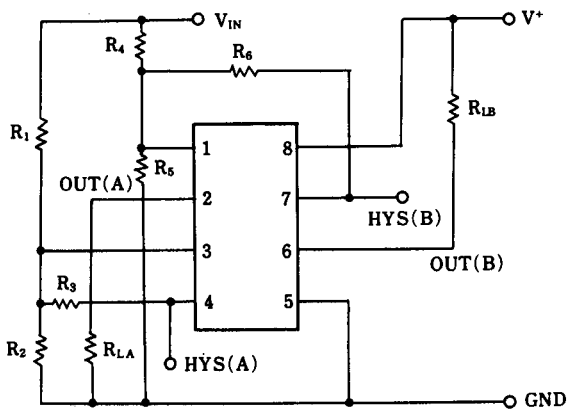

Relational Function (Attention)

$$V_{IH}(A) = \left(1 + \frac{R_1}{R_2 // R_3}\right) V_R$$

$$V_{IL}(A) = \left(1 + \frac{R_1}{R_2}\right) V_R$$

$$V_{IH}(B) = \left(1 + \frac{R_4}{R_5 // R_6}\right) V_R$$

$$V_{IL}(B) = \left(1 + \frac{R_4}{R_5}\right) V_R$$

(note) $V_R \doteq V_{TH} (\doteq 1.20V)$

$$R_2 // R_3 = \frac{R_2 R_3}{R_2 + R_3}$$

$$R_5 // R_6 = \frac{R_5 R_6}{R_5 + R_6}$$

[CAUTION]

The specifications on this databook are only given for information, without any guarantee as regards either mistakes or omissions. The application circuits in this databook are described only to show representative usages of the product and not intended for the guarantee or permission of any right including the industrial rights.