

STEREO MODULATOR

■ GENERAL DESCRIPTION

The NJM2035 is an integrated circuit used to generate a stereo composite signal and obtain switching output and 19kHz pilot signal due to two input audio signal and 38kHz X-tal and a few external CR.

The NJM2035 operates at 1.5V battery typically and even at 1.2V obtains separation more than 25dB.

NJM2035 can generate stereo multiplex signal easily by combination battery generator section.

■ PACKAGE OUTLINE

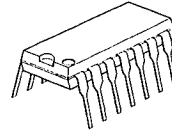

NJM2035D

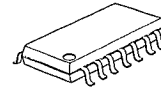

NJM2035M

■ FEATURES

- Low Operating Voltage ($V^+ \geq 1.0V$)
- Low Operating Current ($I_{cc} \leq 3.0mA$)
- High Separation ($SEP \geq 25dB$)
- Separation Adjustable
- Package Outline DIP14, DMP14
- Bipolar Technology

■ BLOCK DIAGRAM

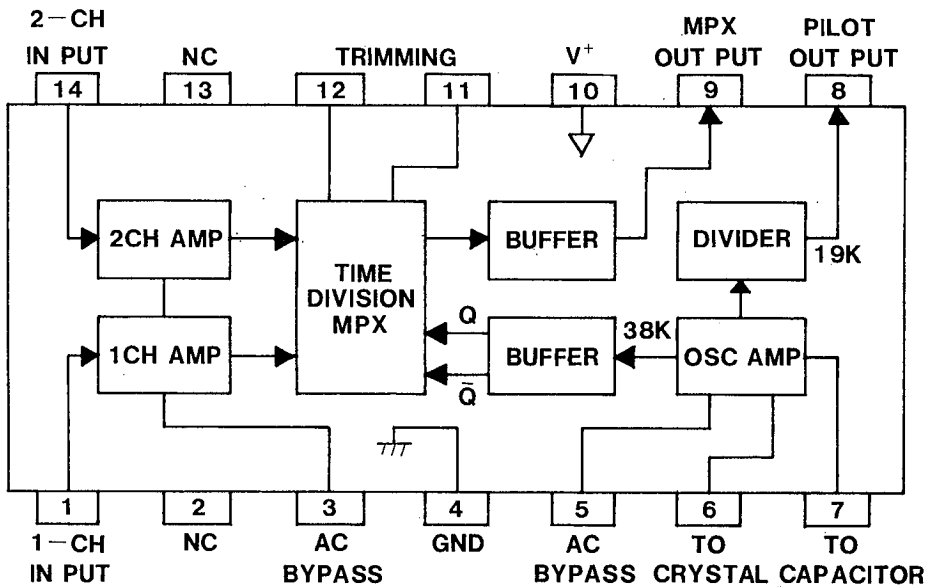

NJM2035D
NJM2035M

5

■ ABSOLUTE MAXIMUM RATINGS

(Ta=25°C)

PARAMETER	SYMBOL	RATINGS	UNIT
Supply Voltage	V*	3.6	V
Power Dissipation	P _D	(DIP14) 500 (DMP14) 300	mW
Operating Temperature Range	T _{opr}	-20~+75	°C
Storage Temperature Range	T _{stg}	-40~+125	°C

■ ELECTRICAL CHARACTERISTICS

(Ta=25°C, V*=1.5V)

PARAMETER	SYMBOL	TEST CONDITION	MIN.	TYP.	MAX.	UNIT
Operating Current	I _{CC}	R _L = ∞	—	1.8	3.0	mA
Input Impedance	Z _{IN}	f=1kHz	—	420	—	Ω
Maximum Input Current	I _{IM}		—	4.1	—	μA
Voltage Gain	G _V	R _S = 2kΩ, R _L = 10kΩ	16	20	—	dB
Difference Gain Between Channels	G _{VD}	R _S = 2kΩ, R _L = 10kΩ	—	—	2.0	dB
Equivalent Input Noise Voltage	V _{NI}	R _S = 2kΩ, R _L = 10kΩ, A _{WEIGHTED}	—	—	2.0	μVrms
Maximum Output Voltage Swing	V _{OM}	R _S = 2kΩ, R _L = 10kΩ	140	200	—	mVp-p
Output Impedance	Z _O	f=1kHz	—	230	—	Ω
Pilot Output Voltage	V _{OP}	R _L = 150kΩ	—	240	—	mV
Pilot Output Impedance	R _{OP}		—	3	—	kΩ
Separation	SEP	f=1kHz at Application Circuit	—	40	—	dB
Internal Separation Compensation	S.C		—	-19	—	dB

5

■ TYPICAL CHARACTERISTICS (*: BY APPLICATION CIRCUIT)

Operating Current vs. Operating Voltage

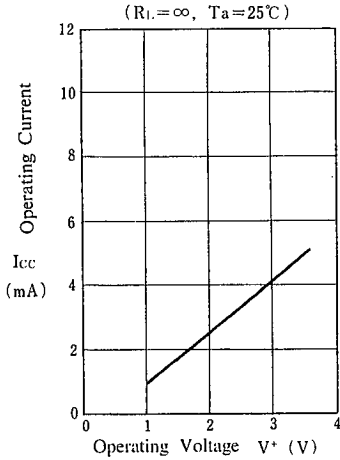

Voltage Gain vs. Input Series Resistance

($f = 1\text{kHz}$, $R_L = 10\text{k}\Omega$, $T_a = 25^\circ\text{C}$)

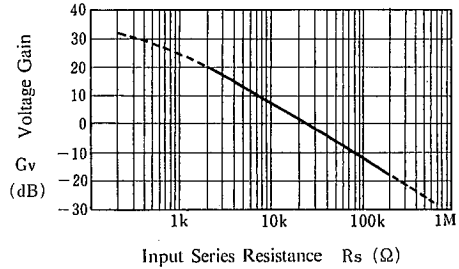

Pilot Output Voltage vs. Operating Voltage

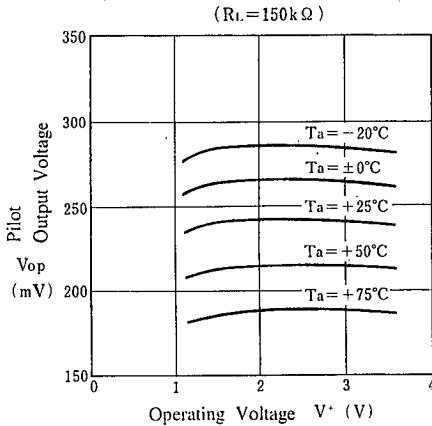

※ Separation vs. Frequency

($V_{IN} = 150\text{mV}$, $T_a = 25^\circ\text{C}$)

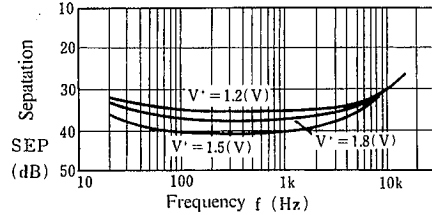

※ Total Harmonic Distortion vs. Modulation

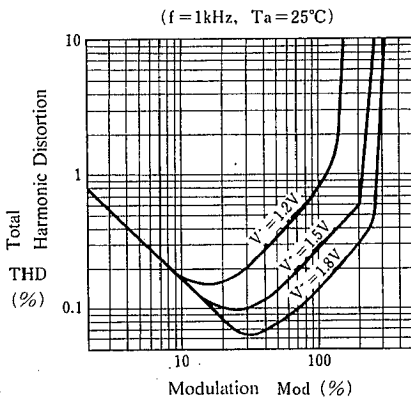

MPX Maximum Output Voltage Swing vs. Operating Voltage

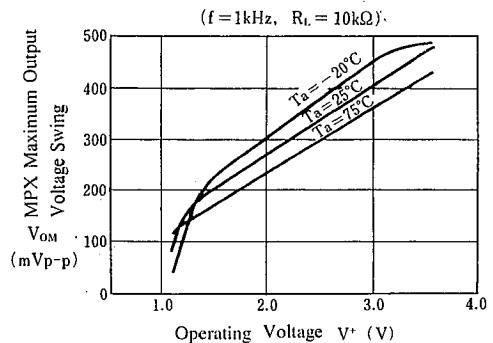

■ APPLICATION CIRCUIT EXAMPLES

The following block diagram shows an FM stereo transmitter using NJM2035. Input a current mode signal, because two inputs of NJM2035 are of a low impedance type. Also, the pre-emphasis can be applied at a time constant of C_L and R_L by utilizing this characteristic.

Input series resistance R_s of low band can be obtained from the maximum input voltage $V_{IM(P-P)}$ and the maximum input current I_{IM} of NJM2035.

$$R_s = V_{IM} / 2I_{IM} \quad (R_s = R_1 + R_2)$$

However, the circuit for stabilized operation, R_2 must stay between 2~12k Ω , and also, in order to get enough pre-emphasis characteristics, R_1 is required to maintain within the range of $5 \times R_2 \sim 10 \times R_2$. Transmitting on FM stereo, it is advisable to set the pre-emphasis time C_1 , R_1 at 50 μ s. When it is large maximum input voltage and could not satisfy R_1 , R_2 condition, it is important to attenuate the input voltage beforehand, like that of Fig.2 the circuit example. In this case however, special care must be taken for not making the pre-emphasis time control influenced from the attenuator.

In order to get the important composit signals for stereo transmitting, the MPX signal and the pilot signal which were delivered output at each different pins, to be mixed (MIX) and the ratio is decided by the modulation of NJM2035 the maximum output voltage V_{OM} that means that, it can be decided by how much percent to be set the ratio of the maximum modulation. The maximum modulation takes the essential part to decide the dynamic range and to be set with consideration of modulation sensitivity of FM transmitter, S/N and also with the linearity of receiver. In general, 200% modulation ($\Delta f = \pm 150\text{MHz}$) will give the satisfacting result.

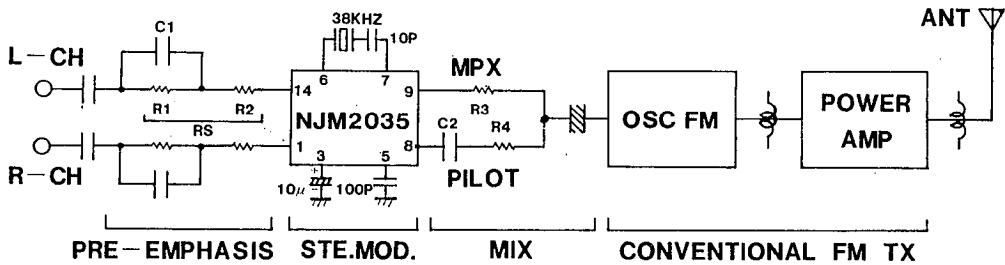

Fig1

5

RECOMMENDED APPLICATION CIRCUIT & EACH WAVEFORM

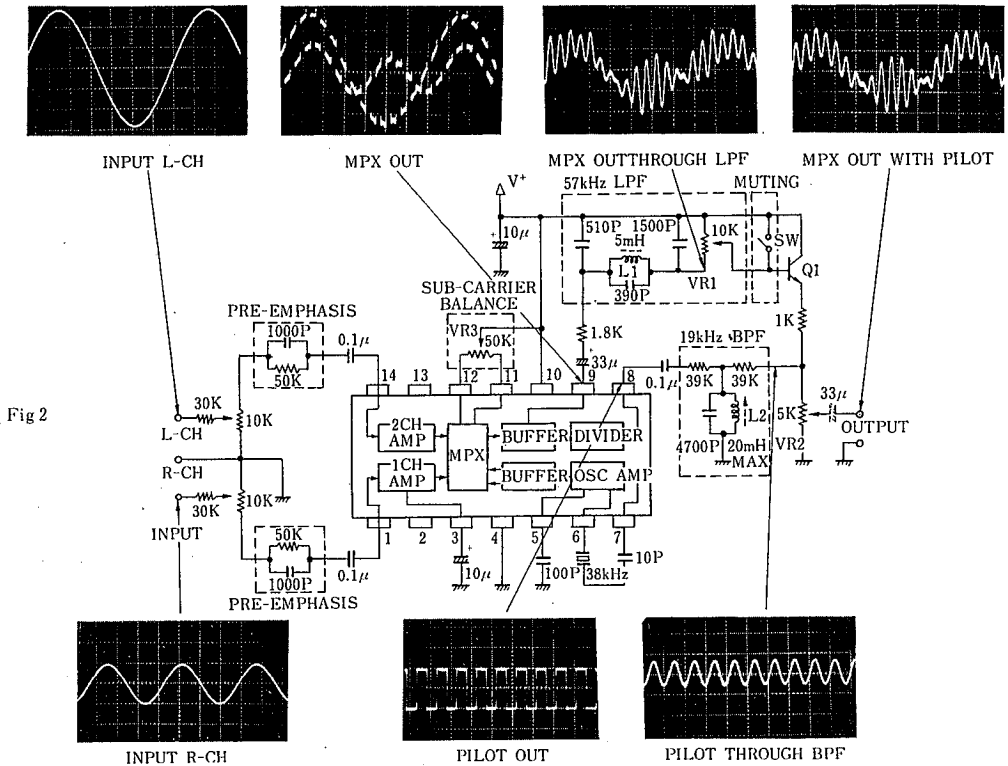

Fig 2

The adjustment procedure in the recommended application circuit.

- ① Sub-carrier leakage can be minimized by the adjustment of VR_3 .
 - ② The maximum output voltage of pilot can be obtained by the adjustment of L_2
 - ③ VR_2 adjustment of the pilot will help to bring the modulation ratio a little over 10% ($\Delta f = \pm 7.5\text{kHz}$)
 - ④ The modulation ratio can be increased as much as 30% at VR_1 by putting designed standard input.
 - ⑤ By putting only the input for L-channel, and making re-adjustment of L_2 , so that the maximum power of output at L-channel can be obtained at the receiver's side. (19kHz phase adjustment)
- Against 100% modulation at the recommended circuit S/N at A curve +15kHz LPF 77dB, and at 15kHz LPF 67dB approximately can be obtained.

Recommended Application Circuit & Each Waveform on the other hand, the pilot level is to be modulated 10% with no connection of Max. modulation ratio, so that the following relation can be set.

$$\frac{R_0 + R_3}{R_{OP} + R_4} \times \frac{2\sqrt{2} V_{OP}}{V_{OM}} = \frac{10}{200}$$

However, for the stability in operation, it is advisable to control MPX signal loading more than 1.8kΩ, and the pilot signal loading more than 39kΩ.

As in example of Fig.1 Simplified Application Circuit, when making the rectangular wave like output to be the composite signal itself, the separating effect shall be reduced due to influence by harmonic components included in MPX signal, so that it requires to make the adjustment to be able to get ample separation of pilot signal phase by the operation of C_2 , R_4 , time signal. In this procedure, there is defective side of getting slightly difference of the best position of separating effect depending upon the tuner of receiver's side, however, when $R_3 = 2\text{k}\Omega$, $R_4 = 150\text{k}\Omega$, $C_2 = 330\text{pF}$ then the ample separation can be obtained practically.

Special care must be taken that the pilot signal's the third harmonic wave 57kHz will be the cause of dangerous beating.

Fig 2 indicates the example of recommended application circuit of stereo modulation when NJM2035 is used. As explained in the waveform, high quality composite signal can be obtained by only putting a simple filter beforehand. Then the previously mentioned problems can be improved a great deal.

The input is modulated 30% at AUX level (150mV) — changeable of +3dB — ∞ by volume control.

VR_1 corresponds to the fluctuation of GV feature of NJM2035, and also for fluctuation of modulation sensitivity of FM modulation circuit which is connected after VR_2 .

VR_3 is to make minimum adjustment of 38kHz sub-carrier leakage, and with this adjustment, it can control until about -50dB in comparing to 100% modulation level.

MEMO

[CAUTION]

The specifications on this databook are only given for information, without any guarantee as regards either mistakes or omissions. The application circuits in this databook are described only to show representative usages of the product and not intended for the guarantee or permission of any right including the industrial rights.

SUNSTAR 商斯达实业集团是集研发、生产、工程、销售、代理经销、技术咨询、信息服务等为一体的高科技企业，是专业高科技电子产品生产厂家，是具有 10 多年历史的专业电子元器件供应商，是中国最早和最大的仓储式连锁规模经营大型综合电子零部件代理分销商之一，是一家专业代理和分销世界各大品牌 IC 芯片和电子元器件的连锁经营综合性国际公司，专业经营进口、国产名厂名牌电子元件，型号、种类齐全。在香港、北京、深圳、上海、西安、成都等全国主要电子市场设有直属分公司和产品展示展销窗口门市部专卖店及代理分销商，已在全国范围内建成强大统一的供货和代理分销网络。我们专业代理经销、开发生产电子元器件、集成电路、传感器、微波光电元器件、工控机/DOC/DOM 电子盘、专用电路、单片机开发、MCU/DSP/ARM/FPGA 软件硬件、二极管、三极管、模块等，是您可靠的一站式现货配套供应商、方案提供商、部件功能模块开发配套商。商斯达实业公司拥有庞大的资料库，有数位毕业于著名高校——有中国电子工业摇篮之称的西安电子科技大学（西军电）并长期从事国防尖端科技研究的高级工程师为您精挑细选、量身订做各种高科技电子元器件，并解决各种技术问题。

微波光电部专业代理经销高频、微波、光纤、光电元器件、组件、部件、模块、整机；电磁兼容元器件、材料、设备；微波 CAD、EDA 软件、开发测试仿真工具；微波、光纤仪器仪表。欢迎国外高科技微波、光纤厂商将优秀产品介绍到中国、共同开拓市场。长期大量现货专业批发高频、微波、卫星、光纤、电视、CATV 器件：晶振、VCO、连接器、PIN 开关、变容二极管、开关二极管、低噪晶体管、功率电阻及电容、放大器、功率管、MMIC、混频器、耦合器、功分器、振荡器、合成器、衰减器、滤波器、隔离器、环行器、移相器、调制解调器；光电子元件和组件：红外发射管、红外接收管、光电开关、光敏管、发光二极管和发光二极管组件、半导体激光二极管和激光器组件、光电探测器和光接收组件、光发射接收模块、光纤激光器和光放大器、光调制器、光开关、DWDM 用光发射和接收器件、用户接入系统光收发器件与模块、光纤连接器、光纤跳线/尾纤、光衰减器、光纤适配器、光隔离器、光耦合器、光环行器、光复用器/转换器；无线收发芯片和模组、蓝牙芯片和模组。

更多产品请看本公司产品专用销售网站：

商斯达中国传感器科技信息网：<http://www.sensor-ic.com/>

商斯达工控安防网：<http://www.pc-ps.net/>

商斯达电子元器件网：<http://www.sunstare.com/>

商斯达微波光电产品网：[HTTP://www.rfoe.net/](http://www.rfoe.net/)

商斯达消费电子产品网：<http://www.icasic.com/>

商斯达实业科技产品网：<http://www.sunstars.cn/> 微波元器件销售热线：

地址：深圳市福田区福华路福庆街鸿图大厦 1602 室

电话：0755-82884100 83397033 83396822 83398585

传真：0755-83376182 (0) 13823648918 MSN: SUNS8888@hotmail.com

邮编：518033 E-mail:szss20@163.com QQ: 195847376

深圳赛格展销部：深圳华强北路赛格电子市场 2583 号 电话：0755-83665529 25059422

技术支持：0755-83394033 13501568376

欢迎索取免费详细资料、设计指南和光盘；产品凡多，未能尽录，欢迎来电查询。

北京分公司：北京海淀区知春路 132 号中发电子大厦 3097 号

TEL: 010-81159046 82615020 13501189838 FAX: 010-62543996

上海分公司：上海市北京东路 668 号上海赛格电子市场 D125 号

TEL: 021-28311762 56703037 13701955389 FAX: 021-56703037

西安分公司：西安高新开发区 20 所(中国电子科技集团导航技术研究所)

西安劳动南路 88 号电子商城二楼 D23 号

TEL: 029-81022619 13072977981 FAX:029-88789382