

Drive circuit basics

For a given size of a stepper motor, a limited space is available for the windings. In the process of optimizing a stepper motor drive system, an efficient utilization of the available winding space as well as a matching of driver and winding parameters are of great importance.

This chapter discusses the basic electrical characteristics of a stepper motor winding. Special attention is given to driving configurations and current control methods.

Winding resistance and inductance

The windings of a stepper motor are made up of several turns of copper wire. The wire is wound on plastic bobbin, which allows separate manufacturing of the winding, the stator and other mechanical parts. At a final stage of production the bobbin is mounted around the stator poles.

Resistance and inductance are two inherent physical properties of a winding, or any coil. These two basic factors also limit the possible performance of the motor.

The resistance of the windings is responsible for the major share of the power loss and heat up of the motor. Size and thermal characteristics of the winding and the motor limit the maximum allowable power dissipated in the winding. The power loss is given by:

$$P_R = R \cdot I_M^2$$

It is important to note that a motor should be used at its maximum power dissipation to be efficient. If a motor is running below its power dissipation limit, it means that it could be replaced by a smaller size motor, which most probably is less expensive.

Inductance makes the motor winding oppose current changes, and therefore limits high speed operation. Figure 2 shows the electrical characteristics of an inductive-resistive circuit. When a voltage is connected to the winding the current rises according to the equation

$$I(t) = (V/R) \cdot (1 - e^{-t \cdot R/L})$$

Initially the current increases at a rate of

$$\frac{dI}{dt}(0) = V/L$$

The rise rate decreases as the current approaches the final level:

$$I_{MAX} = V/R$$

The value of $t_e = L/R$ is defined as the electrical time constant of the circuit. t_e is the time until the current reaches 63% ($1 - 1/e$) of its final value.

When the inductive-resistive circuit is disconnected and shorted at the instant $t = t_1$, the current starts to decrease:

$$I(t) = (V/R) \cdot e^{-(t-t_1) \cdot R/L}$$

at an initial rate of

$$I(t) = -V/L$$

When a square wave voltage is applied to the winding, which is the case when fullstepping a stepper motor, the current waveform will be smoothed. Figure 3 shows the current at three different frequencies. Above a certain frequency (B) the current never reaches its maximum value (C). As the torque of the motor is approximately proportional to the current, the maximum torque will be reduced as the stepping frequency increases.

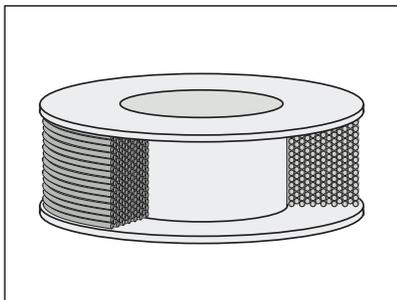

Figure 1. Winding of a typical Permanent Magnet stepper motor.

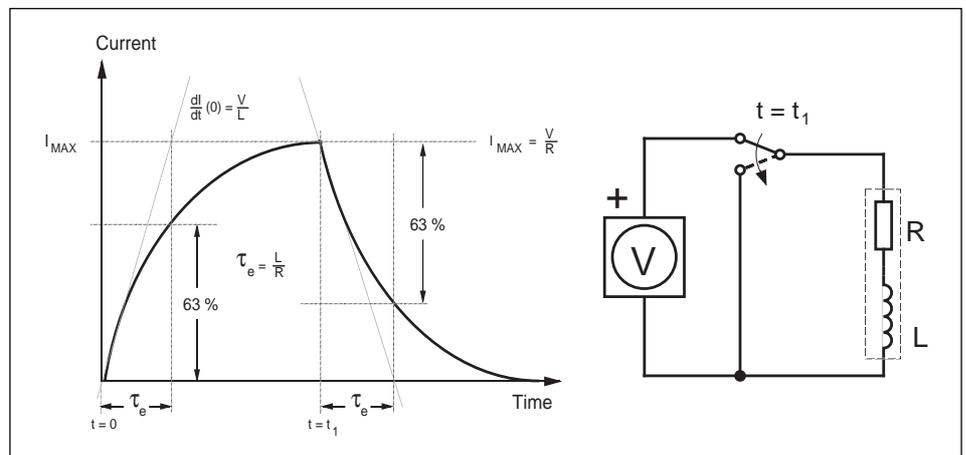

Figure 2. Current wave form in an inductive-resistive circuit.

To overcome the inductance and gain high speed performance of the motor two possibilities exist: Increase the current rise rate and/or decrease the time constant. As an increased resistance always results in an increased power loss, it is preferably the ratio V/L that should be increased to gain high speed performance.

To drive current through the winding, we should:

- use as high voltage as possible
- keep the inductance low.

Accordingly, a low inductance/resistance motor has a higher current rating. As the maximum current is limited by the driver, we find that high performance is highly dependant on the choice of driver.

The limiting factor of the motor is the power dissipation, and not the current itself. To utilize the motor efficiently, power dissipation should be at the maximum allowed level.

Basic winding parameters and dimensioning

Under the conditions of a constant maximum allowable power dissipation P_R and a given winding space, i. e. a given copper volume, the only parameter that could be altered is the number of wire turns, or correspondingly, the wire diameter. See the fact box, "How are the winding parameters affected by the number of turns and the wire diameter?" on previous page.

Drive circuit schemes

The stepper motor driver circuit has two major tasks:

- To change the current and flux direction in the phase windings
- To drive a controllable amount of current through the windings, and enabling as short current rise and fall times as possible for good high speed performance.

Flux direction control

Stepping of the stepper motor requires a change of the flux direction, independently in each phase. The direction change is done by changing the current direction, and may be done in two different ways, using a bipolar or a unipolar drive. Figure 4 shows the two schemes. Only one of the two phases is shown as the two phases are identical.

How are the motor winding parameters affected by the number of turns and the wire diameter?

The cross-sectional area of the winding is A . The resistance of the winding as a function of the number of turns is found by the following idealized calculation:

$$R = \rho \cdot l / a \quad \text{where:}$$

$a = A / n$, the cross-sectional area of the wire;

wire length $l = 2\pi r \cdot n$; ρ is the resistivity of copper.

$$R = \rho \cdot 2\pi r \cdot n / (A / n) = 2\pi r \cdot \rho \cdot n^2 / A \approx n^2$$

The resistance is proportional to the square of the number of wire turns.

Inductance is calculated as (simplified):

$$L = 2\pi r^2 \cdot n^2 \approx n^2$$

The inductance is proportional to the square of the number of wire turns.

To calculate the current rating we use the condition of constant power dissipation:

$$P_R = R \cdot I_M^2$$

which leads to:

$$I_M = \sqrt{P_R / R} \approx \sqrt{P_R / n^2} \approx 1 / n$$

Current is inversely proportional to the number of turns.

Torque is proportional to the flux F , which is proportional to the number of ampere-turns in the winding:

$$T \approx \Phi \approx n \cdot I_M \approx n \cdot (1 / n) = \text{constant.}$$

Torque is constant at a constant power dissipation level, regardless of the number of turns.

Rated voltage is:

$$V_M = R \cdot I_M \approx n^2 \cdot (1 / n) \approx n$$

Rated voltage is proportional to the number of turns.

Finally, the electrical time constant is:

$$\tau_e = L / R \approx n^2 / n^2 = \text{constant}$$

The time constant is not affected by the number of turns.

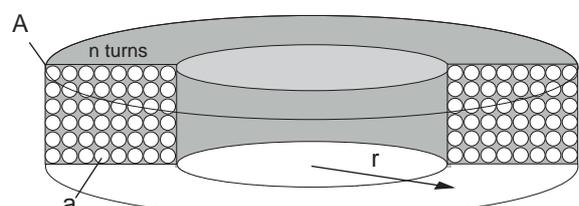

Bipolar drive

Bipolar drive refers to the principle where the current direction in one winding is changed by shifting the voltage polarity across the winding terminals. To change polarity a total of four switches are needed, forming an H-bridge.

The bipolar drive method requires one winding per phase. A two-phase motor will have two windings and accordingly four connecting leads.

Unipolar drive

The unipolar drive principle requires a winding with a center-tap, or two separate windings per phase. Flux direction is reversed by moving the current from one half of the winding to the other half. This method requires only two switches per phase. On the other hand, the unipolar drive utilizes only half the available copper volume of the winding. The power loss in the winding is therefore twice the loss of a bipolar drive at the same output power.

The unipolar, centertapped motor has three leads per phase, totally six leads for a two-phase motor. A motor having two separate windings per phase is usually referred to as an 8-lead motor. It may be connected both as a unipolar or a bipolar motor, see figure 5.

Current control

To control the torque as well as to limit the power dissipation in the winding resistance, the current must be controlled or limited. Furthermore, when half stepping a zero current level is needed, while microstepping requires a continuously variable current.

Two principles to limit the current are described here, the resistance limited drive and the chopper drive. Any of the methods may be realized as a bipolar or unipolar driver.

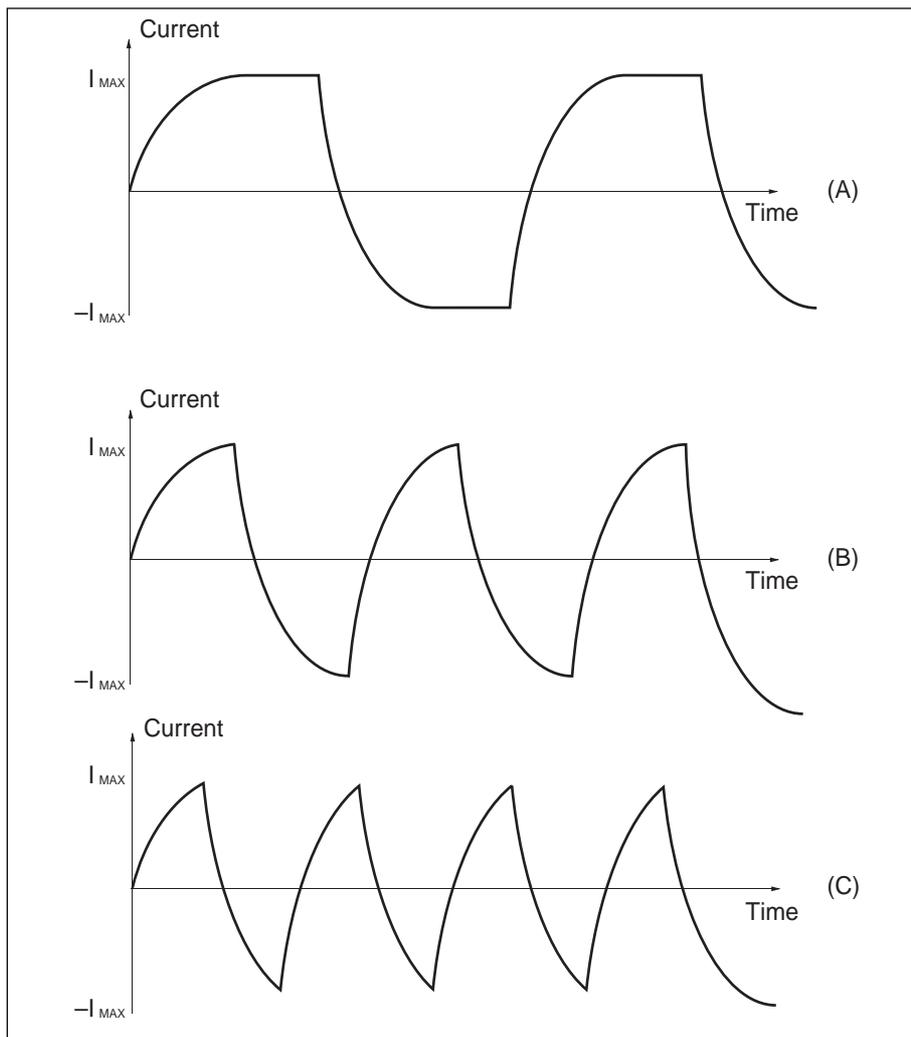

Figure 3. Current wave form in an inductive-resistive circuit.

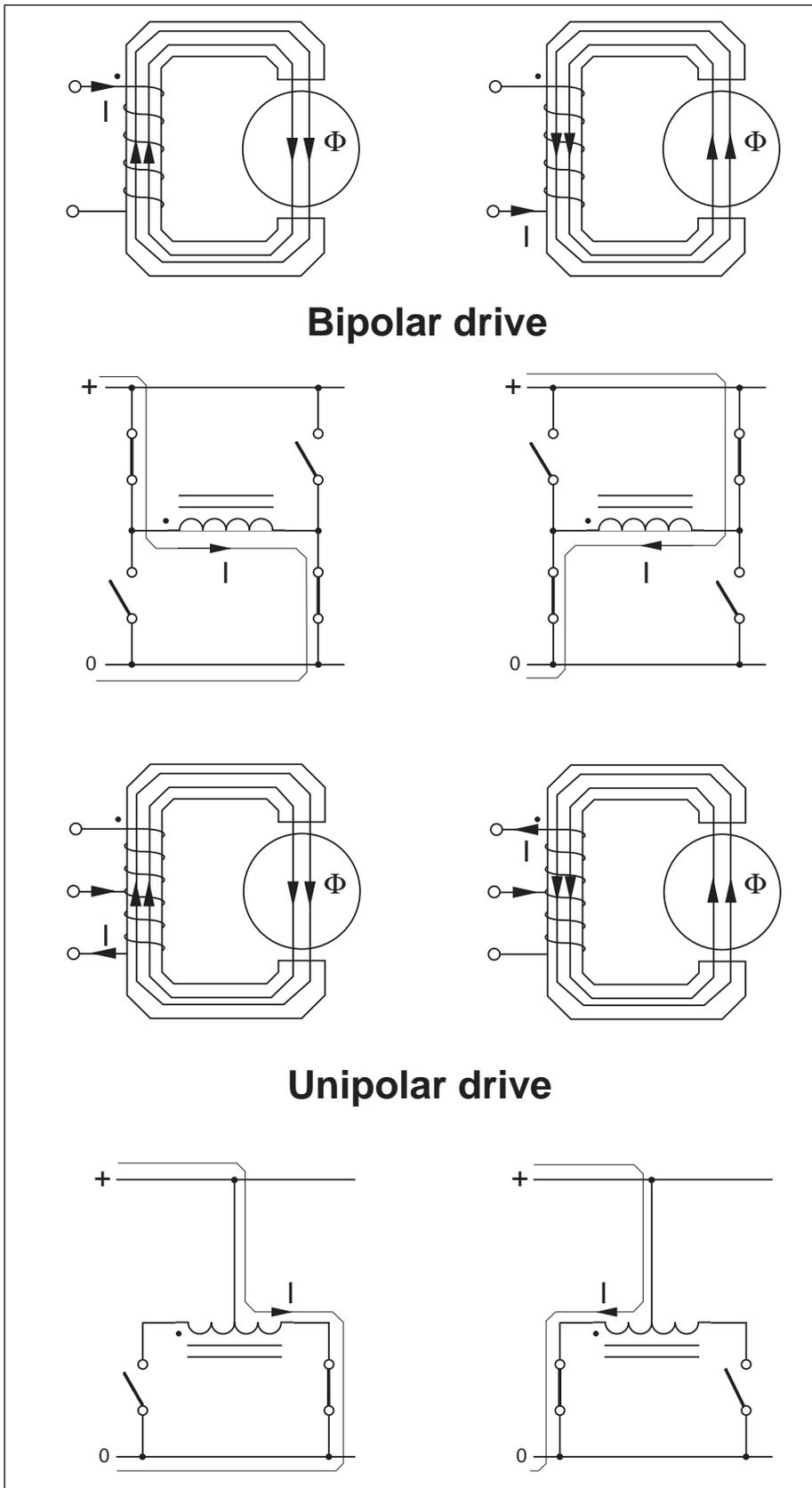

Figure 4. Bipolar and unipolar drive schemes to control the current and the flux direction in the phase winding.

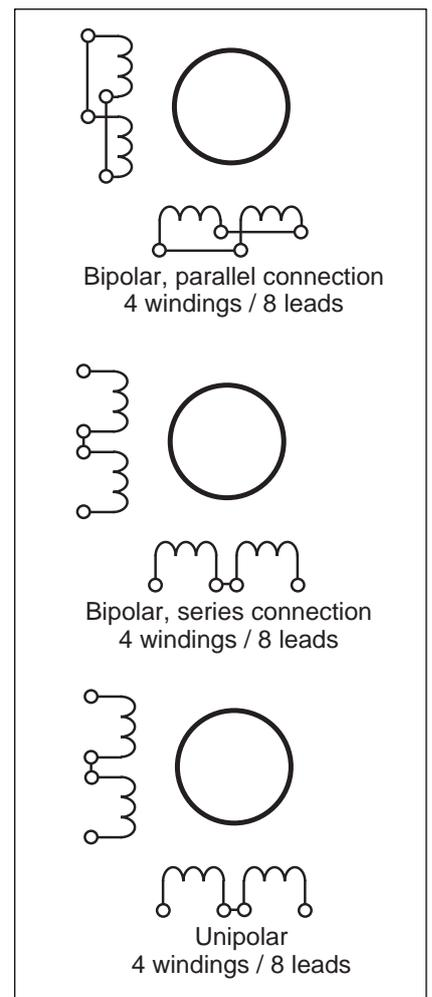

Figure 5. Different winding configurations for bipolar and unipolar drive using an 8-lead motor.

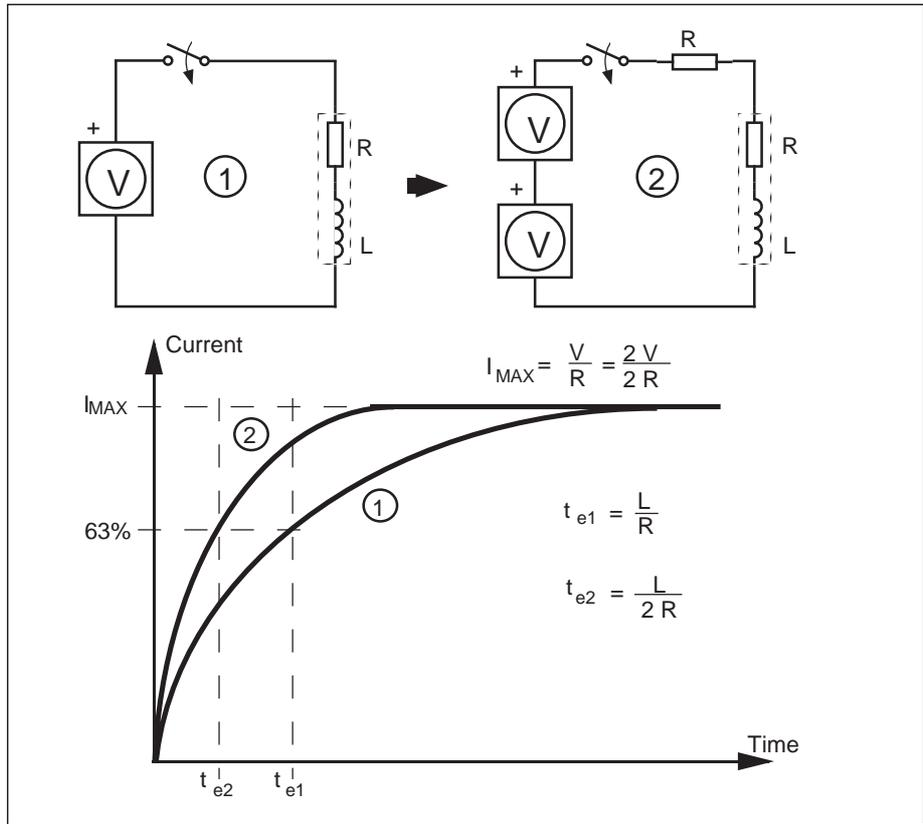

Figure 6. Resistance limitation of the current.

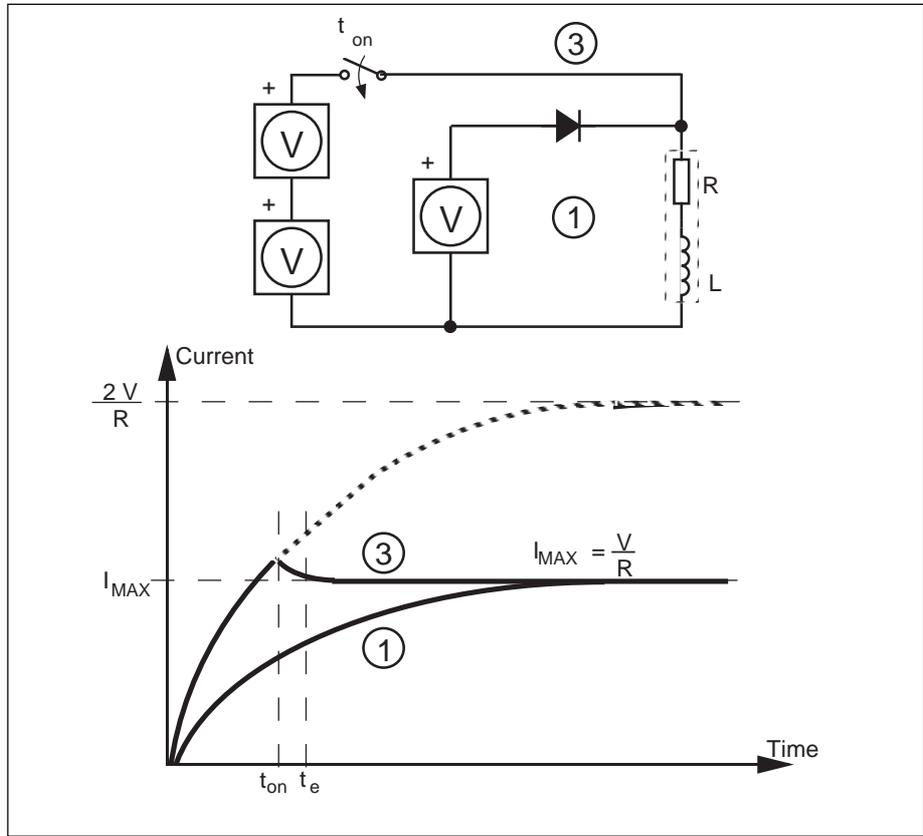

Figure 7. The bilevel drive.

Resistance limitation of the current (L/R drive)

In this basic method the current is limited by supply voltage and the resistance of the winding, and if necessary, an additional external resistance (dropping resistor):

$$I_M = V_{\text{supply}} / (R + R_{\text{ext}})$$

If the nominal motor voltage is the same as the supply voltage, R_{ext} is excluded.

For a given motor, high speed performance is increased by increasing the supply voltage. An increased supply voltage in the resistance limited drive must be accompanied by an additional resistor (R_{ext}) in series with the winding to limit the current to the previous level. The time constant:

$$t_e = L / (R + R_{\text{ext}})$$

decreases, which shortens the current rise time. See figure 6. The penalty using this method is the power loss in the additional external resistors. Usually several watts has to be dissipated - and supplied. Spacious power resistors, heat removal considerations and a space consuming power supply reduce costeffectiveness and limits L/R drive scheme to small motors, rated around 1- 2 Watts.

The bilevel L/R-drive

The bilevel L/R-drive provides a solution to the power waste using dropping resistors. In the beginning of the current build-up period, the winding is connected to a secondary high voltage supply. After a short time, when the current has reached its nominal level, the second level supply is disconnected. Figure 7 explains further. The disadvantage of bilevel drive is the need of a second level power supply. In some applications where 5 V and 12 V /24 V are available, it may be a cost effective solution, but, if not available, it is a costly method. It is possible to use voltage doubling techniques as well.

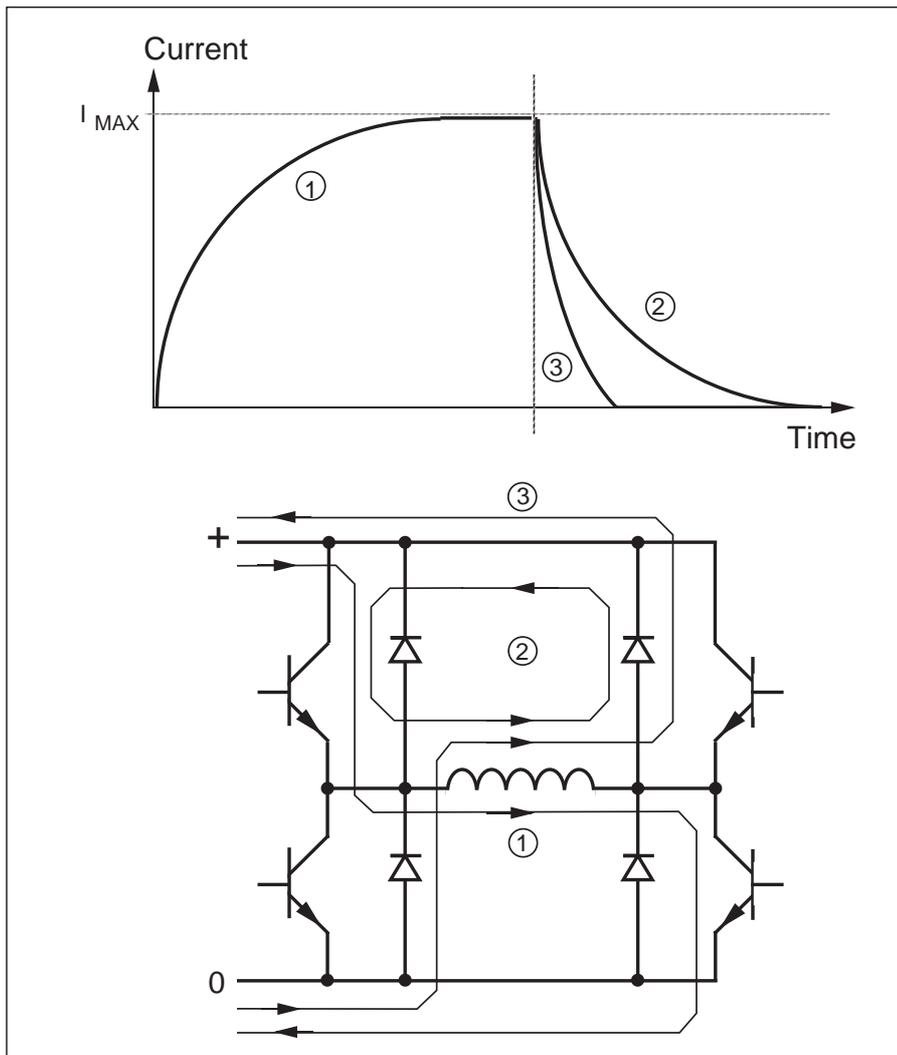

Figure 8. Current paths in the bipolar driver.

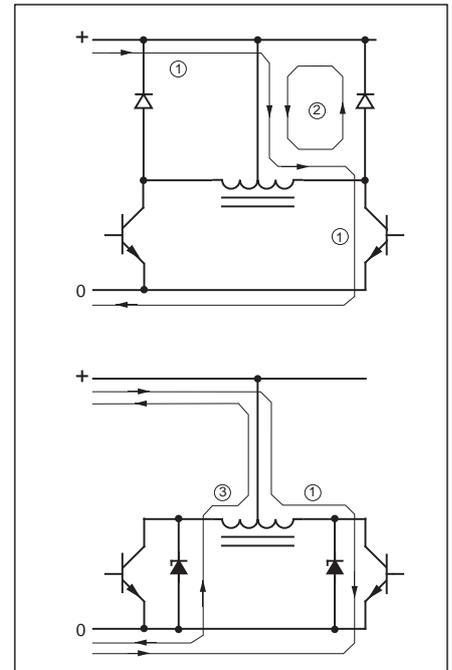

Figure 9. Current paths in the unipolar driver.

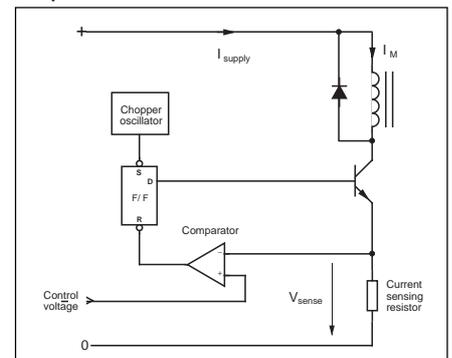

Figure 10. A simplified schematic shows the principle of constant current chopper regulation.

Current paths

Another very important consideration is current paths at turn-off and at phase shift. The inductive nature of the winding demands that a current path always exists. When using transistors as switches, diodes have to be added to enable current flow in both directions across the switch. For the bipolar driver four diodes, one for each switch, provide current paths according to figure 8. Note that there are two ways to turn the current off, either by turning all transistors off (path 3), or turn just one of the two conducting transistors off (path 2). The former gives a fast current decay as the energy stored in the winding inductance is discharged at a high voltage, V_{supply} . The latter gives a slow current decay as the counter voltage is only two diode voltage drops and the resistive voltage drop across the winding resistance. At phase shift the current will decay rapidly as both conducting transistors are turned off. For high speed halfstepping a rapid decay to zero in the half step position is important.

The unipolar driver is somewhat more complicated when it comes to current paths. The reason being the full coupling between the two halves of each phase winding, except for a small amount of leakage inductance. Figure 9 shows some possible schemes. Because of the coupling, large voltage transients—at least twice the supply voltage—occurs when switching on and off. The transistor switches must be rated at a much higher voltage than the supply voltage. The leakage inductance will also cause transients. Therefore the switching transistors has to be protected by snubber networks or zener diodes.

Chopper control

The chopper driver provides an optimal solution both to current control and fast current build-up and reversal. The basic idea is to use a supply voltage which is several times higher than the nominal voltage of the motor. The current rise rate, which initially is V/L , is thereby possible to increase substantially. The ratio V_M/V_{supply} is called the overdrive ratio. By controlling the duty cycle of the chopper, an average voltage and an average current equal to the nominal motor voltage and current are created. The chopper is usually configured for constant current regulation, see figures 10 - 12.

Constant current regulation is achieved by switching the output current to the windings. This is done by sensing the peak current through the winding via a current-sensing resistor, effectively connected in series with the motor winding. As the current increases, a voltage develops across the sensing resistor, which is fed back to the comparator. At the predetermined level, defined by the voltage at the reference input, the comparator resets the flip-flop, which turns off the output transistor. The current decreases until the clock oscillator triggers the flip-flops, which turns on the output transistor again, and the cycle is repeated.

The advantage of the constant current control is a precise control of the developed torque, regardless of power supply voltage variations. It also gives the shortest possible current build-up and reversal time. Power dissipation is minimized, as well as supply current. Supply current is not the same as the motor current in a copper drive. It is the motor current multiplied by the dutycycle, at standstill typically

$$I_{supply} = I_M \cdot (V_M/V_{supply})$$

Figure 12 shows an H-bridge configured as a constant current chopper. Depending on how the H-bridge is switched during the turn-off period, the current will either recirculate through one transistor and one diode (path 2), giving the slow current decay, or recirculate back through the power supply (path 3). The advantage of feeding the power back to the power supply is the fast current decay and the ability to quickly reduce to a lower current level. One example is when microstepping at a negative slope, which may be impossible to follow if the current decay rate is lower than the slope demands. The disadvantage with fast current decay is the increased current ripple, which can cause iron losses in the motor. Further discussion about the concept of fast/slow current decay can be found in the Half-stepping Techniques and Microstepping chapters.

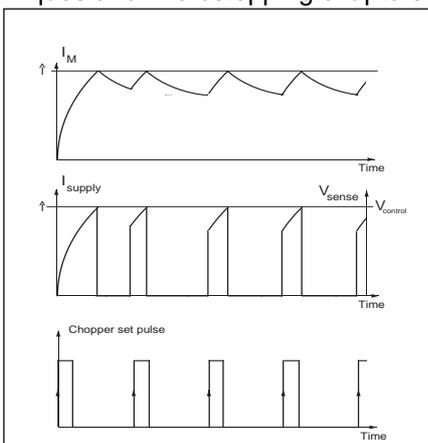

Figure 11. Current waveform in the basic chopper circuit.

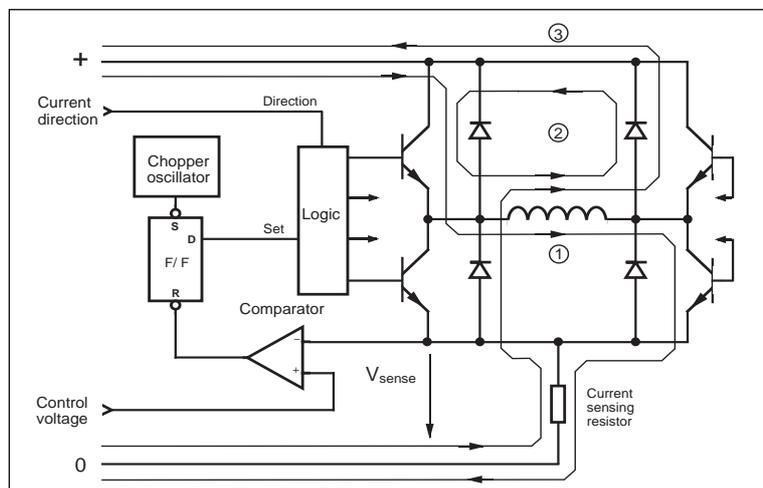

Figure 12. An H-bridge configured as a constant current chopper.

SUNSTAR 商斯达实业集团是集研发、生产、工程、销售、代理经销、技术咨询、信息服务等为一体的高科技企业，是专业高科技电子产品生产厂家，是具有 10 多年历史的专业电子元器件供应商，是中国最早和最大的仓储式连锁规模经营大型综合电子零部件代理分销商之一，是一家专业代理和分销世界各大品牌 IC 芯片和电子元器件的连锁经营综合性国际公司，专业经营进口、国产名厂名牌电子元件，型号、种类齐全。在香港、北京、深圳、上海、西安、成都等全国主要电子市场设有直属分公司和产品展示展销窗口门市部专卖店及代理分销商，已在全国范围内建成强大统一的供货和代理分销网络。我们专业代理经销、开发生产电子元器件、集成电路、传感器、微波光电元器件、工控机/DOC/DOM 电子盘、专用电路、单片机开发、MCU/DSP/ARM/FPGA 软件硬件、二极管、三极管、模块等，是您可靠的一站式现货配套供应商、方案提供商、部件功能模块开发配套商。商斯达实业公司拥有庞大的资料库，有数位毕业于著名高校——有中国电子工业摇篮之称的西安电子科技大学（西军电）并长期从事国防尖端科技研究的高级工程师为您精挑细选、量身订做各种高科技电子元器件，并解决各种技术问题。

微波光电部专业代理经销高频、微波、光纤、光电元器件、组件、部件、模块、整机；电磁兼容元器件、材料、设备；微波 CAD、EDA 软件、开发测试仿真工具；微波、光纤仪器仪表。欢迎国外高科技微波、光纤厂商将优秀产品介绍到中国、共同开拓市场。长期大量现货专业批发高频、微波、卫星、光纤、电视、CATV 器件：晶振、VCO、连接器、PIN 开关、变容二极管、开关二极管、低噪晶体管、功率电阻及电容、放大器、功率管、MMIC、混频器、耦合器、功分器、振荡器、合成器、衰减器、滤波器、隔离器、环行器、移相器、调制解调器；光电子元件和组件：红外发射管、红外接收管、光电开关、光敏管、发光二极管和发光二极管组件、半导体激光二极管和激光器组件、光电探测器和光接收组件、光发射接收模块、光纤激光器和光放大器、光调制器、光开关、DWDM 用光发射和接收器件、用户接入系统光收发器件与模块、光纤连接器、光纤跳线/尾纤、光衰减器、光纤适配器、光隔离器、光耦合器、光环行器、光复用器/转换器；无线收发芯片和模组、蓝牙芯片和模组。

更多产品请看本公司产品专用销售网站：

商斯达中国传感器科技信息网：<http://www.sensor-ic.com/>

商斯达工控安防网：<http://www.pc-ps.net/>

商斯达电子元器件网：<http://www.sunstare.com/>

商斯达微波光电产品网：[HTTP://www.rfoe.net/](http://www.rfoe.net/)

商斯达消费电子产品网：<http://www.icasic.com/>

商斯达实业科技产品网：<http://www.sunstars.cn/> 微波元器件销售热线：

地址：深圳市福田区福华路福庆街鸿图大厦 1602 室

电话：0755-82884100 83397033 83396822 83398585

传真：0755-83376182 (0) 13823648918 MSN: SUNS8888@hotmail.com

邮编：518033 E-mail:szss20@163.com QQ: 195847376

深圳赛格展销部：深圳华强北路赛格电子市场 2583 号 电话：0755-83665529 25059422

技术支持：0755-83394033 13501568376

欢迎索取免费详细资料、设计指南和光盘；产品凡多，未能尽录，欢迎来电查询。

北京分公司：北京海淀区知春路 132 号中发电子大厦 3097 号

TEL: 010-81159046 82615020 13501189838 FAX: 010-62543996

上海分公司：上海市北京东路 668 号上海赛格电子市场 D125 号

TEL: 021-28311762 56703037 13701955389 FAX: 021-56703037

西安分公司：西安高新开发区 20 所(中国电子科技集团导航技术研究所)

西安劳动南路 88 号电子商城二楼 D23 号

TEL: 029-81022619 13072977981 FAX:029-88789382