

### 1. FEATURE

NJM2625 is a controller and pre-driver for speed control 3-phase brushless DC motor. The device provides the proper sequencing of 3-phase drive output with external hall elements inputs.(120degree turn-on mode)

It is possible to control of 3-phase brushless DC motor by added external output buffers.

The device has totem-pole pre-drivers for external power MOS transistors and therefore can make the target output motor driver by using suitable power elements.

Further more the device has PWM control ,forward-reverse rotation and current limiting function.

### 2. Application Circuit

The application shown in below circuit is designed for an open loop motor speed control system that the upper power switch are P-Channel power MOSFET while the lower switches are N-Channel power MOSFET.

MOSFET drive (Upper:Pch ,Lower:Nch),Lower side PWM  
 Operating  $V^+$ :12V, supply  $V_m$ :24V

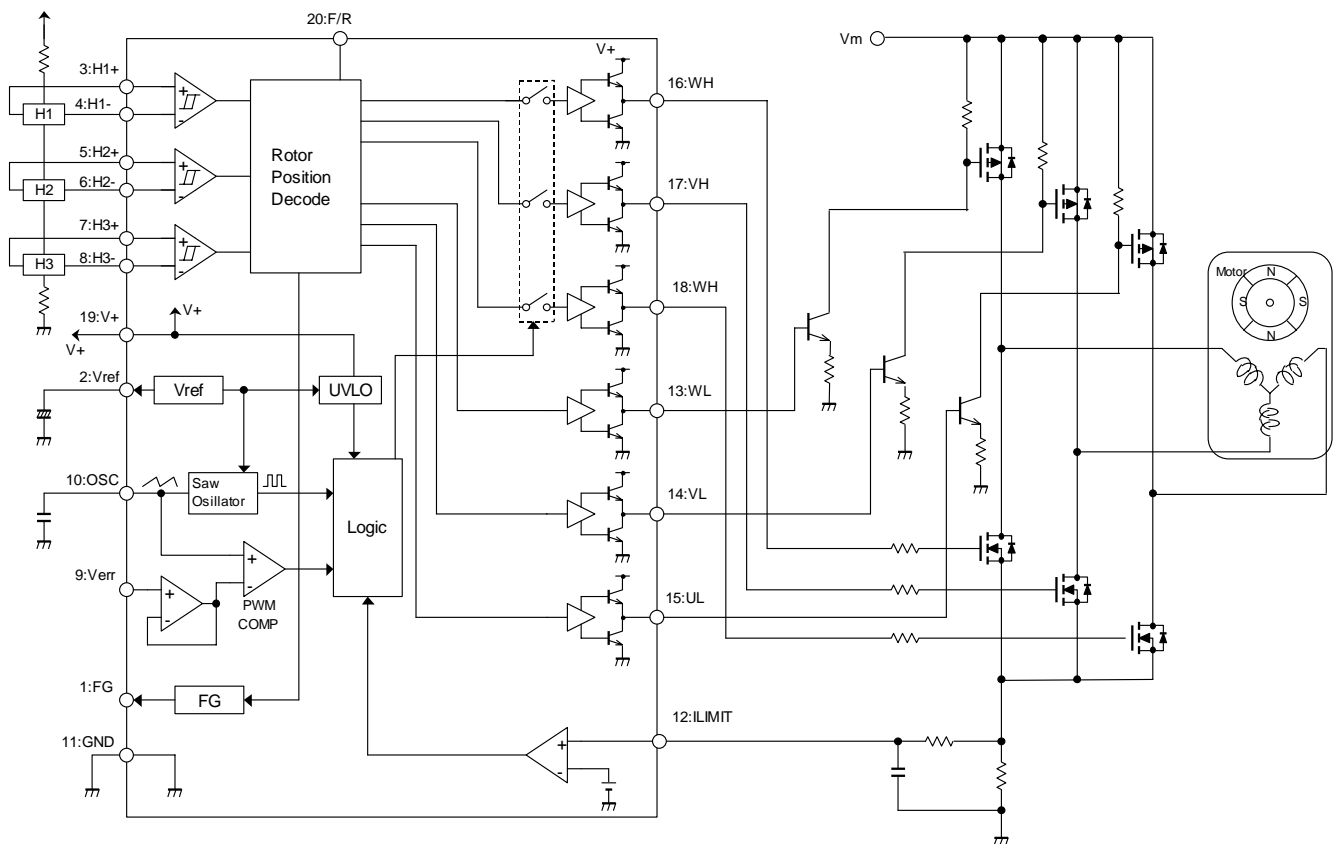

### 3. Terminal Functions

#### (3-1) WL, UL, VL

It consists of totem-pole pre-driver and control the upper P-Channel power MOSFET. The upper side GATE bias current is generated with connected Inverting transistor and resistor. Regarding design case at 4.5V about the GATE bias voltage of P-Channel power MOSFET.

$$I_{gate} = \frac{V_{oh} - V_{be}}{R_{bias}} = \frac{10 - 0.6}{470} = 20mA$$

$$V_{gs} = R_{gate} \times I_{gate} = 220 \times 0.02 = 4.5V$$

The values of R-bias and R-gate should be 470Ω, 220Ω.  
Here, it was referred to as Voh: 10V and Vbe:0.6V.

#### (3-2) WH, VH, UH

It consists of totem-pole pre-driver and control the lower N-Channel power MOSFET. It is possible to make motor speed control by PWM control. Series GATE resistor Rg will damp any high frequency oscillations caused by the MOSFET input capacitance and any series wiring induction in the gate-source circuit.

#### (3-3) H1+, H1-, H2+, H2-, H3+, H3-

It is the signal input terminal of the Hall device that controls ON-OFF of 3-phase MOSFET Bridge.

Positive input is defined as H+>H-, Negative is defined as H+<H-.

The Hall device output level should be over 50mVp-p since Hall Sensor Section has 30mVp-p Hysteresis Voltage. The amplitude of 120mV or more is recommended in consideration of a noise or temperature change.

Pre-driver outputs are all off if 3 set of Hall device inputs are simultaneously set to "H" or "L."

When you use not a Hall device but Digital output like Hall IC as motor phase sensor, please receive in a circuit like appending figure (4-1) in consideration of Input Common mode Voltage range of a Hall Sensor Section.

#### (4-4) FG

It is the pulse output terminal proportional to the number of rotations of a motor. It becomes the synthetic waveform of a Hall device signal.

#### (4-5) F/R

It is the motor rotation direction input terminal and is controllable by setting the terminal to "H" or "L." A rotation direction change must be made after motor stopped completely.

In such case, switching elements will generate a vertical arm short circuit and it may cause destruction of the switching devices.

However, if PWM is closed before and after a rotation direction change (Verr<0.35V), a rotation direction can be performed safely.

The relation between F/R input and the motor rotation direction is as follows.

F/R Input and Motor Rotation	
F/R	Direction
L	U⇒V⇒W
H	U⇒W⇒V

# 3-Phase DC Brushless Motor Pre-Drivers

## Technical Information

**NJM2625**

The relation between Hall inputs and commutation logic outputs is as follows.

Commutation logic truth table												
Hall Inputs						Outputs						
F/R=L			F/R=H			UH	VH	WH	UL	VL	WL	FG
H1	H2	H3	H1	H2	H3							
H	L	H	L	H	L	L	H	L	H	L	L	H
H	L	L	L	H	H	L	L	H	H	L	L	L
H	H	L	L	L	H	L	L	H	L	H	L	H
L	H	L	H	L	H	H	L	L	L	H	L	L
L	H	H	H	L	L	H	L	L	L	L	H	H
L	L	H	H	H	L	H	L	L	L	L	H	L

The information of the timing chart is shown in attached (4-2)

#### (4-6) I<sub>LIMIT</sub>

It is the motor over-current detection terminal. The motor current is converted to a voltage by inserting a ground-referenced sense resistor R<sub>s</sub> in series with the three lower MOSFETs. The voltage developed across the sense resistor is monitored by I<sub>LIMIT</sub> terminal, and compared to the internal Sense Voltage(V<sub>th</sub>).

If the current sense is exceeded, the comparator sets the over-current latch and terminates the PWM output.

Over-current detection is reset for every cycle of the internal Oscillator.

The value for over-current detection is:

$$I = \frac{V_{th}}{R_s}$$

When an over-current detection function is not well detected by the noise etc., the addition of the RC filter will eliminate current-limit instability by the leading edges spike on the current waveform.

#### (4-7) V<sub>ref</sub>

It is the output terminal of internal reference voltage. This terminal please inserts capacitor between GND for stabilization. (We recommend capacitor value is 1μF.)

#### (4-8) V<sub>err</sub>

It is the motor speed control terminal. Input voltage is compared with internal triangular wave voltage, and PWM operation is carried out.

The use of PWM provides an energy efficient method of controlling the motor speed by varying the average voltage applied to each motor winding.

Please input the voltage of 0 V-V<sub>ref</sub>.

When the motor speed control stabilized more is required, Closed Loop Control using FG signal etc. is performed.

#### (4-9) OSC

By connecting a capacitor to this terminal, the internal Oscillation frequency is decided.

Frequency is set to about 25kHz when capacitor value is 1000pF. If frequency is low, the switching sound from a motor will occur, and if high, the switching loss of a Power element will increase.

We recommend selection with a frequency of 20 to 30kHz.

### 4. Appendix

#### (4-1) The example of Hall IC interface

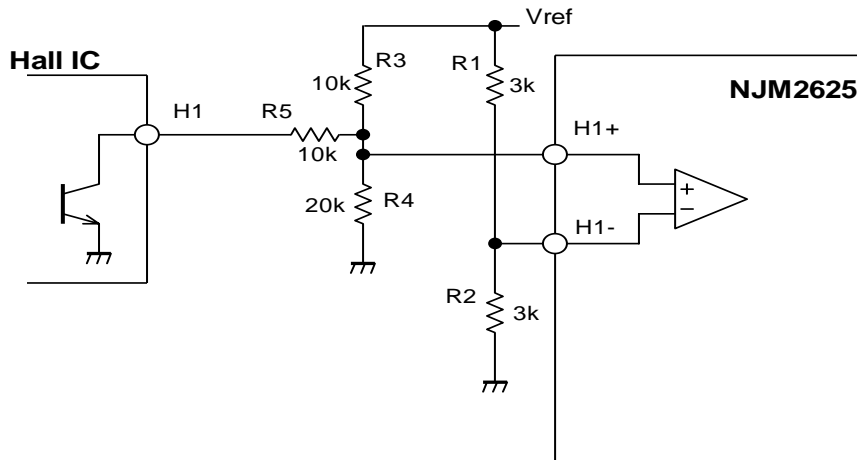

$R1=R2$

H1=High: R3 and R4 are set up so that voltage of H1+ terminal is smaller than  $V_{cc}-1.5V$ .

H1=Low: R3 and R4 are set up so that voltage of H1+ terminal is larger than 1.5V.

#### (4-2) The timing chart of Hall input and pre-driver output

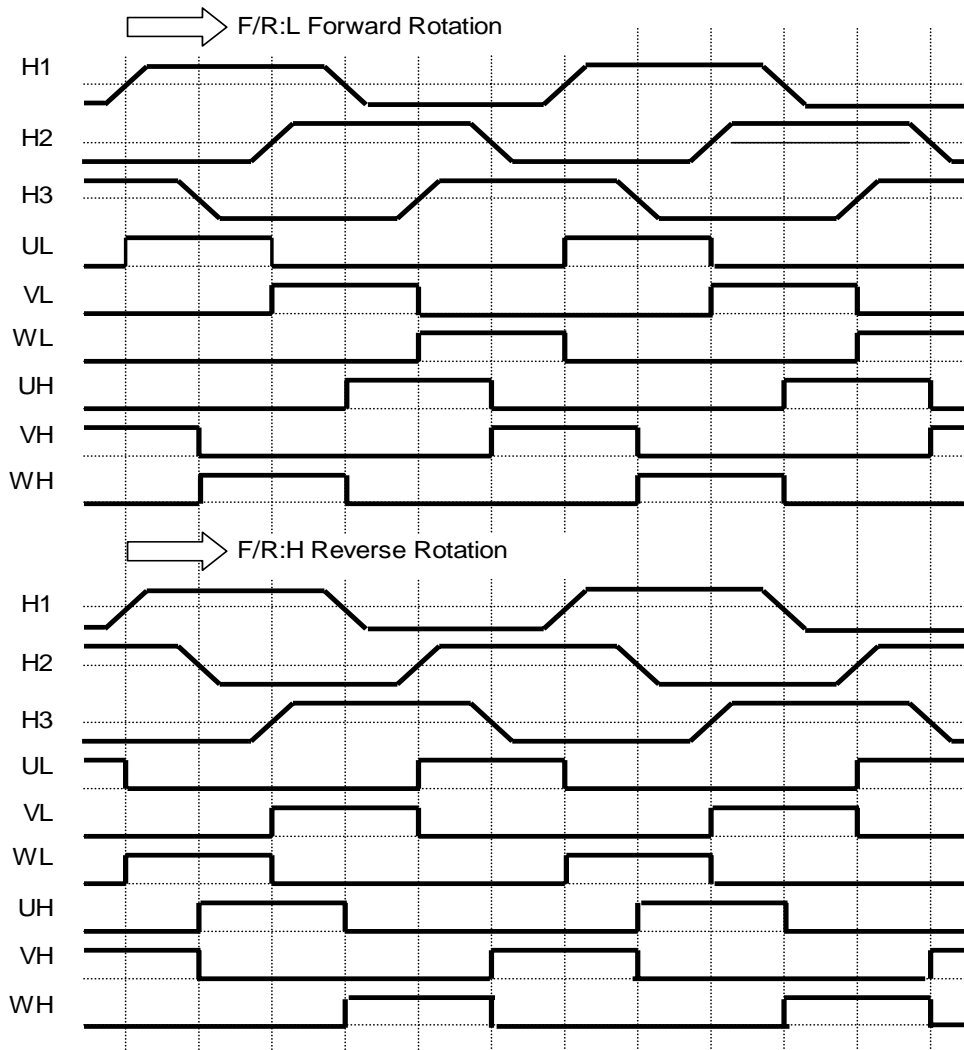

# 3-Phase DC Brushless Motor Pre-Drivers

## Technical Information

**NJM2625**

### (4-3) The TTL logic level conversion circuit of FG output

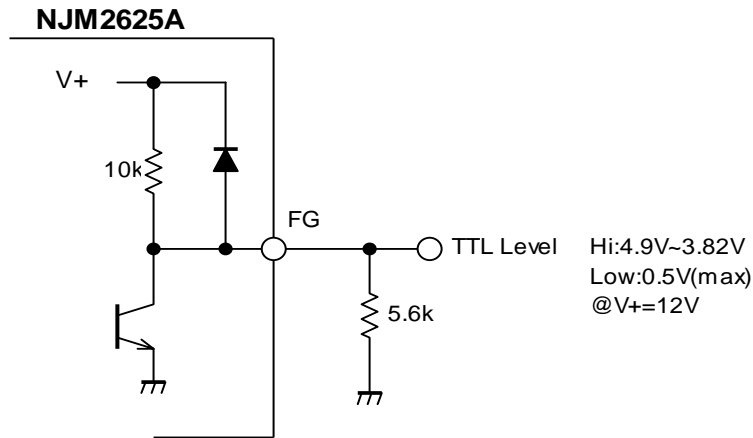

### (4-4) Closed Loop speed control circuit

Speed control circuit is shown as following figure. This circuit consists of input buffer, Level shifter and Speed control amplifier. Motor speed can be changed by "speed set" VR. VR1 is trimmer for final stage gain for stability. NJM13403 is quad single supply general-purpose operational amplifier. The typical values of the other parts are shown in figure.

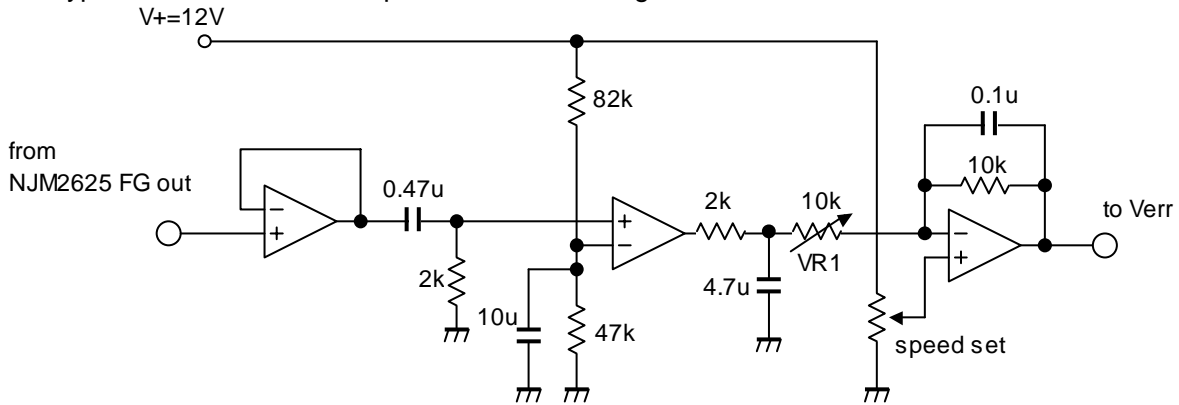

Opamp: NJM13403

The speed control circuit and the interface of NJM2625 are as follows.

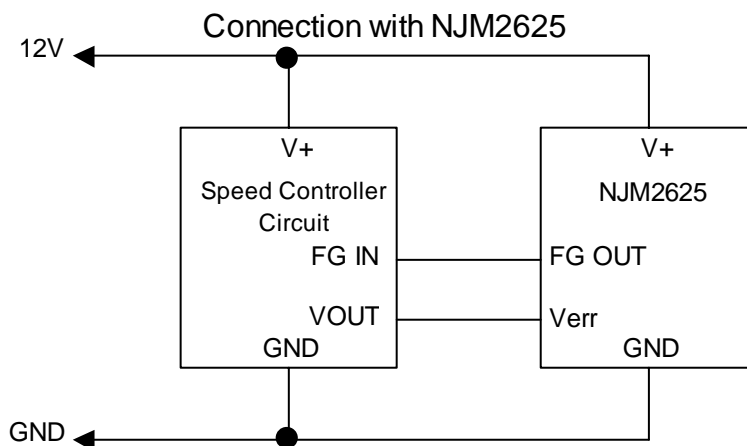

\*For other pins' connection, see product catalog.