

DATA SHEET

UCB1100

Advanced modem/audio analog front-end

Preliminary specification
Supersedes data of 1996 Apr 09
Version 1.2

1998 May 08

Advanced modem/audio analog front-end

UCB1100

Version 1.2

GENERAL DESCRIPTION

The UCB1100 is a single chip, integrated mixed signal audio and telecom codec. The single channel audio codec is designed for direct connection of a microphone and speaker. The built-in telecom codec can directly be connected to a DAA and supports high speed modem protocols. The incorporated 10 bit analogue to digital converter and the touch screen interface provides complete control and readout of a connected 4 wire resistive touch screen. The 10 additional general purpose I/O pins provides programmable inputs and/or outputs to the system.

The UCB1100 has a serial interface bus (SIB) intended to communicate to the system controller. Both the codec input and output data and the control register data is multiplexed on this SIB interface.

APPLICATIONS

- Personal Intelligent Communicators
- Personal Digital Assistants (PDA)
- Screen phones
- Smart Phone and smart Fax
- Intelligent Communicators

KEY FEATURES

- 48-pin LQFP (SOT313-2) small body SMD package and low external component count result in minimal PCB space requirement.
- A 12-bit sigma delta audio codec with programmable sample rate, input and output voltage levels, capable of connecting directly to speaker and microphone, including digitally controlled mute, loopback and clip detection functions
- A 14-bit sigma delta telecom codec with programmable sample rate, including digitally controlled input voltage level, mute, loopback and clip detection functions. The telecom codec is intended for direct connection to a DAA (digital access arrangement) and includes a built-in sidetone suppression circuit.
- A complete 4 wire resistive touch screen interface circuit supporting position, pressure and plate resistance measurements.
- A 10-bit successive approximation ADC with internal track and hold circuit and analogue multiplier for touch screen readout and monitoring of four external high voltage (7.5V) analogue voltages.
- A high speed, 4 wire serial interface data bus (SIB) for communication to system controller.
- A 3.3V supply voltage and built in power saving modes make the UCB1100 optimal for portable and battery powered applications.

TABLE OF CONTENTS

GENERAL DESCRIPTION	2
APPLICATIONS	2
KEY FEATURES	2
TABLE OF CONTENTS	2
1.0 FUNCTIONAL BLOCK DIAGRAM	3
2.0 ORDERING INFORMATION	4
3.0 ABSOLUTE MAXIMUM RATINGS	4
4.0 DC ELECTRICAL CHARACTERISTICS	5
5.0 PINOUT	6
5.1 PINLIST	7
6.0 FUNCTIONAL DESCRIPTION	8
6.1 AUDIO CODEC	8
6.1.1 AUDIO INPUT SPECIFICATIONS	10
6.1.2 AUDIO OUTPUT SPECIFICATIONS	11
6.2 TELECOM CODEC	12
6.2.1 TELECOM INPUT SPECIFICATIONS	14
6.2.2 TELECOM OUTPUT SPECIFICATIONS	15
6.3 TOUCH SCREEN MEASUREMENT MODES	16
6.3.1 POSITION MEASUREMENT	16
6.3.2 PRESSURE MEASUREMENT	16
6.3.3 PLATE RESISTANCE MEASUREMENT	16
6.4 TOUCH SCREEN INTERFACE	17
6.4.1 TOUCH SCREEN SPECIFICATIONS	18
6.5 10 BIT ADC	19
6.5.1 SPECIFICATION OVERVIEW	21
6.6 ON CHIP REFERENCE CIRCUIT	21
6.6.1 SPECIFICATION OVERVIEW	21
6.7 SERIAL INTERFACE BUS	22
6.7.1 SIB DATA FORMAT	23
6.7.2 CODEC DATA TRANSFER	24
6.7.3 CONTROL REGISTER DATA TRANSFER	26
6.7.4 AC ELECTRICAL CHARACTERISTICS	27
6.8 GENERAL PURPOSE I/Os	27
6.9 INTERRUPT GENERATION	27
6.10 RESET CIRCUITRY	28
7.0 MISCELLANEOUS	29
7.1 POWER ROUTING STRATEGY	29
8.0 CONTROL REGISTER OVERVIEW	30
9.0 PACKAGE OUTLINES	34
9.1 PACKAGE OUTLINE LQFP48	34
10.0 DEFINITIONS	36

Advanced modem/audio analog front-end

UCB1100

1.0 FUNCTIONAL BLOCK DIAGRAM

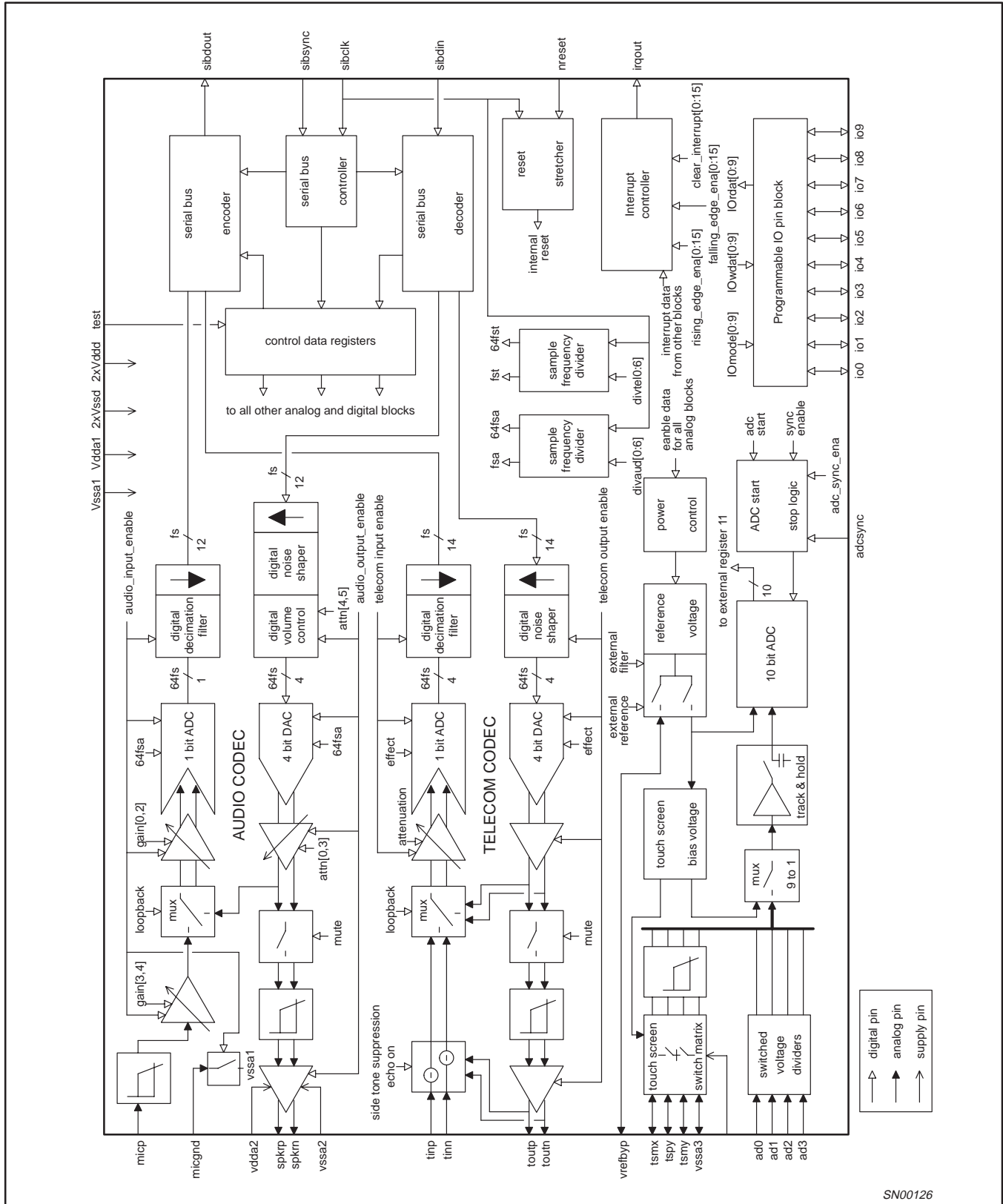

SN00126

Figure 1. Block Diagram of the UCB1100

Advanced modem/audio analog front-end

UCB1100

2.0 ORDERING INFORMATION

DESCRIPTION	ORDERING CODE	PACKAGE DRAWING
Plastic low profile quad flat package; 48 leads	UCB1100LP/X3	SOT313-2

3.0 ABSOLUTE MAXIMUM RATINGS

SYMBOL	PARAMETER	MIN	MAX	UNIT
V_{DDMAX}	Supply voltage	-0.5	5.0	V
V_{IMAX}	DC input voltage, except AD0-3 inputs	-0.5	$V_{DD}+0.5$	V
V_{ADMAX}	DC input voltage AD0-3 inputs	-0.5	8.5	V
V_{OMAX}	DC output voltage	-0.5	$V_{DD}+0.5$	V
I_{IKMAX}	DC diode input current, all inputs		10	mA
I_{OKMAX}	DC diode output current		10	mA
I_{OLMAX}	Continuous output current, digital outputs		4	mA
T_{stg}	Storage temperature	-55	150	°C

NOTES:

1. Stresses above those listed under Absolute Maximum Ratings may cause permanent damage to the device. This is a stress rating only and functional operation of the device at these or any conditions other than those described in the Absolute Maximum Rating section of this specification is not implied.
2. This product includes circuitry specially designed for the protection of its internal devices from damaging effects of excessive static charge. Nonetheless, it is suggested that conventional precautions be taken to avoid submitting the UCB1100 to conditions exceeding the maximum ratings.
3. Parameters are valid over the operating ambient temperature unless otherwise specified. All voltages are with respect to the V_{SSD} pin, unless otherwise noted.

Advanced modem/audio analog front-end

UCB1100

4.0 DC ELECTRICAL CHARACTERISTICS

$T_{amb} = 0^{\circ}\text{C}$ to 70°C , $V_{SSD} = V_{SSA1} = V_{SSA2} = V_{SSA3} = 0\text{V}$, $sibclk = 10\text{MHz}$, $audio_divisor = 12$, $telecom_divisor = 40$.
Voltage with respect to the V_{SSD} pin, unless otherwise specified.

SYMBOL	PARAMETER	NOTES	LIMITS			UNIT
			MIN	TYP	MAX	
V_{DDD}	digital supply voltage		3.0	3.3	3.6	V
V_{DDA1}	analogue supply voltage (excl. speaker driver)		3.0	3.3	3.6	V
V_{DDA2}	analogue supply voltage (speaker driver only)		3.0	3.3	3.6	V
V_{SSA2}	analogue ground voltage wrt. V_{SSD}		-0.4	0	0.4	V
V_{SSA3}	analogue ground voltage wrt V_{SSD}		-0.4	0	0.4	V
I_{DDD}	digital supply current, full functionality only audio codec activated only telecom codec activated only touch screen activated only adc activated no functions activated, $sibclk$ stopped	Note 1		19 17 19 15 15	10	mA mA mA mA mA μA
I_{DDA1}	analogue supply current, full functionality only audio codec activated only telecom codec activated only touch screen activated only adc activated no analogue functions activated	Note 1, Note 2		3.8 1.5 1.7 0.4 0.5 <10		mA mA mA mA mA μA
I_{DDA2}	total speaker driver supply current full functionality only audio codec activated only telecom codec activated only touch screen activated only adc activated no analogue functions activated	Note 1, Note 2		0.2 0.2	10 10 10 10	mA mA μA μA μA μA
V_{TSCB}	touch screen bias voltage			1.8		V
I_{TSCB}	maximum touch screen bias current		10			mA
V_{ADFS}	full scale voltage ad0–ad3 inputs			7.5		V
V_{TSFS}	full scale input touch screen inputs			7.5		V
V_{IL}	input low voltage		-0.5		$0.3 \cdot V_{DDD}$	V
V_{IH}	input high voltage		$0.7 \cdot V_{DDD}$		$V_{DDD} + 0.5$	V
V_{OL}	output low voltage	$I_{OL} = 2\text{mA}$			$0.2 \cdot V_{DDD}$	V
V_{OH}	output high voltage	$I_{OH} = 2\text{mA}$	$0.8 \cdot V_{DDD}$			V
f_{SIBCLK}	clock frequency		0	10	15	MHz
T_{amb}	Operating Ambient Temperature		0		70	$^{\circ}\text{C}$

NOTES:

1. Indicative value only. Value will be frozen following silicon measurements.
2. Excluding connected touch screen and speaker load currents.

Advanced modem/audio analog front-end

UCB1100

5.0 PINOUT

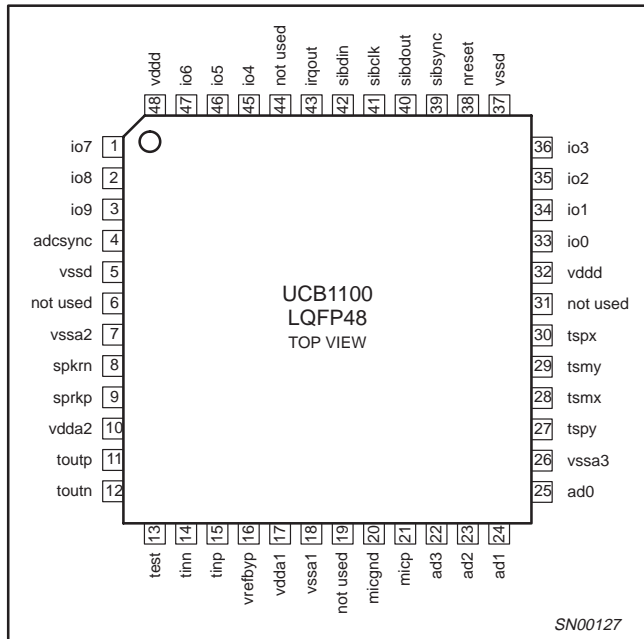

Figure 2. LQFP48 (SOT313-2)

Advanced modem/audio analog front-end

UCB1100

5.1 Pinlist

SYMBOL	PINNING	PIN TYPE	RESET STATE	DESCRIPTION	NOTE
	LQFP48				
vddd	32, 48	supply		digital supply	
vssd	5, 37	ground		digital ground	1
vdda1	17	supply		analogue supply	
vssa1	18	ground		analogue ground	1
vdda2	10	supply		analogue speaker driver supply	
vssa2	7	ground		analogue speaker driver ground	
vssa3	26	ground		touch screen switch matrix ground	
sibclk	41	CMOS input		SIB serial interface master clock	
sibdin	42	CMOS input		SIB data input	
sibdout	40	CMOS output	'0' / Hi-Z	SIB data output	2
sibsync	39	CMOS input		SIB synchronization	
irqout	43	CMOS output active-High	'0'	interrupt output	
micp	21	analogue input	Hi-Z	microphone signal input	
micgnd	20	analogue input	Hi-Z	microphone ground switch input	
sprkp	9	analogue output	Hi-Z	positive speaker output	3
spkrn	8	analogue output	Hi-Z	negative speaker output	3
tinp	15	analogue input	Hi-Z	positive telecom codec input	3
tinn	14	analogue input	Hi-Z	negative telecom codec input	3
toup	11	analogue output	Hi-Z	positive telecom codec output	3
toutn	12	analogue output	Hi-Z	negative telecom codec output	3
ad0–3	25–22	analogue input	Hi-Z	analogue high voltage inputs	
tspx	30	analogue IO	Hi-Z	positive X-plate touch screen	
tsmx	28	analogue IO	Hi-Z	negative X-plate touch screen	
tspy	27	analogue IO	Hi-Z	positive Y-plate touch screen	
tsmy	29	analogue IO	Hi-Z	negative Y-plate touch screen	
adcsync	4	digital input		adc synchronization pulse input	
vrefbyp	16	analogue IO	Hi-Z	external reference voltage input, external filter connection	
io0–9	33–36, 45–47, 1–3	CMOS IO	input	general purpose IO pins	
nreset	38	CMOS input active-Low		asynchronous reset input	
test	13	CMOS input	'0'	test mode protection	4
not used	6, 19, 31, 44			not connected pins	

NOTES:

1. The vssd and vssa1 pins are connected to each other within the UCB1100.
2. The first 64 bits of the sib frame will be '0', the remaining bits in the sib frame will be Hi-Z.
3. The spkrp/spkrn, tinp/tiln and toup/toutn are differential pairs.
4. The test pin contains a internal pull down. This pin should be connected to vssd in normal mode of the UCB1100.

Advanced modem/audio analog front-end

UCB1100

6.0 FUNCTIONAL DESCRIPTION

The UCB1100 consists of several analogue and digital sub circuits which can be programmed via the Serial Interface Bus (SIB). This enables the user to set the UCB1100 functionality according actual application requirements.

6.1 Audio codec

The audio codec contains an input channel, built up from a 64 times oversampling sigma delta analogue to digital converter (ADC) with digital decimation filters and a programmable gain microphone preamp. The output path consists of a digital up sample filter, a 64 time oversampling 4 bit digital to analogue converter (DAC) circuit followed by a speaker driver, capable of driving directly a low impedance bridge tied (BTL) speaker. The output path features digitally programmable attenuation and a mute function. The audio codec also incorporates a loopback mode, in which codec output path and the input path are connected in series.

The audio sample rate is derived from the SIB interface clock pin (SIBclk) and is programmable through the SIB interface. The audio sample rate is given by the following equation:

$$Fsa = \frac{(2 * F_{sibclk})}{(64 * audio_divisor)} \quad (5 < audio_divisor < 128)$$

For example, a serial clock of 10 MHz, with a divisor of 14, results in an audio sample rate of 22.321kHz. Both the rising and the falling edges of the sibclk are used in case an odd audio_divisor is set. Thus a 50% duty cycle of the sibclk signal is mandatory to obtain time equidistant sampling with odd divisors.

The frequency response of the audio codec depends mainly on the selected sample rate, since the bandwidth is limited in the down and up sampling filters. These digital filters both contain several FIR and IIR low pass filters and a DC removal filter (high pass filter). A 1st order analogue anti aliasing filter is implemented at the input of the microphone input to prevent aliasing in the adc path. A 3rd order smoothing filter is implemented between dac and speaker driver stage to reduce the spurious frequencies at the speaker outputs.

The audio codec input (=ADC) and output (= DAC) paths can be enabled individually by setting the audio_adc and/or audio_dac bits in the audio control register B. These enable bits operate both on the associated analogue and digital functions, for optimal power control of both the analogue and the digital parts.

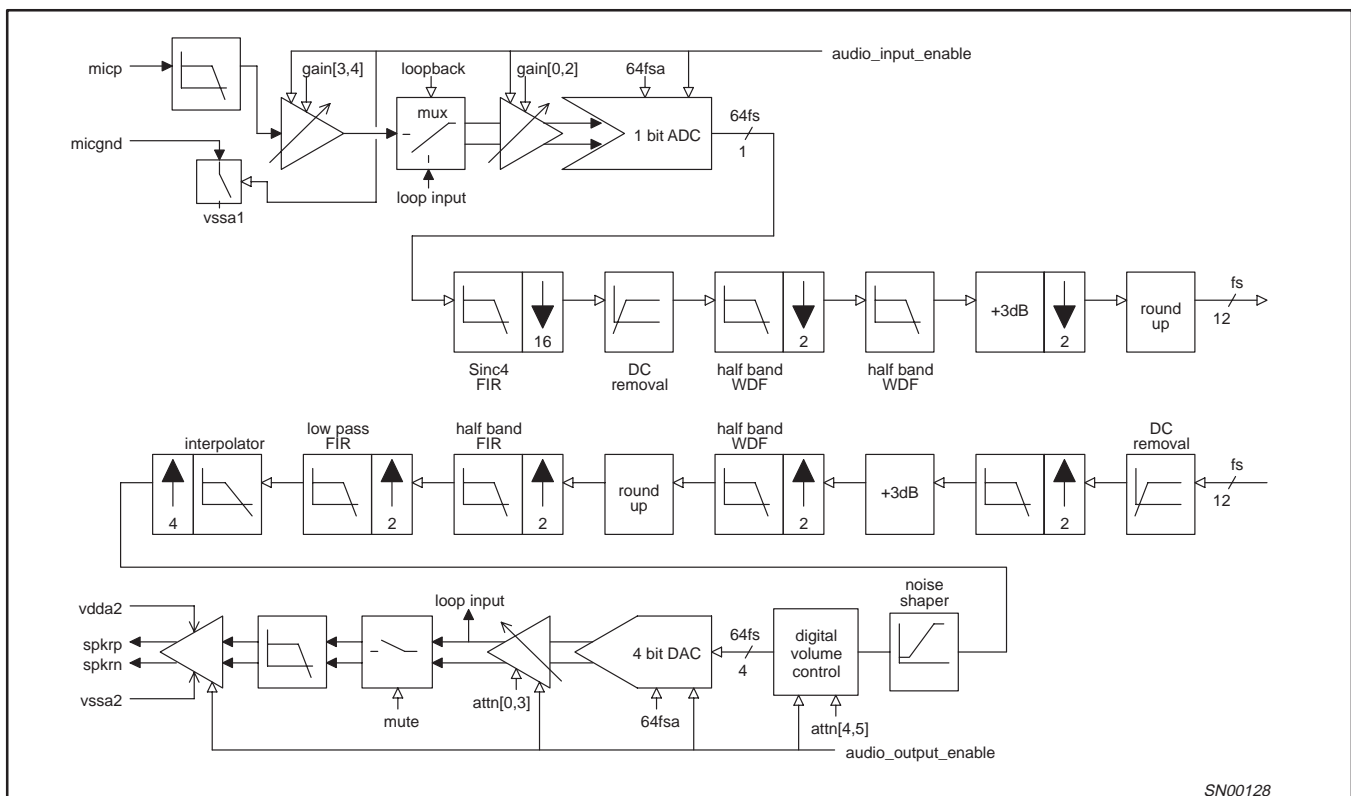

Figure 3. Detailed Block Diagram Audio codec

Advanced modem/audio analog front-end

UCB1100

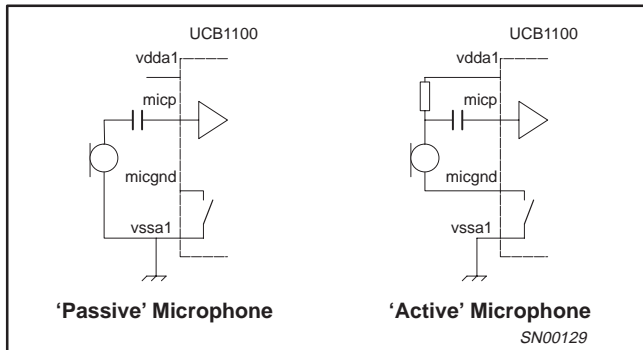

Figure 4. Possible Microphone Connections

The UCB1100 audio codec input path accepts microphone signals directly, only a DC blocking capacitor is needed, since the micp input is biased around 1.4V. The 'ground' side of the microphone is either connected to the analogue ground (vssa1) or to the micgnd pin of the UCB1100. The latter will decrease the current consumption of active microphones, since the micgnd pin is made Hi-Z when the audio codec input path is disabled.

The full scale input voltage of the audio input path is programmable in 1.5dB steps by setting the appropriate data in the *audio-input-gain* bits in the audio control register A.

A clip detection circuit will inform the user whenever the input voltage exceeds the maximum input voltage. In that case the *clip detect status* bit in audio control register B is set. An interrupt is generated on the irqout pin of the UCB1100 whenever the *enable audio clip detect rising interrupt* or the *enable audio detect falling edge interrupt* bit is set in the rising edge interrupt enable or falling edge interrupt control register B is set.

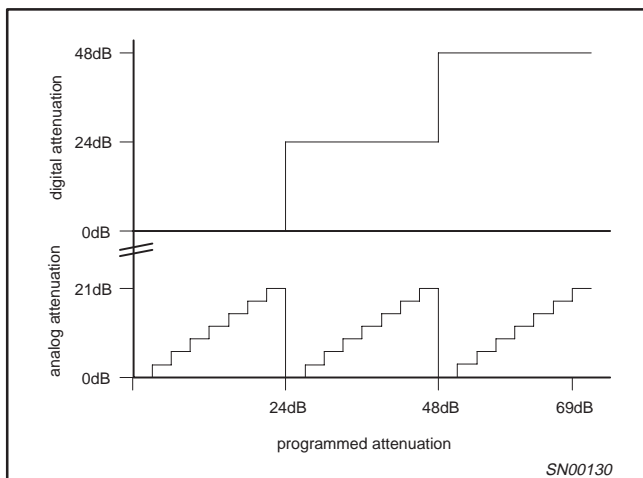

Figure 5. Analogue and Digital Attenuation Settings Audio Output Path

The output level can be attenuated in 3dB steps down to -69dB. The 8 highest attenuation steps are implemented in the analogue circuitry, while the two 24dB steps are implemented in the digital domain. This preserves the 'audio quality' of the output signal at lowest attenuation settings. The speaker driver is muted when the *audio-mute* bit in the audio control register B is set. The speaker driver will remain activated in that case, however no signal is produced by the speaker driver circuitry.

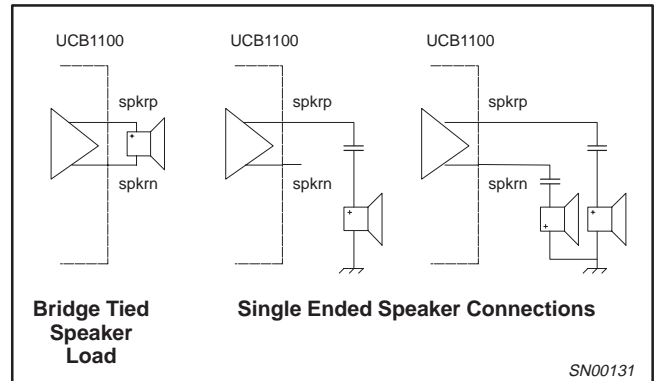

Figure 6. Possible Speaker Connections

The speaker driver is designed to directly drive a bridge tied load (BTL). This yields the highest output power and it does not require external DC blocking capacitors. The speaker driver also accepts single ended connection of a speaker, in which case the maximum output power is reduced to a quarter of the BTL situation. Consequently this way of connecting the speaker to the speaker driver reduces the power consumption of the speaker driver in the UCB1100 by a factor of 2. Figure 6 shows possible ways to connect a speaker to the UCB1100.

The audio input and output path are activated independently; the input path is enabled when the *audio-input-enable* bit is set, the output path is enabled when the *audio-output-enable* bit is set in the audio control register B. This provides the user the means to reduce the current consumption of the UCB1100 if one part of the audio codec is not used in the application.

The audio codec has a loopback mode for system test purposes, which is activated when the *audio_loopback_enable* bit in the audio control register B is set. This is an analogue loopback which internally connects the output of the audio output path to the input of the audio input path, (see Figure 3). In this mode the normal microphone input is ignored, but the speaker driver can be operated normally.

Advanced modem/audio analog front-end

UCB1100

6.1.1 Audio Input Specifications

SYMBOL	PARAMETER	CONDITIONS	LIMITS			UNIT
			MIN	TYP	MAX	
F _{SA}	audio sample frequency				26	kHz
V _{INAM}	full scale input voltage	0 dB gain setting		0.28		V _{pp}
V _{MICP}	DC bias voltage micp input	audio input path enabled		1.4		V
R _{INPAI}	input impedance	audio input path enabled		25		kΩ
R _{HINE}	impedance micgnd to vssa1	audio input path enabled			100	Ω
G _{SA}	gain step size		1.3	1.5	1.7	dB
N _{AGS}	number of gain steps			32		
G _{mA}	maximum gain			46.5		dB
G _{EAR}	gain error (accuracy of gain setting)	0 dB gain setting, full scale input voltage	-1	0	1	dB
ROES _{AI}	resolution audio input			12		bit
DNA _{AI}	differential non linearity audio input ADC				0.9	LSB
THUD _{AI}	total harmonic distortion	0db input gain selected 0.28Vpp, 1kHz to micp			0.03	%
THD _{MGA}	total harmonic distortion	46.5dB gain setting, 1mVpp, 1kHz to micp			0.1	%
SNR _{AI}	signal to noise ratio audio input	0dB input gain selected 0.28Vpp, 1kHz to micp	65			dB
SNR _{MGA}	signal to noise ratio	46.5dB gain selected 1mVpp, 1kHz to micp	50			dB
RIP _{IA}	pass band ripple	F _{PLA} < F _{sig} < F _{PHA}			0.5	dB
SBR _{IA}	stop band rejection audio input	F _{SHA} < F _{sig} < 20kHz	70			dB
E _{IA}	out of band rejection audio input	F > 20kHz		t.b.f.		mVrms

NOTE: Coding scheme for ADC output data is 2's complement.

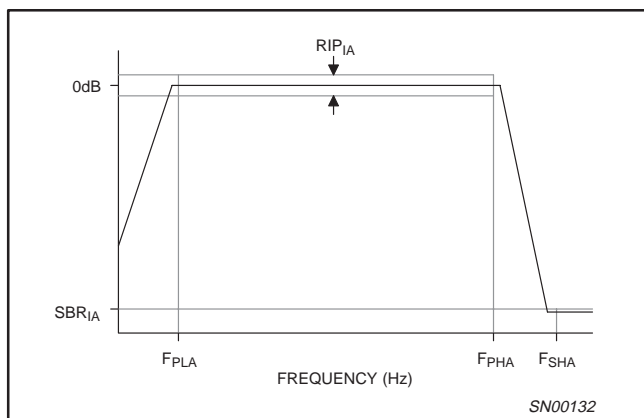

$$F_{PLA} = 0.00016 * F_{SA}$$

$$F_{PHA} = 0.42 * F_{SA}$$

$$F_{SHA} = 0.6 * F_{SA}$$

Figure 7. Audio Input Path Frequency Response

Advanced modem/audio analog front-end

UCB1100

6.1.2 Audio Output Specifications

SYMBOL	PARAMETER	CONDITIONS	LIMITS			UNIT
			MIN	TYP	MAX	
V _{OFFIA}	offset error	No signal applied to micp		0		LSB
V _{OOA}	full scale output voltage	0dB attenuation, 16ohm speaker differential Spkrp–Spkrn		3.2		V _{pp}
V _{OFFOA}	offset error	16ohm speaker			50	mV _{pp}
V _{SPK}	DC bias voltage spkrp and spkrn pin	Audio output path enabled		1.4		V
A _{SOA}	attenuation step size		2.8	3.0	3.2	dB
NSOA	number of attenuation steps			24		
A _{MOA}	maximum attenuation			69		dB
ROES _{OA}	resolution			12		bit
DNA _{OA}	differential non linearity DAC				0.9	LSB
THUD _{OAS}	total harmonic distortion 16Ω speaker	0dB attenuation 20Hz to 20kHz		0.5	2	%
THUD _{OA} H	total harmonic distortion 1kΩ headphone	0dB attenuation 20Hz to 20kHz bandwidth			0.03	%
SNR _{OAS}	signal to noise ratio 16Ω speaker	0dB attenuation 20Hz to 20kHz bandwidth	40	80		dB
SNR _{OA} H	signal to noise ratio, 1kΩ headphone	0dB attenuation 20Hz to 20kHz bandwidth	65	80		dB
RIP _{OA}	pass band ripple	F _{PLA} < F _{sig} < - F _{PHA}			0.5	dB
F _{SUOA}	cut off frequency upper stop band				0.6	F _{SA}
SBR _{OA}	stop band rejection	F _{SHAO} < F _{sig} < 20kHz	70			dB
E _{IOA}	integrated out of band energy	F > 20kHz		30		mVrms
Z _{SPKR}	speaker impedance		8	16		Ω

NOTE: Coding scheme for DAC input data is 2's complement.

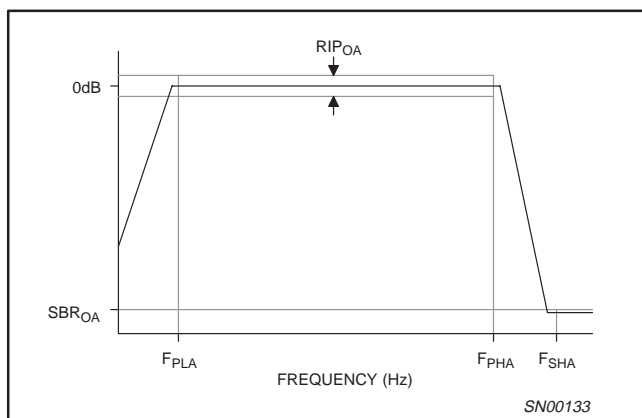

$$F_{PLA} = 0.00016 * F_{SA}$$

$$F_{PHA} = 0.42 * F_{SA}$$

$$F_{SHA} = 0.6 * F_{SA}$$

Figure 8. Audio Output Filter Frequency Response

Advanced modem/audio analog front-end

UCB1100

6.2 Telecom codec

The telecom codec contains an input channel, built up from a 64 times oversampling sigma delta analogue to digital converter (ADC) with digital decimation filters, programmable attenuation and build in sidetone suppression circuit. The output path consist of a digital up sample filter, a 64 time oversampling 4 bit digital to analogue converter (DAC) circuit followed by a differential output driver, capable of directly driving a 600ohm isolation transformer. The output path includes a mute function. The telecom codec also incorporates a loopback mode, in which codec output path and the input path are connected in series.

The telecom sample rate is derived from the SIB interface clock pin (sibclk) and is programmable through the SIB interface. The telecom sample rate is given by the following formula:

$$F_{st} = \frac{(2 * F_{sibclk})}{(64 * telecom_divisor)} \quad (5 < telecom_divisor < 128)$$

For example, a sibclk of 10 MHz, with a divisor of 40, results in a telecom sample rate of 7.813kHz. Both the rising and the falling

edges of the sibclk are used in case an odd telecom_divisor is set. In that case a 50% duty cycle of the sibclk signal is mandatory to obtain time equidistant sampling.

The input path of the telecom codec has a programmable attenuation. It also implements a voice band filter, which consists of a digital low pass filter, which is a part of the decimation filter. Therefore the pass band of the voice band filter is determined by the selected telecom codec sample rate. This voice band filter is activated by the *high pass enable* bit in the telecom control register B. The resulting telecom input filter curves are given in Figures 11 and 12.

The output section of the telecom codec is designed to interface with a 600 ohm line through an isolation transformer. The built in mute function is activated by the *mute* bit in the telecom control register B. The output driver remains active in the mute mode, however no output signal is produced.

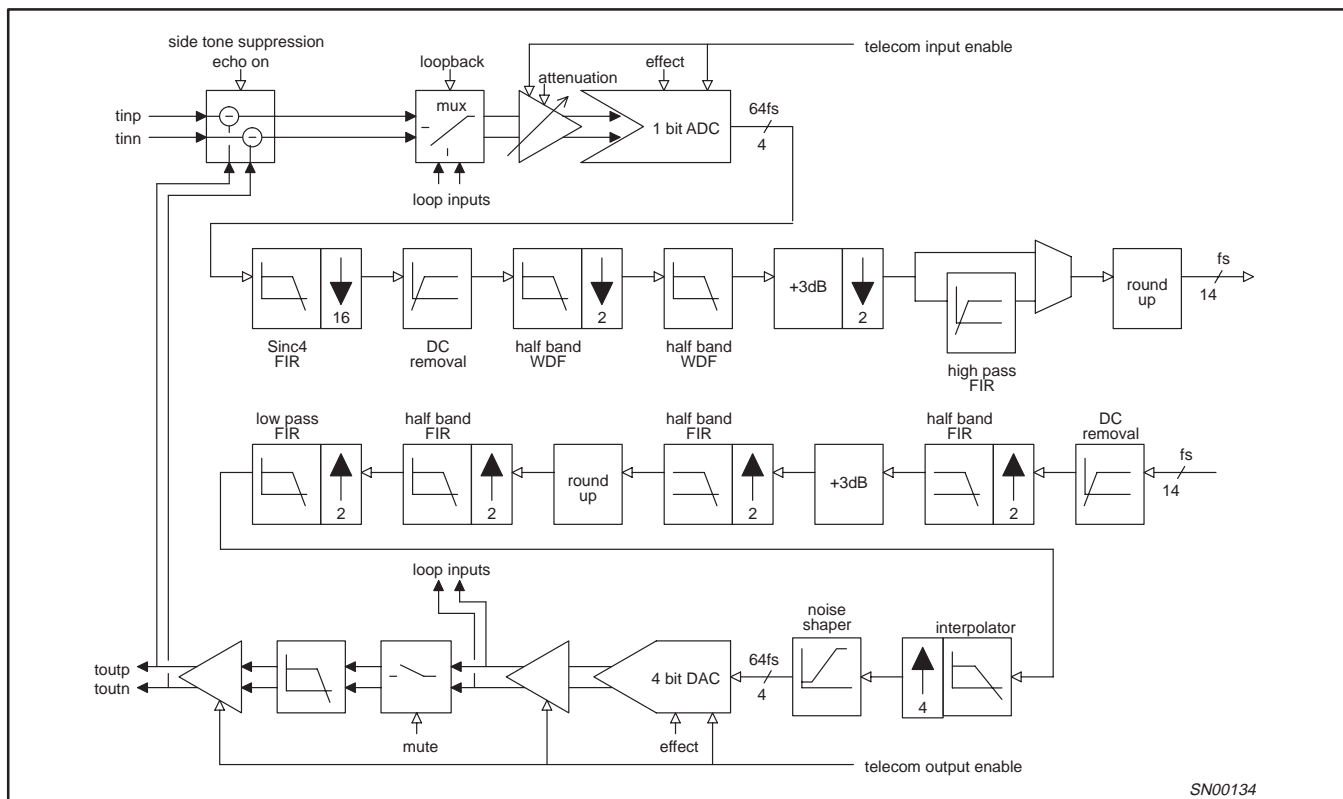

Figure 9. Detailed Block Diagram Telecom codec

Advanced modem/audio analog front-end

UCB1100

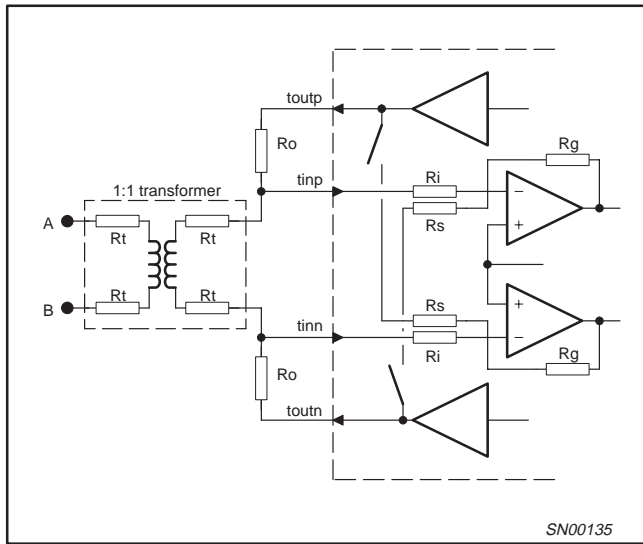

Figure 10. Telecom codec Sidetone Suppression Circuitry Shown with the Typical Connection between UCB1100 and Telephone Line (No Protections Circuits Shown)

An important built in feature of the telecom codec is the sidetone suppression circuit. The sidetone suppression circuit is activated when the *sidetone suppression enable* bit in the telecom control register B is set. The telecom input signal contains a large part of the telecom output signal *Tout*, when the sidetone suppression circuit is disabled. The available dynamic range of the telecom input is occupied largely by the telecom output voltage.

The sidetone suppression circuit subtracts a part of the telecom output signal from the telecom input signal when activated. The available dynamic range is in that case used more effectively than without sidetone suppression.

The built in side tone suppression circuit, shown in Figure 9, has a fixed subtraction ratio, set by the resistors *Rs* and *Ri*, which equals 600 / 456. This ratio is calculated from the following relations:

The impedance seen by the telephone line equals:

$$R_{line} = 2 * \left(R_t + R_t + \frac{R_o * R_i}{R_o + R_i} \right)$$

In which *Rt* represents winding resistance of the transformer, divided by 2. Assuming *Ri* >> *Ro* then

$$R_{line} = R_t + R_t + R_o = \frac{600}{2} = 300$$

A typical transformer has 156 ohm winding impedance, thus *Re* should be 144 ohm. The ratio of the telecom input and output voltage is therefore

$$T_{in} = T_{out} * \frac{156 + 300}{156 + 300 + 144} = T_{out} * \frac{456}{600}$$

Advanced modem/audio analog front-end

UCB1100

6.2.1 Telecom Input Specifications

SYMBOL	PARAMETER	CONDITIONS	LIMITS			UNIT
			MIN	TYP	MAX	
F_{ST}	sample frequency				10	kHz
V_{INTM}	full scale input voltage	0 dB attenuation setting		0.519		V_p
V_{TIN}	DC bias voltage T_{inp} / T_{inn} pins	telecom input path enabled		1.4		V
A_{SIT}	attenuation step size			6		dB
N_{STI}	number of attenuation steps			2		
A_{MTI}	maximum attenuation			6		dB
A_{ERTI}	attenuation error (accuracy of attenuation setting)	0 dB attenuation setting, full scale input voltage	-0.5	0	0.5	dB
R_{TI}	input impedance			25		k Ω
$SINAD_{TI}$	total harmonic distortion + noise to signal ratio	full scale input signal	70			dB
$SINAD_{TIS}$	total harmonic distortion + noise to signal ratio	-43dBm input voltage	32			dB
DNL_{TI}	differential non linearity ADC				2	LSB
RES_{TI}	resolution			14		bit
RIP_{TI}	pass band ripple, no voice filter	$F_{PLTI} < F_{sig} < F_{PHTI}$			0.6	dB
RIP_{VTI}	pass band ripple, voice filter activated	$F_{VHTI} < F_{sig} < F_{PHTI}$			0.6	dB
SBR_{VTI}	stop band rejection, voice filter activated	$F_{sig} < F_{VLT I}$	30			dB
SBR_{HTI}	stop band rejection	$F_{SHTI} < F_{sig} < F_{ST}$	55			dB
S_{SUP}	sidetone suppression effectiveness	600 Ω line, 1:1 line transformer with 156 Ω winding resistance	20			dB

NOTE: Coding scheme for ADC output data is 2's complement.

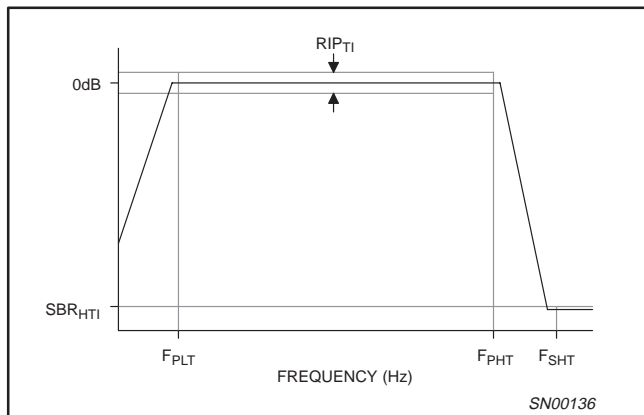

Figure 11. Telecom Input Frequency Response, No Voice Filter

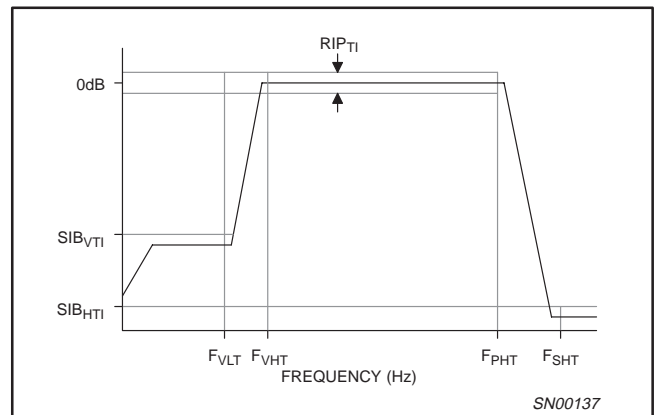

Figure 12. Telecom Input Frequency Response, Voice Filter Enabled

$F_{PLT} = 0.00016 * F_{ST}$ $F_{PHT} = 0.42 * F_{ST}$ $F_{SHT} = 0.6 * F_{ST}$ $F_{VLT} = 0.018 * F_{ST}$ $F_{VHT} = 0.05 * F_{ST}$
--

Advanced modem/audio analog front-end

UCB1100

6.2.2 Telecom Output Specifications

SYMBOL	PARAMETER	CONDITIONS	LIMITS			UNIT
			MIN	TYP	MAX	
F_{ST}	sample frequency				10	kHz
V_{OOT}	full scale output voltage	differential Toutp/Toutn		4.0	4.4	V_{pp}
V_{TOUT}	DC bias voltage Toutp / Toutn pins	telecom output path enabled		1.4		V
$ROES_{TO}$	resolution			14		bit
$SINAD_{TO}$	signal to noise + distortion			75		dB
RIP_{TO}	pass band ripple				0.6	dB
RIP_{VTO}	pass band ripple, voice band filter activated				0.6	dB
SBR_{VTO}	stop band rejection, voice filter activated	$F_{sig} < F_{VLT}$				
SBR_{TO}	stop band rejection	$F_{SHT} < F_{sig}$	70			dB
E_{ITO}	integrated out of band energy	Frequencies $> F_{ST}$		25		mVrms
Z_{TELTO}	minimal load impedance		600			Ω
V_{OFFTO}	offset error (deviation of the analogue output from zero with 0 code input to telecom out- put path)	1200 Ω load			50	mV

NOTE: Coding scheme for the DAC input data is 2's complement.

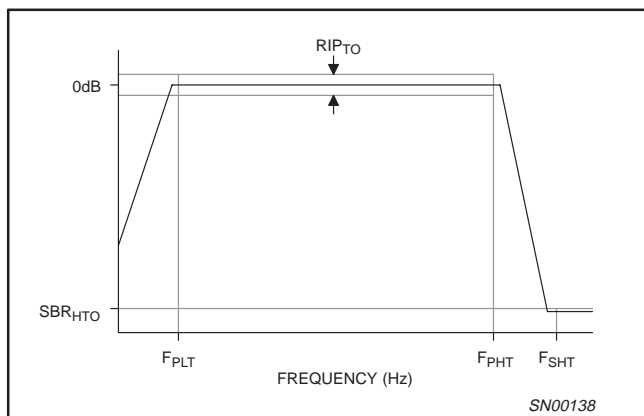

$$F_{PLT} = 0.00016 * F_{ST}$$

$$F_{PHT} = 0.42 * F_{ST}$$

$$F_{SHT} = 0.6 * F_{ST}$$

Figure 13. Telecom Output Frequency Response, No Voice Filter

Advanced modem/audio analog front-end

UCB1100

6.3 Touch Screen Measurement Modes

The UCB1100 contains an on chip interface for a 4 wire resistive touch screen. This interface supports three modes of touch screen measurements, position, pressure and plate resistance.

6.3.1 Position Measurement

Two position measurements are needed to determine the location of the pressed spot. First an X measurement, secondly a Y measurement. The X plate is biased during the X position measurement the X plate and the voltage on one or both Y terminals (tspy, tsm_y) measured. The circuit can be represented by a potentiometer, with the tspy and/or tsm_y electrode being the 'wiper'. The measured voltage on the tspy/tsm_y terminal is proportional to the X position of the pressed spot of the touch screen.

In the Y position mode the X plate and Y plate terminals are interchanged, thus the Y plate is biased on the voltage on the tsp_x and/or tsm_x terminal is measured.

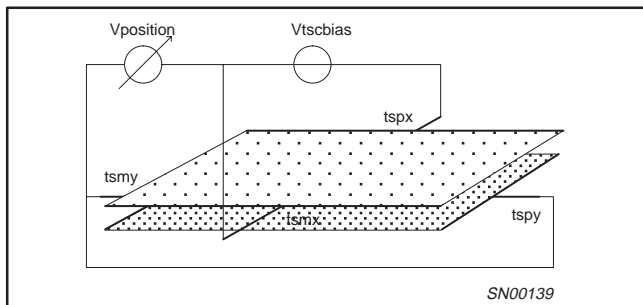

Figure 14. Touch Screen Setup for Position Measurement

6.3.2 Pressure Measurement

The pressure used to press the touch screen can be determined. In fact the contact resistance between the X and Y plate is measured, which is a good indication of the size of the pressed spot and the applied pressure. A soft stylus, e.g. a finger, leads to a rather large contact area between the two plates when a large pressure is applied. A hard stylus, e.g. a pen, leads to less variation in measured contact resistance since the contact area is rather small.

One plate is biased at one or both terminals during this pressure measurement, whereas the other plate is grounded, again on one or both terminals. The current flowing through the touch screen is a direct indication for the resistance between both plates. A compensation for the series resistance, formed by the touch screen plates itself will improve the accuracy of this measurement.

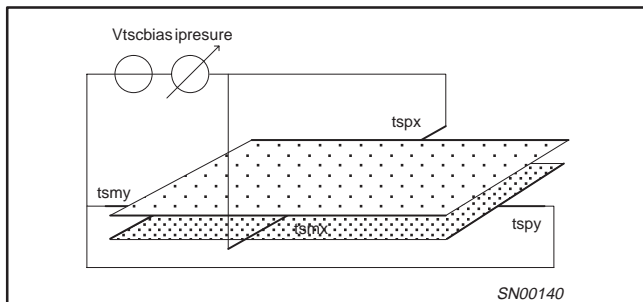

Figure 15. Touch Screen Setup for Pressure Measurement

6.3.3 Plate Resistance Measurement

The plate resistance of a touch screen varies typically a lot due to processing spreads. Knowing the actual plate resistance makes it possible to compensate for the plate resistance effects in the pressure resistance measurements. Secondly the plate resistance decreases when two or more spots on the touch screen are pressed. In that case a part of one plate, e.g. the X plate is shorted by the other plate, which decreases the actual plate resistance.

The plate resistance measurement is executed in the same way as the pressure resistance measurement. In this case only one of the two plates is biased and the other plate is kept floating. The current through the connected plate is again a direct indication of the connected resistance.

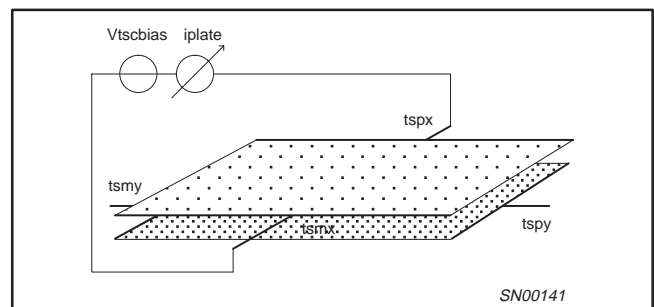

Figure 16. Touch Screen Setup for Plate Resistance Measurement

Advanced modem/audio analog front-end

UCB1100

6.4 Touch Screen Interface

The UCB1100 contains a universal resistive touch screen interface for 4 wire resistive touch screen, capable of performing both position, pressure and plate resistance measurements. In addition the touch screen can be programmed to generate interrupts when the touch screen is pressed. The last mode is also active when the UCB1100 is set in the standby mode.

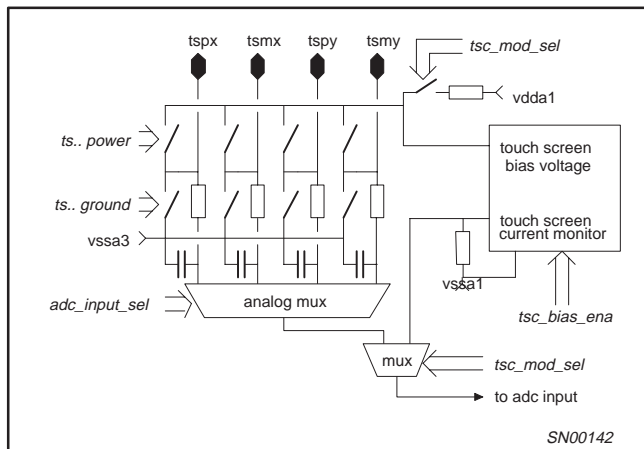

Figure 17. Block Diagram of the Touch Screen Interface

The touch screen interface connects to the touch screen by four wires: tspx, tsmx, tspy and tsmy. Each of these pins can be programmed to be floating, powered or grounded in the touch screen switch matrix. The setting of each touch screen pin is programmable by the *power ts..* and *ground ts..* bits in the touch screen control register. Possible conflicting settings (grounding and powering of a touch screen pin at the same time) are detected by the UCB1100. In that case the UCB1100 will ground the touch screen pin.

The UCB1100's internal voltage reference (*Vref*) is as reference voltage for the touch screen bias circuitry. This makes the touch screen biasing independent of supply voltage and temperature variations. Four low pass filters, one on each touch screen terminal, are built in to minimize the noise coupled from the LCD into the touch screen signals. An LCD typically generates large noise glitches on the touch screen, since they are closely coupled.

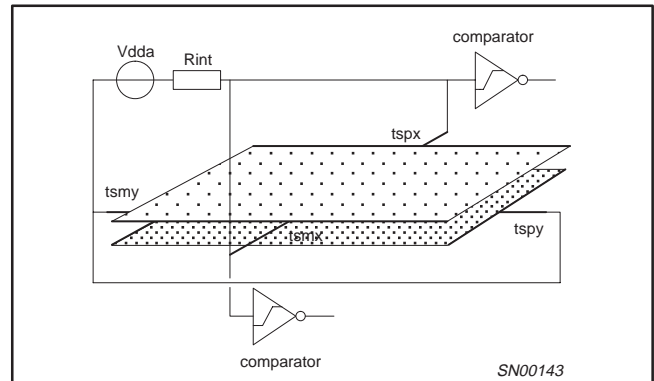

Figure 18. Touch Screen Setup for Interrupt Detection

In addition to the measurements made above, the touch screen can also act as an interrupt source. In this mode the X plate of the touch screen has to be powered and the Y plate has to be grounded. In this case the touch screen is not biased by the active touch screen bias circuit, but by a resistor to *vdda1*. This configuration simply biases the touch screen and the UCB1100 does not consume power unless the touch screen is touched. The voltage on the X plate terminal drops if the screen is pressed. This voltage drop is detected by Schmitt trigger circuits, of which the outputs are connected to the interrupt control block. An touch screen interrupt is generated either when the touch screen is pressed (falling edge enabled) or when the touch screen is released (rising edge enabled). which can be used to activate the system around the UCB1100 to start a touch screen readout sequence. The internal Schmitt trigger circuits are connected to the *tspx* and *tsmx* signals after the built in low pass filters. This reduces the number of spurious interrupts, due to the coupling between the LCD screen and the touch screen sensors.

Each of the four touch screen signals can be selected as input for the built in 10 bit ADC, which is used to determine the voltage on the selected touch screen pin. The flexible switch matrix and the multi functional touch screen bias circuit enables the user of the UCB1100 to set each desired touch screen configuration.

The setting of the touch screen bias circuitry and the *adc_input* multiplexer is determined by the setting of the *tsc_mod_sel* bits in the touch screen control register according the following table.

Advanced modem/audio analog front-end

UCB1100

TOUCH SCREEN MODE SELECTION

tsc_mod_sel bits	selected mode	touch screen bias source	'selected' adc input
00	interrupt	resistor to vdda1	defined by adc_input_sel bits
01	pressure	touch screen bias circuit	touch screen current monitor
10	position	touch screen bias circuit	defined by adc_inp_sel bits
11	position	touch screen bias circuit	defined by adc_input_sel bits

SUMMARY OF TOUCH SCREEN MODES

Touch screen measurement	tsp _x	tsm _x	tsp _y	tsm _y	touch screen mode	touch screen bias
X position	powered ¹	grounded ¹	adc input ²	adc input ²	position	enabled
Y position	adc input ²	adc input ²	powered ¹	grounded ¹	position	enabled
pressure – 1	powered ¹	powered ¹	grounded ¹	grounded ¹	pressure	enabled
pressure – 2	powered	floating	grounded	floating	pressure	enabled
pressure – 3	floating	grounded	powered	floating	pressure	enabled
pressure – 4	floating	powered	floating	grounded	pressure	enabled
pressure – 5	grounded	floating	floating	powered	pressure	enabled
X plate resistance	powered ¹	grounded ¹	floating	floating	pressure	enabled
Y plate resistance	floating	floating	powered ¹	grounded ¹	pressure	enabled
interrupt	powered	powered	grounded	grounded	interrupt	disabled ³

NOTES:

1. The powered and grounded touch screen pins may be interchanged.
2. One of the two indicated touch screen pins have to be selected.
3. **The touch screen bias has to be disabled in this mode by the user, to prevent false interrupts.**

6.4.1 Touch Screen Specifications

SYMBOL	PARAMETER	CONDITIONS	LIMITS			UNIT
			MIN	TYP	MAX	
V _{TSCBIAS}	touch screen bias voltage	touch screen position mode selected		1.8		V
I _{TSCMAX}	maximum touch screen current	touch screen position mode selected	10			mA
R _{TSCINT}	maximum touch screen resistance to generate an interrupt	touch screen interrupt mode selected			2500	Ω
R _{SWGND}	on resistance ground switch	touch screen pin programmed grounded			50	Ω
t _{TSCSTR}	start up time touch screen bias voltage generator				25	μs

Advanced modem/audio analog front-end

UCB1100

6.5 10 bit ADC

The UCB1100 includes a 10 bit successive approximation analogue to digital converter (ADC) with built in track and hold circuitry, an analogue multiplexer to select 4 analogue inputs or the 5 touch screen voltages and 4 switched resistive voltage dividers on the analogue ad0–3 high voltage inputs. The ADC is used to readout the touch screen inputs and it measures the voltage on the four analogue high voltage inputs ad0–3.

The ADC is controlled through the SIB interface. It is enabled by the *adc_enable* bit in register 10; the ADC circuitry, including the track and hold circuitry does not consume any power when it is not enabled.

A complete analogue to digital conversion consists of several phases. First the ADC input selector must be set to the proper input. Secondly the track and hold must track the signal; this requires a certain settling time if the adc input was changed. After this time the sample is taken. A calibration of the ADC circuitry is performed before the actual conversion starts. The result of the conversion is stored in the register 11 of the SIB interface, after the completion of

the conversion. An interrupt may be generated whenever a conversion is completed, depending of the setting of the *adc_interrupt_ena* bits in the sib register 2 and 3. The *adc_data_valid* bit in the SIB register 11 indicates the status of the ADC; it equals '0' when a ADC sequence is started and it equals '1' when the ADC result is stored in the SIB register 11.

The ADC sequence is started in two ways. First it starts whenever the *adc_start* bit in register 10 is changed from '0' to '1'; this is the case when the *adc_sync_ena* bit in registers 10 equals '0' (=default). Internal logic determines whether the adc input multiplexer setting was changed in the sib frame, carrying the *adc_start* bit transition. If this is the case, an additional tracking time is added automatically.

The second mode of operation is activated when the *adc_sync_ena* bit is set to '1'. In this mode the ADC conversion is not started by an '0' to '1' transition of the *adc_start* bit, but is 'armed'. During the arming situation the track and hold circuit tracks the selected input signal. A sample is taken and the actual ADC conversion is started when a rising edge is detected on the *adcsync* input pin.

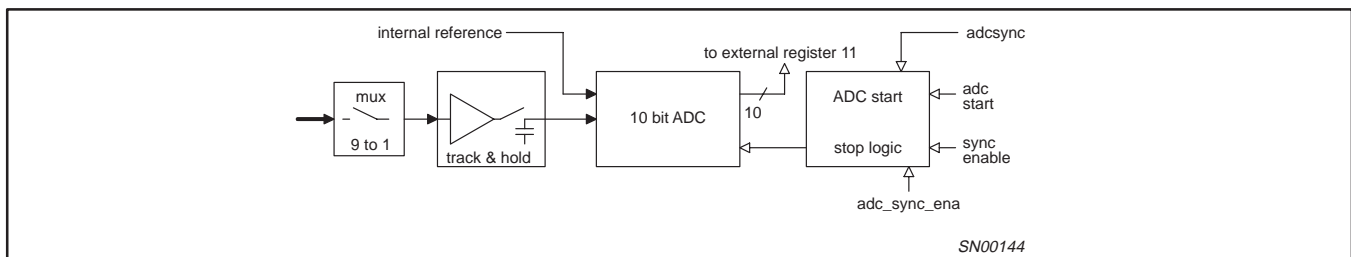

Figure 19. Block Diagram of the 10 bit ADC Circuit

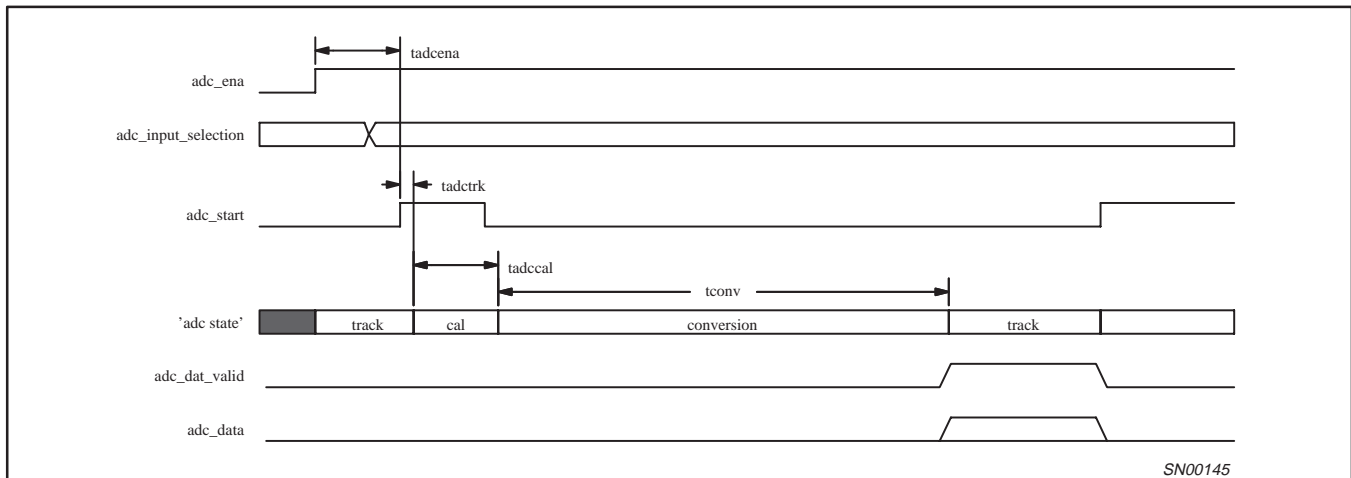

Figure 20. Timing Diagram of an ADC Conversion Sequence (*adc_sync_ena*='0')

Advanced modem/audio analog front-end

UCB1100

The ADC sequence is started in two ways. First it starts whenever the *adc_start* bit in register 10 is changed from '0' to '1'; this is the case when the *adc_sync_ena* bit in registers 10 equals '0' (=default). Internal logic determines whether the adc input multiplexer setting was changed in the sib frame, carrying the *adc_start* bit transition. If this is the case, an additional tracking time is added automatically.

The second mode of operation is activated when the *adc_sync_ena* bit is set to '1'. In this mode the ADC conversion is not started by an '0' to '1' transition of the *adc_start* bit, but is 'armed'. During the arming situation the track and hold circuit tracks the selected input signal. A sample is taken and the actual ADC conversion is started when a rising edge is detected on the *adcsync* input pin.

The internal ADC start logic adds a fixed tracking time, when the ADC input multiplexer was changed in the SIB frame with the '0' to '1' transition of the *adc_start* bit. A rising edge on the *adcsync* pin will not have any effect during this tracking time; the ADC sequence

will start on the first detected rising edge on the *adcsync* pin after this tracking time.

This mode is particularly useful when the internal ADC has to be synchronized with the external systems. Typically it is used to synchronize the readout of the touch screen with the driving of the LCD screen, which is normally placed in the direct neighborhood of the touch screen. Many spikes and a lot of 'noise' are superposed on the touch screen signals, due to the close coupling of the touch screen and the LCD.

The UCB1100 contains four high voltage analogue inputs *ad0*–*ad3* which can be selected by the ADC input multiplexer, besides the already discussed touch screen interface signals. These high voltage inputs optimized to handle voltages larger than the applied supply voltage. The built in resistive voltage divider are only activated if the corresponding analogue input is selected. The not selected *ad0*–*ad3* inputs are high ohmic resulting in minimal leakage input leakage of these pins.

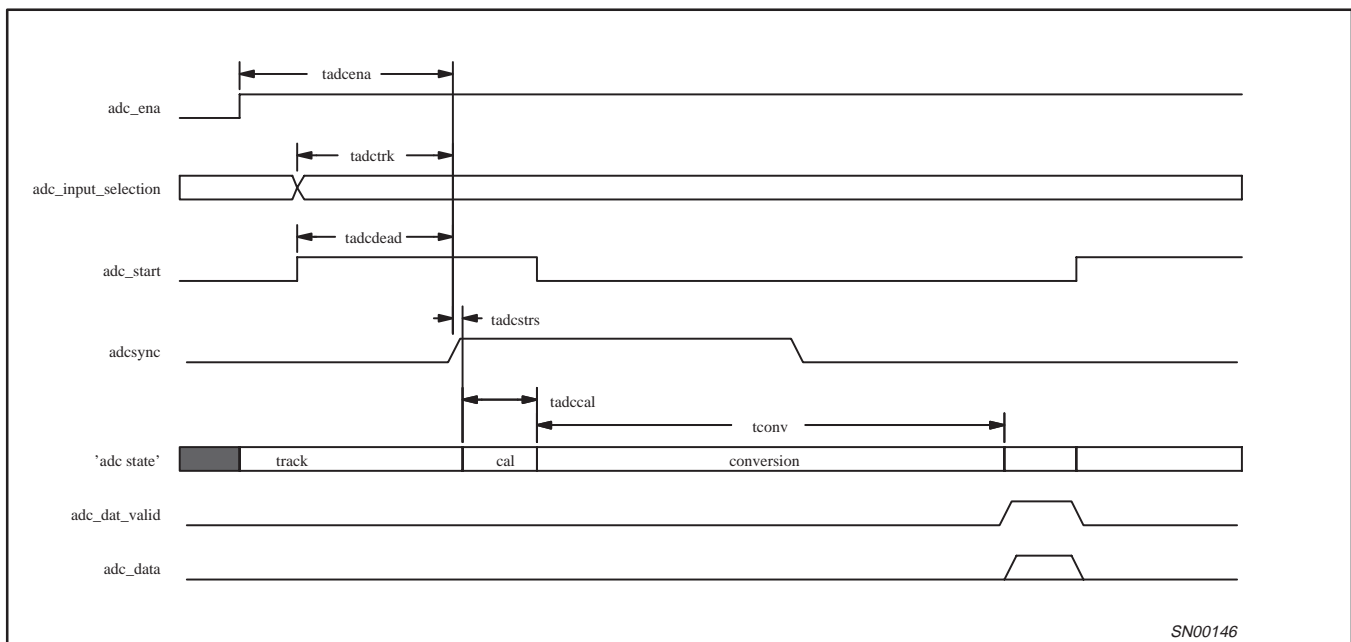

Figure 21. Timing Diagram of an ADC Conversion Sequence (*adc_sync_ena*='1')

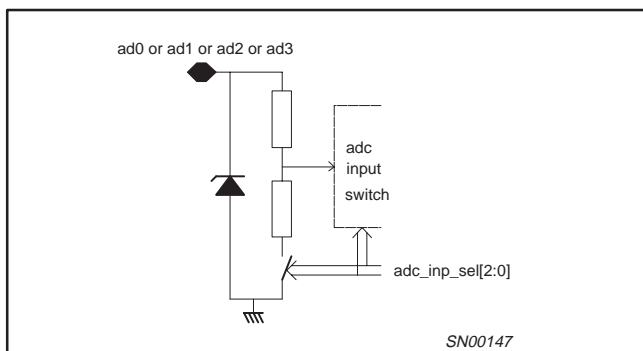

Figure 22. *ad0*–*ad3* Resistive dividers

Advanced modem/audio analog front-end

UCB1100

6.5.1 Specification Overview

SYMBOL	PARAMETER	CONDITIONS	LIMITS			UNIT
			MIN	TYP	MAX	
RES _{ADC}	resolution of ADC			10		bit
V _{FSad}	full scale ad0–3 inputs		7.17	7.5	7.9	V
R _{INad}	input impedance selected ad0–3 pin		50	75	100	Ω
I _{Lad}	input leakage current, non selected ad0–3 pins			<1	10	μA
DNL _{ADC}	differential non-linearity			0.1	0.5	lsb
INL _{ADC}	integral non linearity			0.5	2	lsb
t _{conv}	conversion time			110		t _{sibclk}
t _{adccal}	settling time			10		t _{sibclk}
t _{adctrk}	tracking time no adc input change adc input change	adc_sync_ena='0'	50		1	t _{sibclk} t _{sibclk}
t _{adctrks}	tracking time no adc input change adc input change	adc_sync_ena='1'	50		25	ns t _{sibclk}
t _{hadcsync}			10			ns
t _{padcsync}						

6.6 On Chip Reference Circuit

The UCB1100 contains an on chip reference voltage source, which generates the reference voltages for the 10 bit ADC and the necessary internal reference voltages. Alternatively, the UCB1100 can be driven from an external reference voltage source.

The internal reference voltage can be monitored and filtered additionally on the vrefbyp pin. Two bits in the ADC control register determine the mode of operation of this reference voltage circuit. The vrefbyp_con bit connects the internal reference voltage to the vrefbyp pin, while the ext_vref_ena bit disables the internal reference voltage and switches the UCB1100 into the external voltage reference mode.

The internal reference circuit is activated only when one or more analogue functions inside the UCB1100 is activated. This reduces the current consumption of the analogue part in standby mode. The external reference voltage source is also disconnected when all analogue functions are disabled.

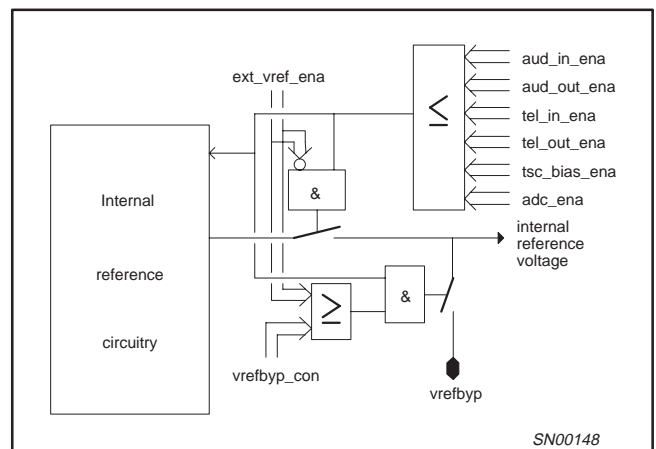

Figure 23. Block Diagram of the Reference Circuit

6.6.1 Specification Overview

SYMBOL	PARAMETER	CONDITIONS	LIMITS			UNIT
			MIN	TYP	MAX	
V _{REF}	reference voltage		1.1	1.2	1.3	V
t _{refstrt}	start up time of internal reference voltage circuit				50	t _{sibclk}

Advanced modem/audio analog front-end

UCB1100

6.7 Serial Interface Bus

The UCB1100 serial interface bus (SIB) is compatible with industry standard serial ports and devices, and is designed to connect directly to a system controller. The sib protocol allows one or more slave devices to be connected to the system controller. The data transfer is always synchronous and it is frame based. The SIB interface consists of four signals: sibddn, sibdout, sibclk and sibsync.

Each SIB frame consists of at least 64 clock cycles. Typically 128 bits are used, divided into 2 sub frames of 64 bits each. The first word (the bits 0 to 63) is read and/or written by the UCB1100, the remaining bits may be used for communication between the system controller and another slave device. The sibdout pin of the UCB1100 is default-stated for the bit 64 and higher in the SIB frame to prevent bus conflicts with other slave devices. However when the sib_zero_ena bit (control register 1) is set, the sibdout pin is forced to zero for bit 64 and higher to prevent floating of the sibdout line during this part of the sib frame in case when the UCB1100 is the only slave device connected to the bus.

The UCB1100 always samples incoming data on the sibdin pin on the falling edge of sibclk and it outputs data on the sibdout pin on the rising edge of the sibclk. The start of a new sib frame is indicated by a pulse on the sibsync line just before the start of this new sib frame.

The applied clock signal to the sibclk pin is used as clock signal inside the UCB1100; all internal clock signals are derived from that. It is required that the sibclk signal is applied if one or more analogue or digital functions is activated in the UCB1100; only the interrupt controller is implemented synchronously. The sibclk may be stopped when all digital and analogue functions are disabled; in that case the lowest possible power consumption is met. The sibclk should not be stopped during a sib frame, but only at the end of the sib-frame, to ensure that all analogue and digital functions are stopped properly.

NOTE: The interrupt controller is still active, due to its asynchronous implementation. The UCB1100 can therefore still generate interrupts to the system controller, when the sibclk is stopped.

The generation of the audio and telecom sample clocks require that the sibclk signal is symmetrical: a non symmetrical sibclk will lead to non equidistant sample moments, when an odd frequency divisor is set in either of the audio or telecom control registers.

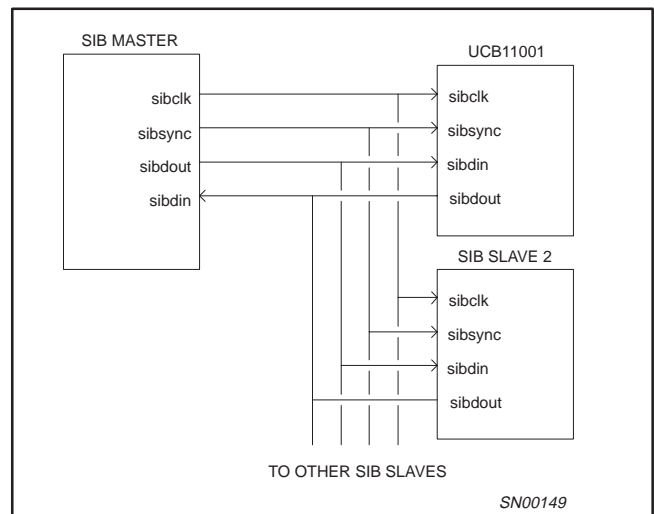

Figure 24. Typical Connection Between the UCB1100 and the System Controller

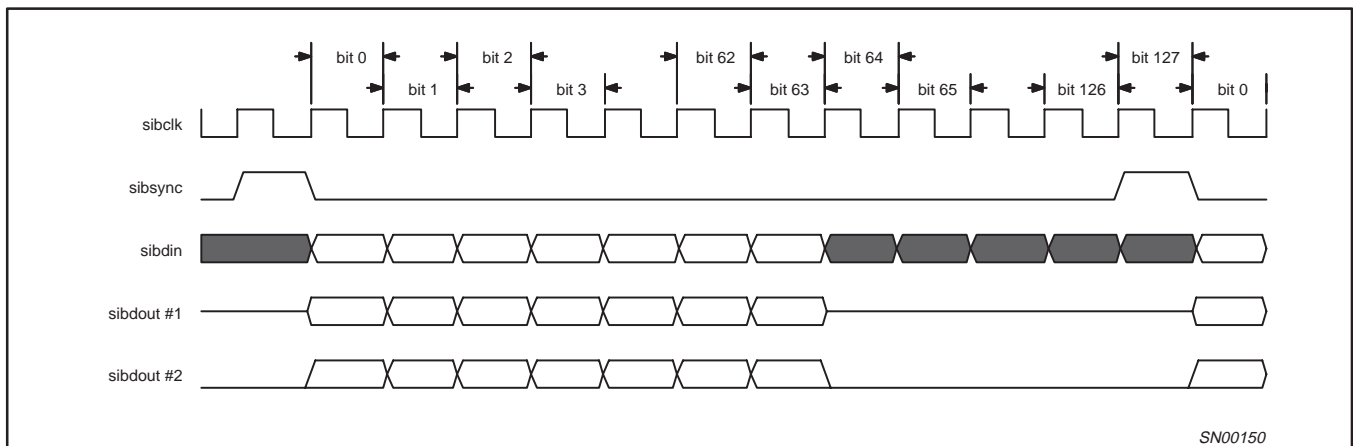

Figure 25. Serial Data Transmission of the UCB1100, sibdout #1 in case sib_zero bit = '0', sibdout #2 in case sib_zero bit = '1'

Advanced modem/audio analog front-end

UCB1100

6.7.1 SIB Data Format

The first 64 bits in the sib-frame are read and written by the UCB1100 and they contain both audio and telecom codec data fields, several control bits and a control register data field as is defined in table below.

Sib frame bit	SIBDin field definition	SIBDout field definition
15–0	audio input path data [15:0]; bit 0 = MSB, the 12 MSB bits are read.	audio output path data [15:0]; bit 0 = MSB, the bits [15:12] are '0'
16	not read but reserved	fixed '0'
20–17	control register address [3:0]; bit 0 = MSB	control register address [3:0]; bit 0 = MSB; = copy of the register address as present in the sibdin field in the same sib frame
21	write bit (write = 1)	fixed zero
29–22	not read but reserved	fixed zeros
30	audio valid sample flag	audio valid flag
31	telecom valid sample flag	telecom valid flag
47–32	telecom input path data [15:0]; bit 0 = MSB, the 14 MSB bits are read.	telecom output path data [15:0], bit 0 = MSB, the bits [15:14] are '0'
63–48	control register 'write data [15:0]; bit 0 = MSB	control register read data [15:0]; bit 0 = MSB

NOTE:

Since the data transfer is completely synchronous, a given control register may be written many times, before the device feeding the data has a chance to change the control bits. The UCB1100 does detect whether the data is changed or not.

Advanced modem/audio analog front-end

UCB1100

6.7.2 Codec Data Transfer

The audio and telecom codecs both operate at a programmable sample rate slower than the data transfer rate of the serial bus. The codecs sample the contents of the appropriate field each time their internal counters indicate that a new sample is necessary. They update the data read by the serial interface in the same manner. The counters for the audio and telecom subsystems are reset each time the respective subsection is turned on (whenever the audio/telecom input or output path enable bits are set) and counting begins at the next SIBSync input pulse (see Figure 26). The controlling devices must be both frequency and phase synchronized to the sample rate counters within the UCB1100 in order to ensure correct operation.

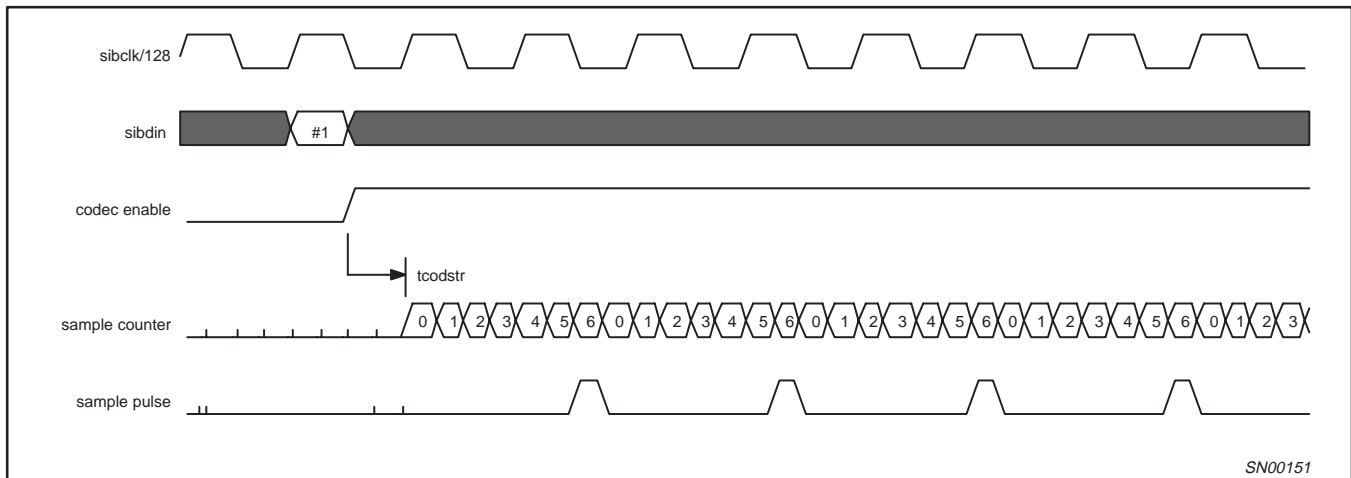

Figure 26. Start of the codec sample counters (divisor set to 7). Sibdin sub frame #1 contains the codec input and/or output path enable bit, the codec enable signal is the 'OR' function of the associated code input and output enable bit.

The codec data is loaded in the codec input register after the sub frame has been sent completely, when the appropriate data valid flag was set in the sib frame. The codec input data is not refreshed, whenever the audio and/or telecom data valid flag equals '0' in the sub frame or when no sibdin data is transmitted.

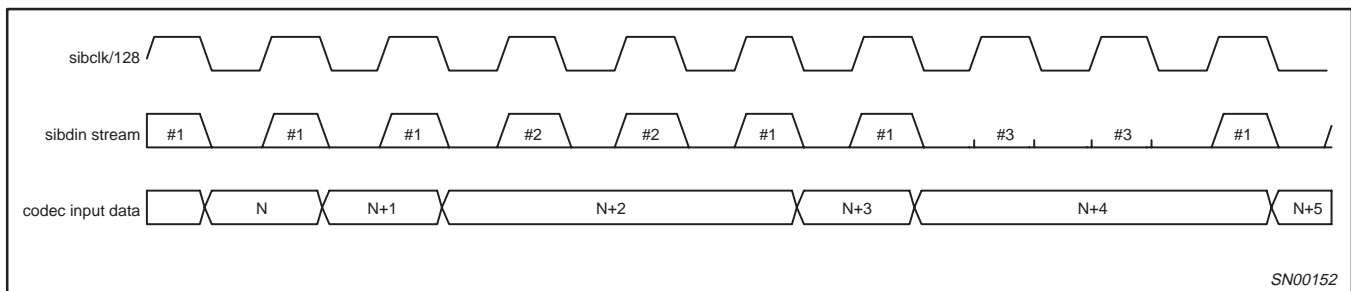

Figure 27. Codec input data handshake protocol, sibdin frame #1 contains codec data and the data valid flag equals '1', sib frame #2 contains codec data, but the data valid flag equals '0', sib frame #3 contains no data.

Codec data must be received by the UCB1100 in one of the SIB frames preceding the sample moment of the codec, it uses the last sample received before the sample moment. In case no refreshed codec data has been sent, the UCB1100 re-uses the available 'old' codec data sample. This will lead to high distortion in the codec circuits.

Advanced modem/audio analog front-end

UCB1100

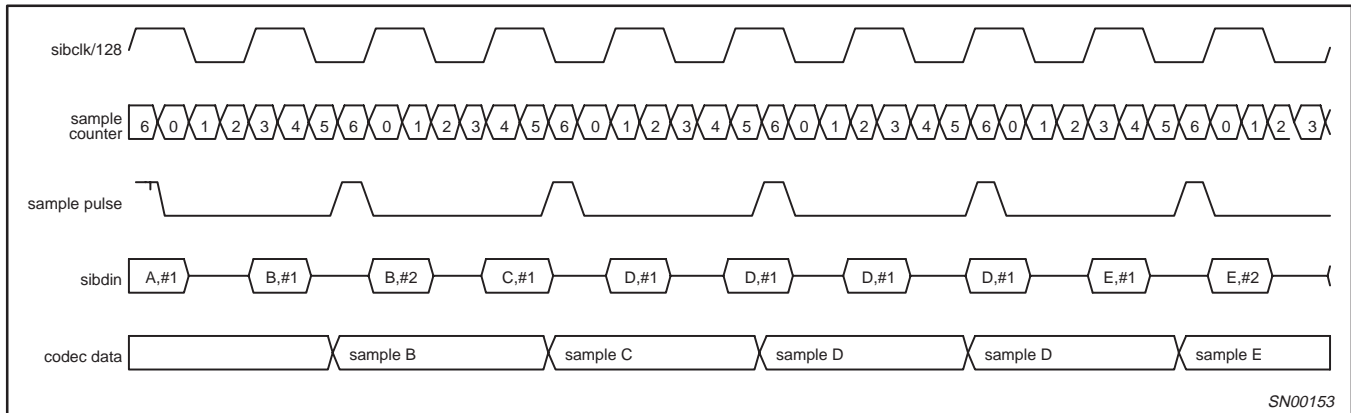

Figure 28. Codec input data transfer, sib frame x,#1 contains sample x data with the associate data valid flag set to '1', the sib frame indicated with x,#2 contain the codec sample x, with the associated data valid flag set to '0'.

The codec output data is transmitted in the first SIB frame following the sample moment of the codec. The sibdout data stream contains a data valid bit for each codec (bit 30 and bit 31) to simplify the data transfer from the UCB1100 to the system controller. The audio and telecom data valid bits are set to '1' in the sibdout data stream when the codec generate reliable data. This is the case when the codec circuitry is stabilized after it was enabled. This mode of operation is chosen when the *dyn_vflag_ena* bit (register 13) equals '0'. A second mode is available to simplify the transfer of data, which is set when the *dyn_vflag_ena* bit is set to '1'. In that case the audio and the telecom data valid flag bits will be '1' in the sib frame following the codec sample moment, which contains at all times the most recent codec result.

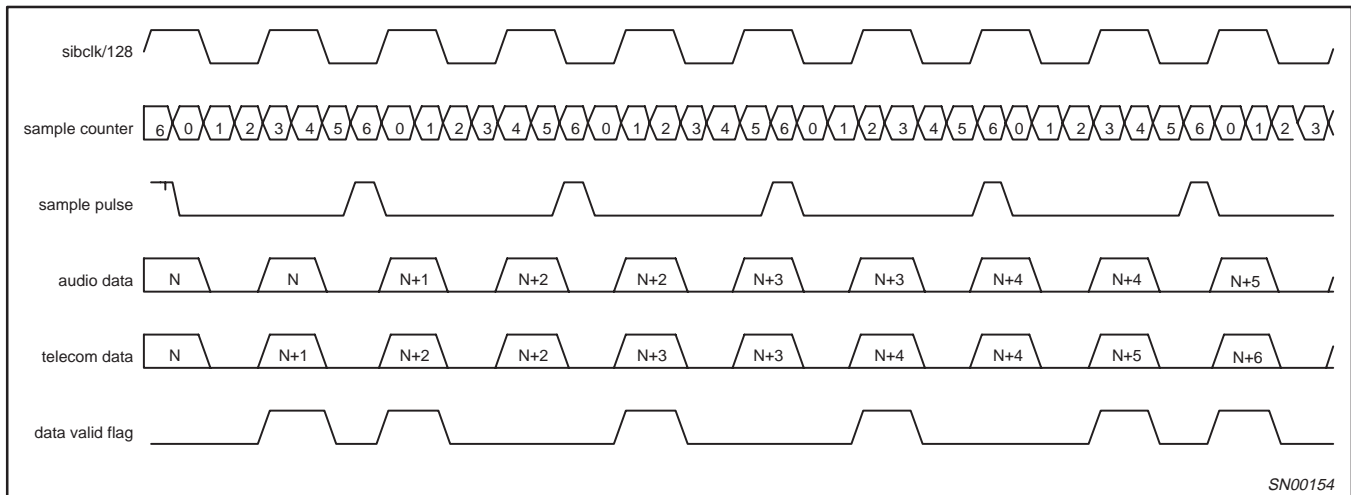

Figure 29. Sample counter synchronization (divisor set to 7), audio and telecom data placement shown in sibdout data stream, including the associated audio/telecom data valid flags (dynamic data valid flag mode).

The audio and telecom codec data each are positioned as if they had 16 bits of resolution. For the 12-bit audio codec the low 4 bits are ignored on input and forced to 0 on output. For the 14-bit telecom codec, the low 2 bits are treated similarly.

Advanced modem/audio analog front-end

UCB1100

6.7.3 Control Register Data Transfer

The last 16 bits of the UCB1100 word is made up of control register data. The selection of the control register and whether it is read or written is defined by the control register address field [bit 17:20] and the "write" bit [bit 21]. For a read action on the a control register, the control register address field has to set to the desired control register address and the "write" bit has to be set to zero in the SIBDin stream, The read data is sent by the UCB1100 within the control register data field of SIBDout during the **same** frame as the read request occurred. In addition, during a read cycle, the control register data field of SIBDin is ignored by the UCB1100 which implies that no modifications of the UCB1100 settings can be performed when the "write" bit equals zero in the SIBDin data-stream.

For a write cycle ("write" bit = 1), the control register data contents of SIBDin are written to the UCB1100 register selected by the register address field after receipt of the complete first word (the update is performed during the 64th bit in the SIB frame). This implies that the

control register data contents of SIBDout data-stream in a SIB frame represents the previous contents of the selected control register.

The control register address in the sibdout data-stream is a copy of the selected control register in the sibdin data-stream. These bits show an additional delay since they pass additional circuitry in the UCB1100.

The control register data is actually written in the control registers after the transfer of the first sib word is completed. This implies that the control register data is updated during bit 64 of the sib frame. The control data is only updated when the write bit is '1' in the sib frame. The control data will not be updated when the write bit equals '0'. This simplifies the read out of control register data, since it is not required to send 'valid' data in the control register data field when a control register is read, if the write bit is kept at '0'.

The control register data in the sibdout stream is sampled just before the sib frame is started. This implies that the returned control register data represents the 'old' control data, in case new data was provided in the sibdin data stream.

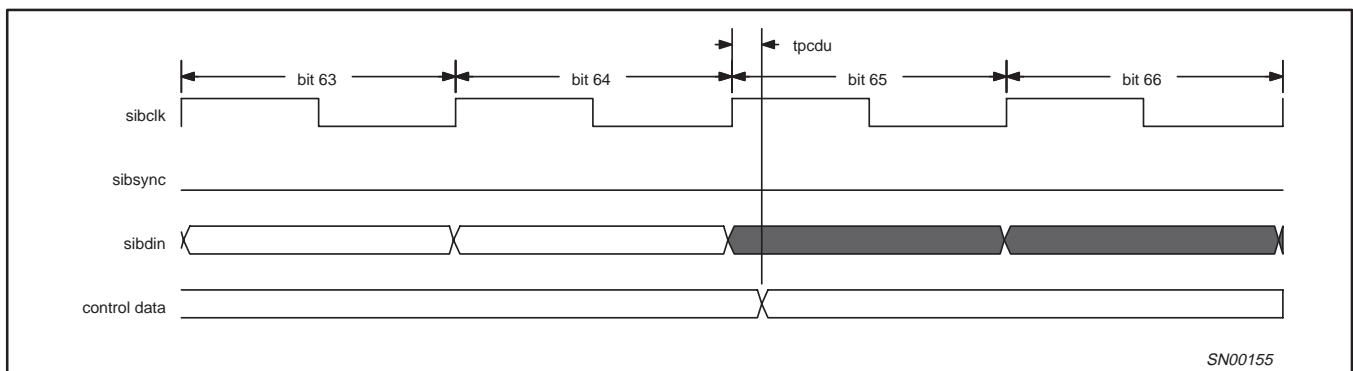

Figure 30. Control Register Update Timing

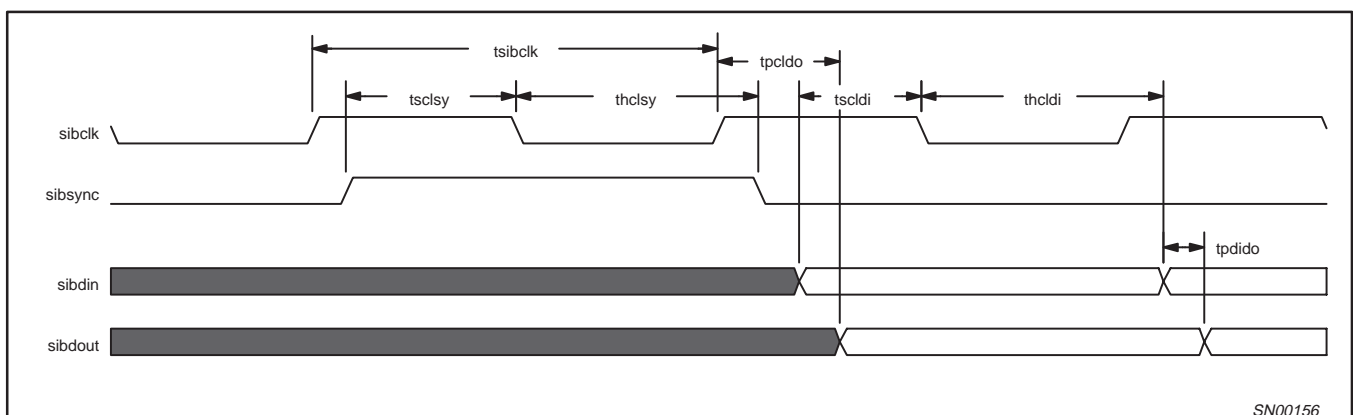

Figure 31. Timing Definitions SIB Interface

Advanced modem/audio analog front-end

UCB1100

6.7.4 AC Electrical Characteristics

$T_{amb} = 0^{\circ}\text{C}$ to 70°C , $V_{SSD} = V_{SSA1} = V_{SSA2} = V_{SSA3} = 0\text{V}$
 $V_{DD} = 3.3\text{V} \pm 10\%$, $V_{DDA1} = 3.3\text{V} \pm 10\%$, $V_{DDA2} = 3.3\text{V} \pm 10\%$

SYMBOL	PARAMETER	NOTES	LIMITS			UNIT
			MIN	TYP	MAX	
$1/t_{sibclk}$	sibclk input frequency		0		15	MHz
$t_{hsibclk}/t_{sibclk}$	duty cycle sibclk	Note 1		50		%
t_{sclsy}	sibsync valid to falling edge sibclk					ns
t_{hclsy}	sibsync hold after falling edge sibclk					ns
t_{scldi}	sibdin valid to falling edge sibclk					ns
t_{hcldi}	sibdin hold after falling edge sibclk					ns
t_{pcldo}	rising edge sibclk to valid sibdout	Note 2			20	ns
t_{hcldo}	sibdout hold after rising sibclk edge	Note 3				ns
t_{pdido}	valid sibdin to valid sibdout				25	ns
t_{pcdu}						

NOTES:

1. This is a requirement when an odd divisor is set either in the audio or in the telecom codec.
2. This is valid for all sib frame bits 0 to 63, except bits 17–20.
3. This is valid for the sib frame bits 17–20.

6.8 General Purpose IOs

The UCB1100 has 10 programmable digital input/output (IO) pins. These pins can be independently programmed as input or output using the $IO_mode[0:9]$ bits in the control register 1. The output data is determined by the content of the io_data bits in the control register 0, while the actual status of these pins can be read from the $io_data[0:9]$ bits in the control register 0.

The data on the $io[0:9]$ pins are feed into the interrupt control block, where they can generate an interrupt on the rising and/or falling edge of these signals.

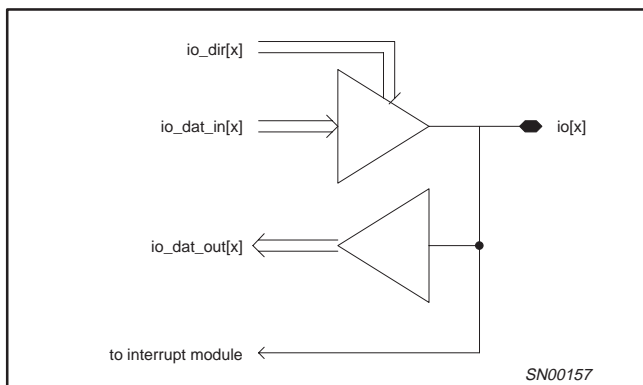

Figure 32. Block Diagram of I/O Pin Circuitry

6.9 Interrupt Generation

The UCB1100 contains a programmable interrupt control block, which can generate an interrupt for a '0' to '1' and/or a '1' to '0' transition on one or more of the $IO[0:9]$ pins, the audio and telecom clip detect, the adc_ready signal and the tsp_low and $tsmx_low$ signals.

The interrupt generation mode is set by the int_ris_ena bits in register 2 and the int_fal_ena bits in the control register 3. The actual interrupt status of each signal can be read from the control register 4. The interrupt status is clear whenever a '1' to '0' transition is written in control register 4 for the corresponding bit. The $irqout$ pin presents the 'OR' function of all interrupt status bits and can be used to give an interrupt to the system controller.

The interrupt controller is implemented asynchronously. This provide the possibly to generate interrupts when the $sibclk$ is stopped, e.g., an interrupt can be generated in power down mode, when the touch screen is pressed or when the state of one of the io pins changes.

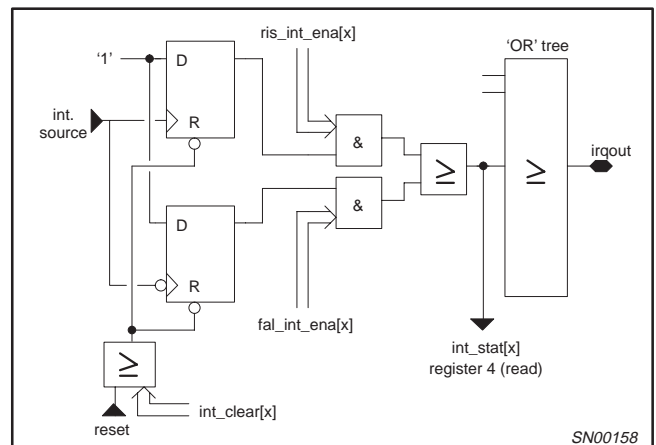

Figure 33. Block Diagram of the Interrupt Controller

Advanced modem/audio analog front-end

UCB1100

6.10 Reset Circuitry

The nreset signal is captured in the UCB1100 using an asynchronous pulse stretching circuit. The nreset signal may be pulled down when the sibclk is still stopped. The internal circuitry remembers this reset signal and generates an internal reset signal from at least 5 sibclk periods.

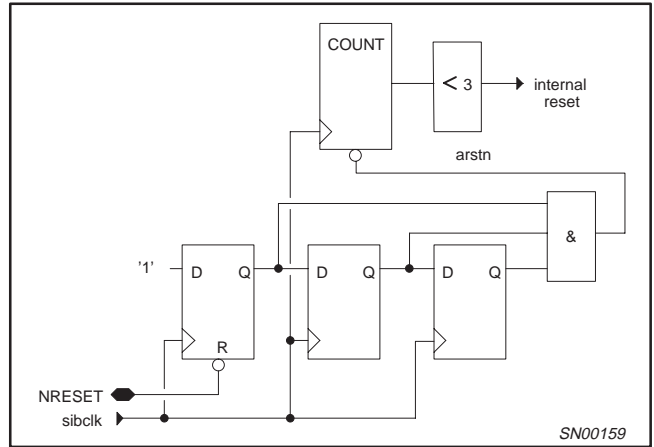

Figure 34. Block Diagram of the Reset Circuitry

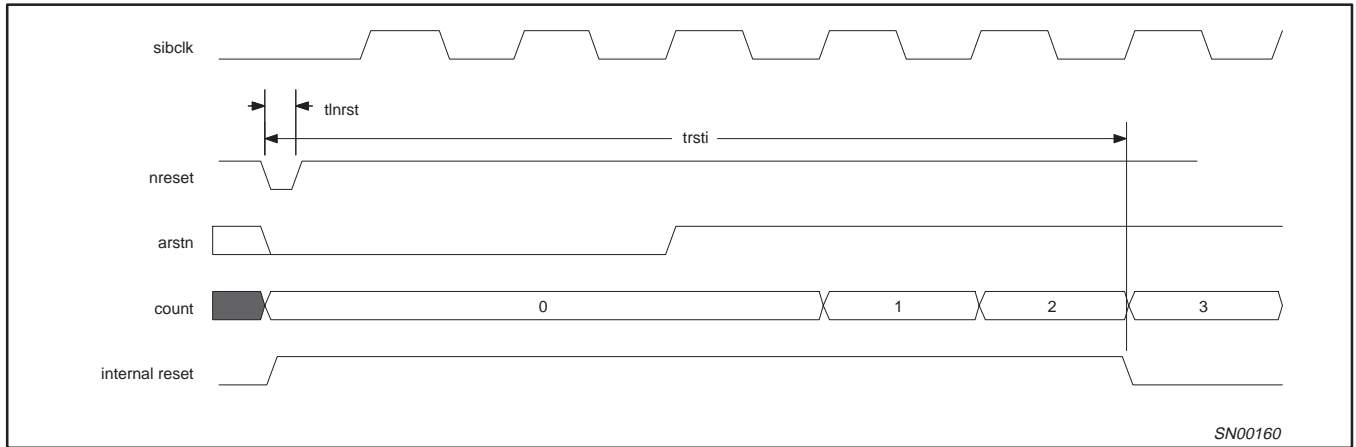

Figure 35. Timing Diagram of the Reset Circuitry

SYMBOL	PARAMETER	CONDITIONS	LIMITS			UNIT
			MIN	TYP	MAX	
t_{nrst}	nreset pulse width		5			ns
t_{rsti}	width of internal reset signal			$5 * t_{sibclk}$		ns
t_{pcrsti}	delay between rising edge sibclk and internal reset				25	ns

7.0 MISCELLANEOUS

7.1 Power Routing Strategy

The UCB1100 has nine power supply pins, since the UCB1100 contains five power supply regions within the circuit. The analogue and digital parts have their separate power supplies to reduce the interference between these parts. The speaker driver circuit is powered separately (vdda2/vssa2) from the other analogue circuit parts and the touch screen switch matrix has its own ground pin (vssa3). This separation in the analogue part reduces the interference between the speaker driver and the touch screen switch matrix, which has relatively large and fluctuating current consumption and the remaining parts of the analog.

The vssd pins and the vssa1 pin are connected within the UCB1100 circuit. It is recommended to connect the vssd pins and the vssa1 directly to a ground plane on the PCB. The split in power supply connections should be maintained on the PCB to get optimal separation. Figure 36 shows the recommended PCB power supply strategy.

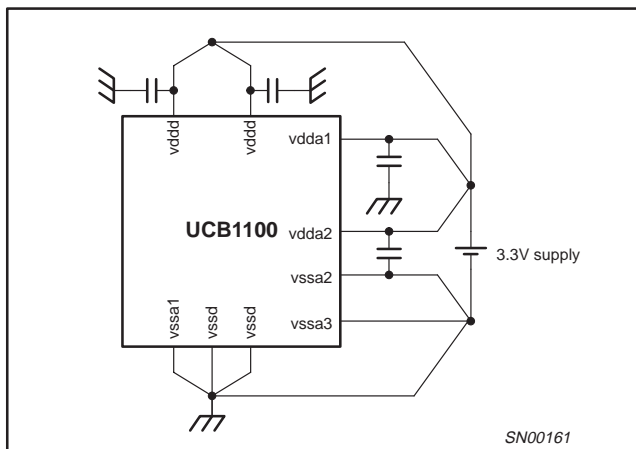

Figure 36. Recommended Power Supply Connection Strategy

Advanced modem/audio analog front-end

UCB1100

8.0 CONTROL REGISTER OVERVIEW

Address 0: IO port data register

BIT	MODE	SYMBOL	REMARK	RESET
9:0	R/W	io_data[9:0]	The bits in the write register provide the data of the io pin when programmed as output. The bits in the read register return the actual state of the associated io pin.	0

Address 1: IO port direction register

BIT	MODE	SYMBOL	REMARK	RESET
9:0	R/W	io_dir[9:0]	If '1', the associated io pin is defined as output. If '0', the associated io pin is defined as input	0
15	R/W	sib_zero	If '1', the sibdout pin is forced '0' during the second sib word. If '0', the sibdout pin tristated during the second sib word	0

Address 2: Rising edge interrupt enable register

BIT	MODE	SYMBOL	REMARK	RESET
9:0	R/W	io_ris_int[9:0]	If '1', the rising edge interrupt of the associated io pin is enabled	0
11	R/W	adc_ris_int	If '1', the rising edge interrupt of the adc_ready signal is enabled	0
12	R/W	tspx_ris_int	If '1', the rising edge interrupt of the tspx signal is enabled	0
13	R/W	tsmx_ris_int	If '1', the rising edge interrupt of the tsmx signal is enabled	0
14	R/W	tclip_ris_int	If '1', the rising edge interrupt of the telecom clip is enabled	0
15	R/W	aclip_ris_int	If '1', the rising edge interrupt of the audio clip is enabled	0

Address 3: Falling edge interrupt enable register

BIT	MODE	SYMBOL	REMARK	RESET
9:0	R/W	io_fal_int[9:0]	If '1', the falling edge interrupt of the associated io pin is enabled	0
11	R/W	adc_fal_int	If '1', the falling edge interrupt of the adc_ready signal is enabled	0
12	R/W	tspx_fal_int	If '1', the falling edge interrupt of the tspx signal is enabled	0
13	R/W	tsmx_fal_int	If '1', the falling edge interrupt of the tsmx signal is enabled	0
14	R/W	tclip_fal_int	If '1', the falling edge interrupt of the telecom clip is enabled	0
15	R/W	aclip_fal_int	If '1', the falling edge interrupt of the audio clip is enabled	0

Address 4: Interrupt clear/status register

BIT	MODE	SYMBOL	REMARK	RESET
9:0	W	io_int_clr[0:9]	A '0' to '1' transition clears the interrupt of the associate io pin	0
	R	io_int_stat[9:0]	Returns the actual interrupt status of the associated io pin	
11	W	adc_int_clr	A '0' to '1' transition clears the interrupt adc_ready signal	0
	R	adc_int_stat	Returns the actual interrupt status of the adc_ready signal	
12	W	tspx_int_clr	A '0' to '1' transition clears the interrupt of the tspx signal	0
	R	tspx_int_stat	Returns the actual interrupt status of the tspx signal	
13	W	tsmx_int_clr	A '0' to '1' transition clears the interrupt of the tsmx signal	0
	R	tsmx_int_stat	Returns the actual interrupt status of the tsmx signal	
14	W	tclip_int_clr	A '0' to '1' transition clears the interrupt of the telecom clip	0
	R	tclip_int_stat	Returns the actual interrupt status of the telecom clip	
15	W	aclip_int_clr	A '0' to '1' transition clears the interrupt of the audio clip	0
	R	aclip_int_stat	Returns the actual interrupt status of the audio clip	

Advanced modem/audio analog front-end

UCB1100

Address 5: Telecom control register A

BIT	MODE	SYMBOL	REMARK	RESET
6:0	R/W	tel_div[6:0]	Telecom codec sample rate divisor. Valid values are between [0010000] (=16) and [1111111] (=127)	16
7	R/W	tel_loop_ena	If '1', the loopback mode of within the telecom codec is enabled.	0

Address 6: Telecom control register B

BIT	MODE	SYMBOL	REMARK	RESET
3	R/W	high_pass_ena]	If '1', the voice band filter in the telecom input path is enabled	0
4	R	tel_clip	The bit returns the actual telecom clip detection status.	
	W	tel_clip	A '0' to '1' transition bit clears the telecom clip detection status	0
6	R/W	tel_att	If '1', the telecom input attenuation (6dB) is enabled.	0
11	R/W	side_sup_ena	If '1', the sidetone suppression circuit is activated	0
13	R/W	tel_mute	If '1', the telecom output is muted	0
14	R/W	tel_in_ena	If '1', the telecom input path is activated	0
15	R/W	tel_out_ena	If '1', the telecom output path is activated	0

Address 7: Audio control register A

BIT	MODE	SYMBOL	REMARK	RESET
6:0	R/W	aud_div[6:0]	Audio codec sample rate divisor. Valid values lie between [00000110] (=6) and [1111111] (=127).	6
11:7	R/W	aud_gain[4:0]	Audio input gain setting. Values range from [00000] (no gain) to [11111] (46.5dB gain)	0

Address 8: Audio control register B

BIT	MODE	SYMBOL	REMARK	RESET
4:0	R/W	aud_att[4:0]	Audio output attenuation setting. Values range from [00000] (no attenuation) to [11111] (69dB attenuation).	0
6	R/W	aud_clip_ena	If '1', the audio clip detection circuitry is activated	0
8	R/W	aud_loop	If '1', the loopback mode in the audio codec is activated.	0
13	R/W	aud_mute	If '1', the audio output is muted	0
14	R/W	aud_in_ena	If '1', the audio codec input path is activated.	0
15	R/W	aud_out_ena	If '1', the audio codec output path is activated.	0

Advanced modem/audio analog front-end

UCB1100

Address 9: Touch screen control register

BIT	MODE	SYMBOL	REMARK	RESET
0	R/W	tspx_pow	If '1', the tspx pin is powered	0
1	R/W	tsmx_pow	If '1', the tsmx pin is powered	0
2	R/W	tspy_pow	If '1', the tspy pin is powered	0
3	R/W	tsmy_pow	If '1', the tspy pin is powered	0
4	R/W	tspx_gnd	If '1', the tspx pin is grounded	0
5	R/W	tsmx_gnd	If '1', the tsmx pin is grounded	0
6	R/W	tspy_gnd	If '1', the tspy pin is grounded	0
7	R/W	tsmy_gnd	If '1', the tspy pin is grounded	0
[9:8]	R/W	tsc_mode[1:0]	Touch screen operation mode 00 : interrupt mode 01 : pressure measurement mode 1x : position measurement mode	0
11	R/W	tsc_bias_ena	If '1', the touch screen bias circuitry is activated.	0
12	R/W	tspx_state	This bit returns the inverted state of the tspx pin, '0' is high voltage (pen up), '1' is low voltage (pen down)	
13	R/W	tsmx_state	This bit returns the inverted state of the tsmx pin, '0' is high voltage (pen up), '1' is low voltage (pen down)	

Address 10: ADC control register

BIT	MODE	SYMBOL	REMARK	RESET
0	R/W	adc_sync_ena	If '1', the adc sync mode is activated	0
1	R/W	vrefbyp_con	If '1', the internal reference voltage is connected to the vrefbyp pin.	0
4:2	R/W	adc_input[2:0]	ADC input selection bits: 000: tspx 001: tsmx 010: tspy 011: tsmy 100: ad0 101: ad1 110: ad2 111: ad3	0
5	R/W	ext_ref_ena	If '1', an external reference voltage has to be applied to the vrefbyp pin	0
7	R/W	adc_start	A '0' to '1' transition starts the adc conversion sequence.	0
15	R/W	adc_ena	If '1', the adc circuit is activated	0

Address 11: ADC data register

BIT	MODE	SYMBOL	REMARK	RESET
14:5	R	adc_data[9:0]	Returns the ADC result	0
15	R	adc_dat_val	Returns '0' if an adc conversion is in progress. Returns '1' if the 0 adc conversion is completed and the adc data is stored in the adc_data[9:0] register.	0

Address 12: ID register

BIT	MODE	SYMBOL	REMARK	RESET
5:0	R	version[5:0]	Returns 000011 for all the UCB1100 circuits meeting this specification.	
11:6	R	device[5:0]	Returns 000000 for all the UCB1100 circuits meeting this specification.	
15:12	R	supplier[3:0]	Returns 0001 for all the UCB1100 circuits meeting this specification.	

Advanced modem/audio analog front-end

UCB1100

Address 13: Mode register

BIT	MODE	SYMBOL	REMARK	RESET
0	R/W	aud_test	If '1', the analogue audio test mode is activated (Note 1)	0
1	R/W	tel_test	If '1', the analogue telecom test mode is activated (Note 1)	0
5–2	R/W	prod_test_mode	These bits select the build in production test modes (Note 1)	0
12	R/W	dyn_vflag_ena	If '1', the dynamic data valid flag mode is activated for both the audio and the telecom data valid flag.	0
13	R/W	aud_off_can	If '1', the offset cancelling circuit in the audio input path is disabled.	0
14	R/W		Reserved bit for special function	
15	R/W		Reserved bit for special function	

NOTES:

1. These bits can only be written if the test pin is '1'.
2. The functionality of the UCB1100 is changed when one or more test modes are activated.

Address 14: Reserved

BIT	MODE	SYMBOL	REMARK	RESET
			This register is reserved for future use.	

Address 15: Null register

BIT	MODE	SYMBOL	REMARK	RESET
15:0	R		Returns [1111111111111111] at all times	

Advanced modem/audio analog front-end

UCB1100

9.0 PACKAGE OUTLINES

9.1 LQFP48

LQFP48: plastic low profile quad flat package; 48 leads; body 7 x 7 x 1.4 mm

SOT313-2

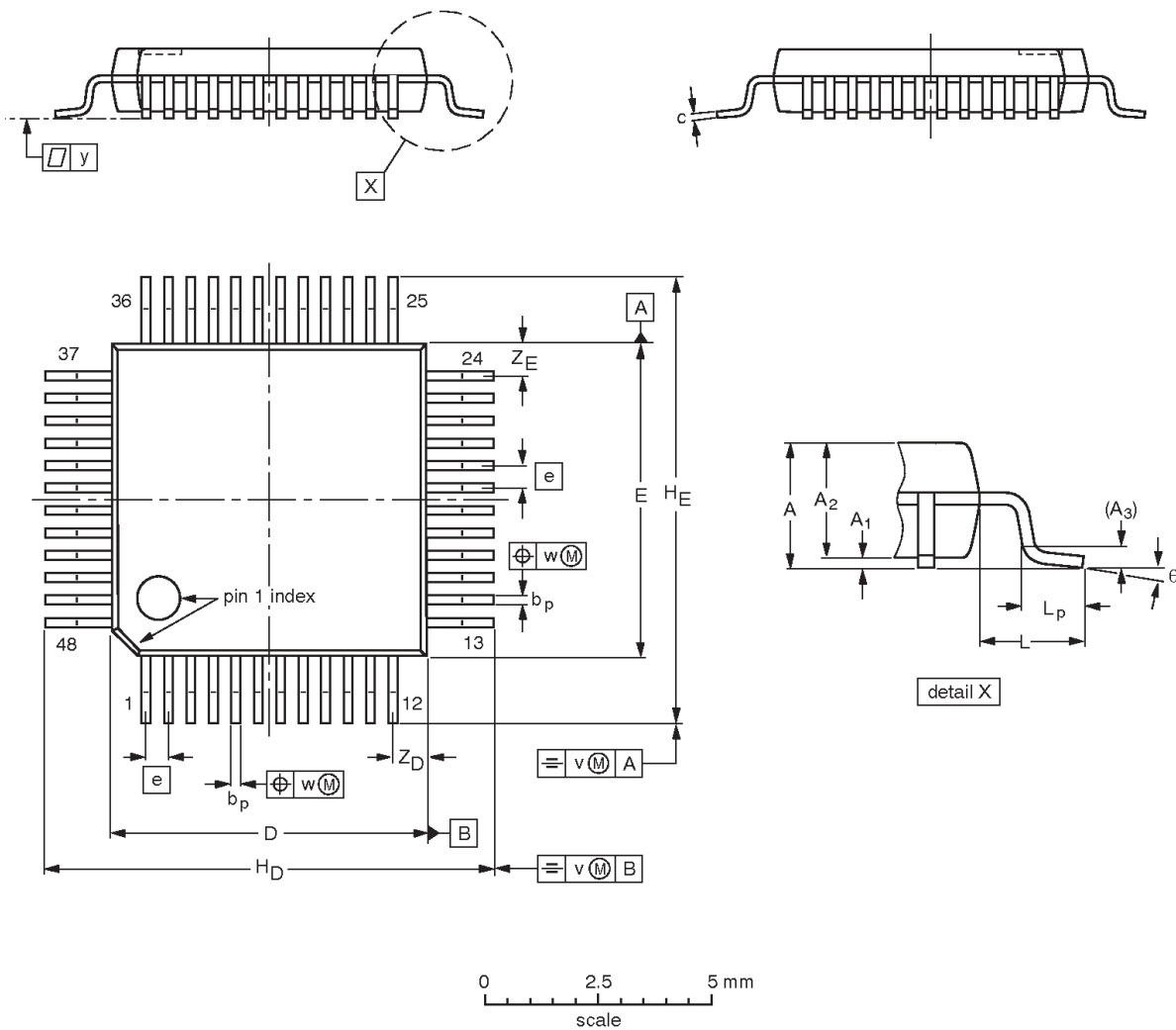

DIMENSIONS (mm are the original dimensions)

UNIT	A max.	A ₁	A ₂	A ₃	b _p	c	D ⁽¹⁾	E ⁽¹⁾	e	H _D	H _E	L	L _p	v	w	y	Z _D ⁽¹⁾	Z _E ⁽¹⁾	θ
mm	1.60	0.20 0.05	1.45 1.35	0.25	0.27 0.17	0.18 0.12	7.1 6.9	7.1 6.9	0.5	9.15 8.85	9.15 8.85	1.0	0.75 0.45	0.2	0.12	0.1	0.95 0.55	0.95 0.55	7° 0°

Note

1. Plastic or metal protrusions of 0.25 mm maximum per side are not included.

OUTLINE VERSION	REFERENCES				EUROPEAN PROJECTION	ISSUE DATE
	IEC	JEDEC	EIAJ			
SOT313-2						94-12-19 97-08-01

Advanced modem/audio analog front-end

UCB1100

NOTES

Advanced modem/audio analog front-end

UCB1100

10.0 DEFINITIONS

Data sheet status

Data sheet status	Product status	Definition [1]
Objective specification	Development	This data sheet contains the design target or goal specifications for product development. Specification may change in any manner without notice.
Preliminary specification	Qualification	This data sheet contains preliminary data, and supplementary data will be published at a later date. Philips Semiconductors reserves the right to make changes at any time without notice in order to improve design and supply the best possible product.
Product specification	Production	This data sheet contains final specifications. Philips Semiconductors reserves the right to make changes at any time without notice in order to improve design and supply the best possible product.

[1] Please consult the most recently issued datasheet before initiating or completing a design.

Definitions

Short-form specification — The data in a short-form specification is extracted from a full data sheet with the same type number and title. For detailed information see the relevant data sheet or data handbook.

Limiting values definition — Limiting values given are in accordance with the Absolute Maximum Rating System (IEC 134). Stress above one or more of the limiting values may cause permanent damage to the device. These are stress ratings only and operation of the device at these or at any other conditions above those given in the Characteristics sections of the specification is not implied. Exposure to limiting values for extended periods may affect device reliability.

Application information — Applications that are described herein for any of these products are for illustrative purposes only. Philips Semiconductors make no representation or warranty that such applications will be suitable for the specified use without further testing or modification.

Disclaimers

Life support — These products are not designed for use in life support appliances, devices or systems where malfunction of these products can reasonably be expected to result in personal injury. Philips Semiconductors customers using or selling these products for use in such applications do so at their own risk and agree to fully indemnify Philips Semiconductors for any damages resulting from such application.

Right to make changes — Philips Semiconductors reserves the right to make changes, without notice, in the products, including circuits, standard cells, and/or software, described or contained herein in order to improve design and/or performance. Philips Semiconductors assumes no responsibility or liability for the use of any of these products, conveys no license or title under any patent, copyright, or mask work right to these products, and makes no representations or warranties that these products are free from patent, copyright, or mask work right infringement, unless otherwise specified.

Philips Semiconductors
811 East Arques Avenue
P.O. Box 3409
Sunnyvale, California 94088-3409
Telephone 800-234-7381

© Copyright Philips Electronics North America Corporation 1998
All rights reserved. Printed in U.S.A.

Date of release: 05-98

Document order number:

9397 750 03868

Let's make things better.

SUNSTAR 商斯达实业集团是集研发、生产、工程、销售、代理经销、技术咨询、信息服务等为一体的高科技企业，是专业高科技电子产品生产厂家，是具有 10 多年历史的专业电子元器件供应商，是中国最早和最大的仓储式连锁规模经营大型综合电子零部件代理分销商之一，是一家专业代理和分销世界各大品牌 IC 芯片和电子元器件的连锁经营综合性国际公司，专业经营进口、国产名厂名牌电子元件，型号、种类齐全。在香港、北京、深圳、上海、西安、成都等全国主要电子市场设有直属分公司和产品展示展销窗口门市部专卖店及代理分销商，已在全国范围内建成强大统一的供货和代理分销网络。我们专业代理经销、开发生产电子元器件、集成电路、传感器、微波光电元器件、工控机/DOC/DOM 电子盘、专用电路、单片机开发、MCU/DSP/ARM/FPGA 软件硬件、二极管、三极管、模块等，是您可靠的一站式现货配套供应商、方案提供商、部件功能模块开发配套商。商斯达实业公司拥有庞大的资料库，有数位毕业于著名高校——有中国电子工业摇篮之称的西安电子科技大学（西军电）并长期从事国防尖端科技研究的高级工程师为您精挑细选、量身订做各种高科技电子元器件，并解决各种技术问题。

微波光电部专业代理经销高频、微波、光纤、光电元器件、组件、部件、模块、整机；电磁兼容元器件、材料、设备；微波 CAD、EDA 软件、开发测试仿真工具；微波、光纤仪器仪表。欢迎国外高科技微波、光纤厂商将优秀产品介绍到中国、共同开拓市场。长期大量现货专业批发高频、微波、卫星、光纤、电视、CATV 器件：晶振、VCO、连接器、PIN 开关、变容二极管、开关二极管、低噪晶体管、功率电阻及电容、放大器、功率管、MMIC、混频器、耦合器、功分器、振荡器、合成器、衰减器、滤波器、隔离器、环行器、移相器、调制解调器；光电子元件和组件：红外发射管、红外接收管、光电开关、光敏管、发光二极管和发光二极管组件、半导体激光二极管和激光器组件、光电探测器和光接收组件、光发射接收模块、光纤激光器和光放大器、光调制器、光开关、DWDM 用光发射和接收器件、用户接入系统光收发器件与模块、光纤连接器、光纤跳线/尾纤、光衰减器、光纤适配器、光隔离器、光耦合器、光环行器、光复用器/转换器；无线收发芯片和模组、蓝牙芯片和模组。

更多产品请看本公司产品专用销售网站：

商斯达中国传感器科技信息网：<http://www.sensor-ic.com/>

商斯达工控安防网：<http://www.pc-ps.net/>

商斯达电子元器件网：<http://www.sunstare.com/>

商斯达微波光电产品网：[HTTP://www.rfoe.net/](http://www.rfoe.net/)

商斯达消费电子产品网：<http://www.icasic.com/>

商斯达实业科技产品网：<http://www.sunstars.cn/> 微波元器件销售热线：

地址：深圳市福田区福华路福庆街鸿图大厦 1602 室

电话：0755-82884100 83397033 83396822 83398585

传真：0755-83376182 (0) 13823648918 MSN: SUNS8888@hotmail.com

邮编：518033 E-mail:szss20@163.com QQ: 195847376

深圳赛格展销部：深圳华强北路赛格电子市场 2583 号 电话：0755-83665529 25059422

技术支持：0755-83394033 13501568376

欢迎索取免费详细资料、设计指南和光盘；产品凡多，未能尽录，欢迎来电查询。

北京分公司：北京海淀区知春路 132 号中发电子大厦 3097 号

TEL: 010-81159046 82615020 13501189838 FAX: 010-62543996

上海分公司：上海市北京东路 668 号上海赛格电子市场 D125 号

TEL: 021-28311762 56703037 13701955389 FAX: 021-56703037

西安分公司：西安高新开发区 20 所(中国电子科技集团导航技术研究所)

西安劳动南路 88 号电子商城二楼 D23 号

TEL: 029-81022619 13072977981 FAX:029-88789382