

3 POWER AMPLIFIER DESIGN

3.1 Classes of operation and biasing

3.1.1 Class-A

Class-A operation is characterized by a constant DC collector (or drain) voltage and current. This class of operation is required for linear amplifiers with severe linearity requirements including:

- Drivers in SSB transmitters where a 2-tone 3rd-order intermodulation of at least -40 dB is required
- Drivers in TV transmitters where the contribution to the gain compression must be very low, i.e. not more than a few tenths of a dB
- All stages of TV transposers. These are tested with a 3-tone signal and the 3rd-order intermodulation products must be below -55 to -60 dB. The driver stages should only deliver a small contribution to the overall intermodulation, so they have to operate at even lower efficiency than the final stage (as this is the only way to reduce distortion in class-A).

Though the theoretical maximum efficiency of a class-A amplifier is 50%, because of linearity requirements, the efficiency in the first two applications listed above will be no more than about 25%. And in TV transposers, the efficiency is only about 15% for the final stage and even less for the driver stages.

The transistor power gain in a class-A amplifier is about 3 to 4 dB higher than that of the same transistor operating in class-B. This is because the conduction period of the drain current in class-A is 360° and in class-B only 180° (electrical degrees). Therefore, the effective trans-conductance in class-B is only half that in class-A.

3.1.1.1 DISTORTION

SSB modulation is mainly used in the HF range: 1.5 to 30 MHz. When testing transistors for this application, Philips uses a standard test frequency of 28 MHz. Owing to its variable amplitude, an SSB signal is sensitive to distortion.

3.1.1.1.1 2-TONE INTERMODULATION DISTORTION TEST

3rd and 5th-order products

This is the most common distortion test. In this test, two equal-amplitude tones 1 kHz apart are applied to the input of the amplifier under test. Practical amplifiers will never be completely linear, and the most important distortion products they produce are the 3rd and 5th order ones, because these are in or very near to the pass-band.

NOTE TO SECTION 3

For clarity in equations, identifiers such as R_1 , $+jB_2$, $-jX_3$ in drawings are written as R_1 , $+jB_2$, $-jX_3$ in the body text.

If the frequencies of the two input tones are denoted by p and q , the 3rd-order products are at frequencies of $2p-q$ and $2q-p$, see Fig.3-1. The 5th-order products which usually have smaller amplitudes are at $3p-2q$ and $3q-2p$. Note, the two intermodulation products of the same order don't necessarily have equal amplitudes. This can be due to non-ideal decoupling of the supply voltages, i.e. decoupling that is insufficiently effective at all the frequencies involved. Philips publishes the largest value in data sheets.

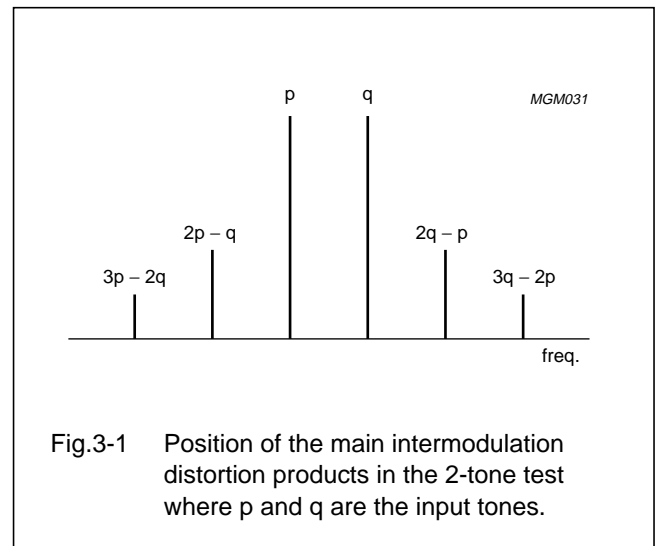

Fig.3-1 Position of the main intermodulation distortion products in the 2-tone test where p and q are the input tones.

Power relationships

If the tones at p and q are each of 10 W, then the combination has an average (calorific) power of 20 W. The two tones can however combine in phase or out of phase, producing an RF signal of variable amplitude. When the two tones are in phase, the voltage amplitude is twice that of one tone, so the power is four times that of one tone (in this example: 40 W). This maximum power is called the peak envelope power (PEP) and is commonly published in data sheets. When the two tones are in anti-phase, their combined amplitude is zero. In the ideal case, i.e. with no distortion, the envelope of the combined signal consists of half sine waves, see Fig.3-2.

RF transmitting transistor and power amplifier fundamentals

Power amplifier design

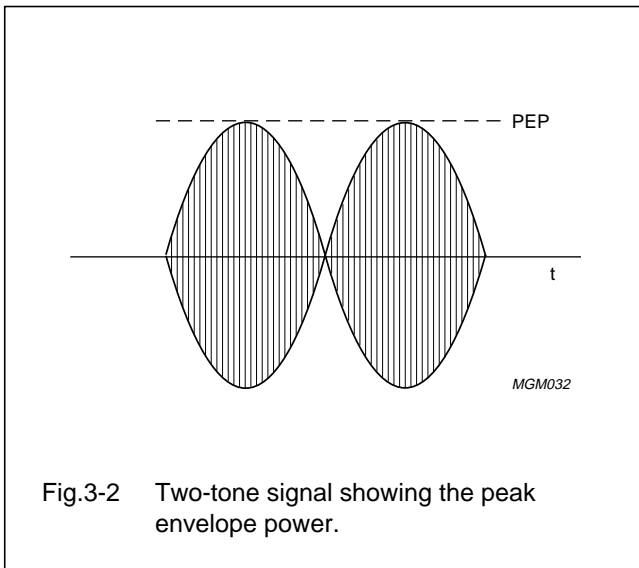

Fig.3-2 Two-tone signal showing the peak envelope power.

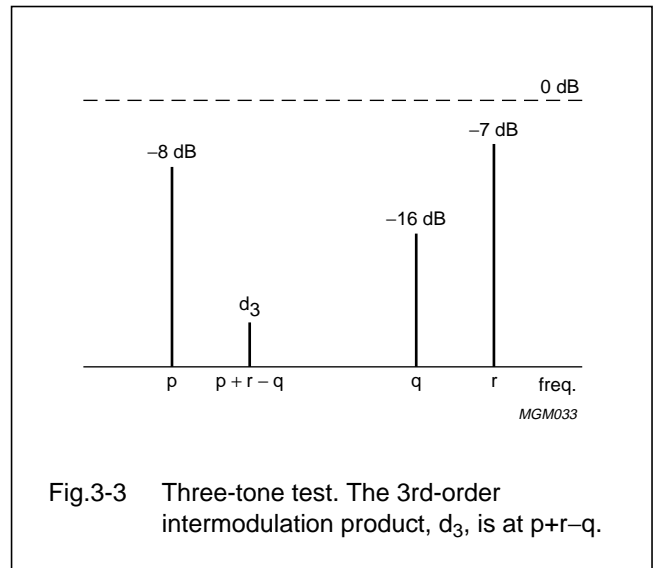

Fig.3-3 Three-tone test. The 3rd-order intermodulation product, d_3 , is at $p+r-q$.

In class-A applications, distortion products are nearly always specified relative to the amplitude of one of the input test tones. As a general guideline, in the linear region of a class-A amplifier, every 1 dB reduction of output power reduces 3rd-order intermodulation distortion by 2 dB.

3.1.1.1.2 3-TONE TEST FOR TV TRANSPOSER APPLICATIONS

In a TV transposer, vision and sound are amplified together, so the distortion requirements are more severe, and it is usual to measure intermodulation using a 3-tone signal. The most popular test (DIN 45004B, para.6.3: 3-tone uses tones of -8 dB, -16 dB and -7 dB with respect to a 0 dB reference power level called the peak sync power. The first tone (-8 dB) represents the vision carrier, the second (-16 dB) a sideband, e.g. the colour carrier, and the third (-7 dB) the sound carrier. This combination of tones has a real peak power which is very close to the 0 dB level, namely: +0.02844 dB or +0.66%.

Another important relationship is the ratio of the average power to the 0 dB level. This ratio is 0.3831, so the 0 dB level is found by multiplying the calorific power by 2.61.

In the 3-tone test, the frequency of the -7 dB tone is 5.5 MHz higher than that of the -8 dB tone, while the frequency of the -16 dB tone is varied between the other two to produce the most intermodulation. If the frequencies of the tones are denoted by p , q and r respectively, we are primarily interested in the 3rd-order intermodulation product $p+r-q$ which is inside the passband and which, in addition, usually has the largest amplitude, see Fig.3-3.

The test requirement for this product for a *complete* transposer is -51 dB with respect to the 0 dB reference level. This implies that the requirements for final stages are more severe (typically -55 dB) while those for driver stages more severe still (typically -60 dB).

In another 3-tone test method, the amplitude of the audio carrier is reduced from -7 dB to -10 dB. This has several effects:

- The actual peak power is only 76.2% of the 0 dB level
- The calorific power is 28.36% of the 0 dB level
- The intermodulation requirements are more severe. Because one of the tones is reduced by 3 dB, the intermodulation product at f_{p+r-q} is also reduced by 3 dB provided the amplifier is operating in the linear region.

3.1.1.1.3 RELATIONSHIP BETWEEN 2- AND 3-TONE TEST RESULTS

Theoretically, the first-mentioned 3-tone test and the 2-tone test measurement of SSB amplifiers are related. When (but only when) the PEP of the 2-tone test and the 0 dB level of the 3-tone test are equal, there is always a 13 dB difference in the intermodulation distortion. For example, if, an intermodulation of -40 dB is measured in the 2-tone test, -53 dB will be measured in the 3-tone test. Further, the 2-tone intermodulation should be measured relative to the two equal-amplitude tones and the 3-tone intermodulation relative to the 0 dB level.

Class-A amplifiers for TV transposers and transmitters behave in a similar way to those for SSB driver stages. So, reducing the output power by 1 dB reduces 3rd-order intermodulation by 2 dB.

RF transmitting transistor and power amplifier fundamentals

Power amplifier design

3.1.1.2 BIASING

For MOS transistors, biasing is very simple. The temperature coefficient of the I_D versus V_{GS} curve is almost zero at the optimum operating point so an adjustable resistive divider is sufficient. For bipolar transistors, the situation is more complicated because of the temperature dependency of h_{FE} and V_{BE} .

In an audio amplifier, it is usual to stabilize the operating point by means of an emitter resistor and a base potentiometer. In an RF amplifier, however, it is preferable to ground the emitter to obtain maximum power gain as illustrated in Fig.3-4.

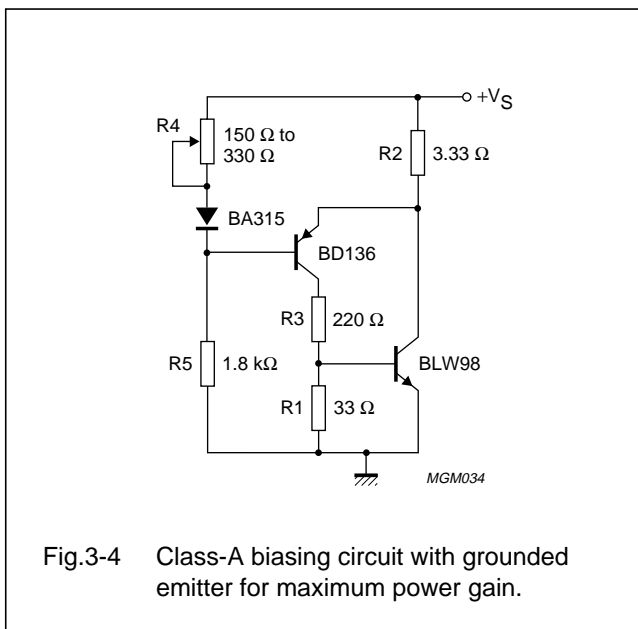

Fig.3-4 Class-A biasing circuit with grounded emitter for maximum power gain.

3.1.1.2.1 DESIGN EXAMPLE

In this example, a bias circuit must be designed such that the BLW98 RF transistor operates at $V_{CE} = 25\text{ V}$ and $I_C = 850\text{ mA}$. The auxiliary transistor is a small PNP audio power transistor: BD136. Owing to the large negative feedback in the final circuit (Fig.3-4), the operating point of the BLW98 is extremely well stabilized for variations in ambient temperature and for the h_{FE} spread of the BLW98.

For instance, if h_{FE} rises due to an increase in ambient temperature, the collector voltage of the BLW98 will fall slightly, causing a decrease in the collector current of the BD136 and therefore in the base current of the BLW98.

The BA315 diode is used to compensate the temperature coefficient of the V_{BE} of the BD136. The variable resistor in series with this diode serves to adjust the I_C of the BLW98 accurately at the desired value.

3.1.1.2.2 CALCULATION OF COMPONENT VALUES

BD136 collector current

The supply voltage is chosen 2 to 3 V higher than the V_{CE} of the BLW98, e.g. 28 V (to provide sufficient negative feedback). The h_{FE} of the BLW98 can vary from 15 to about 100. To reduce the I_C variation of the BD136, the BLW98 is pre-loaded with a resistor between base and emitter (R_1 in Fig.3-4). The I_B of the BLW98 can vary from 8.5 to 57 mA while the required V_{BE} for an I_C of 850 mA is about 0.98 V. If 30 mA flows through R_1 , the required resistance is: $0.98/0.03 \sim 33\ \Omega$.

The I_C of the BD136 can now range from 38.5 to 87 mA with an average value of 51 mA. The BD136 has a typical h_{FE} of 100, so its I_B is approximately 0.5 mA and its average emitter current is 51.5 mA. The current through the collector resistor, R_2 , of the BLW98 is then: $0.85 + 0.0515 = 0.9015\text{ A}$. For a voltage drop of 3 V ($28 - 25\text{ V}$), a 3.33 Ω resistor ($3/0.9015$) rated at a rather high 2.7 W (3×0.9015) is required.

Protection resistor

To protect the BLW98 and to reduce the dissipation in the BD136, a resistor, R_3 , is included between the collector of the BD136 and the base of the BLW98. The value of R_3 must be calculated on the basis of the minimum h_{FE} of the BLW98, and thus on the maximum I_C of the BD136 of 87 mA. As the V_{BE} of the BLW98 is about 1 V and the $V_{CE(sat)}$ of the BD136 is less than 1 V, the maximum voltage drop across R_3 must be less than 23 V. This means a maximum value of: $23/0.087 = 264\ \Omega$, say 220 Ω , and the maximum dissipation in R_3 is $0.087^2 \times 220 = 1.67\text{ W}$.

Base potentiometer

Finally, the BD136 base potentiometer components (R_4 , R_5 and the BA315) have to be determined. The potentiometer current must be high compared with the I_B of the BD136 (say 10 to 20 I_B); 13 mA is suitable and corresponds with the test circuit in the data sheet. As the V_{BE} of the BD136 is about 0.7 V and the voltage drop across the BA315 diode is 0.8 V, there is a drop of 2.9 V across the variable resistor, so a nominal resistance of $2.9/0.013 = 223\ \Omega$ is required. A range of 150 to 330 Ω provides sufficient adjustment for practical use. Across resistor R_5 , there is a voltage drop of 24.3 V and a current of 13.5 mA, so a resistance of $24.3/0.0135 = 1.8\text{ k}\Omega$ is required.

Note, unlike some types of bias circuit, this type does not suffer from parasitic oscillations due to high loop gain.

RF transmitting transistor and power amplifier fundamentals

Power amplifier design

3.1.2 Class-AB

Class-AB operation is characterized by a constant collector voltage and (unlike class-A) a quiescent collector current that increases with drive power. The distortion behaviour is also different to that of class-A. Class-AB operation is used for linear amplifiers with less severe requirements including:

- Final stages of SSB transmitters where a 2-tone 3rd-order intermodulation of about –30 dB is required
- Final stages of TV transmitters where a gain compression of max. 1 dB is required
- Final stages of base stations for cellular radio.

Maximum efficiency is obtained at maximum power, and although the theoretical maximum efficiency of a class-AB amplifier is 78.5%, in practice it is always lower because:

- There are resistive losses both in the transistor and in the output matching circuit
- The collector AC voltage cannot be driven to its maximum value because of distortion requirements
- There is a small quiescent current (for a bipolar transistor, about 2% of the collector current at maximum power and, for a MOSFET, about 12% of the drain current at maximum power).

For HF and VHF amplifiers, in a 2-tone situation, the average efficiency is about 40% which corresponds to an efficiency of 60 to 65% at maximum power (PEP situation). At higher frequencies, the efficiencies are somewhat lower. The power gain of a class-AB amplifier is between those of class-A and class-B amplifiers.

3.1.2.1 DISTORTION

Unlike a class-A amplifier where intermodulation improves as the power is reduced, for a class-AB amplifier, the distortion is as shown in Fig.3-5.

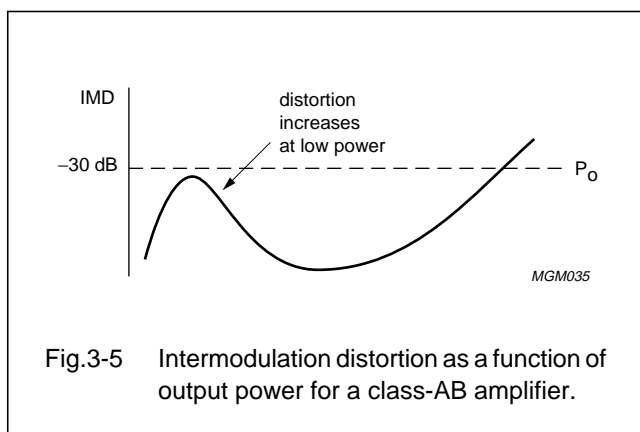

The increasing distortion at low powers is due to 'cross-over' distortion, i.e., distortion during the transition from class-A to class-B operation.

3.1.2.1.1 EFFECT OF LOAD IMPEDANCE

An important factor affecting distortion is the load impedance. The optimum value at the fundamental frequency is always specified in Philips' transistor data sheets for the frequency range of interest. The load reactance at the second harmonic is also important. Often, this is solely the output capacitance of the transistor. The collector or drain current contains a substantial second harmonic component which due to the presence of the load reactance causes a second harmonic output voltage component. A relatively small component can be tolerated. However, if it is above say 10% of the voltage at the fundamental frequency, the amplifier will saturate at a lower power than intended, so the allowable distortion is reached at lower power.

This can be solved by adding an external capacitor between collector (or drain) and earth. Though this will reduce gain and efficiency somewhat, it will reduce intermodulation significantly. A good practical rule is that the reactance of the parallel combination of internal and external capacitance at the second harmonic should be about 2.2 times the load resistance at the fundamental frequency. For wideband amplifiers, there is another solution which can be found in application reports, e.g. "NCO8703".

3.1.2.2 BIASING

For MOS transistors, biasing is rather easy. In most cases, a resistive voltage divider is sufficient. If necessary, a diode or an NTC thermistor can be included in the lower branch to compensate for the negative t.c. of the gate voltage.

For bipolar transistors, a more sophisticated circuit is required. The circuit has to deliver a constant voltage of about 0.7 V (adjustable over a restricted range) and should have very low internal resistance. The latter is required to accommodate a wide range of 'load' currents (i.e. base drive currents for the RF transistor), whilst maintaining a nearly constant output voltage. Other desired properties are temperature compensation and the lowest possible current consumption. Figure 3-6 shows a circuit meeting these requirements.

The bias circuit has large negative feedback. If the load current increases, the output voltage drops slightly, decreasing the collector current of the BD135 whose collector voltage increases to counteract the drop in output voltage.

RF transmitting transistor and power amplifier fundamentals

Power amplifier design

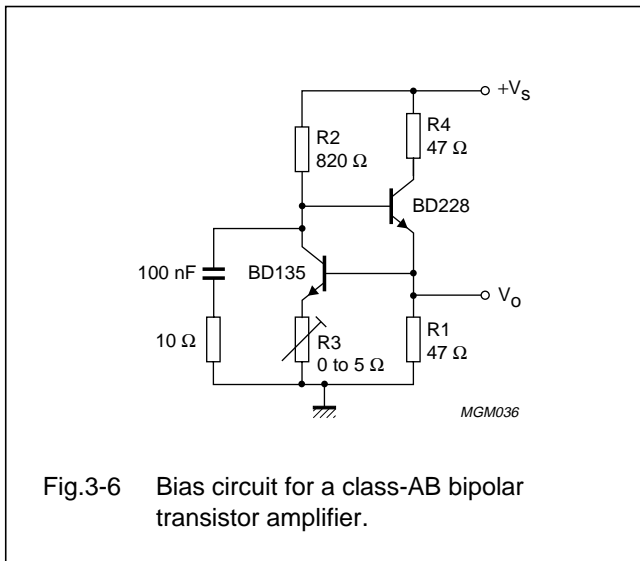

Fig.3-6 Bias circuit for a class-AB bipolar transistor amplifier.

3.1.2.2.1 DESIGN EXAMPLE

Calculation of component values

BD228 BASE AND COLLECTOR CURRENT

In this example, it is assumed that the bias circuit is for an amplifier delivering an output power of 100 W at a supply voltage of 28 V. So, if the minimum amplifier efficiency is 50%, the required DC input power is 200 W, corresponding to a collector current of 7.14 A. If the transistors used have a minimum h_{FE} of 15, the maximum base current can be 0.48 A. Such an amplifier could be the final stage of an SSB transmitter where the output power and therefore also the base current vary from almost zero to 0.48 A. In the bias circuit, a pre-loading resistor, R_1 , is used to reduce the base current variations. To draw 15 mA at 0.7 V, R_1 must be $0.7/0.015 = 47 \Omega$. The maximum emitter current of the BD228 will then be nearly 0.5 A. From the published h_{FE} data for this type, the base current is 15 mA maximum.

The current through the collector resistor, R_2 , of the BD135 is chosen to be twice this value, i.e. 30 mA, to restrict the variations in the collector current of the BD135. The V_{BE} of the BD228 is about 0.8 V, so the voltage across R_2 is 26.5 V, giving a value of: $26.5/0.03 = 883 \Omega$ (nearest preferred value: 820 Ω , 1 W.)

OUTPUT VOLTAGE

At first sight, the choice of a BD135 in this circuit seems a bit overspecified for a transistor that has to draw only 30 mA. Yet this has been done deliberately because then the V_{BE} required by the BD135 is low (smaller than the bias voltage to be delivered to the RF amplifier.) The difference

is corrected by the variable resistor, R_3 , in the emitter of the BD135. The output voltage of the bias circuit, and thus the quiescent current of the RF amplifier, can now be adjusted. With a resistor of 5 Ω max., the output voltage can be adjusted by at least 100 mV, sufficient for this application.

PROTECTION RESISTOR

To protect the BD228 against the consequences of a short-circuit of the output voltage, it is advisable to include a resistor, R_4 , in the collector lead. As the BD228 has a $V_{CE(sat)}$ of 0.8 V max., a voltage drop of 26.5 V across R_4 is allowed at the maximum collector current of 0.5 A. The maximum value of this resistor is therefore $26.5/0.5 = 53 \Omega$ (nearest preferred value: 47 Ω .) Note that R_4 must be rated at 12 W ($I^2R = 0.5^2 \times 47 = 11.75$).

PERFORMANCE

The internal resistance of this bias circuit is exceptionally small. Values of less than 0.1 Ω have been measured, so the output voltage varies by less than 50 mV from zero to full load. The value of the output voltage is mainly determined by the V_{BE} of the BD135, which has a well-known temperature dependence (about $-2 \text{ mV}/^\circ\text{C}$), providing reasonable matching with the required V_{BE} of RF transistors without any special measures.

This type of bias circuit can develop parasitic oscillations near 1 MHz with highly capacitive loads (such as the supply decoupling capacitors in the RF circuit). This can be prevented by an RC combination between the collector of the BD135 and ground. Good values are 10 Ω and 100 nF.

3.1.3 Class-B

This class of operation can be used for all RF power amplifiers without linearity requirements, e.g. in portable and mobile radios, base stations (except those for the 900 MHz band) and FM broadcast transmitters.

For bipolar transistors, no biasing is required, i.e. $V_{BE} = 0$, while MOSFETS are used with very small quiescent drain current, say 2 to 3% of the current at full power. This can be provided in the same way as for class-AB amplifiers.

The collector (or drain) efficiency is about 70% at VHF, while the power gain depends on the frequency of operation.

3.1.4 Class-C

This class of operation is *not recommended for bipolar transistors*, because it shortens transistor life, see also Section 2.1.1: V_{EBO} rating. An exception can be made for

RF transmitting transistor and power amplifier fundamentals

Power amplifier design

a very small negative bias (<100 mV) which can be generated with a small resistor between base and emitter.

MOSFETS are more tolerant in this respect and can be adjusted at $V_{GS} = 0$, causing only a few dB reduction of power gain. This is not a problem in most cases because the gain is rather high. The main advantage is a higher drain efficiency. A good example is the BLF278 which at 108 MHz in class-B gives 70% efficiency at 22 dB gain, and in class-C, 80% efficiency at 18 dB gain.

3.1.5 Class-E

This class of operation is discussed in more detail in application report "COE82101". With an optimum choice of component values for the output matching network of the transistor, collector or drain efficiencies of 85% can be reached. However, the use of class-E is restricted as beyond 60 to 70 MHz, efficiency falls significantly.

3.1.6 Influence of driver stages on intermodulation

Most linear amplifiers (i.e. class-A and class-AB) consist of a cascade of two or more amplifier stages. The overall distortion is mainly caused by the final stage because the driver stages are generally designed to have a lower distortion. In fact, attention to the design of the driver stage will pay dividends in overall performance as the following analysis illustrates.

The total distortion of a multi-stage amplifier, d_{tot} , can be determined from:

$$d_{tot} = 20 \log \left(10^{d_1/20} + 10^{d_2/20} + \dots \right)$$

where d_1, d_2 etc. are the intermodulation products of each stage in dB.

With two stages, e.g. driver plus a final stage, it is useful to know by how many dB the overall distortion worsens for a given difference in distortion between driver and final stage (assuming the driver distortion is the smaller). This relationship is described by:

$$B = 20 \log \left(1 + 10^{-A/20} \right)$$

where:

A is the absolute difference in distortion between driver and final stage, and

B is the increase in distortion in the output of the amplifier.

This relationship is summarized in Table 3-1 for a few values. Clearly, if a large increase in distortion is unacceptable, the driver stage has to be substantially better than the final stage.

Table 3-1 Effect of driver distortion upon overall distortion

A	B
Amount by which driver IMD is superior to final stage IMD (dB)	Increase in IMD of output amp. (dB)
0	6.0
5	3.9
10	2.4
15	1.4
20	0.8

3.2 Matching

3.2.1 Narrow-band (test) circuits

NARROW-BAND MATCHING CIRCUITS

- Section 3.2.1.1: describes the principles of impedance matching
- Section 3.2.1.2: describes two types of adjustable network, and how to handle high power levels
- Section 3.2.1.3: deals with UHF versions of the networks of the previous section using striplines
- Section 3.2.1.4: discusses the double networks required for very-low transistor impedances
- Section 3.2.1.5: is on π -networks where the trimmers are grounded on one side to avoid 'hand effects'. VHF and UHF versions are given as well as the modifications for low-impedance transistors.

3.2.1.1 GENERAL REQUIREMENTS

Every transistor amplifier needs to be impedance matched both at its input and output. In test circuits, the 50 Ω signal source must be matched to the complex input impedance of the transistor. At the output, the reverse is needed, namely, the 50 Ω load resistance must be transformed to the optimum complex load impedance of the transistor.

In multistage amplifiers, networks are required in addition, to provide direct matching between two complex impedances. The most important requirement for all matching networks is that power losses must be minimized. In addition, especially for output networks, the

RF transmitting transistor and power amplifier fundamentals

Power amplifier design

voltage and current loading of the components must be taken into account.

Most matching networks have to be tunable, ideally with a large tuning range and with smooth, continuous control. Unfortunately, these are conflicting requirements so a compromise must be made.

In general, there are no severe requirements on the bandwidth of a matching network. However, it can be advantageous not to make this bandwidth too small, thereby improving the smoothness of the alignment and reducing losses.

The objective of matching is to maximize power transfer. This requires that the source and load impedances are complex conjugates, i.e. they have equal resistance components, and equal reactance components but of opposite sign.

The simplest form of matching between a source with a real (i.e. resistive) internal impedance and a different load resistance can be made using two reactive elements, see Fig.3-7.

In Fig.3-7, A and B have low-pass characteristics and are most commonly used because of their suppression of harmonic components. C and D have high-pass characteristics and, although used less frequently, have advantages in specific cases such as interstage networks.

The higher resistance is denoted by R_h and the lower by R_l . R_h always has a parallel reactance (X_p) and R_l a series one with opposite sign (X_s).

The component values can be easily calculated from:

$$\frac{X_s}{R_l} = Q = \frac{R_h}{X_p} \tag{1}$$

and

$$\frac{R_h}{R_l} = Q^2 + 1 \tag{2}$$

where Q is the *loaded* Q-factor which has to be small compared with the *unloaded* Q-factor of the components.

Note: Equations (1) and (2) are used on many occasions in subsequent sections to determine component values in networks.

Up to now, we have only considered matching two different value *resistances*. In practice, at least one of the impedances is complex, and in such cases, one of the reactances, namely the one closest to the complex impedance, has to be modified.

Suppose that in Fig.3-7, circuit A is used for the input matching of a transistor. If the transistor's input impedance is capacitive, X_s has to be increased by the absolute value of the transistor's input reactance as Fig.3-8 shows. If the input impedance is inductive, the reverse is needed: X_s has to be reduced by this amount. Note, if in the latter case the input reactance of the transistor is higher than the calculated X_s , the new X_s becomes negative, meaning a capacitor has to be used instead of an inductor.

Similar considerations hold for the other configurations.

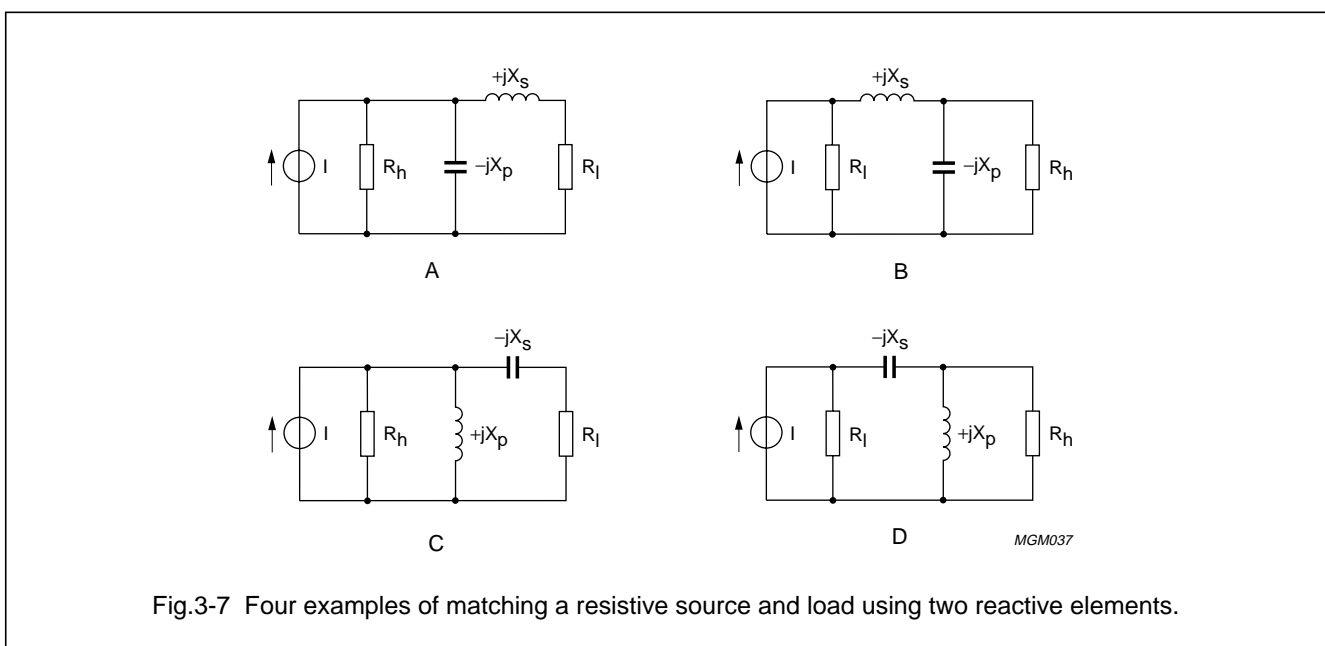

Fig.3-7 Four examples of matching a resistive source and load using two reactive elements.

RF transmitting transistor and power amplifier fundamentals

Power amplifier design

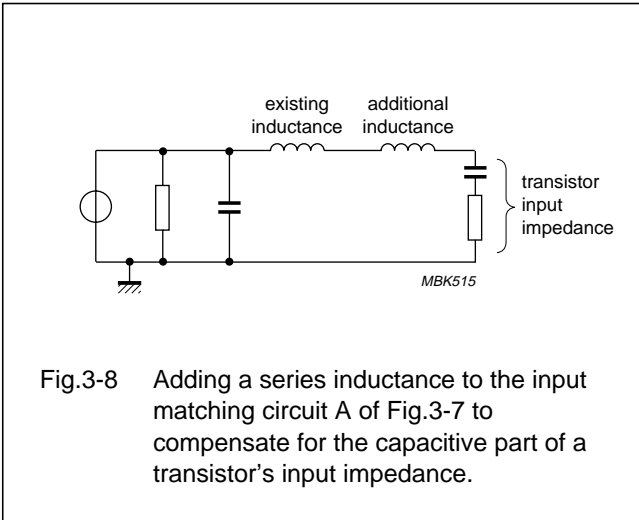

Fig.3-8 Adding a series inductance to the input matching circuit A of Fig.3-7 to compensate for the capacitive part of a transistor's input impedance.

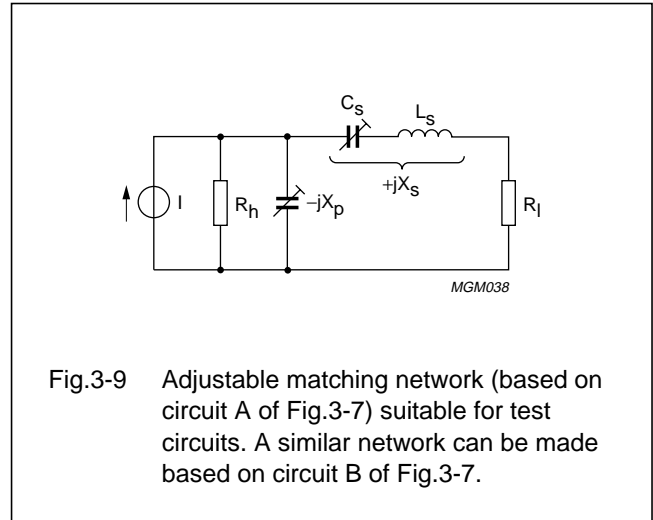

Fig.3-9 Adjustable matching network (based on circuit A of Fig.3-7) suitable for test circuits. A similar network can be made based on circuit B of Fig.3-7.

3.2.1.2 ADJUSTABLE L AND T NETWORKS⁽¹⁾

Owing to their limited control options, the networks described in the previous section are not really suitable for use in test circuits. This limitation can be overcome in two ways by simple circuit modifications.

3.2.1.2.1 NETWORK 1

Starting from circuits A (high-to-low transformation) and B (low-to-high transformation) of Fig.3-7, X_p is made (partly) variable by using a trimmer (optionally with a fixed capacitor in parallel to lower the trimmer current and for smoother control). In addition, a variable capacitor is connected in series with X_s such that the combination remains inductive. (C_s can again be the parallel combination of a trimmer and a fixed capacitor). This means the inductance has to be increased to keep the combination's reactance at the calculated value of X_s , see Fig.3-9.

For the modified network, the new Q-factor for L_s is

$$Q' = \frac{\omega L_s}{R_l}$$

And since L_s has increased, Q' is higher than the Q defined in the previous section, meaning the circuit losses are higher and the bandwidth is lower. Therefore, these effects must be reduced as much as possible by restricting the increase in L_s .

3.2.1.2.2 NETWORK 2

A variant of network 1 is shown in Fig.3-10. This circuit uses smaller capacitances than the circuit of Fig.3-9. And though the harmonic suppression is worse, this can usually be tolerated in input networks.

The calculation of component values is done in two stages. To assist understanding, it is best to imagine this circuit as two cascaded sections (D plus A from Fig.3-7), see Fig.3-11. The first section transforms R_h to a higher value at point A, and the second transforms this value down to R_l . To restrict the losses and reduction of bandwidth, it is advisable to choose the equivalent parallel resistance at point A no higher than necessary. When making the calculation, note that the combined reactance of L_p' and C_p' is always negative (C_p' dominates), so the combination can be realized by a (variable) capacitor.

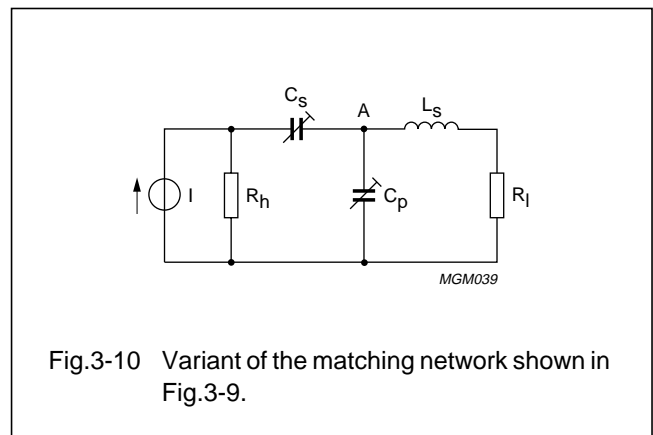

Fig.3-10 Variant of the matching network shown in Fig.3-9.

(1) Note: Many of the networks in Section 3.2 are 'reversible'.

RF transmitting transistor and power amplifier fundamentals

Power amplifier design

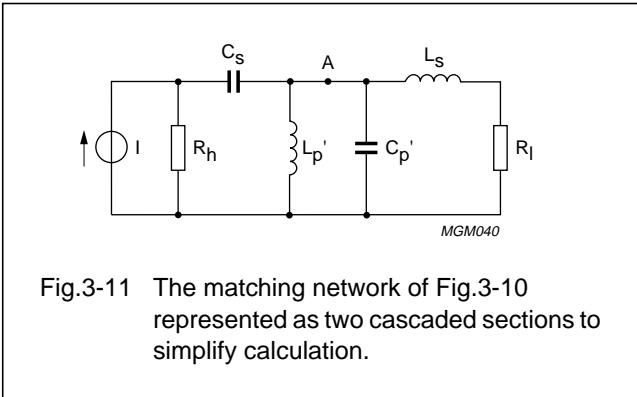

Fig.3-11 The matching network of Fig.3-10 represented as two cascaded sections to simplify calculation.

Another possibility is a combination of networks 1 and 2. This is sometimes used in output networks that must handle relatively high power, see Fig.3-12.

The purpose of C_{p1} is to drain some, say half, of the RF current to ground so that the current through C_s and C_{p2} becomes proportionally smaller, allowing components of a lower rating to be used.

The equivalent parallel resistance at point A should be 2 to 3 times R_h which determines the value of L_s (from equations (1) and (2), the resistance ratio determines the Q, and $X_s = QR_l$). Next, choose a value for C_{p1} that is about half that required to transform R_l to the resistance at point A.

Looking from point A to the left (but including C_{p1}), we see an inductive impedance: $R + jX$, where $R > R_l$. The remaining part of the calculation is then the same as for network 1.

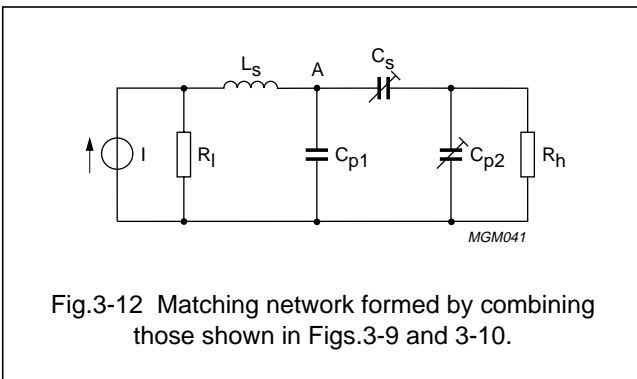

Fig.3-12 Matching network formed by combining those shown in Figs.3-9 and 3-10.

With these and the following networks, it is often needed to transform an impedance from series to parallel components or vice versa. For such transformations, the equations given in the previous section for calculating L-networks can be used with R_l as the series resistance component and R_h as the parallel resistance component.

3.2.1.3 UHF NETWORKS

Above 300 MHz, it is not very practical to work with coils, so transmission lines in the form of striplines are preferred, see Fig.3-13. As well as having series inductance, striplines have parallel capacitance which transforms the real part of the load impedance, calling for a modified calculation.

Figure 3-13 is very similar to the right-hand part of the circuit shown in Fig.3-10. The (low) load impedance is known, but note that its imaginary part can be positive or negative depending on the transistor. And R_{ip} is chosen in the same manner as the resistance at point A in network 2, Section 3.2.1.2.

Next, choose the characteristic resistance of the stripline to satisfy the condition:

$$R_c > \sqrt{R_{ls} R_{ip}}$$

The exact value of R_c is set by practical considerations as both very narrow and very broad striplines are undesirable.

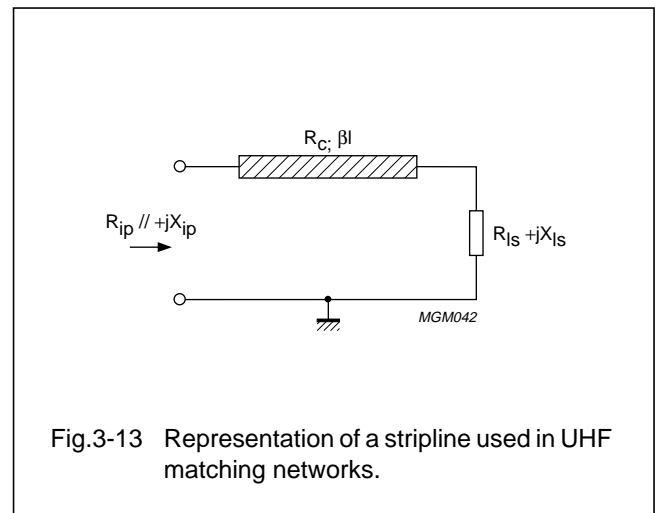

Fig.3-13 Representation of a stripline used in UHF matching networks.

RF transmitting transistor and power amplifier fundamentals

Power amplifier design

It's now possible to calculate the electrical length (βl) and the parallel input reactance (X_{ip}) from the following two equations:

$$\tan \beta l = \frac{-b + \sqrt{b^2 - 4ac}}{2a}$$

where:

$$a = R_c^2 - R_{Is}R_{ip}$$

$$b = 2R_c X_{Is}$$

$$c = R_{Is}^2 + X_{Is}^2 - R_{Is}R_{ip}$$

and:

$$X_{ip} = \frac{R_{Is}R_{ip}}{X_{Is} + \tan \beta l \left(R_c - \frac{R_{Is}R_{ip}}{R_c} \right)}$$

The values of the (variable) capacitors are calculated as described in Section 3.2.1.2.

3.2.1.4 DOUBLE NETWORKS

In some cases, the input and/or load impedance of the transistor is so low that a direct transformation, as just described in Section 3.2.1.3, leads to very high values of the loaded Q-factor with all its negative consequences. It is then better to add an extra (fixed) section as shown in Figs 3-14 and 3-15.

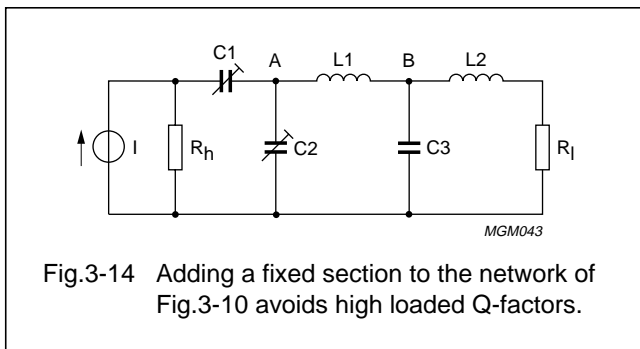

Fig.3-14 Adding a fixed section to the network of Fig.3-10 avoids high loaded Q-factors.

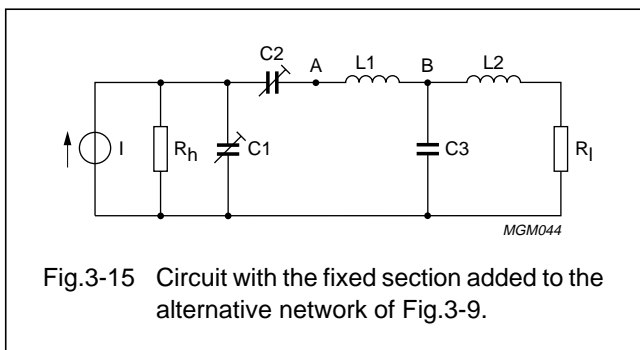

Fig.3-15 Circuit with the fixed section added to the alternative network of Fig.3-9.

Suppose that $R_h = 50 \Omega$ and $R_l = 1 \Omega$. A suitable value for the equivalent parallel resistance at point A is then 100 to 150 Ω (i.e. more than 50 Ω , but not so big in view of circuit losses and bandwidth). At point B, a value which is the geometric mean of that at point A (say 125 Ω) and R_l is required, namely $\sqrt{125 \times 1} = 11.2 \Omega$.

Without the double network, the loaded Q is:
 $\sqrt{125 - 1} = 11.1$

and with the double network, it is :
 $\sqrt{11.2 - 1} = 3.2$ which is a significant improvement.

This double network variant also has advantages for output networks. Furthermore, by replacing some or all of the coils by striplines, it can be used at higher frequencies.

3.2.1.5 PI-NETWORKS

3.2.1.5.1 FOR THE VHF RANGE

The networks considered up to now have used both parallel and series capacitors. This can be undesirable because of the so-called 'hand-effect' (the influence of an operator's capacitance) when adjusting a variable capacitor with an RF signal on both sides of it. This effect is present even when an insulated adjuster is used. An alternative method of impedance matching which uses only parallel capacitors overcomes this problem, see Fig.3-16.

If R_l is the low transistor output impedance and R_h the 50 Ω load resistance, then we start by transforming R_l up to about 50 Ω by the fixed section L_1-C_1 . This fixed section is followed by a Pi-network $C_2-L_2-C_3$ which can transform the impedance either up or down as required, and the Pi-network component values are calculated as follows (see Fig.3-17).

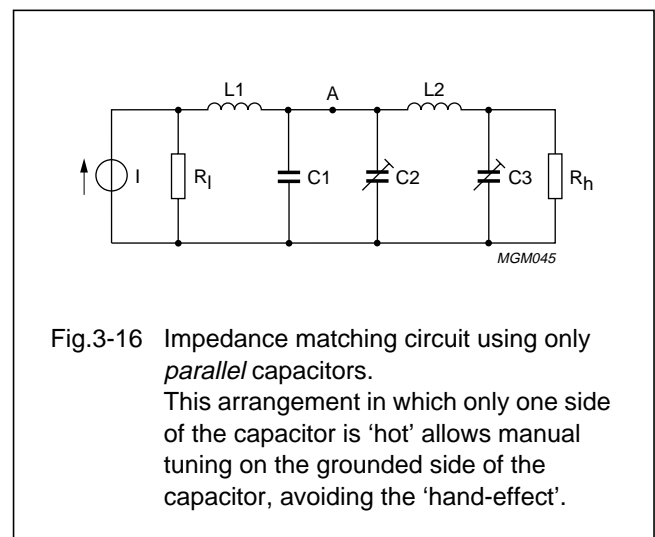

Fig.3-16 Impedance matching circuit using only parallel capacitors. This arrangement in which only one side of the capacitor is 'hot' allows manual tuning on the grounded side of the capacitor, avoiding the 'hand-effect'.

RF transmitting transistor and power amplifier fundamentals

Power amplifier design

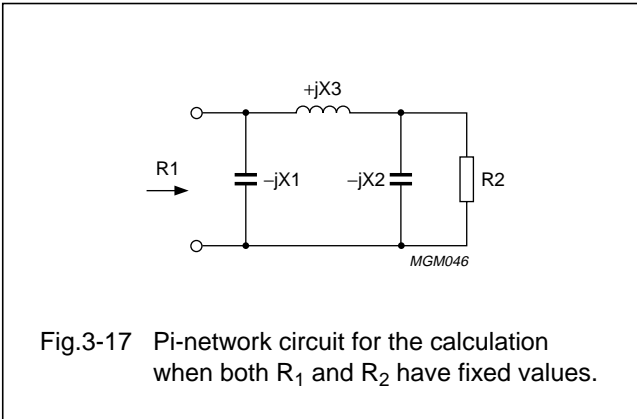

Fig.3-17 Pi-network circuit for the calculation when both R_1 and R_2 have fixed values.

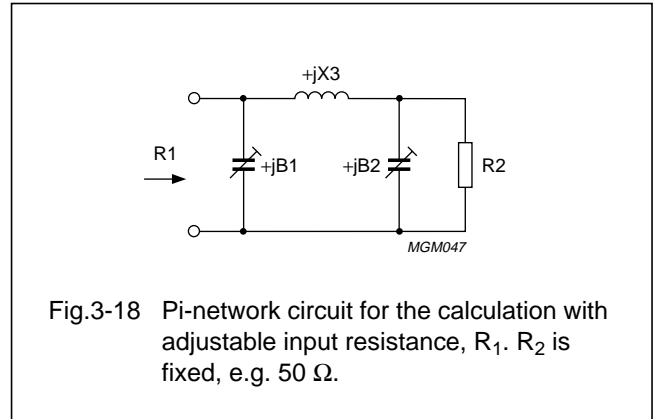

Fig.3-18 Pi-network circuit for the calculation with adjustable input resistance, R_1 . R_2 is fixed, e.g. 50 Ω .

For the condition: $X_3 \leq \sqrt{R_1 R_2}$,

$$X_1 = \frac{R_1 X_3}{R_1 + \sqrt{R_1 R_2 - X_3^2}}$$

and

$$X_2 = \frac{R_2 X_3}{R_2 + \sqrt{R_1 R_2 - X_3^2}}$$

In most cases however, we want to adjust the input resistance by varying X_1 and X_2 , for example, to suit different transistors and for maximum power transfer. Figure 3-18 shows a suitable network in which, for mathematical convenience, susceptances ($B = \omega C$) have been used instead of reactances.

The value required for X_3 is determined by the minimum value of R_1 :

$$X_3 = \sqrt{R_{1 \min} R_2}$$

$$B_{1 \min} = B_{2 \min} = \frac{1}{X_3}$$

$$\Delta B_1 = \frac{1}{2R_{1 \min}}$$

and

$$\Delta B_2 = \frac{\sqrt{\frac{R_{1 \max}}{R_{1 \min}} - 1}}{R_2}$$

So both capacitors have the same minimum value but generally a different control range (Δ).

The losses in this type of Pi-network are in general somewhat higher than those in the networks discussed earlier. The losses increase as the difference between R_1 (avg.) and R_2 increases and as the control range increases since in both cases the loaded Q of the components increases.

The losses can be kept within reasonable limits if the average value of R_1 is within a factor of 2 (up or down) of R_2 (i.e. $R_2/2 < R_1 < 2R_2$). For the control range of R_1 , a factor of 4 (total) is generally suitable, providing a control factor of 2 (up and down) from the nominal value.

3.2.1.5.2 FOR THE UHF RANGE

The network just described can also be made in a stripline version, see Fig.3-19.

The characteristic resistance of the stripline must satisfy the condition:

$$R_c > \sqrt{R_{1 \min} R_2}$$

Then the other quantities become:

$$\tan \beta l = \frac{1}{\sqrt{\frac{R_c^2}{R_{1 \min} R_2} - 1}}$$

$$B_{1 \min} = B_{2 \min} = \frac{1}{R_c \tan \beta l}$$

$$\Delta B_1 = \frac{1}{2R_{1 \min}}$$

$$\Delta B_2 = \frac{\sqrt{\frac{R_{1 \max}}{R_{1 \min}} - 1}}{R_2}$$

RF transmitting transistor and power amplifier fundamentals

Power amplifier design

So clearly this stripline network has much in common with the previous one.

3.2.1.5.3 PI-NETWORK MODIFICATIONS FOR LOW-IMPEDANCE TRANSISTORS

If the transistor impedance is very low (say $<5 \Omega$) as occurs in high power situations, there are two options:

1. Make the average value of R_1 lower than R_2 , e.g. half of R_2
2. Use two pre-matching sections instead of one. If this is done, make the impedance between the two sections equal to the geometric mean of the transistor impedance and the average input resistance of the Pi-network.

3.2.2 Wideband circuits

WIDEBAND HF MATCHING CIRCUITS OVERVIEW

HF range (Section 3.2.2.1)

- Describes the procedures for input/output matching of MOS and bipolar transistors. Most attention is paid to MOS devices as they are usually the preferred choice for HF applications.
- Section 3.2.2.1.1 describes some output compensation circuits. Output compensation aims to maintain the ideal load impedance over the frequency band of interest to obtain the highest efficiency and lowest distortion. This section explains:
 - * How to compensate a transistor's output capacitance with one or two elements - the latter giving superior results
 - * How to compensate parallel inductances such as RF chokes and/or transformer inductance to improve performance at the lower end of the band, and the selection of compensation (coupling) capacitor(s).
- Section 3.2.2.1.2 deals with the design of input networks to obtain low input VSWR, and high, flat power gain over the whole frequency band.

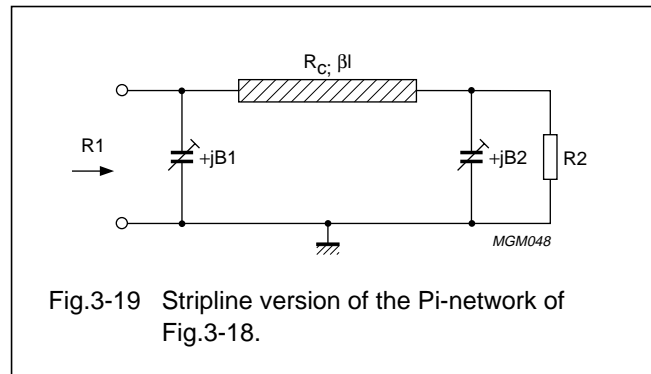

Fig.3-19 Stripline version of the Pi-network of Fig.3-18.

3.2.2.1 THE HF RANGE

This frequency range covers 1.6 to 28 MHz. Most transmitters in this range work with single sideband modulation and wideband power amplifiers. The impedance transformation in these amplifiers can be done either by transmission line type transformers or by compensated conventional transformers (extensively described in application reports "ECO6907" and "ECO7213").

In addition, a number of compensation techniques can be used at both output and input. For the former, this is done to obtain maximum output power and efficiency over the whole frequency band; for the latter, it's done to obtain maximum and flat power gain and good impedance matching over the band.

3.2.2.1.1 COMPENSATION AT THE OUTPUT

Compensation of output capacitance

Take as an example the BLF177 MOS transistor. From the published data sheet, this has an output capacitance of 190 pF which rises at full power by about 15% to 220 pF. The capacitor reactance at 28 MHz is about four times the load resistance of 6.25 Ω . Without compensation, the output VSWR is 1.28 which is rather high. To reduce this VSWR, one or two external components can be used. Compensation with one element is shown in Fig.3-20. Two elements will of course give a better result than one, and is described later.

These compensation examples make use of Chebyshev filter theory where it is usual to express the values of the filter elements normalized to a characteristic resistance (source and/or load resistance) of 1 Ω and to a cut-off (angular) frequency, ω , of 1 rad/s. For a low-pass filter, 1 rad/s is the maximum angular frequency, and for a high-pass filter the minimum. Normalized quantities are denoted by g_k where k is a filter-element identifier (Ref.1).

RF transmitting transistor and power amplifier fundamentals

Power amplifier design

Single-element compensation

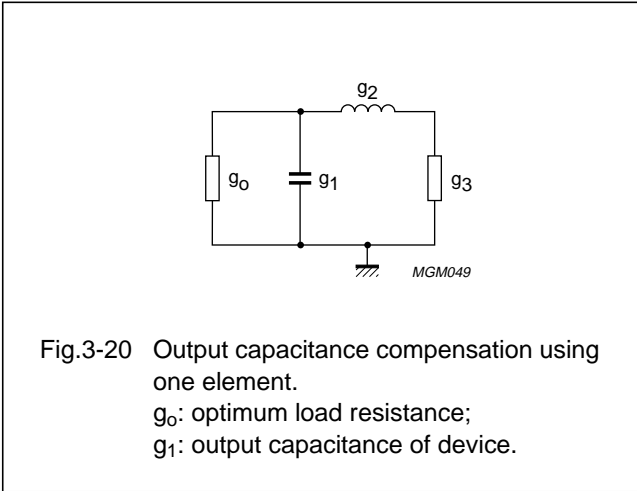

In the circuit of Fig.3-20, the filter elements are:

- g_0 : the optimum load resistance (known);
- g_1 : the output capacitance of the device (known);
- g_3 : the real load resistance, and
- g_2 : the compensating element inductance.

In normalized form, we can express these quantities as:

$$g_1 = \frac{\sqrt{2}}{\gamma}$$

$$g_2 = \frac{\sqrt{2}\gamma}{1 + \gamma^2}$$

$$g_3 = \frac{g_0\gamma^2}{1 + \gamma^2}$$

where γ is an intermediate quantity (mathematically related to the maximum VSWR in the pass-band) used to simplify the calculations.

From the above, it follows that:

$$g_2 = \frac{2g_1}{g_1^2 + 2}$$

In general, $g_1 \ll 1$, so $\gamma \gg 1$ and as a result, $g_3 \sim g_0$.

(De)normalization can be done using:

$$g_0 = R$$

$$g_1 = \omega CR$$

$$g_2 = \omega L/R$$

where: ω is the *maximum* angular frequency, and the maximum VSWR is g_0/g_3 .

In the example with the BLF177:

$$g_1 = 1/4$$

$$g_2 = 0.2424 \text{ (normalized value), so } L = 8.61 \text{ nH.}$$

Therefore, the VSWR is 1.031 - a substantial improvement. And though not necessary in this case, it can be made better still as required in driver stages for which compensation with two elements, see Fig.3-21, is preferred.

Two-element compensation

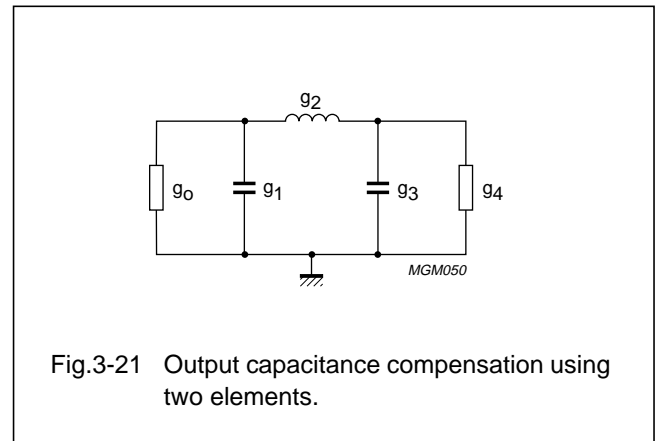

The calculation is similar to that just described, so in normalized form:

$$g_0 = g_4$$

$$g_1 = g_3 = \frac{1}{\gamma}$$

$$g_2 = \frac{2\gamma}{\gamma^2 + \frac{3}{4}}$$

From this, it follows that:

$$g_2 = \frac{8g_1}{3g_1^2 + 4}$$

Normalization and denormalization is done using:

RF transmitting transistor and power amplifier fundamentals

Power amplifier design

$$g_0 = g_4 = R$$

$$g_1 = g_3 = \omega CR$$

$$g_2 = \omega L/R$$

where ω is again the *maximum* angular frequency.

The maximum VSWR is calculated as follows. For the calculation, it is necessary to introduce a term k where:

$$k = \gamma + \sqrt{\gamma^2 + 1}$$

Then:

$$VSWR = \left(\frac{k^3 + 1}{k^3 - 1} \right)^2$$

In the example with the BLF177:

$$g_1 = 1/4$$

$$\gamma = 4$$

$$g_2 = 0.4776 \text{ (so } L = 17 \text{ nH)}$$

Therefore, the VSWR = 1.007.

This is principally the same as the HF compensation of a conventional transformer. The only difference is that in the latter case the stray inductance is known and the compensation capacitors have to be calculated.

Compensation of parallel inductances

COMPENSATING ONE PARALLEL INDUCTANCE

It is also worthwhile compensating for the parallel inductances of the RF choke and output transformer found in most amplifiers as their reactances at 1.6 MHz are often about four times the load resistance. In most cases, compensation is provided by the coupling capacitor(s).

There are also simpler situations where either the RF choke or the impedance transformer is missing. We will start with this case and the equivalent circuit is given in Fig.3-22.

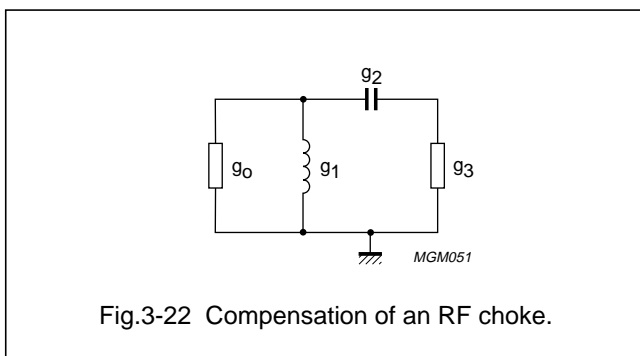

Fig.3-22 Compensation of an RF choke.

This circuit looks much the same as the HF compensation scheme, with the L and the C interchanged.

Mathematically, there is also much in common - only the normalized values have to be inverted. So, for the reactive elements:

$$g_1 = \frac{\gamma}{\sqrt{2}}$$

$$g_2 = \frac{1 + \gamma^2}{\sqrt{2}\gamma}$$

$$g_3 = \frac{g_0\gamma^2}{1 + \gamma^2}$$

From these, it follows that:

$$g_2 = \frac{1 + 2g_1^2}{2g_1}$$

In general, g_1 and γ are $\gg 1$, so $g_3 \sim g_0$.

Normalization and denormalization are done using:

$$g_0 = R$$

$$g_1 = \omega L/R$$

$$g_2 = \omega CR$$

where ω is the *minimum* angular frequency, and the maximum VSWR is again g_0/g_3 .

COMPENSATING TWO PARALLEL INDUCTANCES

If we have to compensate two parallel inductances of approximately equal value, the equivalent circuit is as shown in Fig.3-23.

Inverting the normalized values for the reactive elements gives:

$$g_0 = g_4$$

$$g_1 = g_3 = \gamma$$

$$g_2 = \frac{\gamma^2 + \frac{3}{4}}{2\gamma}$$

From these, it follows that:

$$g_2 = \frac{4g_1^2 + 3}{8g_1}$$

RF transmitting transistor and power amplifier fundamentals

Power amplifier design

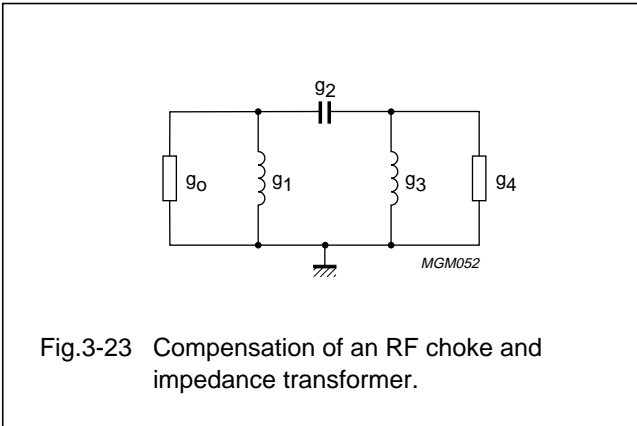

Fig.3-23 Compensation of an RF choke and impedance transformer.

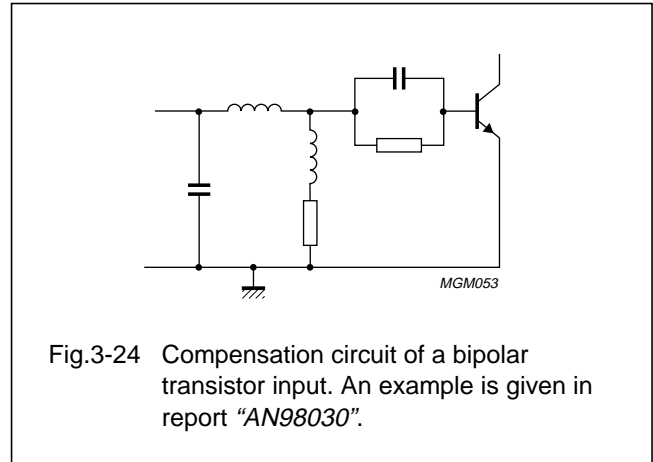

Fig.3-24 Compensation circuit of a bipolar transistor input. An example is given in report "AN98030".

Normalization and denormalization is done using:

$$g_0 = g_4 = R$$

$$g_1 = g_3 = \omega L/R$$

$$g_2 = \omega CR$$

where ω is the *minimum* angular frequency and the maximum VSWR is determined in the same way as in the HF situation. So, if $k = \gamma + \sqrt{\gamma^2 + 1}$ as defined earlier:

$$VSWR = \left(\frac{k^3 + 1}{k^3 - 1} \right)^2$$

In the example with a BLF177:

$$g_1 = 4$$

$$\gamma = 4$$

$$g_2 = 2.094$$

Therefore, the VSWR = 1.007

For $R = 6.25 \Omega$ and $f = 1.6 \text{ MHz}$, we get $C = 33 \text{ nF}$.

3.2.2.1.2 COMPENSATION AT THE INPUT

For bipolar transistors, the variations in power gain and input impedance can be compensated with an R-L-C network as described in application report "AN98030", and shown in Fig.3-24. The network was designed using a circuit analysis program with an optimization facility.

For MOS transistors, the behaviour of the input impedance is quite different. The main problem here is providing a constant voltage across a rather high input capacitance (for the BLF177: about 745 pF) over the frequency range. At the same time, we want good matching at the input *and* the highest power gain.

Simply connecting a resistor across the transistor input does not produce good results. Better solutions, the simplest of which is described here (see Fig.3-25), are required. The more advanced ones will be discussed later where their superior performance is really needed.

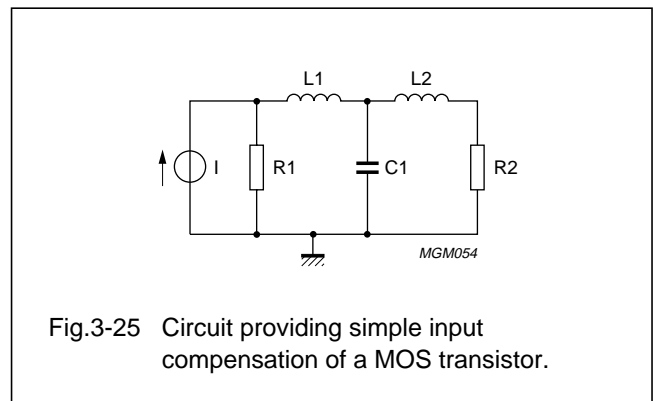

Fig.3-25 Circuit providing simple input compensation of a MOS transistor.

In Fig.3-25, the (transformed) driving generator is represented by the combination I-R₁, and the input capacitance of the transistor by C₁. The compensation components are: L₁, L₂ and R₂. R₂ should approximately equal R₁. In addition, the voltage across C₁ should not differ much from that across R₁. As the required voltage across C₁ is a given quantity, we shall design a circuit with the highest possible value of R₁ to obtain the lowest possible drive power.

Computer optimization programs can be used to investigate what happens when the product R₁C₁ is increased. The aims of optimization are to:

- Minimize the input VSWR over the frequency band, and
- Minimize the variation of the voltage across C₁ over the same band.

RF transmitting transistor and power amplifier fundamentals

Power amplifier design

Table 3-2 gives the normalized results from such a program.

Table 3-2 Effect of varying $\omega C_1 R_1$ in the compensation circuit of Fig.3-25

$\omega C_1 R_1$	$\omega L_1 / R_1$	$\omega L_2 / R_1$	R_2 / R_1	VSWR _{max}	ΔG (dB)
0.8	0.437	0.305	0.961	1.21	0.19
1.0	0.515	0.388	0.939	1.34	0.31
1.2	0.571	0.473	0.908	1.51	0.44
1.4	0.619	0.568	0.867	1.74	0.64

ω is the maximum angular frequency, and ΔG the maximum deviation from the average gain.

From Table 3-2, clearly, a good practical choice is $\omega C_1 R_1 = 1.0$. For the BLF177, this means that R_1 can be 7.6 Ω maximum. For ease of transformation, we chose 6.25 Ω .

The input impedance of the transistor is not of course a pure capacitance. It also has some series resistance and inductance, so reoptimization is necessary to take account of the real input impedance and power gain of the transistor as a function of frequency.

For driver stages operating at a low power level, negative feedback is sometimes used: an emitter resistor and a collector-base resistor for bipolar devices (with in some cases an inductance in series with the latter to reduce feedback at the high end of the frequency band).

Similarly, for MOS transistors, a resistor is connected between drain and gate. A resistor is not required in the source lead however. The advantage of this feedback method is lower intermodulation distortion. The feedback must not be too large however as such a resistor consumes part (albeit a small part) of the output power.

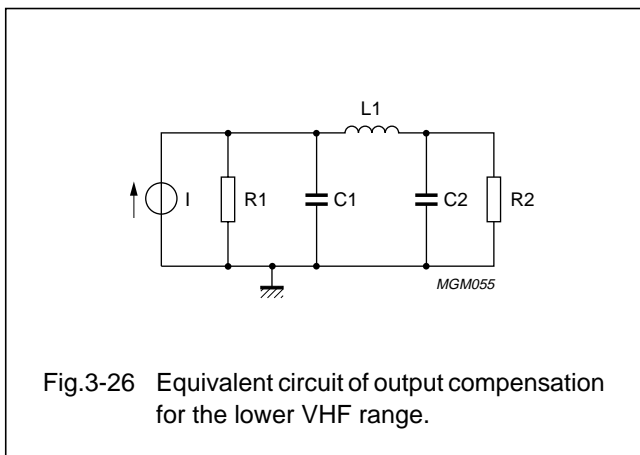

Fig.3-26 Equivalent circuit of output compensation for the lower VHF range.

3.2.2.2 THE LOWER VHF RANGE

WIDEBAND VHF MATCHING CIRCUITS OVERVIEW

Lower VHF range (Section 3.2.2.2)

- Though the same circuit configurations used for HF can be used in this range, the higher maximum frequency requires modified component values.
- Section 3.2.2.2.1 describes two circuits that compensate for output capacitance.
- Section 3.2.2.2.2 describes two input networks using more compensation elements than the HF version for higher power gain.

Upper VHF range (Section 3.2.2.3)

- Describes impedance matching (input and output) for this range using low-pass L-sections, with an optional high-pass section.
- Section 3.2.2.3.1 describes a single low-pass section, sufficient for low impedance ratios and/or moderate bandwidths. To meet more stringent requirements, two or three sections are required. Section 3.2.2.3.2 outlines several approaches, some suitable for interstage networks.
- Finally, the effect of non-ideal network components is discussed.

Some military communications transmitters operate in this range. The lowest frequencies used are 25 to 30 MHz and the highest 90 to 110 MHz.

Power amplifiers for this range are similar to those for the HF range. However, impedance matching can only be done with transmission line transformers as described in application report "ECO7703". In addition, more complex methods are required for RF compensation at both output and input.

3.2.2.2.1 COMPENSATION AT THE OUTPUT

The output compensation systems described in Section 3.2.2.1.1 provide adequate results in the HF range. For the lower VHF range, somewhat better results can be obtained simply by modifying the component values. The equivalent circuit is shown in Fig.3-26.

First, let $R_1 = R_2$; C_2 does not however have to equal C_1 . Computer optimization for lower VHF yields the results shown in Table 3-3.

RF transmitting transistor and power amplifier fundamentals

Power amplifier design

The practical limit of usefulness is at $\omega C_1 R_1 = 1.0$. If we use this condition with the Chebyshev system described earlier, then the maximum VSWR would be 1.33 instead of 1.29.

Table 3-3 Computer optimization results of the compensation circuit of Fig.3-26 for the lower VHF range

$\omega C_1 R_1$	$\omega C_2 R_1$	$\omega L_1 / R_1$	VSWR _{max}
0.6	0.549	0.914	1.08
0.8	0.693	1.04	1.17
1.0	0.827	1.10	1.29
1.2	0.965	1.12	1.44

ω is the maximum angular frequency. $R_1 = R_2$.

With this compensation, we can go one step further by dropping the requirement that R_2 has to equal R_1 . Doing this and optimizing again yields the results shown in Table 3-4.

As Table 3-4 shows, for $\omega C_1 R_1 = 1.0$, the maximum VSWR is improved to 1.25, and the corresponding value of R_2 is now smaller than R_1 . Whether this is an advantage or not is difficult to say as it is dependent on the desired combination of supply voltage and output power as well as on the possible transformer ratios.

Table 3-4 Computer optimization results of the compensation circuit of Fig.3-26 for the lower VHF range. $R_1 \neq R_2$

$\omega C_1 R_1$	$\omega C_2 R_1$	$\omega L_1 / R_1$	R_2 / R_1	VSWR _{max}
0.6	0.468	0.818	0.939	1.08
0.8	0.615	0.922	0.897	1.16
1.0	0.738	0.943	0.838	1.25
1.2	0.886	0.943	0.783	1.36

ω is the maximum angular frequency, and $R_1 \neq R_2$.

3.2.2.2.2 INPUT NETWORKS

For bipolar transistors, it should be possible to use the same type of compensation network used for the HF range in the lower VHF range. However, we shall restrict our considerations to input networks for use with MOS devices.

The problem is the same as for the HF range (maintaining a constant voltage across a capacitance over a wide frequency range, see Section 3.2.2.1.2), but with a substantially higher maximum frequency. So, a more efficient compensation network is needed, requiring more

components. The first of two examples is shown in Fig.3-27.

C_2 represents the input capacitance of the transistor. The results obtained by computer optimization are shown in Table 3-5.

Compared with the network described earlier (Fig.3-25 and Table 3-2), there is substantial improvement because $\omega R_1 C_2$ can certainly be increased up to 1.6, compared with 1.0 for the simpler network, providing higher gain for a given bandwidth.

A second circuit configuration producing as good or even superior results is shown in Fig.3-28. Here, the input capacitance of the transistor is represented by C_1 . Computer optimization yields the results summarized in Table 3-6.

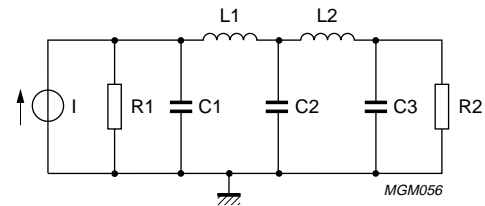

Fig.3-27 Example of an improved compensation circuit for the lower VHF range.

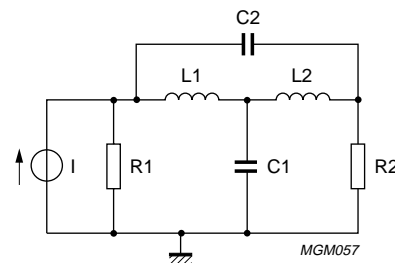

Fig.3-28 Second example of an improved compensation circuit for the lower VHF range.

RF transmitting transistor and power amplifier fundamentals

Power amplifier design

Table 3-5 Computer optimization results of the compensation circuit of Fig.3-27

$\omega R_1 C_2$	$\omega R_1 C_1$	$\omega R_1 C_3$	$\omega L_1 / R_1$	$\omega L_2 / R_1$	R_2 / R_1	VSWR _{max}	ΔG (dB)
1.0	0.460	0.501	0.870	0.836	1.02	1.10	0.10
1.2	0.602	0.496	1.02	0.836	1.00	1.14	0.15
1.4	0.751	0.485	1.11	0.836	0.977	1.21	0.20
1.6	0.887	0.476	1.15	0.845	0.955	1.31	0.28
1.8	0.993	0.482	1.15	0.870	0.934	1.42	0.38

ω is the maximum angular frequency and ΔG the maximum deviation from the average gain.

Table 3-6 Computer optimization results of the compensation circuit of Fig.3-28

$\omega C_1 R_1$	$\omega C_2 R_1$	$\omega L_1 / R_1$	$\omega L_2 / R_1$	R_2 / R_1	VSWR _{max}	ΔG (dB)
1.0	0.591	0.392	0.336	0.977	1.12	0.11
1.2	0.597	0.447	0.396	0.972	1.15	0.13
1.4	0.604	0.504	0.462	0.966	1.19	0.16
1.6	0.584	0.584	0.536	0.961	1.21	0.18
1.8	0.584	0.662	0.611	0.955	1.23	0.20
2.0	0.574	0.794	0.733	0.934	1.21	0.36

ω is the maximum angular frequency and ΔG the maximum deviation from the average gain.

Comparing these results with those of the previous case, we see that the product $\omega C_1 R_1$ can be increased to 1.8 and possibly to 2.0. So, this configuration, even though it uses one component fewer, is better. Experience shows that circuits using inductive coupling between L_1 and L_2 do not improve the VSWR and gain variation performance.

As mentioned earlier, the input impedance of a MOS transistor can be represented by a capacitance, inductance and resistance in series. At high power levels in particular, the resistance cannot be neglected.

As a guideline, reoptimization is necessary when the values of input VSWR and gain variation are inferior to those in Tables 3-2, 3-5 and 3-6.

3.2.2.3 THE UPPER VHF RANGE

To get an idea of the impedance levels in this frequency range, consider a BLF225 MOS transistor able to deliver 30 W at 175 MHz from a 12.5 V supply voltage (Note, bipolar devices for the same range have similar impedance levels).

Suppose that the BLF225 is used in a mobile radio transmitter for the range 132 to 174 MHz. The optimum load impedance is about 2.5 Ω with a rather small reactive component. At the transistor input, there is an effective capacitance of 215 pF in series with a resistance of 3.2 Ω and a small inductance of 0.21 nH.

In the literature, most networks for wideband impedance matching are based on pure resistances. So, we have to start by making the impedance at the input approximately real. In theory, this can be done with either a parallel or a series inductance. Though the former should be preferable as it provides a higher impedance, unfortunately, a small inductance in parallel with the input of a transistor can cause large parasitic oscillations. Therefore, we have to use a series inductance, giving a tuned circuit with a loaded Q-factor of 1.53 in the middle of the frequency band. The relative width of this band ($\Delta f/f_0$) is 27 to 28%. If the product of loaded Q-factor and relative bandwidth is much less than 1, as in this case, the matching will not be affected significantly.

The remaining task is to match resistances of 3.2 Ω and 2.5 Ω to a 50 Ω source and load over the range 132 to 174 MHz. The most popular type of network for this purpose comes from G.L. Matthaei (Ref.2) where the matching is obtained from one or more low-pass L-sections (the more sections, the lower the VSWR in the pass-band).

The essence of this method is that there are several frequencies in the pass-band at which exact matching occurs. The number of exact matches is equal to the number of sections.

RF transmitting transistor and power amplifier fundamentals

Power amplifier design

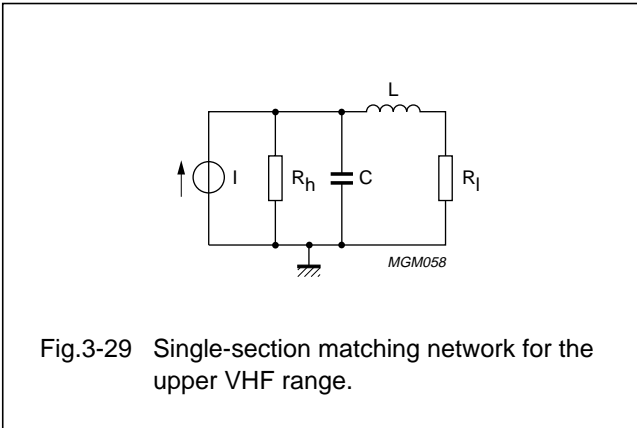

Fig.3-29 Single-section matching network for the upper VHF range.

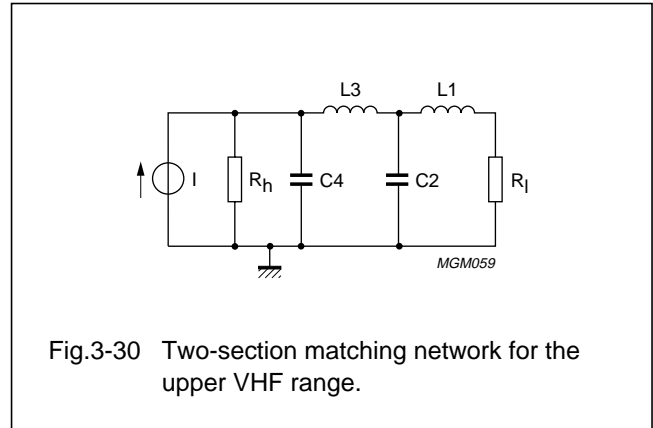

Fig.3-30 Two-section matching network for the upper VHF range.

3.2.2.3.1 SINGLE-SECTION MATCHING

First consider when there is just one section, Fig.3-29. R_h is the higher of the two resistances and R_l the lower. Exact matching takes place at:

$$f_0 = \sqrt{\frac{1}{2}(f_l^2 + f_h^2)}$$

where f_l is the lower limit of the band and f_h the upper one.

L and C can be calculated in the same way as described in Section 3.2.1.1. The maximum VSWR in the pass-band follows from the input impedance at one of the band limits.

The results of the calculation for the output, where 2.5Ω must be matched to 50Ω , are:

$$f_0 = 154.4 \text{ MHz}$$

$$L = 11.23 \text{ nH}$$

$$C = 89.84 \text{ pF}$$

$$\text{VSWR} = 2.974.$$

The VSWR calculation is rather complex and is best done using a circuit analysis program. The high VSWR obtained here indicates that one section is not sufficient. Therefore, we shall now consider some possibilities with two sections.

3.2.2.3.2 TWO-SECTION MATCHING

Two low-pass sections

If both sections are low-pass, the situation is as shown in Fig.3-30.

Exact matching takes place at f_1 and f_2 ($f_2 > f_1$) and:

$$f_1 = \frac{1}{2} \sqrt{(2 + \sqrt{2}) f_l^2 + (2 - \sqrt{2}) f_h^2} \text{ and}$$

$$f_2 = \frac{1}{2} \sqrt{(2 - \sqrt{2}) f_l^2 + (2 + \sqrt{2}) f_h^2}$$

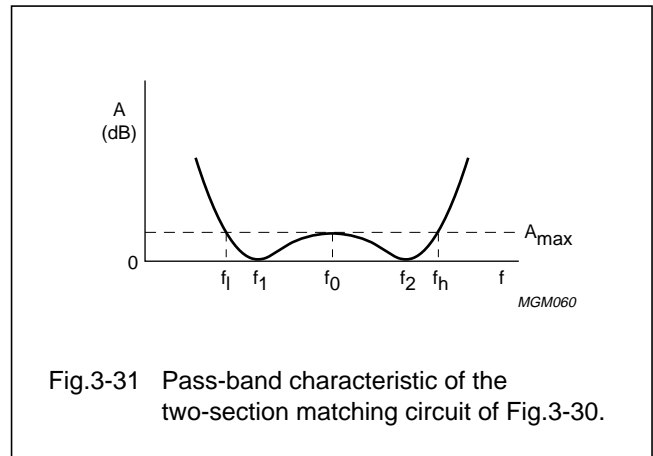

Fig.3-31 Pass-band characteristic of the two-section matching circuit of Fig.3-30.

There is maximum attenuation at the band limits, but also at:

$$f_0 = \sqrt{\frac{1}{2}(f_l^2 + f_h^2)}$$

The pass-band characteristic is shown in Fig.3-31.

To determine the values of the components, we need to define an auxiliary quantity M where:

$$M = L_1 C_2 = \frac{\sqrt{1 - \frac{R_h}{R_l}}}{\omega_1 \omega_2}$$

in which $\omega_1 = 2\pi f_1$
and $\omega_2 = 2\pi f_2$.

Then, for the circuit of Fig.3-30:

$$L_1 = \sqrt{\frac{-p}{2} + \sqrt{\frac{p^2}{4} - q}}$$

RF transmitting transistor and power amplifier fundamentals

Power amplifier design

where:

$$p = -R_l \{MR_h(\omega_1^2 M - 2) + (R_h - R_l)/\omega_1^2\}, \text{ and}$$

$$q = -M^2 R_l^3 R_h$$

And, for the other components:

$$C_2 = M/L_1$$

$$L_3 = C_2 R_l R_h$$

$$C_4 = L_1/(R_l R_h).$$

To calculate the maximum VSWR in the pass-band, the procedure used for single-section matching must again be followed.

For this example, where we need to match from 2.5 to 50 Ω in the frequency range 132 to 174 MHz, we obtain:

$$f_1 = 138.9 \text{ MHz} \quad C_2 = 197.4 \text{ pF}$$

$$f_2 = 168.5 \text{ MHz} \quad L_3 = 24.67 \text{ nH}$$

$$L_1 = 5.343 \text{ nH} \quad C_4 = 42.74 \text{ pF}$$

The maximum VSWR (from the circuit analysis program) in the pass-band is now 1.173, which is a far better result than with one section (2.974).

Though the calculation procedure described above is rather complicated, direct use of the Matthaei method (Ref.2) is not simple either because:

- Interpolation is required both for impedance ratio and relative bandwidth
- Denormalization must be used, and
- Insertion loss must be converted to VSWR.

One low-pass and one high-pass section

Another method of wideband impedance matching is described by U. Fleischmann. (Refs 3, 4 and 5). In this method, two L-sections are used: one low-pass, the other high-pass. Both sequences are possible, and the resulting pass-band characteristic is almost equal to that of the previous case with two sections. To simplify calculation, we need to define several quantities:

$$f_0 = \sqrt{f_l f_h}$$

where f_l and f_h are the lower and upper limits of the frequency band respectively.

$$d = \frac{f_h - f_l}{f_0}$$

$$m = \frac{R_h}{R_l}$$

$$\epsilon = \frac{-d^2 \sqrt{m}}{4} + \sqrt{\left(\frac{d^2 \sqrt{m}}{4}\right)^2 + \left(\frac{d^2 + 2}{2}\right)}, \text{ and}$$

$$k = \epsilon \sqrt{m}.$$

Now we are able to calculate the normalized component values, first for when the low-pass section is adjacent to the lower resistance, R_l , see Fig.3-32.

LOW-PASS SECTION NEAR R_l

In this case:

$$g_1 = \frac{1}{k} \sqrt{\frac{k-1}{m}}$$

$$g_2 = \sqrt{m(k-1)}$$

$$g_3 = \sqrt{\frac{m}{k-1}}$$

$$g_4 = \frac{k}{\sqrt{m(k-1)}}$$

Denormalization can be done for each element using:

$$g = \omega_0 L/R_h \text{ and}$$

$$g = \omega_0 C R_h$$

$$\text{where } \omega_0 = 2\pi f_0$$

Then, the maximum VSWR in the pass-band becomes:

$$\text{VSWR} = 1/\epsilon^2$$

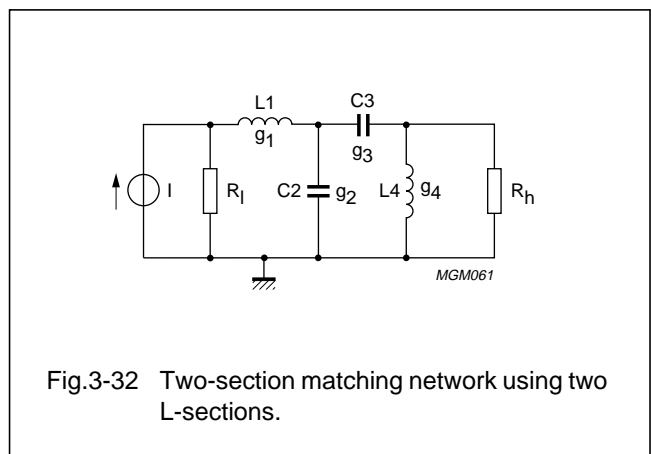

Fig.3-32 Two-section matching network using two L-sections.

RF transmitting transistor and power amplifier fundamentals

Power amplifier design

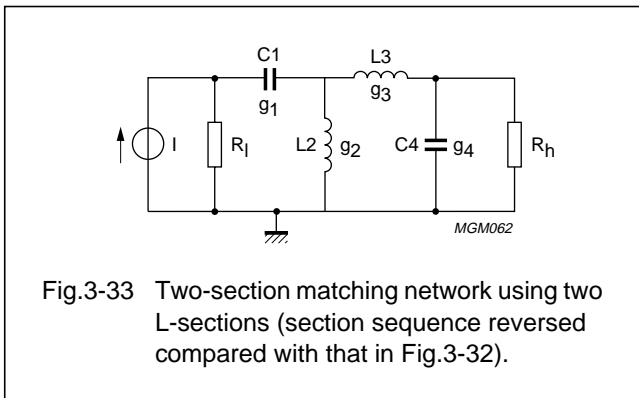

Fig.3-33 Two-section matching network using two L-sections (section sequence reversed compared with that in Fig.3-32).

LOW-PASS SECTION NEAR R_H

If the sequence of the sections is now reversed, the situation is as in Fig.3-33.

In this case, the normalized element values have to be inverted, so:

$$g_1 = k \sqrt{\frac{m}{k-1}}$$

$$g_2 = \frac{1}{\sqrt{m(k-1)}}$$

$$g_3 = \sqrt{\frac{k-1}{m}}$$

$$g_4 = \frac{1}{k} \sqrt{m(k-1)}$$

Denormalization is done as in the previous case, and the maximum VSWR remains the same (1/ε²).

To match 2.5 to 50 Ω over 132 to 174 MHz, (see Section 3.2.2.3.2), the calculation gives the following results:

1st case (circuit as in Fig.3-32):

$$L_1 = 5.005 \text{ nH} ; C_2 = 167.7 \text{ pF}$$

$$C_3 = 52.6 \text{ pF} ; L_4 = 27.54 \text{ nH}$$

2nd case (circuit as in Fig.3-33):

$$C_1 = 220.3 \text{ pF} ; L_2 = 6.575 \text{ nH}$$

$$L_3 = 20.97 \text{ nH} ; C_4 = 40.04 \text{ pF}$$

$$\text{VSWR (both cases)} = 1.14$$

The results are slightly better than those obtained with two low-pass sections. Other advantages are:

- Easier calculation
- Useful for interstage networks.

A disadvantage is the reduced suppression of harmonics.

Effect of real ('imperfect') components on the calculations

When implementing these wideband networks, keep in mind that capacitors, even surface-mount (chip) capacitors, are not ideal components. A chip capacitor, for example, has a series inductance of about 1 nH. In the example with two low-pass sections, a capacitance of 197 pF was required. If two capacitors in parallel are used, their combined inductance is 0.5 nH. As a consequence, we have to reduce the capacitance to C' where:

$$C' = \frac{C}{\omega^2 LC + 1}$$

Note, ω is the average angular frequency of the band, so in the example:

$$C' = \frac{197}{1.09} = 181 \text{ pF}$$

3.2.2.4 THE LOWER UHF RANGE

For the lower UHF range, the methods used in the upper VHF range can again be employed. However, it is not always very practical to use discrete inductances because of the very low values required, and these should then be replaced by striplines.

Note that a stripline is not a pure series inductance; it has parallel capacitance which must be taken into account in any network design. In addition, a particular inductance can be obtained with striplines of different characteristic resistance, R_c. Wherever, possible, use striplines with relatively high R_c as they generally have lower parallel capacitances.

If a transmission line is shorter than 1/8th of a wavelength, a good approximation is the LC equivalent circuit shown in Fig.3-34 where:

$$L = R_c l/v$$

$$C = l/R_c v$$

where v = 3x10⁸/√ε_r. (ε_r being the effective relative dielectric constant of the print board).

What was said about the parasitic inductance of real capacitors at VHF frequencies is of course even more relevant at UHF frequencies.

RF transmitting transistor and power amplifier fundamentals

Power amplifier design

WIDEBAND UHF MATCHING CIRCUITS OVERVIEW

Lower UHF range (Section 3.2.2.4)

- In this range, the techniques used in the upper VHF range can again be used. The main difference is the more frequent use of striplines. In Section 3.2.2.4, the equivalence between striplines and LC-networks is given.

Upper UHF range (Section 3.2.2.5)

- This section outlines the considerations for very wide bandwidths (about 1 octave).
- Section 3.2.2.5.1 covers the use of band-pass networks for the output circuit. These are based on an equivalent low-pass circuit and contain one or two Norton transformations (inductive and capacitive) including T and Pi equivalents.
- Input networks for this range are usually designed for the highest possible flat power gain, and often have a poor input VSWR at the lower end of the range. To improve performance, two identical amplifiers can be combined with 3 dB 90° hybrid couplers as outlined in Section 3.2.2.5.2. Constructing couplers for less-demanding applications is also described, as is the design procedure for the input matching network.

the resistance ratio and/or the relative bandwidth increases.

Now consider when one or both impedances have a large reactive component - a parallel-RC combination, or a series-RL circuit. In both cases, a time constant, τ , is involved: $\tau = RC$ or L/R .

According to Bode (see also Refs 6 and 7), there is a limit to the reflection coefficient, r , which can be achieved in the pass-band. This limit depends on the time constant and the required (absolute) bandwidth, even when the number of elements in the matching network is made arbitrarily high and is:

$$\int_0^{\infty} \ln \left| \frac{1}{r} \right| d\omega = \frac{\pi}{\tau}$$

If we assume that r is constant in the pass-band, and equal to one in the stop-bands, this relation can be simplified to:

$$2\pi B\tau = \pi / \ln \left| \frac{1}{r} \right|$$

where B is the absolute bandwidth.

This relationship is shown in Fig.3-35.

According to Bode, the area below the curve is given by the time constant. If r is less than 1 in the stop-bands, and varies in the pass-band, then the maximum value of r in the pass-band will be higher than the theoretical value.

For example, suppose the maximum acceptable VSWR in the pass-band is 1.25, then $r = 0.111$. For the ideal case, this gives: $2\pi B\tau = 1.43$; in practice, $2\pi B\tau$ will rarely exceed 1.0, and then only by a very small amount.

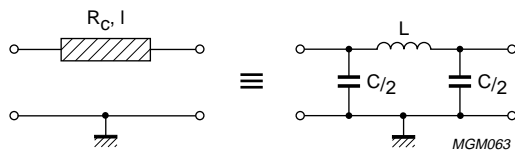

Fig.3-34 LC equivalent circuit of a transmission line shorter than 1/8th of a wavelength.

3.2.2.5 THE UPPER UHF RANGE

Here, we shall consider wideband circuits for TV bands IV and V, covering 470 to 860 MHz, i.e. a bandwidth of 390 MHz.

In Section 3.2.2.3 (Upper VHF range), we described how to match two widely different resistances over a wide range of frequencies. For two pure resistances, matching is always possible, though more sections are required as

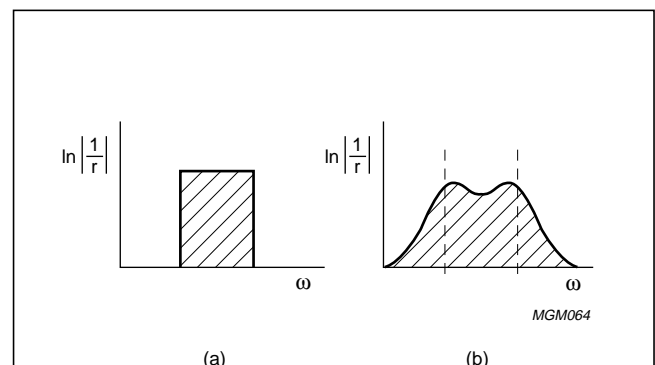

Fig.3-35 (a) Ideal and (b) practical plot of $\ln \left| \frac{1}{r} \right|$ as a function of ω (i.e. 2π times the frequency).

RF transmitting transistor and power amplifier fundamentals

Power amplifier design

3.2.2.5.1 OUTPUT NETWORKS

As an example, take the BLW98, a class-A TV-transposer transistor for bands IV/V (bandwidth, $B = 390$ MHz). At $V_{CE} = 25$ V and $I_C = 0.85$ A, a BLW98 is able to deliver about 4 W peak sync power with a 3-tone intermodulation distortion of -60 dB. Under these conditions, the effective output capacitance, C_C , is ~ 20 pF, and the optimum load resistance in class-A operation is $\sim 20 \Omega$. So the time constant, τ , of the transistor output is ~ 400 ps, and $2\pi B\tau$ then becomes 0.98, meaning that the required bandwidth can just be realized without serious concessions in output power and IMD in parts of the frequency band.

The equivalent output circuit of a transistor without internal output matching is shown in Fig.3-36.

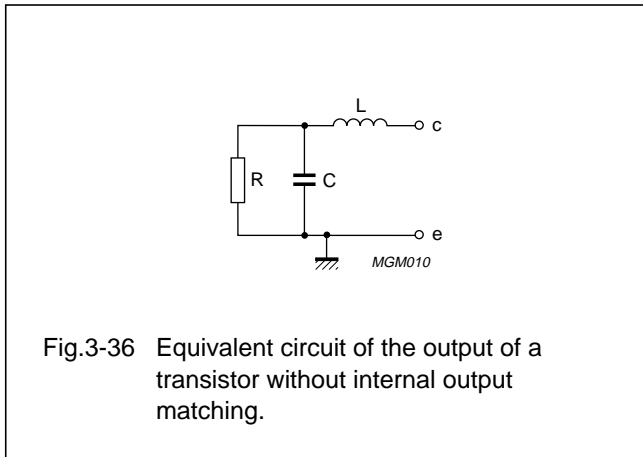

Fig.3-36 Equivalent circuit of the output of a transistor without internal output matching.

The values of R, C and L can be derived from the published curves for optimum load impedance versus frequency. Here, computer programs for circuit analysis with an optimization facility can be very helpful. A good approximation however can also be made using the following:

R: In class-A amplifiers, $R = NV_{CE}/I_C$ where $N = 0.65$ to 0.80 . In other classes, $R = V_C^2/(2P_o)$ but note that for linear class-AB amplifiers, V_C must be chosen 10 to 15% below the supply voltage.

C: In the HF and VHF range, $C = NC_C$ where $N = 1.10$ to 1.15 . In the UHF range (especially in the upper part), higher efficiency and gain can be obtained when the output capacitance is not completely tuned out. In practice, an amount $\Delta C = 0.5/(\omega_m R)$ may be subtracted where ω_m is the maximum angular frequency of the band.

L: This is approximately $L_c + L_e/2$ (about 1 to 2 nH in practice) where L_c and L_e are respectively the collector and emitter self-inductance.

The next step is to choose the configuration of the matching network. Where a large bandwidth is required, as in this example, it can be a big advantage to make the collector RF choke part of the matching network. This can be arranged in two ways. The simplest is where the collector RF choke tunes out the imaginary part of the output impedance in the middle of the band. A better and theoretically more correct method is to apply a Norton transformation as shown in Fig.3-37.

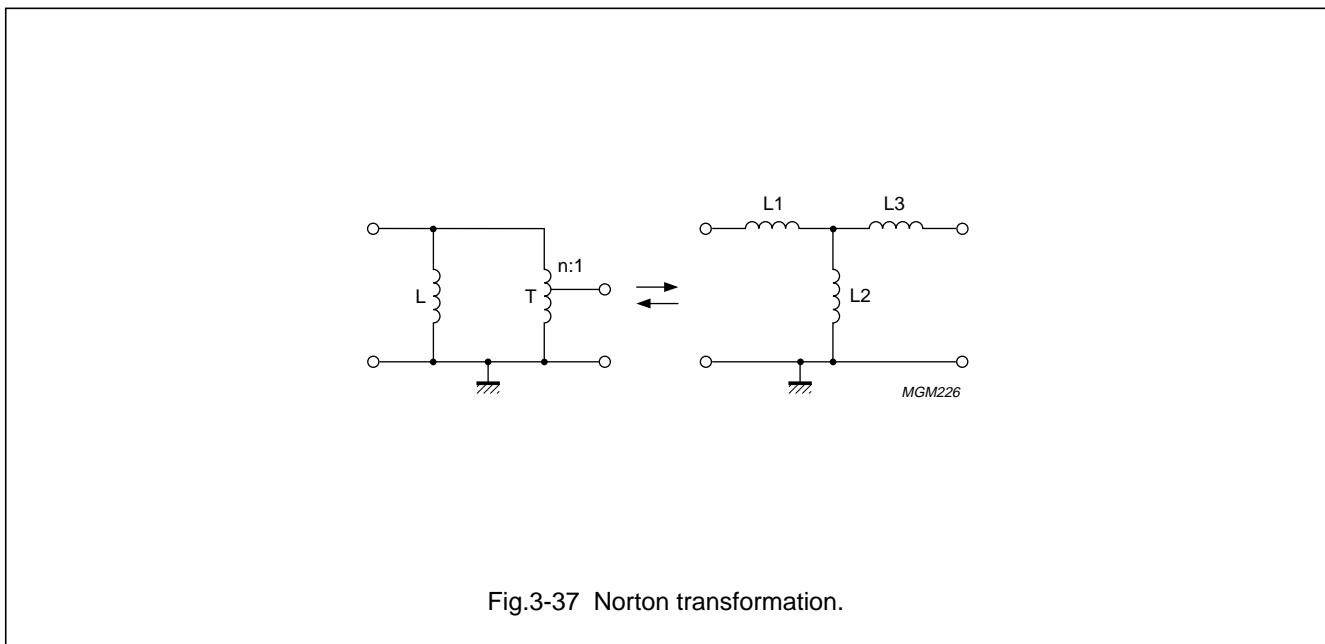

Fig.3-37 Norton transformation.

RF transmitting transistor and power amplifier fundamentals

Power amplifier design

T is an ideal transformer which transforms the voltage down by a factor n ($n > 1$). 'Ideal' means the transformer has no parallel and no stray inductance, i.e. there is 100% coupling between the windings.

The other quantities are:

$$L_1 = L \left(1 - \frac{1}{n} \right)$$

$$L_2 = \frac{L}{n}$$

$$L_3 = \frac{-L(n-1)}{n^2}$$

Note, L_3 is negative but this is subsequently 'absorbed' in the remainder of the network. $L_1 \geq L$ in the equivalent output circuit (Fig.3-36) of the transistor.

Combining Figs 3-36 and 3-37 yields Fig.3-38. So, the transistor output impedance becomes a parallel connection of R' , C' and L' where:

$$R' = \frac{R}{n^2}$$

$$C' = Cn^2$$

$$L' = \frac{L}{n^2}$$

Now we can arrange that the LC-parallel circuit resonates in the middle of the frequency band. Furthermore, we can vary R' within certain limits.

At the 50 Ω side, the same kind of transformation in reverse can be made if required. In this case, a capacitive transformation is also possible, see Fig.3-39 where:

$$C_1 = \frac{-n^2 C}{n-1}$$

$$C_2 = nC$$

$$C_3 = \frac{nC}{n-1}$$

Here, C_1 is negative and so it has also to be absorbed in the remainder of the network.

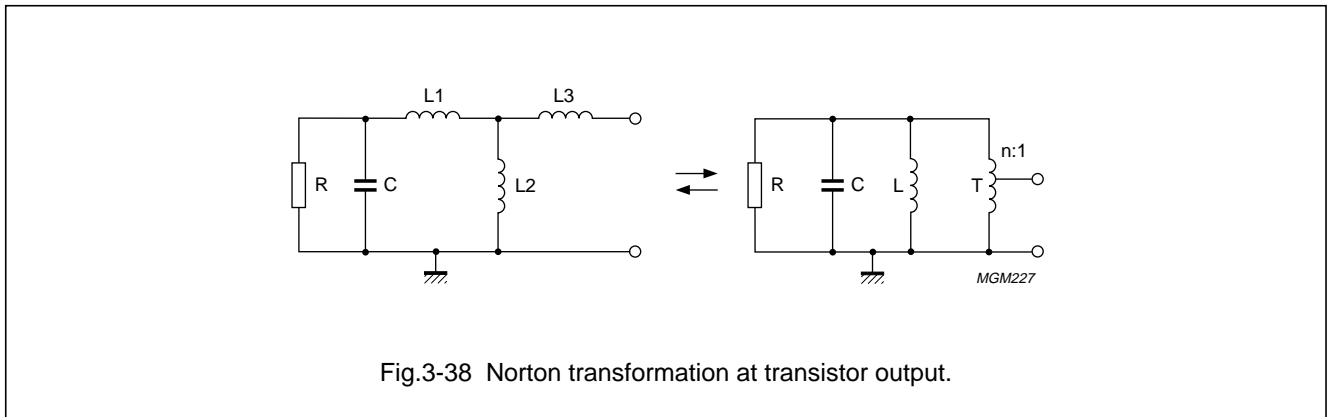

Fig.3-38 Norton transformation at transistor output.

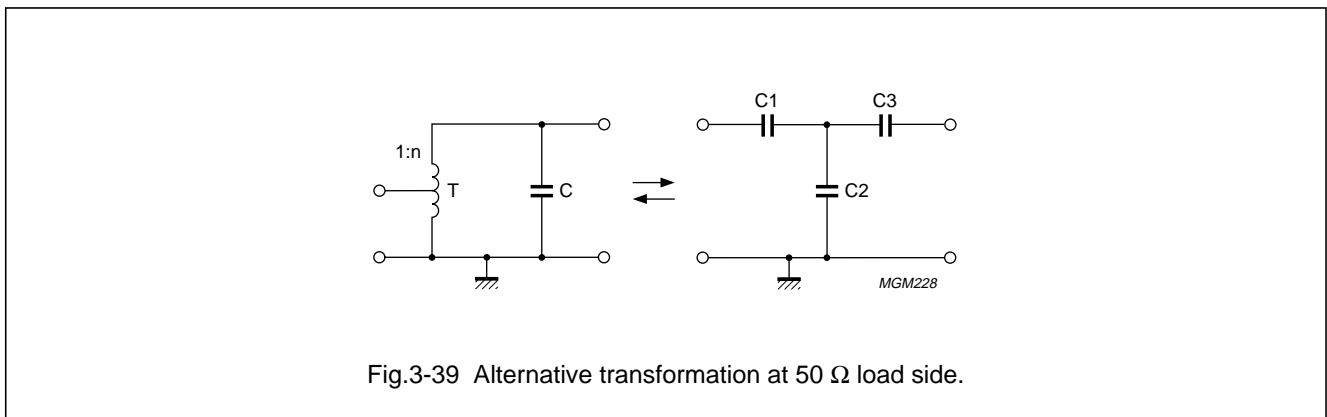

Fig.3-39 Alternative transformation at 50 Ω load side.

RF transmitting transistor and power amplifier fundamentals

Power amplifier design

Sometimes a Pi-equivalent is needed instead of a T-equivalent. This can be obtained as indicated in Fig.3-40 for the capacitive case where:

$$B_{12} = \frac{B}{n}$$

$$B_{20} = B \left(1 - \frac{1}{n} \right)$$

$$B_{10} = \frac{-B(n-1)}{n^2}$$

This transformation also has an inductive equivalent in which $B = -1/\omega L$ instead of ωC .

Now we return to Fig.3-38 to complete the impedance matching. Several methods are possible:

- The Matthaei method as described in Section 3.2.2.3.2
- The Fleischmann method as described in Section 3.2.2.3.2
- A band-pass network as depicted in Fig.3-41.

The network of Fig.3-41 can only be used if R_1 does not differ too much from R_3 , say $2R_3 \geq R_1 \geq R_3/2$. If so, we can apply the Norton transformation (just discussed) at the input and, if necessary, also at the output.

This band-pass network has been derived from an equivalent low-pass Chebyshev filter as shown in Fig.3-42.

Components with the same identifiers (in Figs 3-41 and 3-42) have the same values. Components L_1 , C_2 and L_3 , added in the band-pass network, resonate with the parallel or series-connected components at the geometric mean frequency of the passband, f_0 :

$$f_0 = \sqrt{f_1 f_2}$$

where f_1 and f_2 are the lower and upper limits of the pass-band respectively.

L_1 resonates with C_1 ; C_2 resonates with L_2 , and L_3 resonates with C_3

In Fig.3-42, without a Norton transformation:

$$R_1 = R_3$$

$$C_1 = C_3.$$

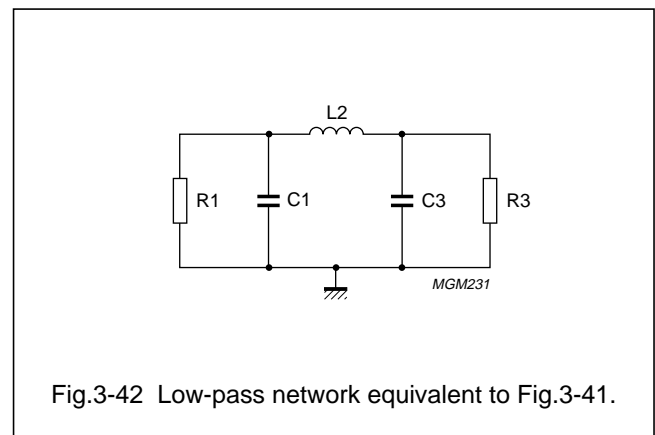
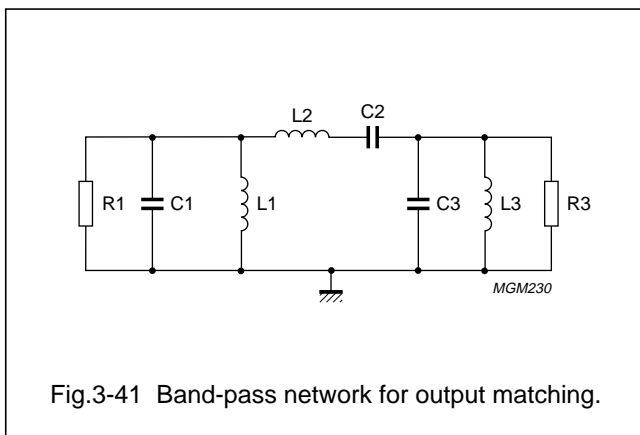
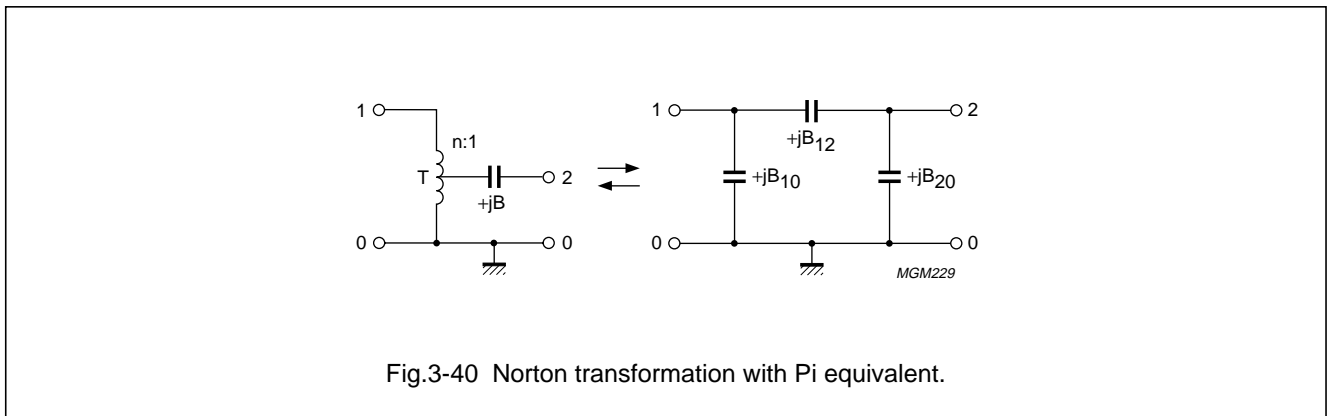

RF transmitting transistor and power amplifier fundamentals

Power amplifier design

By combining some equations from the two-element compensation of Section 3.2.2.1.1, we can express L_2 as:

$$L_2 = \frac{8R_1^2 C_1}{3(\omega C_1 R_1)^2 + 4}$$

where ω is 2π times the required bandwidth. The maximum VSWR of this network can be calculated in the same way as in Section 3.2.2.1.1 where:

$$\gamma = \frac{1}{\omega R_1 C_1}$$

and

$$k = \gamma + \sqrt{\gamma^2 + 1}$$

from which

$$\text{VSWR} = \left(\frac{k^3 + 1}{k^3 - 1} \right)^2$$

Since the Norton transformation does not change the product $R_1 C_1$, this product is the same as that of the equivalent circuit of the transistor output (Fig.3-36). A circuit like that of Fig.3-41, plus transformations, has been made for the BLW32 with $R = 82 \Omega$ and $C = 4.2 \text{ pF}$. With a bandwidth of 390 MHz this gives:

$$\omega RC = 0.8439$$

$$\gamma = 1.185$$

$$k = 2.735$$

$$\text{VSWR} = 1.216.$$

This is very acceptable performance. In practice, the inductances are replaced by striplines as described in Section 3.2.2.4. Re-optimization is then required and the final VSWR will be somewhat higher because of the capacitance of the striplines and the inductance of the SMD chip capacitors. See also application report "ECO7806".

If the Matthaei or Fleischmann method is used instead of the one above, note that:

- For TV band IV/V, three sections (instead of two) may be necessary
- Besides several low-pass elements, sufficient high-pass elements are used. The former are the series inductances and parallel capacitances; the latter are the parallel inductances and series capacitances.

This is necessary to meet, as far as possible, the conditions for the lowest possible reflection coefficient in the pass-band according to the Bode integral. So, three

low-pass sections are not as good as two low-pass plus one high-pass section.

3.2.2.5.2 INPUT NETWORKS

What is desired at the input is a network that gives good impedance matching over the entire frequency band while compensating for the variations in transistor gain with frequency. The overall gain (transistor plus network) should be roughly equal to the transistor gain at the highest frequency of the band.

For low powers, as in driver stages, this can be realized with a network containing one or two resistors. For high powers, there are better solutions, namely:

1. Make a network giving good impedance matching over the frequency band, and compensate the gain variation somewhere else in the amplifier chain or,
2. Make a network giving an (almost) exact match at the highest frequency of the pass-band and increasing mismatch at lower frequencies such that the increasing gain of the transistor is compensated in the best possible way.

The second approach is much easier to realize because the loaded Q-factors in the network may be higher than with the first approach.

Assuming a gain variation of the transistor of 6 dB per octave, the input VSWR at the lowest frequency of TV bands IV and V will be 11.3 if the second method is followed. Clearly, the preceding amplifier stage cannot function normally under these conditions. Fortunately, there is a simple solution to this problem - make two identical amplifier stages according to this principle and combine them with 3 dB, 90° hybrid couplers as shown in Fig.3-43.

The first hybrid coupler splits the drive power delivered at port 1 into two equal parts at ports 2 and 3, and introduces a 90° phase shift between the two signals. If ports 2 and 3 are loaded with 50Ω , the output at port 4 is zero.

The most important property of a 90° hybrid coupler is that equal amounts of mismatch at ports 2 and 3 do not influence the matching at port 1; any reflected power goes to port 4. The mismatch at ports 2 and 3 must however be equal in amplitude and phase.

At the second coupler, the opposite happens. For two input signals of equal amplitude and 90° phase difference, the output is the sum of the powers while the power at port 4 is again zero. If the powers are not equal or the phase difference deviates from 90° , then the power difference appears on port 4.

RF transmitting transistor and power amplifier fundamentals

Power amplifier design

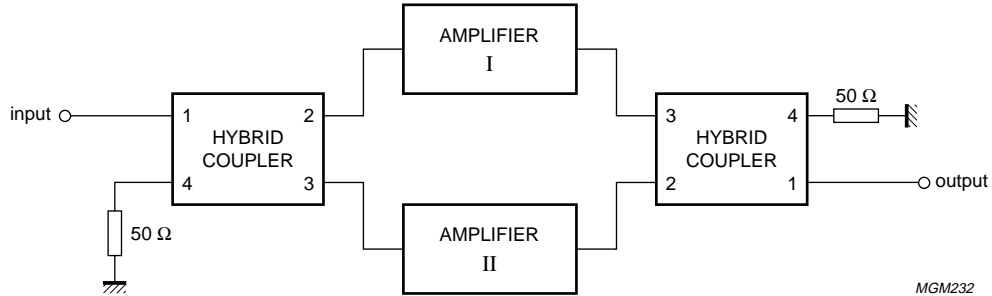

Fig.3-43 Input/output network using two identical amplifiers and 90° hybrid couplers to lower VSWR.

This sort of hybrid coupler with a full octave bandwidth and continuous power handling of 200 W is available from Anaren, USA.

Another American company, Sage, delivers the Wireline. This is a special semi-rigid coaxial cable with two inner conductors. A hybrid coupler is formed from a $1/4 \lambda$ cable for the middle of the frequency band. Note, the wavelength in this cable is about two-thirds that in free space. The Wireline is available in several thicknesses to suit different power requirements. For high powers, another product with a square cross-section is available (Wirepack).

If the bandwidth requirements are less severe, 90° hybrid couplers can be made from striplines as shown in Fig.3-44. Here, four striplines of $1/4 \lambda$ and characteristic resistances of 50 and 35.4 Ω are used. In a practical implementation, it is usual to:

- Replace the striplines by LC equivalents see Fig.3-45, or
- Make the hybrid coupler with shortened striplines, and add compensation (multilayer SMD) capacitors, see Fig.3-46.

In Fig.3-46, let $\tan \beta l = t$ then:

$$R'_c = R_c \sqrt{\frac{1+t^2}{t^2}}$$

$$X_c = R_c \sqrt{1+t^2}$$

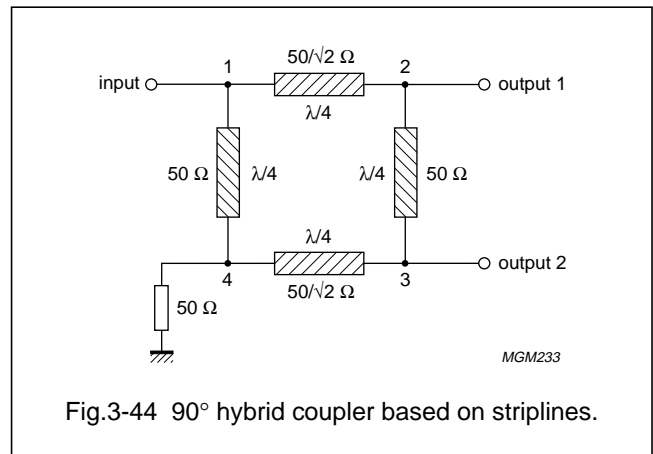

Fig.3-44 90° hybrid coupler based on striplines.

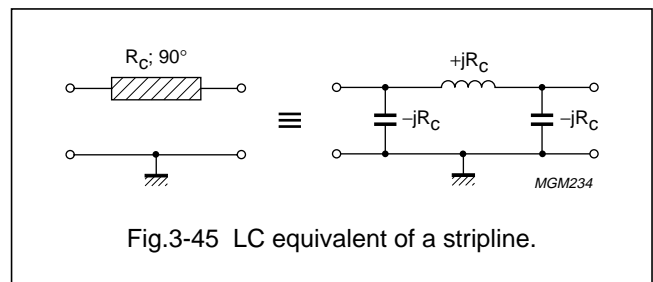

Fig.3-45 LC equivalent of a stripline.

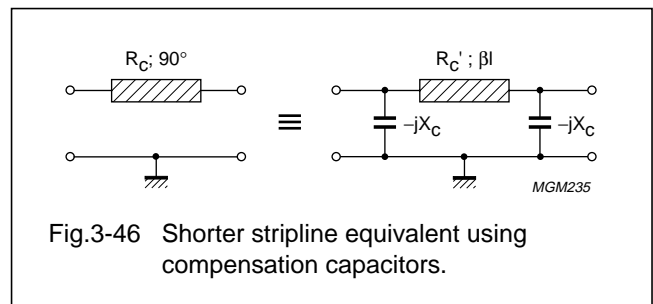

Fig.3-46 Shorter stripline equivalent using compensation capacitors.

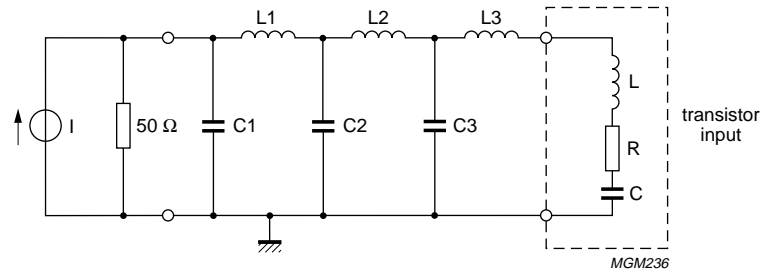

Fig.3-47 Typical input matching network.

Procedure for designing an input matching network

When calculating input matching networks, it is useful to know the RLC series-equivalent of the transistor input impedance. A first estimate can be made on the basis of the published graph of input impedance versus frequency. More accurate estimates can be obtained with the aid of a circuit analysis computer program.

To design an input matching network meeting the conditions mentioned earlier, use the following procedure, see Fig.3-47.

The last section (L_3 - C_3) is designed for the highest frequency of the band. For bipolar transistors, the value of C is so high that it has no practical influence. The best value for the loaded Q-factor in this case is then about 4, and the resistance R is transformed up by a factor $Q^2 + 1$, so about 17 times.

For MOS transistors, a lower loaded Q-factor is required because of the relatively smaller value of C . A good value for Q is 2 to 3. The resistance R is then transformed up by a factor of 5 to 10, resulting in a sufficiently flat power gain.

The remaining sections, L_1 - C_1 and L_2 - C_2 , can be calculated using the Matthaei method for the entire frequency band starting from the value found for R ($Q^2 + 1$) and the 50Ω of the generator.

In the example above, the remaining part of the matching used two sections. In some cases, one is sufficient, but this depends on the value of R . The lower this is the more sections are required.

3.2.3 Interstage networks

Impedance matching networks between successive stages can be designed in the same way as discussed in the previous sections. For narrow-band amplifiers, this can

be done directly (i.e. with no intermediate 50Ω impedance level). However, for wideband amplifiers it is very useful to choose an intermediate impedance of 50Ω to facilitate the alignment of the amplifier. The best way to align the output part of the network is by means of a dummy load. We shall return to this later in Section 3.5.1.

3.3 Guidelines for choosing print boards and components

3.3.1 Print board materials

Two main print board materials are used for constructing test circuits and practical RF power amplifiers: epoxy fibreglass and Teflon fibreglass.

3.3.1.1 EPOXY FIBREGLASS

The relative dielectric constant (ϵ_r) of this material can vary between 4 and 5; the average, 4.5, is suitable for most calculations. The material is available in several thicknesses, the most popular being: 1/16 inch (~1.6 mm) and 1/32 inch (~0.8 mm). The copper thickness commonly used is called 1 oz. which corresponds to a thickness of ~38 μm .

The dielectric loss factor of epoxy fibreglass is rather poor ($\tan \delta = 0.030$ to 0.035). This means a capacitor formed from part of the board itself has an unloaded Q-factor of only about 30, limiting this type of board to HF and VHF circuits. The board can however be used for interconnecting components and making low-impedance striplines.

Sometimes, even an interconnection area can cause problems. Take for instance point A in the circuits of Section 3.2.1.2. Suppose that the area of this connection is 1 cm^2 and the board thickness is 1.6 mm, then the capacitance will be about 3.35 pF. At 175 MHz and a Q_0 of 30, the parallel resistance will therefore be 8150Ω .

RF transmitting transistor and power amplifier fundamentals

Power amplifier design

If the transistor operates at a supply voltage of 28 V say, and the coil in the matching network has a loaded Q of 5, the voltage at point A is 140 V maximum and the power loss in this connection area is approximately 1.2 W. This is already on the high side and, when the supply voltage and/or the loaded Q are higher, it can be considerably more. A good remedy in such a case is to remove the copper on the bottom side of the board beneath the connection area, and also to remove some heatsink material in the same region.

3.3.1.2 TEFLON FIBREGLASS

Another popular material is Rogers RT/duroid with an ϵ_r of 2.2. This material can be obtained in the same dielectric and copper thicknesses as epoxy fibreglass. The losses are considerably lower ($\tan \delta = 0.001$ to 0.002), making it very suitable for UHF circuits with striplines.

Tables 3-7 and 3-8 show the relationship between the characteristic resistance of stripline, R_c , and its width, w , for 1/16 inch and 1/32 inch board thicknesses. The table data have been generated by computer program based on information in Ref.8. The quantity SQRT ϵ_r is the line shortening factor by which the stripline length with air as a dielectric must be divided to obtain the line length on the print board. In addition, the inductance and capacitance per mm line length are given.

Table 3-7 Some characteristics of 1/16" (1.575 mm) Teflon fibreglass (Rogers RT-duroid)

W (mm)	R_c (Ω)	SQRT ϵ_r	L/I (nH/mm)	C/I (pF/mm)
4.746	50.00	1.367	0.22783	0.09113
1.000	113.23	1.313	0.49574	0.03866
1.500	95.47	1.325	0.42157	0.04625
2.000	83.15	1.334	0.36970	0.05348
2.500	73.90	1.342	0.33054	0.06052
3.000	66.64	1.349	0.29960	0.06745
3.500	60.77	1.355	0.27439	0.07431
4.000	55.90	1.360	0.25341	0.08110
4.500	51.79	1.365	0.23562	0.08785
5.000	48.28	1.369	0.22034	0.09454
5.500	45.23	1.373	0.20705	0.10120
6.000	42.57	1.377	0.19538	0.10782

$\epsilon_r = 2.200$; $H = 1.575$ mm; $Th = 0.0350$ mm.

Table 3-8 Some characteristics of 1/32" (0.787 mm) Teflon fibreglass (Rogers RT-duroid)

W (mm)	R_c (Ω)	SQRT ϵ_r	L/I (nH/mm)	C/I (pF/mm)
2.352	50.00	1.364	0.22739	0.09095
1.000	82.31	1.330	0.36492	0.05386
1.500	66.12	1.346	0.29656	0.06783
2.000	55.53	1.357	0.25127	0.08148
2.500	48.00	1.367	0.21874	0.09493
3.000	42.36	1.375	0.19413	0.10820
3.500	37.95	1.382	0.17480	0.12135
4.000	34.42	1.388	0.15917	0.13439
4.500	31.51	1.393	0.14626	0.14733
5.000	29.07	1.397	0.13538	0.16021
5.500	26.99	1.401	0.12608	0.17302
6.000	25.21	1.405	0.11804	0.18578

$\epsilon_r = 2.200$; $H = 0.787$ mm; $Th = 0.0350$ mm.

The main function of a stripline in a circuit is to provide a particular inductance. As a narrow, short line can have the same inductance as a wide, long one, see Tables 3-7 and 3-8, a choice has to be made based on power handling. The reactive power, i.e. the volt-ampere product, that the line is required to handle must be taken into account, i.e.:

$$P\beta I (s + 1/s)$$

where:

P is the power transferred

βI is the electrical line length in radians

s is the voltage standing wave ratio.

Dividing this product by the unloaded Q-factor of the line, (usually 200 - 400) gives the power lost in the line.

A collector or drain RF choke can also be made in the form of a stripline. The reactance of a line RF 'short circuited' at one end is:

$$X = R_c \tan(\beta I).$$

And, the volt-ampere product of such a line is:

$$V^2 \beta I / \{R_c \sin^2(\beta I)\}$$

where:

V is the RMS value of the RF voltage at the end not 'short-circuited'

βI is again the electrical line length in radians.

RF transmitting transistor and power amplifier fundamentals

Power amplifier design

3.3.2 Choice of components

3.3.2.1 INDUCTORS

Depending on the value of the inductance required, inductors can be made in the form of a length of wire or a coil having one or more turns:

- straight wire

The inductance of a straight wire is:

$$L = 0.46 l \log(1.47 l/d) \text{ nH.}$$

where l is the length of the wire and d the diameter, both in mm.

- single turn coil

The inductance of a single turn of wire is:

$$L = 1.44D \log(1.08 D/d) \text{ nH.}$$

where:

D is the diameter (wire centre to wire centre) of the turn and d the wire diameter, both in mm.

- multi-turn coil

The inductance of a coil with more than one turn wound in a single layer is:

$$L = n^2 D^2 / \{1.013 (l + 0.45D)\} \text{ nH}$$

where:

n is the number of turns

D is the diameter (wire centre to wire centre) of the coil in mm

l is the length of the winding in mm.

The accuracy of the last formula is better than 1% provided $l > 0.45D$.

The formulae above indicate that the same inductance can be realized in different ways. An important point is the choice of the wire diameter. And, as a guideline, it is recommended to limit the current density to 2 to 3 A/mm². Although this guideline stems from the design of AF transformers and chokes where the windings are packed tightly together, it is relevant for inductances used at RF, as the series resistance due to skin-effect at high frequencies will be considerably greater.

Another point to consider for single layer coils is the ratio of the length of the winding to the diameter of the coil. The best ratio is 1 to 2 to get a high unloaded Q-factor. Providing some spacing between the turns will improve this Q-factor, and the recommended spacing is equal to the wire diameter.

3.3.2.2 FIXED CAPACITORS

The most important properties of a capacitor for use in matching networks at high frequencies are:

- Maximum operating voltage
- Unloaded Q-factor
- Series inductance
- Size (in relation to dissipation)
- Temperature coefficient.

Nowadays, ceramic multilayer SMD capacitors (chip capacitors) are widely used, these having largely superseded leaded cylindrical and rectangular ceramic types. The Philips multilayer range contains Class 1, NPO types in different sizes and with maximum operating voltages up to 500 V (Ref.9). Class 1 means a relatively low ϵ_r and $\tan \delta$. NPO denotes a low temperature coefficient. Whilst these capacitors are suitable for many applications, a capacitor meeting more stringent specifications may be required in some applications.

The series inductance of most chip capacitors is about 1 nH. The VA-product that a chip can handle can be estimated as follows. Suppose a (small) chip can dissipate 300 mW and the unloaded Q-factor is 300, then the VA-product is the product of these two quantities:

$$VI = 0.3 \times 300 = 90 \text{ VA}$$

If a specific application requires a higher VA-product, a parallel and/or series combination of chips can be used.

3.3.2.3 TRIMMERS

For VHF and UHF circuits, there are some excellent trimmers with Teflon isolation in Philips' product program (e.g. the 809 series, Ref.9). These have maximum operating voltages of 200 to 300 V, a maximum operating temperature of 125 °C and a guaranteed unloaded Q-factor between 400 and 670 at 100 MHz. They can be used up to about 1 GHz (their series inductance is 5 to 8 nH). At higher frequencies, products such as 'Gigahertz Trimmer Capacitors' from Tekelec (Johansson) are suitable. These have a self-resonant frequency well above the frequency of operation.

The power handling of these trimmers is much higher than that of chip capacitors. Some reserve is desirable because of the higher series inductance of trimmers. Parallel connection with chip capacitors is recommended to optimize the size of the control range.

RF transmitting transistor and power amplifier fundamentals

Power amplifier design

3.4 Amplifier configurations

Most RF power amplifiers are 'single-ended', i.e. they have one power transistor. Sometimes, however, there are good reasons for using amplifiers having two or more transistors, as for example described in Section 3.2.2.5.2. In such cases, there are several ways to interconnect the transistors, the most popular employing:

- Hybrid couplers (90° phase difference)
- Parallel connection (0° phase difference), or
- Push-pull or balanced connection (180° phase difference).

3.4.1 Hybrid couplers

The use of hybrid couplers has already been described in the wider discussion of input networks in Section 3.2.2.5.2 just referred to. There, two single-ended stages were combined using 3 dB, 90° hybrid couplers to provide impedance matching and a flat power gain over a wide band of frequencies. The reader is referred back to that section for further details.

3.4.2 Parallel connection

3.4.2.1 VHF AND UHF RANGES

Sometimes, in base stations for mobile radio, output powers higher than those that can be delivered by a single transistor are required. The simplest solution is then to connect two transistors in parallel. However, because the transistor impedances can be very low, it is not recommended that this be done directly (i.e. by connecting gate-to-gate and drain-to-drain). A better method is shown in Fig.3-48.

Adjacent the transistors, separate matching sections are used; elsewhere, the sections are common to both transistors.

Resistors R_1 and R_2 are included to prevent push-pull oscillations, and perform the function of a hybrid coupler. Although this circuit does not fully isolate the transistors, it does prevent oscillations. For the best performance, R_1 should be twice the equivalent parallel input resistance and R_2 twice the load resistance of one transistor.

In Fig.3-48, only the RF components are shown. DC components such as RF chokes, coupling and decoupling capacitors still have to be added.

3.4.2.2 HF RANGE

Another form of parallel connection is often used in high-power amplifiers for the HF range. An extensive description of such a system is given in application report "AN98032". The combining transformer (transmission line type) used is also described in report number "ECO6907".

3.4.3 Push-pull (balanced) connection

To obtain more power than that obtainable from a single transistor, two transistors can be operated in push-pull mode (i.e. with 180° phase difference). To assist designers, several dual transistors already configured for push-pull are available from Philips. MOS and bipolar types for VHF and UHF operation are available.

The main advantage of push-pull is the good suppression of even-order harmonics and intermodulation products, simplifying the design of harmonic filters. It is therefore used extensively in HF SSB transmitters, as well as in FM broadcast and TV bands III, IV and V.

In the HF range, baluns (balanced to unbalanced transformers) can usually be combined with the required impedance transformation. This is done with transmission line or conventional transformers with ferrite cores as described in application reports "ECO6907" and "ECO7213".

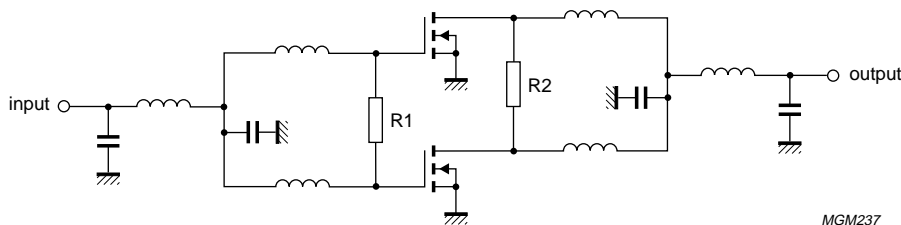

Fig.3-48 Two-transistor power amplifier with matching sections. This arrangement is also suitable for bipolar transistors.

RF transmitting transistor and power amplifier fundamentals

Power amplifier design

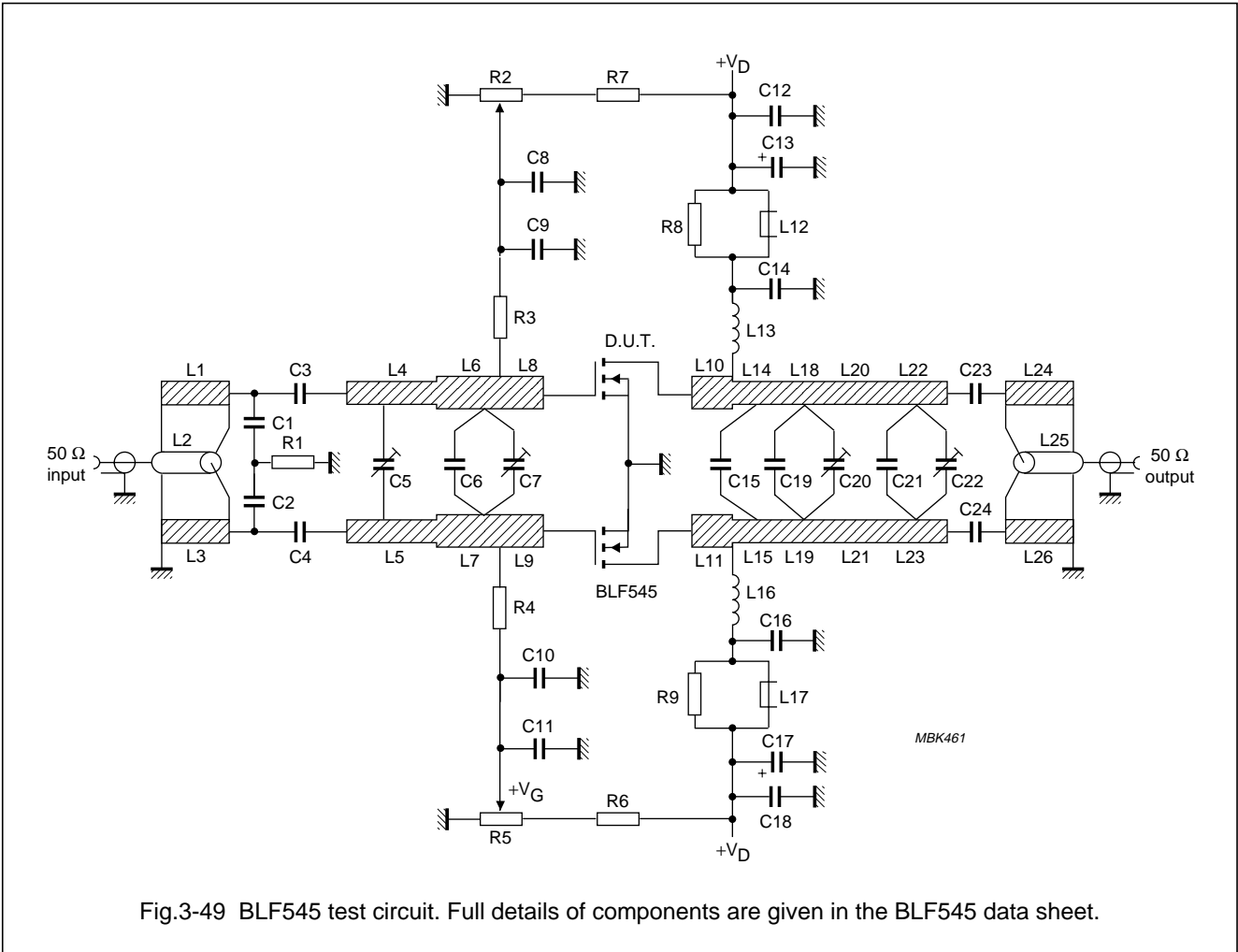

Fig.3-49 BLF545 test circuit. Full details of components are given in the BLF545 data sheet.

In the VHF and UHF ranges, another kind of balun is often used. Take, for example, the 500 MHz test circuit of the BLF545 (Fig.3-49). Although this is a narrow-band circuit, the balun used is a wideband type with a bandwidth of approximately one octave. Note that owing to the operating frequency, extensive use is made of striplines.

The baluns are both at the input (L₁, L₂ and L₃) and at the output (L₂₄, L₂₅ and L₂₆). The input balun splits the signal on a 50 Ω basis (asymmetrical) into two signals in antiphase, each of half the input power. At the output, the reverse takes place.

A very convenient way of realizing this is by means of a semi-rigid coax cable with a characteristic resistance of 50 Ω. Looking at the output balun in Fig.3-49, we see that this is L₂₅ and that its outer conductor is grounded at the output side while at the input side of this cable, both the inner and outer conductors are floating.

The best isolation will be obtained if the cable length (inner and outer conductors) is 1/4 λ for the centre of the frequency band (500 MHz). A disadvantage however is the impractical length of the cable.

A better solution is to use a cable length of about 1/8 λ soldered on top of a print track of the same length. The track width must of course be somewhat larger than the cable diameter so the two can be soldered together.

The signal that reaches the outer conductor of the cable via C₂₄ is now shunted by a short stripline with an R_c of about 48 Ω and 1/8 λ long. The reactance of this stripline is then:

$$X_p = R_c \tan \beta l = 48 \tan 45^\circ = 48 \Omega$$

To restore the symmetry, we have to shunt the other signal, reaching the inner conductor of the cable via C₂₃ with a stripline of the same dimensions, as shown in Fig.3-50.

RF transmitting transistor and power amplifier fundamentals

Power amplifier design

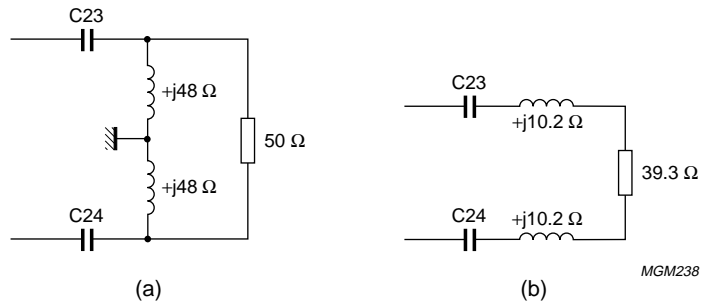

Fig.3-50 (a) Modified output baluns using $1/8 \lambda$ stripline; (b) Transformed circuit of (a) using the parallel-to-series transformation described in Section 3.2.1.1.

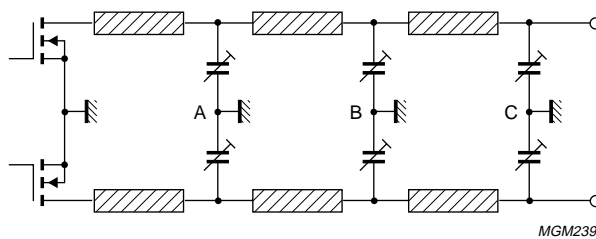

Fig.3-51 Output matching of a push-pull amplifier.

The last step is to choose the reactances of the capacitors C_{23} and C_{24} which have to be equal to the series-equivalent inductive reactances.

The result is that we have transformed the asymmetrical load resistance of 50Ω to a symmetrical and real load resistance with a somewhat lower value. The latter is not a real problem as in many cases the transistor load impedance is lower still, so the balun forms part of the matching network.

In principle, the matching can be made for each section of the push-pull transistor separately as in Fig.3-51. However, it is not necessary to ground points A, B and C, so two capacitors in series can then be replaced by one of half the value, simplifying the circuit.

If the transistor operates in push-pull mode, it sees at its input the correct source impedance and at its output the correct load impedance. When analysing such a circuit in

the parallel mode, it appears that in most cases the abovementioned conditions are not met at all. Both the input and the output circuits are practically unloaded so a parallel mode of oscillation (as opposed to the normal push-pull oscillation) can easily occur at a frequency far below the operating frequency. A good remedy is to introduce damping at the input and/or the output for this parallel mode which has no influence on the push-pull operation. An example is the combination $C_1-C_2-R_1$ in the BLF545 test circuit (Fig.3-49).

Another possibility is to shift the resonant frequency in the parallel mode by a large amount. This can be done for example at the input by not soldering the coax cable L_2 on L_1 but by loading it with a ferrite tube or several beads.

L_2 can also be wound on a ferrite toroid. The tracks L_1 and L_3 then become superfluous and the values of capacitors C_3 and C_4 must be increased as they now have only the function of coupling capacitors. Suitable grades of

RF transmitting transistor and power amplifier fundamentals

Power amplifier design

ferrite are 4B and 4C. If a toroid is used, the inductance of the outer conductor of L_2 will be increased considerably. And although this inductance has a relatively large loss factor in the VHF/UHF range, if the impedance is high enough then the gain loss is rather small. An example of this method can be found in the 108 MHz test circuit of the BLF278 (see "Data Handbook SC19a").

Returning to the BLF545 circuit at 500 MHz, we see the input balun compensated differently to the output one. L_1 and L_3 are tuned by the parallel capacitors C_1 and C_2 , so there will be no transformation of the source resistance.

A good example of a wideband push-pull power amplifier using the baluns described above can be found in Application note "AN98014". This amplifier delivers 150 W in TV-band IV/V and uses a BLV862 transistor.

3.5 Miscellaneous

3.5.1 Alignment of RF power amplifiers

In most cases, test circuits are aligned for maximum power gain and minimum input reflection. Sometimes a situation of very high power gain and moderate efficiency arises. This indicates that the circuit is very close to instability. Often, this is because the output network has been aligned in such a way that the transistor is loaded inductively, introducing (via the feedback capacitance) a negative resistance component at the input.

Though extra damping at the input lowers the gain and improves stability, it often does not raise efficiency. In such cases, it is better to align the output network with a dummy load. This procedure is also recommended for linear amplifiers such as those in SSB transmitters and in TV transposers and transmitters where the main aim is to minimize distortion. A dummy load for a 4-lead transistor with a stud or flange envelope can be made using a small piece of printed-circuit board as shown in Fig.3-52.

Between the collector and emitter connections of a bipolar transistor (or between the drain and source connections of a MOS transistor), an SMD resistor and an SMD multilayer capacitor of the correct value are connected in parallel. Together, these components form the complex conjugate value of the optimum load impedance of the transistor. Note, the values of resistor and capacitor for the dummy load can be determined using the guidelines given in Section 3.2.2.5.1.

The dummy load is placed in the circuit instead of the transistor. At the 50 Ω output, a signal generator is connected via a directional coupler to measure the reflection coefficient.

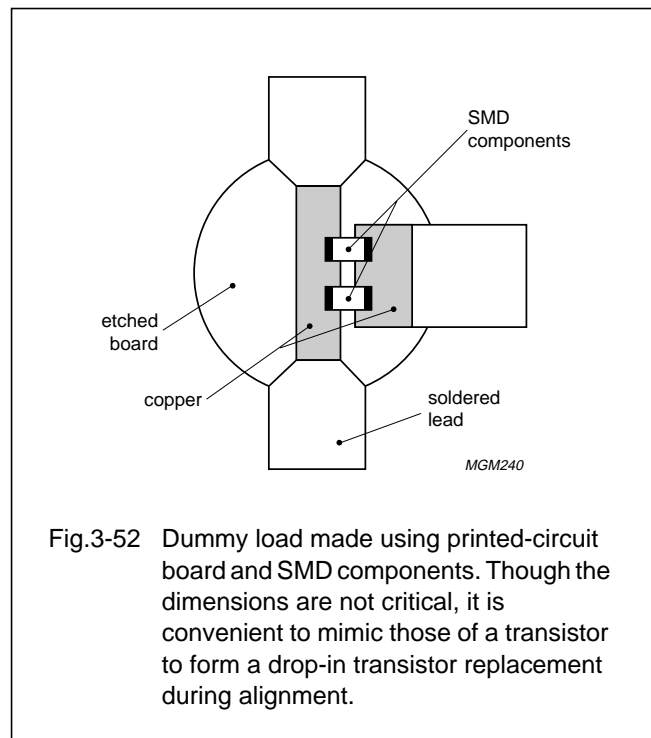

Fig.3-52 Dummy load made using printed-circuit board and SMD components. Though the dimensions are not critical, it is convenient to mimic those of a transistor to form a drop-in transistor replacement during alignment.

The output network is adjusted for zero reflection. After this procedure the network, loaded with 50 Ω , will provide the correct load impedance to the transistor and further alignment is not advised.

For push-pull transistors, the same method can be followed, but with two identical loads on one piece of printed-circuit board.

For wideband amplifiers too, this method is highly recommended. The signal generator has to be of the swept-frequency type, e.g. an R & S Polyskop or HP network analyzer.

For input networks of wideband amplifiers (see Fig.3-53) another method must be followed.

In this amplifier, capacitors C_1 and C_4 are partly variable (they are the parallel connection of a chip capacitor and a trimmer), while C_2 and C_3 are fixed (chip capacitors). The inductances L_2 and L_3 are relatively small and are therefore executed as striplines.

When aligning the output network by means of a dummy load, C_4 can first be varied to get the reflection over the whole frequency band within the required limits. If this is not sufficiently successful, C_3 can be varied in steps until the desired result is obtained. In most cases the results are then satisfactory; sometimes, L_4 must also be involved in this process.

RF transmitting transistor and power amplifier fundamentals

Power amplifier design

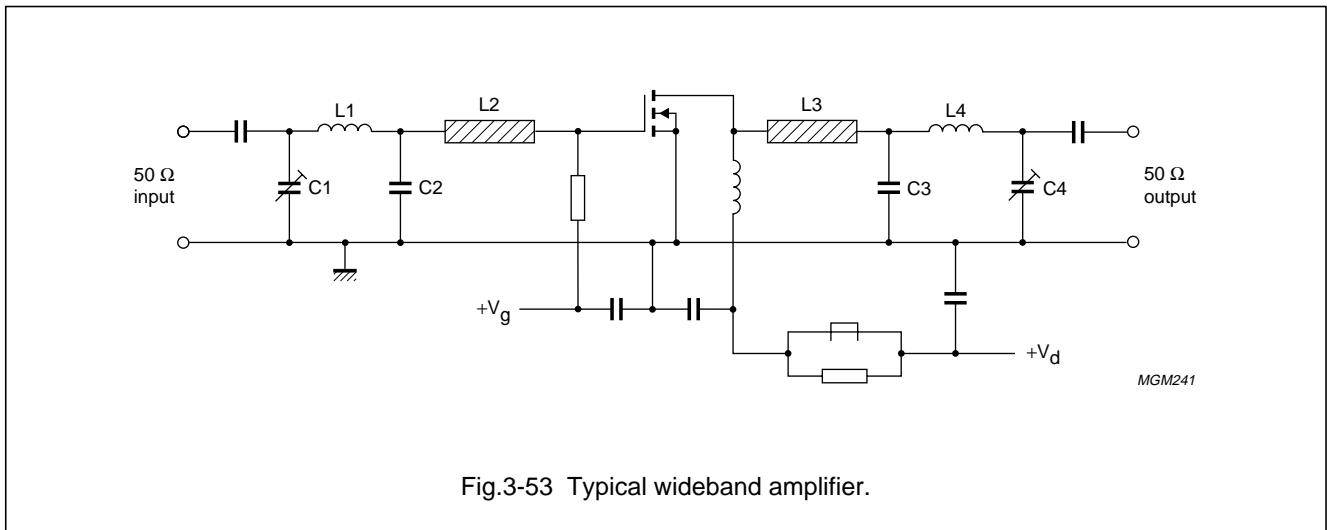

Fig.3-53 Typical wideband amplifier.

To align the input network, the transistor is put into the circuit, the 50 Ω load resistance is connected and the normal supply voltage applied. The bias voltage is adjusted in such a way that the transistor operates in class-A with a dissipation close to the desired output power, see data sheet for suitable values. Subsequently, the input network is aligned for minimum reflection over the desired frequency band. Compared with the output network this must be done in reverse order, namely C_1 first and when this is not sufficient also C_2 , and in the last resort L_1 .

This class-A alignment of the input network, done with small input signals, brings us very close to the final result. The last fine tuning of this network can then take place in the intended class of operation and with normal bias and RF drive powers for the required output power.

3.5.2 Suppression of parasitic oscillations

Oscillations at or near the frequency of operation can occur both with bipolar and MOS transistors especially in the lower VHF region. A suitable damping resistor between base and emitter (or between gate and source) will stop this type of oscillation.

Another type of oscillation occurs mainly with bipolar transistors although under certain circumstances with MOS devices too. This oscillation has to do with the biasing method. The collector or drain RF choke has a much higher inductance than the tuning elements and together with the total capacitance from collector or drain to earth it forms a resonant circuit at a frequency far below the operating one.

Sometimes a similar situation exists at the input side especially with bipolar transistors. If these circuits are not well damped, parasitic oscillation at relatively low frequency can start due to the always present feedback capacitance.

The best remedy is a combination of components giving strong damping at low frequencies and very little damping at the frequency of operation. Generally speaking, transistors should be loaded at both their input and output with a low, mainly resistive impedance. This can be provided at the input side with the circuit of Fig.3-54(a) and at the output side with the circuit of Fig.3-54(b) or (c).

In all these circuits, L_1 is a relatively small inductance with a high Q-factor and a reactance at the operating frequency of 3 to 7 times the equivalent parallel resistance at that point. L_2 is a much higher inductance with a low Q-factor, e.g. a choke with a ferrite core (3B being a good material). The inductance can be 6 to 8 μH .

R is a small resistor, say 10 Ω . C_1 is a decoupling capacitor for the operating frequency, i.e. a low value ceramic type with high Q-factor. C_2 is a much higher capacitance, e.g. 100 nF which can have a low Q-factor.

Sometimes the supply voltage is decoupled with an extra capacitor which can be a low value electrolytic type (not drawn).

Another form of parasitic oscillation is parametric oscillation caused by the non-linear-properties of the collector capacitance. If this capacitor is fully driven by the RF voltage, it can develop a negative resistance at one half and even one third of the RF frequency, leading to instability when the collector or drain RF choke has a very low value.

RF transmitting transistor and power amplifier fundamentals

Power amplifier design

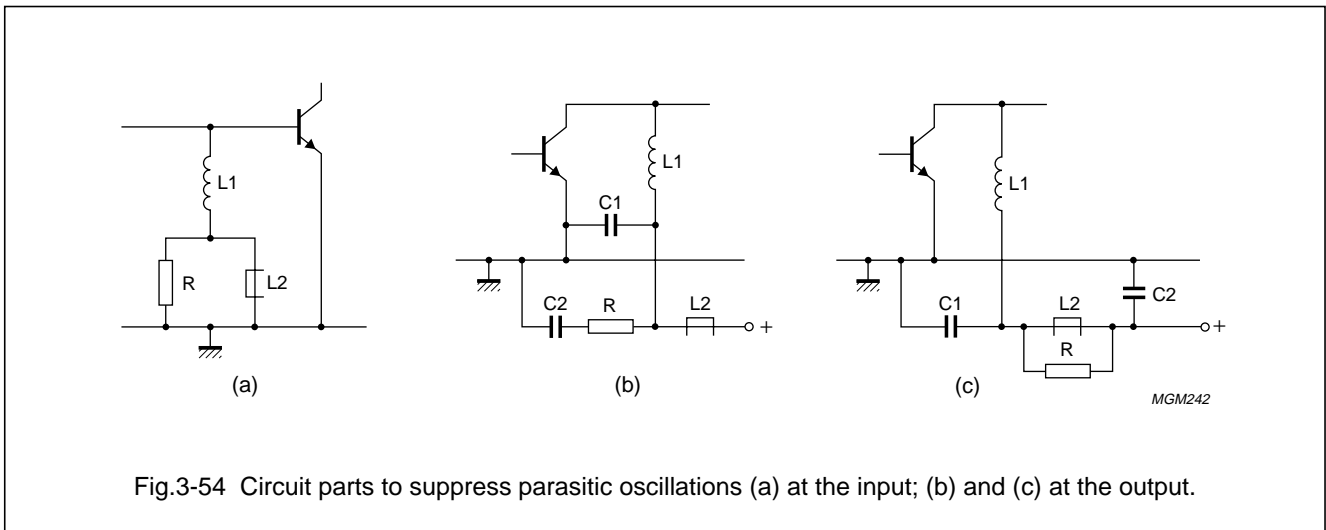

Fig.3-54 Circuit parts to suppress parasitic oscillations (a) at the input; (b) and (c) at the output.

Also possible is a parametric oscillation known as conversion oscillation. This can happen when the collector or drain circuit contains two resonant circuits where the sum of the resonant frequencies equals the frequency of operation. The lower one is then formed by the RF choke and the total effective parallel capacitance while the other is the slightly detuned output matching circuit. This detuning can arise during tuning or by a small antenna mismatch.

Mathematically it can be shown that the power of this oscillation is divided into the ratio of the resonant frequencies of the tuned circuits. Fortunately, the measures necessary to stop this oscillation are the same as those previously mentioned.

SUNSTAR 商斯达实业集团是集研发、生产、工程、销售、代理经销、技术咨询、信息服务等为一体的高科技企业，是专业高科技电子产品生产厂家，是具有 10 多年历史的专业电子元器件供应商，是中国最早和最大的仓储式连锁规模经营大型综合电子零部件代理分销商之一，是一家专业代理和分销世界各大品牌 IC 芯片和电子元器件的连锁经营综合性国际公司，专业经营进口、国产名厂名牌电子元件，型号、种类齐全。在香港、北京、深圳、上海、西安、成都等全国主要电子市场设有直属分公司和产品展示展销窗口门市部专卖店及代理分销商，已在全国范围内建成强大统一的供货和代理分销网络。我们专业代理经销、开发生产电子元器件、集成电路、传感器、微波光电元器件、工控机/DOC/DOM 电子盘、专用电路、单片机开发、MCU/DSP/ARM/FPGA 软件硬件、二极管、三极管、模块等，是您可靠的一站式现货配套供应商、方案提供商、部件功能模块开发配套商。商斯达实业公司拥有庞大的资料库，有数位毕业于著名高校——有中国电子工业摇篮之称的西安电子科技大学（西军电）并长期从事国防尖端科技研究的高级工程师为您精挑细选、量身订做各种高科技电子元器件，并解决各种技术问题。

微波光电部专业代理经销高频、微波、光纤、光电元器件、组件、部件、模块、整机；电磁兼容元器件、材料、设备；微波 CAD、EDA 软件、开发测试仿真工具；微波、光纤仪器仪表。欢迎国外高科技微波、光纤厂商将优秀产品介绍到中国、共同开拓市场。长期大量现货专业批发高频、微波、卫星、光纤、电视、CATV 器件：晶振、VCO、连接器、PIN 开关、变容二极管、开关二极管、低噪晶体管、功率电阻及电容、放大器、功率管、MMIC、混频器、耦合器、功分器、振荡器、合成器、衰减器、滤波器、隔离器、环行器、移相器、调制解调器；光电子器件和组件：红外发射管、红外接收管、光电开关、光敏管、发光二极管和发光二极管组件、半导体激光二极管和激光器组件、光电探测器和光接收组件、光发射接收模块、光纤激光器和光放大器、光调制器、光开关、DWDM 用光发射和接收器件、用户接入系统光收发器件与模块、光纤连接器、光纤跳线/尾纤、光衰减器、光纤适配器、光隔离器、光耦合器、光环行器、光复用器/转换器；无线收发芯片和模组、蓝牙芯片和模组。

更多产品请看本公司产品专用销售网站：

商斯达中国传感器科技信息网：<http://www.sensor-ic.com/>

商斯达工控安防网：<http://www.pc-ps.net/>

商斯达电子元器件网：<http://www.sunstare.com/>

商斯达微波光电产品网：[HTTP://www.rfoe.net/](http://www.rfoe.net/)

商斯达消费电子产品网：<http://www.icasic.com/>

商斯达实业科技产品网：<http://www.sunstars.cn/> 微波元器件销售热线：

地址：深圳市福田区福华路福庆街鸿图大厦 1602 室

电话：0755-82884100 83397033 83396822 83398585

传真：0755-83376182 (0) 13823648918 MSN: SUNS8888@hotmail.com

邮编：518033 E-mail:szss20@163.com QQ: 195847376

深圳赛格展销部：深圳华强北路赛格电子市场 2583 号 电话：0755-83665529 25059422

技术支持：0755-83394033 13501568376

欢迎索取免费详细资料、设计指南和光盘；产品凡多，未能尽录，欢迎来电查询。

北京分公司：北京海淀区知春路 132 号中发电子大厦 3097 号

TEL: 010-81159046 82615020 13501189838 FAX: 010-62543996

上海分公司：上海市北京东路 668 号上海赛格电子市场 D125 号

TEL: 021-28311762 56703037 13701955389 FAX: 021-56703037

西安分公司：西安高新开发区 20 所(中国电子科技集团导航技术研究所)

西安劳动南路 88 号电子商城二楼 D23 号

TEL: 029-81022619 13072977981 FAX:029-88789382