



HB28J1000CCC/HB28J512CCC HB28J256CCC/HB28J128CCC

CompactFlash™

1 GByte/512 MByte/256 MByte/128 MByte

REJ03C0154-0100Z
(Previous ADE-203-1360(Z) Rev. 0.0)
Rev. 1.00
Dec. 03. 2003

Description

HB28J1000CCC, HB28J512CCC, HB28J256CCC, HB28J128CCC are CompactFlash™. This card complies with CompactFlash™ specification (CFA2.0), and is suitable for the usage of data storage memory medium for PC or any other electric equipment and digital still camera. This card is equipped with 0.13 μm CMOS 1Giga bit Flash memory. This card is suitable for ISA (Industry Standard Architecture) bus interface standard, and read/write unit is 1 sector (512 bytes) sequential access. By using this card it is possible to operate good performance for the system which have CompactFlash™ slots.

Note: CompactFlash™ is a trademark of SanDisk Corporation and is licensed royalty-free to the CFA which in turn will license it royalty-free to CFA members.

*CFA: CompactFlash™ Association.

Features

- CompactFlash™ specification standard
 - 50 pin two pieces connector and Type I (3.3 mm)
- 3.3 V / 5 V single power supply operation
- Card density is 1 Giga bytes maximum
 - This card is equipped with 0.13 μm CMOS 1 Giga bit Flash memory
- 3 variations of mode access
 - Memory card mode
 - I/O card mode
 - True IDE mode
 - PIO mode4

HB28J1000CCC/HB28J512CCC/HB28J256CCC/HB28J128CCC

- Internal self-diagnostic program operates at V_{cc} power on
- High reliability based on internal ECC (Error Correcting Code) function
- Auto sleep mode
- Data write is 100,000 cycles/block.*¹

Note: 1. One block consists of eight sectors (512 byte × 8).

Card Line Up*¹

| Type No. | Card density | Capacity*⁴ | Total sectors/ card*³ | Sectors/ track*² | Number of head | Number of cylinder |
|-----------------|---------------------|------------------------------|---|--|---------------------------|-------------------------------|
| HB28J1000CCC | 1 GB | 1,025,482,752 byte | 2,002,896 | 63 | 16 | 1987 |
| HB28J512CCC | 512 MB | 512,483,328 byte | 1,000,944 | 63 | 16 | 993 |
| HB28J256CCC | 256 MB | 256,204,800 byte | 500,400 | 48 | 15 | 695 |
| HB28J128CCC | 128 MB | 128,188,416 byte | 250,368 | 32 | 8 | 978 |

Notes: 1. These data are written in ID.

2. Total tracks = number of head × number of cylinder.

3. Total sectors/card = sectors/track × number of head × number of cylinder.

4. It is the logical address capacity including the area which is used for file system.

Card Pin Assignment

| Pin No. | Memory card mode | | I/O card mode | | True IDE mode | |
|---------|------------------|-----|---------------|-----|---------------|-----|
| | Signal name | I/O | Signal name | I/O | Signal name | I/O |
| 1 | GND | — | GND | — | GND | — |
| 2 | D3 | I/O | D3 | I/O | D3 | I/O |
| 3 | D4 | I/O | D4 | I/O | D4 | I/O |
| 4 | D5 | I/O | D5 | I/O | D5 | I/O |
| 5 | D6 | I/O | D6 | I/O | D6 | I/O |
| 6 | D7 | I/O | D7 | I/O | D7 | I/O |
| 7 | -CE1 | I | -CE1 | I | -CS0 | I |
| 8 | A10 | I | A10 | I | A10 | I |
| 9 | -OE | I | -OE | I | -ATASEL | I |
| 10 | A9 | I | A9 | I | A9 | I |
| 11 | A8 | I | A8 | I | A8 | I |
| 12 | A7 | I | A7 | I | A7 | I |
| 13 | VCC | — | VCC | — | VCC | — |
| 14 | A6 | I | A6 | I | A6 | I |
| 15 | A5 | I | A5 | I | A5 | I |
| 16 | A4 | I | A4 | I | A4 | I |
| 17 | A3 | I | A3 | I | A3 | I |
| 18 | A2 | I | A2 | I | A2 | I |
| 19 | A1 | I | A1 | I | A1 | I |
| 20 | A0 | I | A0 | I | A0 | I |
| 21 | D0 | I/O | D0 | I/O | D0 | I/O |
| 22 | D1 | I/O | D1 | I/O | D1 | I/O |
| 23 | D2 | I/O | D2 | I/O | D2 | I/O |
| 24 | WP | O | -IOIS16 | O | -IOIS16 | O |
| 25 | -CD2 | O | -CD2 | O | -CD2 | O |
| 26 | -CD1 | O | -CD1 | O | -CD1 | O |
| 27 | D11 | I/O | D11 | I/O | D11 | I/O |
| 28 | D12 | I/O | D12 | I/O | D12 | I/O |
| 29 | D13 | I/O | D13 | I/O | D13 | I/O |
| 30 | D14 | I/O | D14 | I/O | D14 | I/O |

HB28J1000CCC/HB28J512CCC/HB28J256CCC/HB28J128CCC

| Pin No. | Memory card mode | | I/O card mode | | True IDE mode | |
|---------|------------------|-----|---------------|-----|-------------------|-----|
| | Signal name | I/O | Signal name | I/O | Signal name | I/O |
| 31 | D15 | I/O | D15 | I/O | D15 | I/O |
| 32 | -CE2 | I | -CE2 | I | -CS1 | I |
| 33 | -VS1 | O | -VS1 | O | -VS1 | O |
| 34 | -IORD | I | -IORD | I | -IORD | I |
| 35 | -IOWR | I | -IOWR | I | -IOWR | I |
| 36 | -WE | I | -WE | I | -WE | I |
| 37 | RDY/-BSY | O | -IREQ | O | INTRQ | O |
| 38 | VCC | — | VCC | — | VCC | — |
| 39 | -CSEL | I | -CSEL | I | -CSEL | I |
| 40 | -VS2 | O | -VS2 | O | -VS2 | O |
| 41 | RESET | I | RESET | I | -RESET | I |
| 42 | -WAIT | O | -WAIT | O | IORDY | O |
| 43 | -INPACK | O | -INPACK | O | RFU* ¹ | O |
| 44 | -REG | I | -REG | I | RFU* ¹ | I |
| 45 | BVD2 | I/O | -SPKR | I/O | -DASP | I/O |
| 46 | BVD1 | I/O | -STSCHG | I/O | -PDIAG | I/O |
| 47 | D8 | I/O | D8 | I/O | D8 | I/O |
| 48 | D9 | I/O | D9 | I/O | D9 | I/O |
| 49 | D10 | I/O | D10 | I/O | D10 | I/O |
| 50 | GND | — | GND | — | GND | — |

Note: 1. RFU is Reserved for Future Use.

Card Pin Explanation

| Signal name | Direction | Pin No. | Description |
|--|-----------|---|--|
| A10 to A0 (PC Card Memory mode) | I | 8, 10, 11, 12, 14, 15, 16, 17, 18, 19, 20 | Address bus is A10 to A0. A10 is MSB and A0 is LSB. |
| A10 to A0 (PC Card I/O mode) | | | |
| A2 to A0 (True IDE mode) | | 18, 19, 20 | Address bus is A10 to A0. Only A2 to A0 are used, A10 to A3 should be grounded by the host. |
| BVD1 (PC Card Memory mode) | I/O | 46 | BVD1 outputs the battery voltage status in the card. This output line is constantly driven to a high state since a battery is not required for this product. |
| -STSCHG (PC Card I/O mode) | | | -STSCHG is used for changing the status of Configuration and status register in attribute area. |
| -PDIAG (True IDE mode) | | | -PDIAG is the Pass Diagnostic signal in Master/Slave handshake protocol. |
| BVD2 (PC Card Memory mode) | I/O | 45 | BVD2 outputs the battery voltage status in the card. This output line is constantly driven to a high state since a battery is not required for this product. |
| -SPKR (PC Card I/O mode) | | | -SPKR outputs speaker signals. This output line is constantly driven to a high state since this product does not support the audio function. |
| -DASP (True IDE mode) | | | -DASP is the Disk Active/Slave Present signal in the Master/Slave handshake protocol. |
| -CD1, -CD2 (PC Card Memory mode) | O | 26, 25 | -CD1 and -CD2 are the card detection signals. -CD1 and -CD2 are connected to ground in this card, so host can detect that the card is inserted or not. |
| -CD1, -CD2 (PC Card I/O mode) | | | |
| -CD1, -CD2 (True IDE mode) | | | |
| -CE1, -CE2 (PC Card Memory mode) Card Enable | I | 7, 32 | -CE1 and -CE2 are low active card select signals. Byte/Word/Odd byte modes are defined by combination of -CE1, -CE2 and A0. |
| -CE1, -CE2 (PC Card I/O mode) Card Enable | | | |
| -CS0, -CS1 (True IDE mode) | | | -CS1 is used for select the Alternate Status Register and the Device Control Register -CS0 is the chip select for the other task file registers. |

HB28J1000CCC/HB28J512CCC/HB28J256CCC/HB28J128CCC

| Signal name | Direction | Pin No. | Description |
|--|-----------|---|---|
| -CSEL (PC Card Memory mode) | I | 39 | This signal is not used. |
| -CSEL (PC Card I/O mode) | | | |
| -CSEL (True IDE mode) | | | This signal is used to configure this device as a Master or a Slave when configured in the True IDE mode. When this pin is grounded, this device is configured as a Master. When the pin is open, this device is configured as a Slave. |
| D15 to D0 (PC Card Memory mode) | I/O | 31, 30, 29, 28, 27, 49, 48, 47, 6, 5, 4, 3, 2, 23, 22, 21 | Data bus is D15 to D0. D0 is the LSB of the even byte of the word. D8 is the LSB of the odd byte of the word. |
| D15 to D0 (PC Card I/O mode) | | | |
| D15 to D0 (True IDE mode) | | | |
| GND (PC Card Memory mode) | — | 1, 50 | Ground |
| GND (PC Card I/O mode) | | | |
| GND (True IDE mode) | | | |
| -INPACK (PC Card Memory mode) | O | 43 | This signal is not used and should not be connected at the host. |
| -INPACK (PC Card I/O mode) Input Acknowledge | | | This signal is asserted low by this card when the card is selected and responding to an I/O read cycle at the address that is on the address bus during -CE and -IORD are low. This signal is used for the input data buffer control. |
| RFU (True IDE mode) | | | This signal is not used and should not be connected at the host. |
| -IORD (PC Card Memory mode) | I | 34 | This signal is not used. |
| -IORD (PC Card I/O mode) | | | -IORD is used for control of read data in I/O task file area. This card does not respond to -IORD until I/O card interface setting up. |
| -IORD (True IDE mode) | | | -IORD is used for control of read data in I/O task file area. This card does not respond to -IORD until True IDE interface setting up. |

HB28J1000CCC/HB28J512CCC/HB28J256CCC/HB28J128CCC

| Signal name | Direction | Pin No. | Description |
|--|-----------|---------|--|
| -IOWR (PC Card Memory mode) | I | 35 | This signal is not used. |
| -IOWR (PC Card I/O mode) | | | -IOWR is used for control of data write in I/O task file area. This card does not respond to -IOWR until I/O card interface setting up. |
| -IOWR (True IDE mode) | | | -IOWR is used for control of data write in I/O task file area. This card does not respond to -IOWR until True IDE interface setting up. |
| -OE (PC Card Memory mode) | I | 9 | -OE is used for the control of reading register's data in attribute area or task file area. |
| -OE (PC Card I/O mode) | | | -OE is used for the control of reading register's data in attribute area. |
| -ATASEL (True IDE mode) | | | To enable True IDE mode this input should be grounded by the host. |
| RDY/-BSY (PC Card Memory mode) | O | 37 | The signal is RDY/-BSY pin. RDY/-BSY pin turns low level during the card internal initialization operation at VCC applied or reset applied, so next access to the card should be after the signal turned high level. |
| -IREQ (PC Card I/O mode) | | | This signal is active low -IREQ pin. The signal of low level indicates that the card is requesting software service to host, and high level indicates that the card is not requesting. |
| INTRQ (True IDE mode) | | | This signal is the active high Interrupt Request to the host. |
| -REG (PC Card Memory mode) Attribute memory select | I | 44 | -REG is used during memory cycles to distinguish between task file and attribute memory accesses. High for task file, Low for attribute memory is accessed. |
| -REG (PC Card I/O mode) | | | -REG is constantly low when task file or attribute memory is accessed. |
| RFU (True IDE mode) | | | This input signal is not used and should be connected to VCC by the host. |

HB28J1000CCC/HB28J512CCC/HB28J256CCC/HB28J128CCC

| Signal name | Direction | Pin No. | Description |
|-------------------------------------|-----------|---------|--|
| RESET (PC Card Memory mode) | I | 41 | This signal is active high RESET pin. If this signal is asserted high, the card internal initialization begins to operate. During the card internal initialization RDY/-BSY is low. After the card internal initialization RDY/-BSY is high. |
| RESET (PC Card I/O mode) | | | This signal is active high RESET pin. If this signal is asserted high, the card internal initialization begins to operate. In this mode, RDY/-BSY signal cannot be used, so using Status Register the Ready/Busy status can be confirmed. |
| -RESET (True IDE mode) | | | This signal is active low -RESET pin. If this signal is asserted low, all the registers in this card are reset. In this mode, RDY/-BSY signal cannot be used, so using status register the Ready/Busy status can be confirmed. |
| VCC (PC Card Memory mode) | — | 13, 38 | +5 V, +3.3 V power. |
| VCC (PC Card I/O mode) | | | |
| VCC (True IDE mode) | | | |
| -VS1, -VS2 (PC Card Memory mode) | O | 33, 40 | These signals are intended to notify VCC requirement to host. -VS1 is held grounded and -VS2 is nonconnected in this card. |
| -VS1, -VS2 (PC Card I/O mode) | | | |
| -VS1, -VS2 (True IDE mode) | | | |
| -WAIT (PC Card Memory mode) | O | 42 | This signal is active low -WAIT pin. In this card this signal is constantly high level. |
| -WAIT (PC Card I/O mode) | | | |
| IORDY (True IDE mode) | | | This output signal may be used as IORDY. In this card this signal is constantly high impedance. |
| -WE (PC Card Memory mode) | I | 36 | -WE is used for the control of writing register's data in attribute memory area or task file area. |
| -WE (PC Card I/O mode) | | | -WE is used for the control of writing register's data in attribute memory area. |
| -WE (True IDE mode) | | | This input signal is not used and should be connected to VCC by the host. |

HB28J1000CCC/HB28J512CCC/HB28J256CCC/HB28J128CCC

| Signal name | Direction | Pin No. | Description |
|--|------------------|----------------|---|
| WP (PC Card Memory mode) Write Protect | O | 24 | WP is held low because this card does not have write protect switch. |
| -IOIS16 (PC Card I/O mode) | | | -IOIS16 is asserted when task file registers are accessed in 16-bit mode. |
| -IOIS16 (True IDE mode) | | | This output signal is asserted low when this device is expecting a word data transfer cycle. Initial mode is 16-bit. If the user issues a Set Feature Command to put the device in Byte access mode, the card permits 8-bit accesses. |

Card Block Diagram

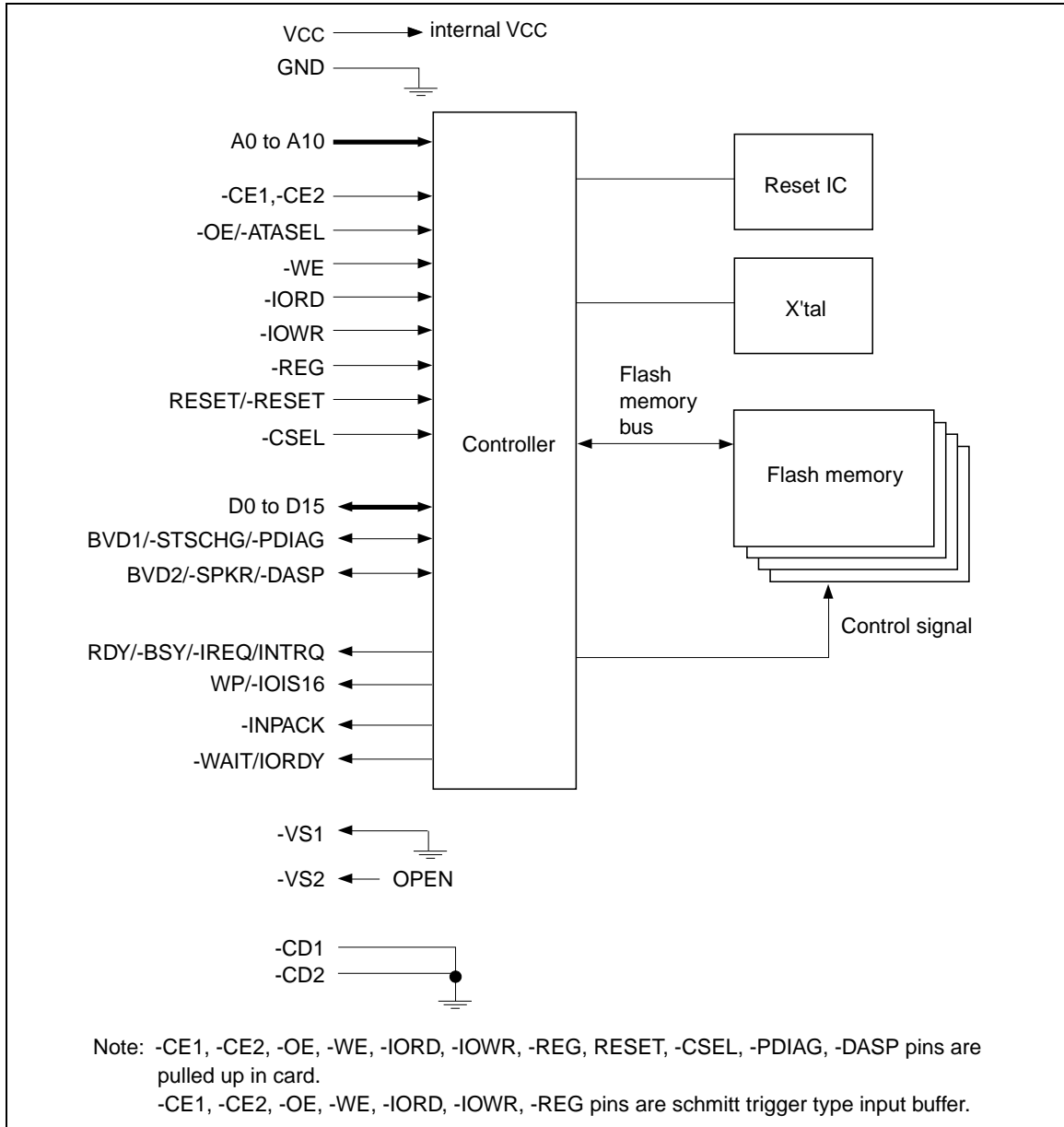

Card Function Explanation

Register construction

- Attribute region
 - Configuration register
 - Configuration Option register
 - Configuration and Status register
 - Pin Replacement register
 - Socket and Copy register
 - CIS (Card Information Structure)
- Task File region
 - Data register
 - Error register
 - Feature register
 - Sector Count register
 - Sector Number register
 - Cylinder Low register
 - Cylinder High register
 - Drive Head register
 - Status register
 - Alternate Status register
 - Command register
 - Device Control register
 - Drive Address register

Host access specifications

1. Attribute access specifications

When CIS-ROM region or Configuration register region is accessed, read and write operations are executed under the condition of -REG = "L" as follows. That region can be accessed by Byte/Word/Odd-byte modes which are defined by PC card standard specifications.

Attribute Read Access Mode

| Mode | -REG | -CE2 | -CE1 | A0 | -OE | -WE | D8 to D15 | D0 to D7 |
|-------------------------|------|------|------|----|-----|-----|-----------|-----------|
| Standby mode | × | H | H | × | × | × | High-Z | High-Z |
| Byte access (8-bit) | L | H | L | L | L | H | High-Z | even byte |
| | L | H | L | H | L | H | High-Z | invalid |
| Word access (16-bit) | L | L | L | × | L | H | invalid | even byte |
| Odd byte access (8-bit) | L | L | H | × | L | H | invalid | High-Z |

Note: ×: L or H

Attribute Write Access Mode

| Mode | -REG | -CE2 | -CE1 | A0 | -OE | -WE | D8 to D15 | D0 to D7 |
|-------------------------|------|------|------|----|-----|-----|------------|------------|
| Standby mode | × | H | H | × | × | × | Don't care | Don't care |
| Byte access (8-bit) | L | H | L | L | H | L | Don't care | even byte |
| | L | H | L | H | H | L | Don't care | Don't care |
| Word access (16-bit) | L | L | L | × | H | L | Don't care | even byte |
| Odd byte access (8-bit) | L | L | H | × | H | L | Don't care | Don't care |

Note: ×: L or H

Attribute Access Timing Example

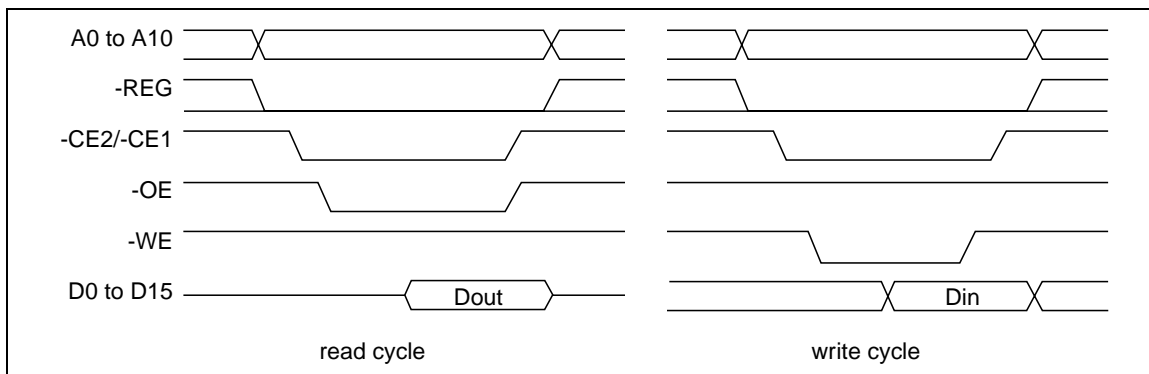

2. Task File register access specifications

There are two cases of Task File register mapping, one is mapped I/O address area, and the other is mapped Memory address area. Each case of Task File register read and write operations are executed under the condition as follows. That area can be accessed by Byte/Word/Odd Byte modes which are defined by PC card standard specifications.

(1) I/O address map

Task File Register Read Access Mode (1)

| Mode | -REG | -CE2 | -CE1 | A0 | -IORD | -IOWR | -OE | -WE | D8 to D15 | D0 to D7 |
|-------------------------|------|------|------|----|-------|-------|-----|-----|-----------|-----------|
| Standby mode | × | H | H | × | × | × | × | × | High-Z | High-Z |
| Byte access (8-bit) | L | H | L | L | L | H | H | H | High-Z | even byte |
| | L | H | L | H | L | H | H | H | High-Z | odd byte |
| Word access (16-bit) | L | L | L | × | L | H | H | H | odd byte | even byte |
| Odd byte access (8-bit) | L | L | H | × | L | H | H | H | odd byte | High-Z |

Note: ×: L or H

Task File Register Write Access Mode (1)

| Mode | -REG | -CE2 | -CE1 | A0 | -IORD | -IOWR | -OE | -WE | D8 to D15 | D0 to D7 |
|-------------------------|------|------|------|----|-------|-------|-----|-----|------------|------------|
| Standby mode | × | H | H | × | × | × | × | × | Don't care | Don't care |
| Byte access (8-bit) | L | H | L | L | H | L | H | H | Don't care | even byte |
| | L | H | L | H | H | L | H | H | Don't care | odd byte |
| Word access (16-bit) | L | L | L | × | H | L | H | H | odd byte | even byte |
| Odd byte access (8-bit) | L | L | H | × | H | L | H | H | odd byte | Don't care |

Note: ×: L or H

Task File Register Access Timing Example (1)

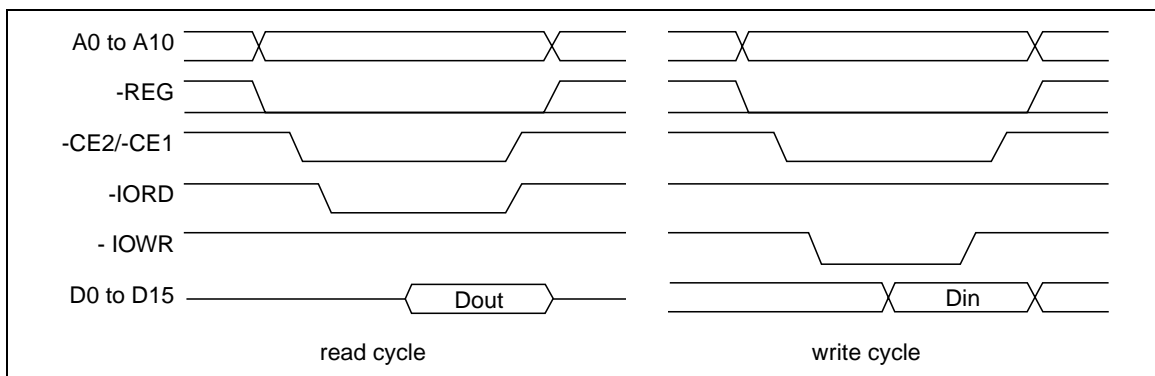

(2) Memory address map

Task File Register Read Access Mode (2)

| Mode | -REG | -CE2 | -CE1 | A0 | -OE | -WE | -IORD | -IOWR | D8 to D15 | D0 to D7 |
|-------------------------|------|------|------|----|-----|-----|-------|-------|-----------|-----------|
| Standby mode | × | H | H | × | × | × | × | × | High-Z | High-Z |
| Byte access (8-bit) | H | H | L | L | L | H | H | H | High-Z | even byte |
| | H | H | L | H | L | H | H | H | High-Z | odd byte |
| Word access (16-bit) | H | L | L | × | L | H | H | H | odd byte | even byte |
| Odd byte access (8-bit) | H | L | H | × | L | H | H | H | odd byte | High-Z |

Note: ×: L or H

Task File Register Write Access Mode (2)

| Mode | -REG | -CE2 | -CE1 | A0 | -OE | -WE | -IORD | -IOWR | D8 to D15 | D0 to D7 |
|-------------------------|------|------|------|----|-----|-----|-------|-------|------------|------------|
| Standby mode | × | H | H | × | × | × | × | × | Don't care | Don't care |
| Byte access (8-bit) | H | H | L | L | H | L | H | H | Don't care | even byte |
| | H | H | L | H | H | L | H | H | Don't care | odd byte |
| Word access (16-bit) | H | L | L | × | H | L | H | H | odd byte | even byte |
| Odd byte access (8-bit) | H | L | H | × | H | L | H | H | odd byte | Don't care |

Note: ×: L or H

Task File Register Access Timing Example (2)

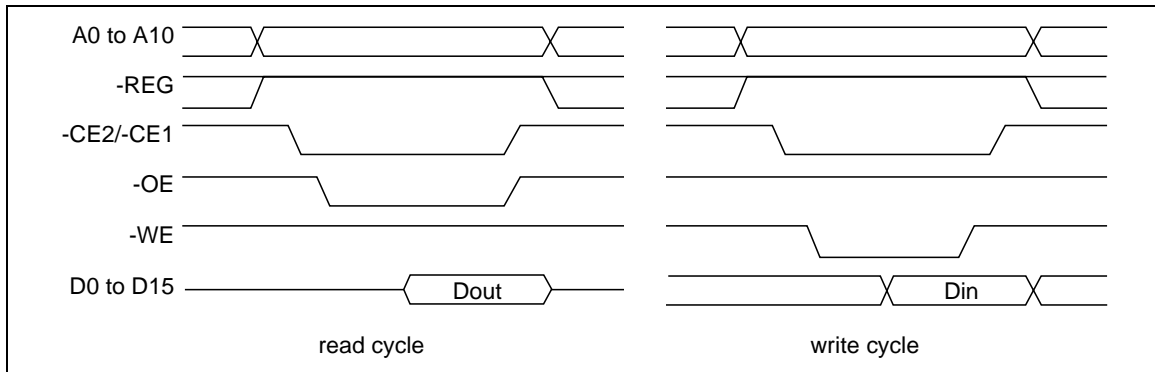

3. True IDE Mode

The card can be configured in a True IDE mode of operation. This card is configured in this mode only when the -OE input signal is asserted GND by the host. In this True IDE mode Attribute Registers are not accessible from the host. Only I/O operation to the task file and data register is allowed. If this card is configured during power on sequence, data register is accessed in word (16-bit). The card permits 8-bit accesses if the user issues a Set Feature Command to put the device in 8-bit mode.

True IDE Mode Read I/O Function

| Mode | -CS1 | -CS0 | A0 to A2 | -IOR | -IOWR | D8 to D15 | D0 to D7 |
|-------------------------|------|------|----------|------|-------|-----------|------------|
| Invalid mode | L | L | × | × | × | High-Z | High-Z |
| Standby mode | H | H | × | × | × | High-Z | High-Z |
| Data register access | H | L | 0 | L | H | odd byte | even byte |
| Alternate status access | L | H | 6H | L | H | High-Z | status out |
| Other task file access | H | L | 1-7H | L | H | High-Z | data |

Note: ×: L or H

True IDE Mode Write I/O Function

| Mode | -CS1 | -CS0 | A0 to A2 | -IOR | -IOWR | D8 to D15 | D0 to D7 |
|-------------------------|------|------|----------|------|-------|------------|------------|
| Invalid mode | L | L | × | × | × | don't care | don't care |
| Standby mode | H | H | × | × | × | don't care | don't care |
| Data register access | H | L | 0 | H | L | odd byte | even byte |
| Control register access | L | H | 6H | H | L | don't care | control in |
| Other task file access | H | L | 1-7H | H | L | don't care | data |

Note: ×: L or H

True IDE Mode I/O Access Timing Example

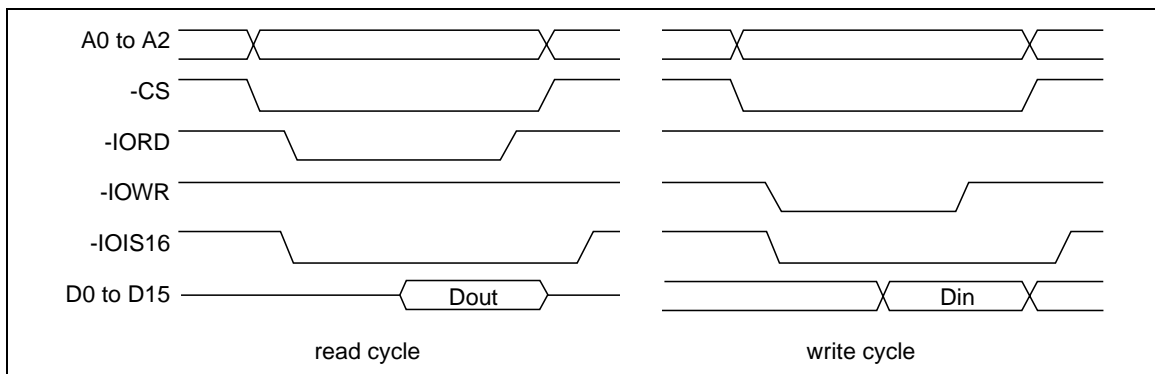

Configuration register specifications

This card supports four Configuration registers for the purpose of the configuration and observation of this card. These registers can be used in memory card mode and I/O card mode. In True IDE mode, these registers cannot be used.

1. Configuration Option register (Address 200H)

This register is used for the configuration of the card configuration status and for the issuing soft reset to the card.

| bit7 | bit6 | bit5 | bit4 | bit3 | bit2 | bit1 | bit0 |
|--------|---------|-------|------|------|------|------|------|
| SRESET | LevIREQ | INDEX | | | | | |

Note: initial value: 00H

| Name | R/W | Function |
|---------------------|-----|--|
| SRESET (HOST->) | R/W | Setting this bit to "1", places the card in the reset state (Card Hard Reset). This operation is equal to Hard Reset, except this bit is not cleared. Then this bit set to "0", places the card in the reset state of Hard Reset (This bit is set to "0" by Hard Reset) . Card configuration status is reset and the card internal initialized operation starts when Card Hard Reset is executed, so next access to the card should be the same sequence as the power on sequence. |
| LevIREQ (HOST->) | R/W | This bit sets to "0" when pulse mode interrupt is selected, and "1" when level mode interrupt is selected. |
| INDEX (HOST->) | R/W | This bit is used for select operation mode of the card as follows. When Power on, Card Hard Reset and Soft Reset, this data is "000000" for the purpose of Memory card interface recognition. |

INDEX bit assignment

| INDEX bit | | | | | | Card mode | Task File register address | Mapping mode |
|-----------|---|---|---|---|---|-------------|----------------------------|-----------------------|
| 5 | 4 | 3 | 2 | 1 | 0 | | | |
| 0 | 0 | 0 | 0 | 0 | 0 | Memory card | 0H to FH, 400H to 7FFH | memory mapped |
| 0 | 0 | 0 | 0 | 0 | 1 | I/O card | xx0H to xxFH | contiguous I/O mapped |
| 0 | 0 | 0 | 0 | 1 | 0 | I/O card | 1F0H to 1F7H, 3F6H to 3F7H | primary I/O mapped |
| 0 | 0 | 0 | 0 | 1 | 1 | I/O card | 170H to 177H, 376H to 377H | secondary I/O mapped |

HB28J1000CCC/HB28J512CCC/HB28J256CCC/HB28J128CCC

2. Configuration and Status register (Address 202H)

This register is used for observing the card state.

| bit7 | bit6 | bit5 | bit4 | bit3 | bit2 | bit1 | bit0 |
|-------|--------|-------|------|------|------|------|------|
| CHGED | SIGCHG | IOIS8 | 0 | 0 | PWD | INTR | 0 |

Note: initial value: 00H

| Name | R/W | Function |
|--------------------|-----|---|
| CHGED (CARD->) | R | This bit indicates that CRDY/-BSY bit on Pin Replacement register is set to "1". When CHGED bit is set to "1", -STSCHG pin is held "L" at the condition of SIGCHG bit set to "1" and the card configured for the I/O interface. |
| SIGCHG (HOST->) | R/W | This bit is set or reset by the host for enabling and disabling the status-change signal (-STSCHG pin). When the card is configured I/O card interface and this bit is set to "1", -STSCHG pin is controlled by CHGED bit. If this bit is set to "0", -STSCHG pin is kept "H". |
| IOIS8 (HOST->) | R/W | The host sets this field to "1" when it can provide I/O cycles only with on 8-bit data bus (D7 to D0). |
| PWD (HOST->) | R/W | When this bit is set to "1", the card enters sleep state (Power Down mode). When this bit is reset to "0", the card transfers to idle state (active mode). RRDY/-BSY bit on Pin Replacement Register becomes BUSY when this bit is changed. RRDY/-BSY will not become Ready until the power state requested has been entered. This card automatically powers down when it is idle, and powers back up when it receives a command. |
| INTR (CARD->) | R | This bit indicates the internal state of the interrupt request. This bit state is available whether I/O card interface has been configured or not. This signal remains true until the condition which caused the interrupt request has been serviced. If interrupts are disabled by the -IEN bit in the Device Control Register, this bit is a zero. |

HB28J1000CCC/HB28J512CCC/HB28J256CCC/HB28J128CCC

3. Pin Replacement register (Address 204H)

This register is used for providing the signal state of -IREQ signal when the card configured I/O card interface.

| bit7 | bit6 | bit5 | bit4 | bit3 | bit2 | bit1 | bit0 |
|------|------|-----------|------|------|------|-----------|------|
| 0 | 0 | CRDY/-BSY | 0 | 1 | 1 | RRDY/-BSY | 0 |

Note: initial value: 0CH

| Name | R/W | Function |
|--------------------|-----|--|
| CRDY/-BSY (HOST->) | R/W | This bit is set to "1" when the RRDY/-BSY bit changes state. This bit may also be written by the host. |
| RRDY/-BSY (HOST->) | R/W | When read, this bit indicates +READY pin states. When written, this bit is used for CRDY/-BSY bit masking. |

4. Socket and Copy register (Address 206H)

This register is used for identification of the card from the other cards. Host can read and write this register. This register should be set by host before this card's Configuration Option register set.

| bit7 | bit6 | bit5 | bit4 | bit3 | bit2 | bit1 | bit0 |
|------|------|------|------|------|------|------|------|
| 0 | 0 | 0 | DRV# | 0 | 0 | 0 | 0 |

Note: initial value: 00H

| Name | R/W | Function |
|---------------|-----|---|
| DRV# (HOST->) | R/W | These fields are used for the configuration of the plural cards. When host configures the plural cards, written the card's copy number in this field. In this way, host can perform the card's master/slave organization. |

CIS informations

CIS informations are defined as follows. By reading attribute address from “0000 H”, card CIS informations can be confirmed.

| Address | Data | 7 | 6 | 5 | 4 | 3 | 2 | 1 | 0 | Description of contents | CIS function |
|---------|------|---|----------------|-----------------|---|-----------------------|---|---|-------------|---|-------------------------------------|
| 000H | 01H | CISTPL_DEVICE | | | | | | | | Device info tuple | Tuple code |
| 002H | 04H | TPL_LINK | | | | | | | | Link length is 4 byte | Link to next tuple |
| 004H | DFH | Device type | W | Device speed | Device type = DH: I/O device WPS = 1: No WP Device speed = 7: ext speed | | | | | | |
| | | | P | | | | | | | | |
| | | | S | | | | | | | | |
| 006H | 4AH | EXT | Speed mantissa | Speed exponent | 400 ns if no wait | | | | | Extended speed | |
| 008H | 01H | 1x | 2k units | | 2k byte of address space | | | | Device size | | |
| 00AH | FFH | List end marker | | | | | | | | End of device | END marker |
| 00CH | 1CH | CISTPL_DEVICE_OC | | | | | | | | Other conditions device info tuple | Tuple code |
| 00EH | 04H | TPL_LINK | | | | | | | | Link length is 4 bytes | Link to next tuple |
| 010H | 02H | EXT | Reserved | V _{cc} | MWAIT | 3 V, wait is not used | | | | Other conditions info field | |
| 012H | D9H | Device type | W | Device speed | Device type = DH: I/O device WPS = 1: No WP Device speed = 1: 250 ns | | | | | | |
| | | | P | | | | | | | | |
| | | | S | | | | | | | | |
| 014H | 01H | 1x | 2k units | | 2k byte of address space | | | | Device size | | |
| 016H | FFH | List end marker | | | | | | | | End of device | END marker |
| 018H | 18H | CISTPL_JEDEC_C | | | | | | | | JEDEC ID common memory | Tuple code |
| 01AH | 02H | TPL_LINK | | | | | | | | Link length is 2 bytes | Link to next tuple |
| 01CH | DFH | PCMCIA's manufacturer's JEDEC ID code | | | | | | | | Manufacturer's ID code | JEDEC ID of PC Card ATA |
| 01EH | 01H | PCMCIA JEDEC device code | | | | | | | | 2 nd byte of JEDEC ID | |
| 020H | 20H | CISTPL_MANFID | | | | | | | | Manufacturer's ID code | Tuple code |
| 022H | 04H | TPL_LINK | | | | | | | | Link length is 4 bytes | Link to next tuple |
| 024H | 07H | Low byte of PCMCIA manufacturer's code | | | | | | | | HITACHI JEDEC manufacturer's ID | Low byte of manufacturer's ID code |
| 026H | 00H | High byte of PCMCIA manufacturer's code | | | | | | | | Code of 0 because other byte is JEDEC 1 byte manufacture's ID | High byte of manufacturer's ID code |
| 028H | 00H | Low byte of product code | | | | | | | | HITACHI code for PC CARD ATA | Low byte of product code |
| 02AH | 00H | High byte of product code | | | | | | | | | High byte of product code |

HB28J1000CCC/HB28J512CCC/HB28J256CCC/HB28J128CCC

| Address | Data | 7 | 6 | 5 | 4 | 3 | 2 | 1 | 0 | Description of contents | CIS function |
|---------|------|-----------------------|---|---|---|-----|---|---|---|---|----------------------------|
| 02CH | 15H | CISTPL_VERS_1 | | | | | | | | Level 1 version/product info | Tuple code |
| 02EH | 15H | TPL_LINK | | | | | | | | Link length is 15h bytes | Link to next tuple |
| 030H | 04H | TPPLV1_MAJOR | | | | | | | | PCMCIA2.0/JEIDA4.1 | Major version |
| 032H | 01H | TPPLV1_MINOR | | | | | | | | PCMCIA2.0/JEIDA4.1 | Minor version |
| 034H | 48H | | | | | | | | | ' H ' | Info string 1 |
| 036H | 49H | | | | | | | | | ' I ' | |
| 038H | 54H | | | | | | | | | ' T ' | |
| 03AH | 41H | | | | | | | | | ' A ' | |
| 03CH | 43H | | | | | | | | | ' C ' | |
| 03EH | 48H | | | | | | | | | ' H ' | |
| 040H | 49H | | | | | | | | | ' I ' | |
| 042H | 00H | | | | | | | | | Null terminator | |
| 044H | 46H | | | | | | | | | ' F ' | Info string 2 |
| 046H | 4CH | | | | | | | | | ' L ' | |
| 048H | 41H | | | | | | | | | ' A ' | |
| 04AH | 53H | | | | | | | | | ' S ' | |
| 04CH | 48H | | | | | | | | | ' H ' | |
| 04EH | 00H | | | | | | | | | Null terminator | |
| 050H | 35H | | | | | | | | | ' 5 ' | |
| 052H | 2EH | | | | | | | | | ' . ' | |
| 054H | 30H | | | | | | | | | ' 0 ' | |
| 056H | 00H | | | | | | | | | Null terminator | |
| 058H | FFH | List end marker | | | | | | | | End of device | END marker |
| 05AH | 21H | CISTPL_FUNCID | | | | | | | | Function ID tuple | Tuple code |
| 05CH | 02H | TPL_LINK | | | | | | | | Link length is 2 bytes | Link to next tuple |
| 05EH | 04H | TPLFID_FUNCTION = 04H | | | | | | | | Disk function, may be silicon, PC card function code may be removable | |
| 060H | 01H | Reserved | | | | R P | | | | R = 0: No BIOS ROM P = 1: Configure card at power on | System initialization byte |

HB28J1000CCC/HB28J512CCC/HB28J256CCC/HB28J128CCC

| Address | Data | 7 | 6 | 5 | 4 | 3 | 2 | 1 | 0 | Description of contents | CIS function |
|---------|------|------------------------------------|-----|-----|---|----|----|----|----|--|---|
| 062H | 22H | CISTPL_FUNCE | | | | | | | | Function extension tuple | Tuple code |
| 064H | 02H | TPL_LINK | | | | | | | | Link length is 2 bytes | Link to next tuple |
| 066H | 01H | Disk function extension tuple type | | | | | | | | Disk interface type | Extension tuple type for disk |
| 068H | 01H | Disk interface type | | | | | | | | PC card ATA interface | Interface type |
| 06AH | 22H | CISTPL_FUNCE | | | | | | | | Function extension tuple | Tuple code |
| 06CH | 03H | TPL_LINK | | | | | | | | Link length is 3 bytes | Link to next tuple |
| 06EH | 02H | Disk function extension tuple type | | | | | | | | Single drive | Extension tuple type for disk |
| 070H | 0CH | Reserved | D | U | S | V | | | | No V_{pp} , silicon, single drive V = 0: No V_{pp} required S = 1: Silicon U = 1: Unique serial # D = 0: Single drive on card | Basic ATA option parameters byte 1 |
| 072H | 0FH | R | I | E | N | P3 | P2 | P1 | P0 | P0: Sleep mode supported P1: Standby mode supported P2: Idle mode supported P3: Drive auto power control N: Some config excludes 3X7 E: Index bit is emulated I: Twin IOIS16# data reg only R: Reserved | Basic ATA option parameters byte 2 |
| 074H | 1AH | CISTPL_CONFIG | | | | | | | | Configuration tuple | Tuple code |
| 076H | 05H | TPL_LINK | | | | | | | | Link length is 5 bytes | Link to next tuple |
| 078H | 01H | RFS | RMS | RAS | | | | | | RFS: Reserved RMS: TPCC_RMSK size - 1 = 0 RAS: TPCC_RADR size - 1 = 1 1 byte register mask 2 byte config base address | Size of fields byte TPCC_SZ |
| 07AH | 03H | TPCC_LAST | | | | | | | | Entry with config index of 03H is final entry in table | Last entry of config registers |
| 07CH | 00H | TPCC_RADR (LSB) | | | | | | | | Configuration registers are located at 200H in REG space | Location of config registers |
| 07EH | 02H | TPCC_RADR (MSB) | | | | | | | | | |
| 080H | 0FH | Reserved | S | P | C | I | | | | I: Configuration index C: Configuration and status P: Pin replacement S: Socket and copy | Configuration registers present mask TPCC_RMSK |

HB28J1000CCC/HB28J512CCC/HB28J256CCC/HB28J128CCC

| Address | Data | 7 | 6 | 5 | 4 | 3 | 2 | 1 | 0 | Description of contents | CIS function | |
|---------|------|---------------------------------|----------|---------------------|----|----------------|----------|----|----|--|---|---|
| 082H | 1BH | CISTPL_CFTABLE_ENTRY | | | | | | | | Configuration table entry tuple | Tuple code | |
| 084H | 08H | TPL_LINK | | | | | | | | Link length is 8 bytes | Link to next tuple | |
| 086H | C0H | I | D | Configuration index | | | | | | | Memory mapped I/O configuration I = 1: Interface byte follows D = 1: Default entry Configuration index = 0 | Configuration table index byte TPCE_INDX |
| 088H | 40H | W | R | P | B | Interface type | | | | W = 0: Wait not used R = 1: Ready active P = 0: WP not used B = 0: BVD1 and BVD2 not used IF type = 0: Memory interface | Interface description field TPCE_IF | |
| 08AH | A1H | M | MS | IR | IO | T | P | | | | M = 1: Misc info present MS = 01: Memory space info single 2-byte length IR = 0: No interrupt info present IO = 0: No I/O port info present T = 0: No timing info present P = 1: V _{cc} only info | Feature selection byte TPCE_FS |
| 08CH | 01H | R | DI | PI | AI | SI | HV | LV | NV | Nominal voltage only follows R: Reserved DI: Power down current info PI: Peak current info AI: Average current info SI: Static current info HV: Max voltage info LV: Min voltage info NV: Nominal voltage info | Power parameters for V _{cc} | |
| 08EH | 55H | X | Mantissa | | | | Exponent | | | Nominal voltage = 5 V | V _{cc} nominal value | |
| 090H | 08H | Length in 256 bytes pages (LSB) | | | | | | | | Length of memory space is 2 kB | Memory space description structures (TPCE_MS) | |
| 092H | 00H | Length in 256 bytes pages (MSB) | | | | | | | | | | |
| 094H | 20H | X | R | P | RO | A | T | | | | X = 0: No more misc fields R: Reserved P = 1: Power down supported RO = 0: Not read only mode A = 0: Audio not supported T = 0: Single drive | Miscellaneous features field TPCE_MI |

HB28J1000CCC/HB28J512CCC/HB28J256CCC/HB28J128CCC

| Address | Data | 7 | 6 | 5 | 4 | 3 | 2 | 1 | 0 | Description of contents | CIS function | |
|---------|------|----------------------|-----------|----|---------------------|----|----------|----|----|--|--|--|
| 096H | 1BH | CISTPL_CFTABLE_ENTRY | | | | | | | | Configuration table entry tuple | Tuple code | |
| 098H | 06H | TPL_LINK | | | | | | | | Link length is 6 bytes | Link to next tuple | |
| 09AH | 00H | I | | D | Configuration index | | | | | | Memory mapped I/O configuration I = 0: No Interface byte D = 0: No Default entry Configuration index = 0 | Configuration table index byte TPCE_INDXX |
| 09CH | 01H | M | MS | IR | IO | T | P | | | | M = 0: No Misc info MS = 00: No Memory space info IR = 0: No interrupt info present IO = 0: No I/O port info present T = 0: No timing info present P = 1: V _{cc} only info | Feature selection byte TPCE_FS |
| 09EH | 21H | R | DI | PI | AI | SI | HV | LV | NV | Nominal voltage only follows R: Reserved DI: Power down current info PI: Peak current info AI: Average current info SI: Static current info HV: Max voltage info LV: Min voltage info NV: Nominal voltage info | Power parameters for V _{cc} | |
| 0A0H | B5H | X | Mantissa | | | | Exponent | | | Nominal voltage = 3.0 V | V _{cc} nominal value | |
| 0A2H | 1EH | X | Extension | | | | | | | | +0.3 V | Extension byte |
| 0A4H | 4DH | X | Mantissa | | | | Exponent | | | Max average current over 10 msec is 45 mA | Max. average current | |

HB28J1000CCC/HB28J512CCC/HB28J256CCC/HB28J128CCC

| Address | Data | 7 | 6 | 5 | 4 | 3 | 2 | 1 | 0 | Description of contents | CIS function | |
|---------|------|----------------------|----------|---------------------|-------------|----------------|----------|----|----|---|---|---|
| 0A6H | 1BH | CISTPL_CFTABLE_ENTRY | | | | | | | | Configuration table entry tuple | Tuple code | |
| 0A8H | 0AH | TPL_LINK | | | | | | | | Link length is 10 bytes | Link to next tuple | |
| 0AAH | C1H | I | D | Configuration INDEX | | | | | | | Contiguous I/O mapped ATA registers configuration I = 1: Interface byte follows D = 1: Default entry Configuration index = 1 | Configuration table index byte TPCE_INDXX |
| 0ACH | 41H | W | R | P | B | Interface type | | | | W = 0: Wait not used R = 1: Ready active P = 0: WP not used B = 0: BVS1 and BVD2 not used IF type = 1: I/O interface | Interface description field TPCE_IF | |
| 0AEH | 99H | M | MS | IR | IO | T | P | | | | M = 1: Misc info present MS = 00: No memory space info IR = 1: Interrupt info present IO = 1: I/O port info present T = 0: No timing info present P = 1: V _{cc} only info | Feature selection byte TPCE_FS |
| 0B0H | 01H | R | DI | PI | AI | SI | HV | LV | NV | Nominal voltage only follows R: Reserved DI: Power down Current info PI: Peak current info AI: Average current info SI: Static current info HV: Max voltage info LV: Min voltage info NV: Nominal voltage info | Power parameters for V _{cc} | |
| 0B2H | 55H | X | Mantissa | | | | Exponent | | | | Nominal voltage = 5 V | V _{cc} nominal value |
| 0B4H | 64H | R | S | E | IO AddrLine | | | | | | S = 1: 16-bit hosts supported E = 1: 8-bit hosts supported IO AddrLines: 4 lines decoded | I/O space description field TPCE_IO |
| 0B6H | F0H | S | P | L | M | V | B | I | N | S = 1: Share logic active P = 1: Pulse mode IRQ supported L = 1: Level mode IRQ supported M = 1: Bit mask of IRQs present V = 0: No vender unique IRQ B = 0: No bus error IRQ I = 0: No IO check IRQ N = 0: No NMI | Interrupt request description structure TPCE_IR | |

HB28J1000CCC/HB28J512CCC/HB28J256CCC/HB28J128CCC

| Address | Data | 7 | 6 | 5 | 4 | 3 | 2 | 1 | 0 | Description of contents | CIS function |
|---------|------|-----|----|----|----|----|----|----|------|---|---|
| 0B8H | FFH | IRQ | IR | IR | IR | IR | IR | IR | IRQ0 | IRQ level to be routed 0 to 15 recommended | Mask extension byte 1 TPCE_IR |
| | | 7 | Q | Q | Q | Q | Q | Q | Q | | |
| | | | 6 | 5 | 4 | 3 | 2 | 1 | | | |
| 0BAH | FFH | IRQ | IR | IR | IR | IR | IR | IR | IRQ8 | Recommended routing to any "normal, maskable" IRQ. | Mask extension byte 2 TPCE_IR |
| | | 15 | Q | Q | Q | Q | Q | Q | Q | | |
| | | | 14 | 13 | 12 | 11 | 10 | 9 | | | |
| 0BCH | 20H | X | R | P | RO | A | T | | | X = 0: No more misc fields R: reserved P = 1: Power down supported RO = 0: Not read only mode A = 0: Audio not supported T = 0: Single drive | Miscellaneous features field TPCE_MI |

HB28J1000CCC/HB28J512CCC/HB28J256CCC/HB28J128CCC

| Address | Data | 7 | 6 | 5 | 4 | 3 | 2 | 1 | 0 | Description of contents | CIS function | |
|---------|------|----------------------|-----------|---------------------|----|----|----------|--|----|--|---|--|
| 0BEH | 1BH | CISTPL_CFTABLE_ENTRY | | | | | | | | Configuration table entry tuple | Tuple code | |
| 0C0H | 06H | TPL_LINK | | | | | | | | Link length is 6 bytes | Link to next tuple | |
| 0C2H | 01H | I | D | Configuration index | | | | | | | Contiguous I/O mapped ATA registers configuration I = 0: No Interface byte D = 0: No Default entry Configuration index = 1 | Configuration table index byte TPCE_INDXX |
| 0C4H | 01H | M | MS | IR | IO | T | P | M = 0: No Misc info MS = 00: No Memory space info IR = 0: No interrupt info present IO = 0: No I/O port info present T = 0: No timing info present P = 1: V _{cc} only info | | | Feature selection byte TPCE_FS | |
| 0C6H | 21H | R | DI | PI | AI | SI | HV | LV | NV | Nominal voltage only follows R: Reserved DI: Power down current info PI: Peak current info AI: Average current info SI: Static current info HV: Max voltage info LV: Min voltage info NV: Nominal voltage info | Power parameters for V _{cc} | |
| 0C8H | B5H | X | Mantissa | | | | Exponent | | | Nominal voltage = 3.0 V | V _{cc} nominal value | |
| 0CAH | 1EH | X | Extension | | | | | | | | +0.3 V | Extension byte |
| 0CCH | 4DH | X | Mantissa | | | | Exponent | | | Max average current over 10 msec is 45 mA | Max. average current | |

HB28J1000CCC/HB28J512CCC/HB28J256CCC/HB28J128CCC

| Address | Data | 7 | 6 | 5 | 4 | 3 | 2 | 1 | 0 | Description of contents | CIS function | |
|---------|------|----------------------|----------|---------------------|-------------|----------------|----|---|---|--|---|---|
| 0CEH | 1BH | CISTPL_CFTABLE_ENTRY | | | | | | | | Configuration table entry tuple | Tuple code | |
| 0D0H | 0FH | TPL_LINK | | | | | | | | Link length is 15 bytes | Link to next tuple | |
| 0D2H | C2H | I | D | Configuration INDEX | | | | | | | ATA primary I/O mapped configuration I = 1: Interface byte follows D = 1: default entry follows Configuration index = 2 | Configuration table index byte TPCE_INDXX |
| 0D4H | 41H | W | R | P | B | Interface type | | | | W = 0: Wait not used R = 1: Ready active P = 0: WP not used B = 0: BVS1 and BVD2 not used IF type = 1: I/O interface | Interface description field TPCE_IF | |
| 0D6H | 99H | M | MS | IR | IO | T | P | | | | M = 1: misc info present MS = 00: No memory space info IR = 1: Interrupt info present IO = 1: I/O port info present T = 0: No timing info present P = 1: V _{cc} only info | Feature selection byte TPCE_FS |
| 0D8H | 01H | R | DI | PI | AI | SI | HV | LV | NV | Nominal voltage only follows R: Reserved DI: Power down Current info PI: Peak current info AI: Average current info SI: Static current info HV: Max voltage info LV: Min voltage info NV: Nominal voltage info | Power parameters for V _{cc} | |
| 0DAH | 55H | X | Mantissa | | Exponent | | | | Nominal voltage = 5 V | | | V _{cc} nominal value |
| 0DCH | EAH | R | S | E | IO AddrLine | | | | R = 1: Range follows S = 1: 16-bit hosts supported E = 1: 8-bit hosts supported IO AddrLines: 10 lines decoded | I/O space description field TPCE_IO | | |
| 0DEH | 61H | LS | AS | N range | | | | LS = 1: Size of lengths is 1 byte AS = 2: Size of address is 2 bytes N Range = 1: Address range - 1 | I/O range format description byte | | | |

HB28J1000CCC/HB28J512CCC/HB28J256CCC/HB28J128CCC

| Address | Data | 7 | 6 | 5 | 4 | 3 | 2 | 1 | 0 | Description of contents | CIS function | |
|---------|------|---|---|---|----|-----------|---|---|---|--|---|---|
| 0E0H | F0H | | | | | | | | | 1 st I/O base address (LSB) | 1 st I/O range address | |
| 0E2H | 01H | | | | | | | | | 1 st I/O base address (MSB) | | |
| 0E4H | 07H | | | | | | | | | 1 st I/O length - 1 | 1 st I/O range length | |
| 0E6H | F6H | | | | | | | | | 2 nd I/O base address (LSB) | 2 nd I/O range address | |
| 0E8H | 03H | | | | | | | | | 2 nd I/O base address (MSB) | | |
| 0EAH | 01H | | | | | | | | | 2 nd I/O length - 1 | 2 nd I/O range length | |
| 0ECH | EEH | S | P | L | M | IRQ level | | | | S = 1: Share logic active P = 1: Pulse mode IRQ supported L = 1: Level mode IRQ supported M = 0: Bit mask of IRQs present IRQ level is IRQ14 | Interrupt request description structure TPCE_IR | |
| 0EEH | 20H | X | R | P | RO | A | T | | | | X = 0: No more misc fields R: reserved P = 1: Power down supported RO = 0: Not read only mode A = 0: Audio not supported T = 0: Single drive | Miscellaneous features field TPCE_MI |

HB28J1000CCC/HB28J512CCC/HB28J256CCC/HB28J128CCC

| Address | Data | 7 | 6 | 5 | 4 | 3 | 2 | 1 | 0 | Description of contents | CIS function | |
|---------|------|----------------------|-----------|---------------------|----|----|----------|----|----|--|--|--|
| 0F0H | 1BH | CISTPL_CFTABLE_ENTRY | | | | | | | | Configuration table entry tuple | Tuple code | |
| 0F2H | 06H | TPL_LINK | | | | | | | | Link length is 6 bytes | Link to next tuple | |
| 0F4H | 02H | I | D | Configuration index | | | | | | | ATA primary I/O mapped configuration I = 0: No Interface byte D = 0: No Default entry Configuration index = 2 | Configuration table index byte TPCE_INDXX |
| 0F6H | 01H | M | MS | IR | IO | T | P | | | | M = 0: No Misc info MS = 00: No Memory space info IR = 0: No interrupt info present IO = 0: No I/O port info present T = 0: No timing info present P = 1: V _{cc} only info | Feature selection byte TPCE_FS |
| 0F8H | 21H | R | DI | PI | AI | SI | HV | LV | NV | Nominal voltage only follows R: Reserved DI: Power down current info PI: Peak current info AI: Average current info SI: Static current info HV: Max voltage info LV: Min voltage info NV: Nominal voltage info | Power parameters for V _{cc} | |
| 0FAH | B5H | X | Mantissa | | | | Exponent | | | Nominal voltage = 3.0 V | V _{cc} nominal value | |
| 0FCH | 1EH | X | Extension | | | | | | | | +0.3 V | Extension byte |
| 0FEH | 4DH | X | Mantissa | | | | Exponent | | | Max average current over 10 msec is 45 mA | Max. average current | |

HB28J1000CCC/HB28J512CCC/HB28J256CCC/HB28J128CCC

| Address | Data | 7 | 6 | 5 | 4 | 3 | 2 | 1 | 0 | Description of contents | CIS function | |
|---------|------|----------------------|----------|---------------------|-------------|----------------|----|---|---|--|---|---|
| 100H | 1BH | CISTPL_CFTABLE_ENTRY | | | | | | | | Configuration table entry tuple | Tuple code | |
| 102H | 0FH | TPL_LINK | | | | | | | | Link length is 15 bytes | Link to next tuple | |
| 104H | C3H | I | D | Configuration INDEX | | | | | | | ATA secondary I/O mapped configuration I = 1: Interface byte follows D = 1: default entry Configuration index = 3 | Configuration table index byte TPCE_INDXX |
| 106H | 41H | W | R | P | B | Interface type | | | | W = 0: Wait not used R = 1: Ready active P = 0: WP not used B = 0: BVS1 and BVD2 not used IF type = 1: I/O interface | Interface description field TPCE_IF | |
| 108H | 99H | M | MS | IR | IO | T | P | | | | M = 1: misc info present MS = 00: No memory space info IR = 1: Interrupt info present IO = 1: I/O port info present T = 0: No timing info present P = 1: V _{cc} only info | Feature selection byte TPCE_FS |
| 10AH | 01H | R | DI | PI | AI | SI | HV | LV | NV | Nominal voltage only follows R: Reserved DI: Power down Current info PI: Peak current info AI: Average current info SI: Static current info HV: Max voltage info LV: Min voltage info NV: Nominal voltage info | Power parameters for V _{cc} | |
| 10CH | 55H | X | Mantissa | | Exponent | | | | Nominal voltage = 5 V | | | V _{cc} nominal value |
| 10EH | EAH | R | S | E | IO AddrLine | | | | R = 1: Range follows S = 1: 16-bit hosts supported E = 1: 8-bit hosts supported IO AddrLines: 10 lines decoded | I/O space description field TPCE_IO | | |
| 110H | 61H | LS | AS | N range | | | | LS = 1: Size of lengths is 1 byte AS = 2: Size of address is 2 bytes N Range = 1: Address range - 1 | I/O range format description byte | | | |

HB28J1000CCC/HB28J512CCC/HB28J256CCC/HB28J128CCC

| Address | Data | 7 | 6 | 5 | 4 | 3 | 2 | 1 | 0 | Description of contents | CIS function |
|---------|------|---|---|---|----|-----------|---|---|---|---|--|
| 112H | 70H | | | | | | | | | 1 st I/O base address (LSB) | 1 st I/O range address |
| 114H | 01H | | | | | | | | | 1 st I/O base address (MSB) | |
| 116H | 07H | | | | | | | | | 1 st I/O length - 1 | 1 st I/O range length |
| 118H | 76H | | | | | | | | | 2 nd I/O base address (LSB) | 2 nd I/O range address |
| 11AH | 03H | | | | | | | | | 2 nd I/O base address (MSB) | |
| 11CH | 01H | | | | | | | | | 2 nd I/O length - 1 | 2 nd I/O range length |
| 11EH | EEH | S | P | L | M | IRQ level | | | | S = 1: Share logic active P = 1: Pulse mode IRQ supported L = 1: Level mode IRQ supported M = 0: Bit mask of IRQs present IRQ level is IRQ14 | Interrupt request description structure TPCE_IR |
| 120H | 20H | X | R | P | RO | A | T | | | X = 0: No more misc fields R: reserved P = 1: Power down supported RO = 0: Not read only mode A = 0: Audio not supported T = 0: Single drive | Miscellaneous features field TPCE_MI |

HB28J1000CCC/HB28J512CCC/HB28J256CCC/HB28J128CCC

| Address | Data | 7 | 6 | 5 | 4 | 3 | 2 | 1 | 0 | Description of contents | CIS function | | |
|---------|------|----------------------|-----------|---------------------|----|----|----------|----|----|--|--|--|----------------|
| 122H | 1BH | CISTPL_CFTABLE_ENTRY | | | | | | | | Configuration table entry tuple | Tuple code | | |
| 124H | 06H | TPL_LINK | | | | | | | | Link length is 6 bytes | Link to next tuple | | |
| 126H | 03H | I | D | Configuration index | | | | | | | ATA secondary I/O mapped configuration I = 0: No Interface byte D = 0: No Default entry Configuration index = 3 | Configuration table index byte TPCE_INDXX | |
| 128H | 01H | M | MS | IR | IO | T | P | | | | M = 0: No Misc info MS = 00: No Memory space info IR = 0: No interrupt info present IO = 0: No I/O port info present T = 0: No timing info present P = 1: V _{cc} only info | Feature selection byte TPCE_FS | |
| 12AH | 21H | R | DI | PI | AI | SI | HV | LV | NV | Nominal voltage only follows R: Reserved DI: Power down current info PI: Peak current info AI: Average current info SI: Static current info HV: Max voltage info LV: Min voltage info NV: Nominal voltage info | Power parameters for V _{cc} | | |
| 12CH | B5H | X | Mantissa | | | | Exponent | | | Nominal voltage = 3.0 V | V _{cc} nominal value | | |
| 12EH | 1EH | X | Extension | | | | | | | | | +0.3 V | Extension byte |
| 130H | 4DH | X | Mantissa | | | | Exponent | | | Max average current over 10 msec is 45 mA | Max. average current | | |
| 132H | 14H | CISTPL_NO_LINK | | | | | | | | No link control tuple | Tuple code | | |
| 134H | 00H | | | | | | | | | | Link is 0 bytes | Link to next tuple | |
| 136H | FFH | CISTPL_END | | | | | | | | End of list tuple | Tuple code | | |

Task File register specification

These registers are used for reading and writing the storage data in this card. These registers are mapped five types by the configuration of INDEX in Configuration Option register. The decoded addresses are shown as follows.

Memory map (INDEX = 0)

| -REG | A10 | A9 to A4 | A3 | A2 | A1 | A0 | Offset | -OE = L | -WE = L |
|------|-----|----------|----|----|----|----|--------|-------------------------|-------------------------|
| 1 | 0 | × | 0 | 0 | 0 | 0 | 0H | Data register | Data register |
| 1 | 0 | × | 0 | 0 | 0 | 1 | 1H | Error register | Feature register |
| 1 | 0 | × | 0 | 0 | 1 | 0 | 2H | Sector count register | Sector count register |
| 1 | 0 | × | 0 | 0 | 1 | 1 | 3H | Sector number register | Sector number register |
| 1 | 0 | × | 0 | 1 | 0 | 0 | 4H | Cylinder low register | Cylinder low register |
| 1 | 0 | × | 0 | 1 | 0 | 1 | 5H | Cylinder high register | Cylinder high register |
| 1 | 0 | × | 0 | 1 | 1 | 0 | 6H | Drive head register | Drive head register |
| 1 | 0 | × | 0 | 1 | 1 | 1 | 7H | Status register | Command register |
| 1 | 0 | × | 1 | 0 | 0 | 0 | 8H | Dup. even data register | Dup. even data register |
| 1 | 0 | × | 1 | 0 | 0 | 1 | 9H | Dup. odd data register | Dup. odd data register |
| 1 | 0 | × | 1 | 1 | 0 | 1 | DH | Dup. error register | Dup. feature register |
| 1 | 0 | × | 1 | 1 | 1 | 0 | EH | Alt. status register | Device control register |
| 1 | 0 | × | 1 | 1 | 1 | 1 | FH | Drive address register | Reserved |
| 1 | 1 | × | × | × | × | 0 | 8H | Even data register | Even data register |
| 1 | 1 | × | × | × | × | 1 | 9H | Odd data register | Odd data register |

HB28J1000CCC/HB28J512CCC/HB28J256CCC/HB28J128CCC**Contiguous I/O map (INDEX = 1)**

| -REG | A10 to A4 | A3 | A2 | A1 | A0 | Offset | -IORD = L | -IOWR = L |
|-------------|------------------|-----------|-----------|-----------|-----------|---------------|-------------------------|-------------------------|
| 0 | × | 0 | 0 | 0 | 0 | 0H | Data register | Data register |
| 0 | × | 0 | 0 | 0 | 1 | 1H | Error register | Feature register |
| 0 | × | 0 | 0 | 1 | 0 | 2H | Sector count register | Sector count register |
| 0 | × | 0 | 0 | 1 | 1 | 3H | Sector number register | Sector number register |
| 0 | × | 0 | 1 | 0 | 0 | 4H | Cylinder low register | Cylinder low register |
| 0 | × | 0 | 1 | 0 | 1 | 5H | Cylinder high register | Cylinder high register |
| 0 | × | 0 | 1 | 1 | 0 | 6H | Drive head register | Drive head register |
| 0 | × | 0 | 1 | 1 | 1 | 7H | Status register | Command register |
| 0 | × | 1 | 0 | 0 | 0 | 8H | Dup. even data register | Dup. even data register |
| 0 | × | 1 | 0 | 0 | 1 | 9H | Dup. odd data register | Dup. odd data register |
| 0 | × | 1 | 1 | 0 | 1 | DH | Dup. error register | Dup. feature register |
| 0 | × | 1 | 1 | 1 | 0 | EH | Alt. status register | Device control register |
| 0 | × | 1 | 1 | 1 | 1 | FH | Drive address register | Reserved |

Primary I/O map (INDEX = 2)

| -REG | A10 | A9 to A4 | A3 | A2 | A1 | A0 | -IORD = L | -IOWR = L |
|-------------|------------|-----------------|-----------|-----------|-----------|-----------|------------------------|-------------------------|
| 0 | × | 1FH | 0 | 0 | 0 | 0 | Data register | Data register |
| 0 | × | 1FH | 0 | 0 | 0 | 1 | Error register | Feature register |
| 0 | × | 1FH | 0 | 0 | 1 | 0 | Sector count register | Sector count register |
| 0 | × | 1FH | 0 | 0 | 1 | 1 | Sector number register | Sector number register |
| 0 | × | 1FH | 0 | 1 | 0 | 0 | Cylinder low register | Cylinder low register |
| 0 | × | 1FH | 0 | 1 | 0 | 1 | Cylinder high register | Cylinder high register |
| 0 | × | 1FH | 0 | 1 | 1 | 0 | Drive head register | Drive head register |
| 0 | × | 1FH | 0 | 1 | 1 | 1 | Status register | Command register |
| 0 | × | 3FH | 0 | 1 | 1 | 0 | Alt. status register | Device control register |
| 0 | × | 3FH | 0 | 1 | 1 | 1 | Drive address register | Reserved |

HB28J1000CCC/HB28J512CCC/HB28J256CCC/HB28J128CCC**Secondary I/O map (INDEX = 3)**

| -REG | A10 | A9 to A4 | A3 | A2 | A1 | A0 | -IORD = L | -IOWR = L |
|-------------|------------|-----------------|-----------|-----------|-----------|-----------|------------------------|-------------------------|
| 0 | × | 17H | 0 | 0 | 0 | 0 | Data register | Data register |
| 0 | × | 17H | 0 | 0 | 0 | 1 | Error register | Feature register |
| 0 | × | 17H | 0 | 0 | 1 | 0 | Sector count register | Sector count register |
| 0 | × | 17H | 0 | 0 | 1 | 1 | Sector number register | Sector number register |
| 0 | × | 17H | 0 | 1 | 0 | 0 | Cylinder low register | Cylinder low register |
| 0 | × | 17H | 0 | 1 | 0 | 1 | Cylinder high register | Cylinder high register |
| 0 | × | 17H | 0 | 1 | 1 | 0 | Drive head register | Drive head register |
| 0 | × | 17H | 0 | 1 | 1 | 1 | Status register | Command register |
| 0 | × | 37H | 0 | 1 | 1 | 0 | Alt. status register | Device control register |
| 0 | × | 37H | 0 | 1 | 1 | 1 | Drive address register | Reserved |

True IDE Mode I/O map

| -CS1 | -CS0 | A2 | A1 | A0 | -IORD = L | -IOWR = L |
|-------------|-------------|-----------|-----------|-----------|------------------------|-------------------------|
| 1 | 0 | 0 | 0 | 0 | Data register | Data register |
| 1 | 0 | 0 | 0 | 1 | Error register | Feature register |
| 1 | 0 | 0 | 1 | 0 | Sector count register | Sector count register |
| 1 | 0 | 0 | 1 | 1 | Sector number register | Sector number register |
| 1 | 0 | 1 | 0 | 0 | Cylinder low register | Cylinder low register |
| 1 | 0 | 1 | 0 | 1 | Cylinder high register | Cylinder high register |
| 1 | 0 | 1 | 1 | 0 | Drive head register | Drive head register |
| 1 | 0 | 1 | 1 | 1 | Status register | Command register |
| 0 | 1 | 1 | 1 | 0 | Alt. status register | Device control register |
| 0 | 1 | 1 | 1 | 1 | Drive address register | Reserved |

HB28J1000CCC/HB28J512CCC/HB28J256CCC/HB28J128CCC

- 1. Data register:** This register is a 16-bit register that has read/write ability, and it is used for transferring 1 sector data between the card and the host. This register can be accessed in word mode and byte mode. This register overlaps the Error or Feature register.

| bit15 | bit14 | bit13 | bit12 | bit11 | bit10 | bit9 | bit8 | bit7 | bit6 | bit5 | bit4 | bit3 | bit2 | bit1 | bit0 |
|-----------|-------|-------|-------|-------|-------|------|------|------|------|------|------|------|------|------|------|
| D0 to D15 | | | | | | | | | | | | | | | |

- 2. Error register:** This register is a read only register, and it is used for analyzing the error content at the card accessing. This register is valid when the BSY bit in Status register and Alternate Status register are set to "0" (Ready).

| bit7 | bit6 | bit5 | bit4 | bit3 | bit2 | bit1 | bit0 |
|------|------|------|------|------|------|------|------|
| BBK | UNC | "0" | IDNF | "0" | ABRT | "0" | AMNF |

| bit | Name | Function |
|-----|-------------------------------|---|
| 7 | BBK (Bad BloCk detected) | This bit is set when a Bad Block is detected in requested ID field. |
| 6 | UNC (Data ECC error) | This bit is set when Uncorrectable error is occurred at reading the card. |
| 4 | IDNF (ID Not Found) | The requested sector ID is in error or cannot be found. |
| 2 | ABRT (ABoRTed command) | This bit is set if the command has been aborted because of the card status condition. (Not ready, Write fault, Invalid command, etc.) |
| 0 | AMNF (Address Mark Not Found) | This bit is set in case of a general error. |

- 3. Feature register:** This register is a write only register, and provides information regarding features of the drive which the host wishes to utilize.

| bit7 | bit6 | bit5 | bit4 | bit3 | bit2 | bit1 | bit0 |
|--------------|------|------|------|------|------|------|------|
| Feature byte | | | | | | | |

- 4. Sector count register:** This register contains the numbers of sectors of data requested to be transferred on a read or write operation between the host and the card. If the value of this register is zero, a count of 256 sectors is specified. In plural sector transfer, if not successfully completed, the register contains the number of sectors which need to be transferred in order to complete the request. This register's initial value is "01H".

| bit7 | bit6 | bit5 | bit4 | bit3 | bit2 | bit1 | bit0 |
|-------------------|------|------|------|------|------|------|------|
| Sector count byte | | | | | | | |

HB28J1000CCC/HB28J512CCC/HB28J256CCC/HB28J128CCC

5. Sector number register: This register contains the starting sector number which is started by following sector transfer command.

| | | | | | | | |
|--------------------|-------------|-------------|-------------|-------------|-------------|-------------|-------------|
| bit7 | bit6 | bit5 | bit4 | bit3 | bit2 | bit1 | bit0 |
| Sector number byte | | | | | | | |

6. Cylinder low register: This register contains the low 8-bit of the starting cylinder address which is started by following sector transfer command.

| | | | | | | | |
|-------------------|-------------|-------------|-------------|-------------|-------------|-------------|-------------|
| bit7 | bit6 | bit5 | bit4 | bit3 | bit2 | bit1 | bit0 |
| Cylinder low byte | | | | | | | |

7. Cylinder high register: This register contains the high 8-bit of the starting cylinder address which is started by following sector transfer command.

| | | | | | | | |
|--------------------|-------------|-------------|-------------|-------------|-------------|-------------|-------------|
| bit7 | bit6 | bit5 | bit4 | bit3 | bit2 | bit1 | bit0 |
| Cylinder high byte | | | | | | | |

8. Drive head register: This register is used for selecting the Drive number and head number for the following command.

| | | | | | | | |
|-------------|-------------|-------------|-------------|-------------|-------------|-------------|-------------|
| bit7 | bit6 | bit5 | bit4 | bit3 | bit2 | bit1 | bit0 |
| 1 | LBA | 1 | DRV | Head number | | | |

Note: DRV: Drive number
Head number: Head number

| bit | Name | Function |
|------------|--------------------|---|
| 7 | 1 | This bit is set to "1". |
| 6 | LBA | LBA is a flag to select either Cylinder / Head / Sector (CHS) or Logical Block Address (LBA) mode. When LBA = 0, CHS mode is selected. When LBA = 1, LBA mode is selected. In LBA mode, the Logical Block Address is interrupted as follows: LBA07 - LBA00: Sector Number Register D7 - D0. LBA15 - LBA08: Cylinder Low Register D7 - D0. LBA23 - LBA16: Cylinder High Register D7 - D0. LBA27 - LBA24: Drive / Head Register bits HS3 - HS0. |
| 5 | 1 | This bit is set to "1". |
| 4 | DRV (DRiVe select) | This bit is used for selecting the Master (Card 0) and Slave (Card 1) in Master/Slave organization. The card is set to be Card 0 or 1 by using DRV# of the Socket and Copy register. |
| 3 to 0 | Head number | This bit is used for selecting the Head number for the following command. Bit 3 is MSB. |

9. Status register: This register is read only register, and it indicates the card status of command execution. When this register is read in configured I/O card mode (INDEX = 1, 2, 3) and level interrupt mode, -IREQ is negated. This register should be accessed in byte mode. In word mode, it is recommended that Alternate status register may be used as this register.

| bit7 | bit6 | bit5 | bit4 | bit3 | bit2 | bit1 | bit0 |
|------|------|------|------|------|------|------|------|
| BSY | DRDY | DWF | DSC | DRQ | CORR | IDX | ERR |

| bit | Name | Function |
|-----|---------------------------|--|
| 7 | BSY (BuSY) | This bit is set when the card internal operation is executing. When this bit is set to "1", other bits in this register are invalid. |
| 6 | DRDY (Drive ReaDY) | If this bit and DSC bit are set to "1", the card is capable of receiving the read or write or seek requests. If this bit is set to "0", the card prohibits these requests. |
| 5 | DWF (Drive Write Fault) | This bit is set if this card indicates the write fault status. |
| 4 | DSC (Drive Seek Complete) | This bit is set when the drive seek complete. |
| 3 | DRQ (Data ReQuest) | This bit is set when the information can be transferred between the host and Data register. This bit is cleared when the card receives the other command. |
| 2 | CORR (CORReCted data) | This bit is set when a correctable data error has been occurred and the data has been corrected. |
| 1 | IDX (InDeX) | This bit is always set to "0". |
| 0 | ERR (ERRor) | This bit is set when the previous command has ended in some type of error. The error information is set in the other Status register or Error register. This bit is cleared by the next command. |

10. Alternate status register: This register is the same as Status register in physically, so the bit assignment refers to previous item of Status register. But this register is different from Status register that -IREQ is not negated when data read.

11. Command register: This register is write only register, and it is used for writing the command at executing the drive operation. The command code written in the command register, after the parameter is written in the Task File during the card is Ready state.

Parameter

- FR: Feature register
- SC: Sector Count register
- SN: Sector Number register
- CY: Cylinder register
- DR: DRV bit of Drive Head register
- HD: Head Number of Drive Head register
- LBA: Logical Block Address Mode Supported

HB28J1000CCC/HB28J512CCC/HB28J256CCC/HB28J128CCC

12. Device control register: This register is write only register, and it is used for controlling the card interrupt request and issuing an ATA soft reset to the card.

| bit7 | bit6 | bit5 | bit4 | bit3 | bit2 | bit1 | bit0 |
|------|------|------|------|------|------|------|------|
| × | × | × | × | 1 | SRST | nIEN | 0 |

| bit | Name | Function |
|--------|-------------------------|---|
| 7 to 4 | × | don't care |
| 3 | 1 | This bit is set to "1". |
| 2 | SRST (Software ReSet) | This bit is set to "1" in order to force the card to perform Task File Reset operation. This does not change the Card Configuration registers as a Hardware Reset does. The card remains in Reset until this bit is reset to "0". |
| 1 | nIEN (Interrupt ENable) | This bit is used for enabling -IREQ. When this bit is set to "0", -IREQ is enabled. When this bit is set to "1", -IREQ is disabled. |
| 0 | 0 | This bit is set to "0". |

13. Drive Address register: This register is read only register, and it is used for confirming the drive status. This register is provides for compatibility with the AT disk drive interface. It is recommended that this register is not mapped into the host's I/O space because of potential conflicts on bit7.

| bit7 | bit6 | bit5 | bit4 | bit3 | bit2 | bit1 | bit0 |
|------|------|------|------|------|------|------|------|
| × | nWTG | nHS3 | nHS2 | nHS1 | nHS0 | nDS1 | nDS0 |

| bit | Name | Function |
|--------|-------------------------|--|
| 7 | × | This bit is unknown. |
| 6 | nWTG (WriTing Gate) | This bit is unknown. |
| 5 to 2 | nHS3-0 (Head Select3-0) | These bits are the negative value of Head Select bits (bit 3 to 0) in Drive/Head register. |
| 1 | nDS1 (Idrive Select1) | This bit is unknown. |
| 0 | nDS0 (Idrive Select0) | This bit is unknown. |

ATA Command specifications

This table summarizes the ATA command set with the paragraphs. Following shows the support commands and command codes which are written in command registers.

ATA Command Set

| No. | Command set | Code | FR | SC | SN | CY | DR | HD | LBA |
|-----|-----------------------------|------------|----|----|----|----|----|----|-----|
| 1 | Check power mode | E5H or 98H | — | — | — | — | Y | — | — |
| 2 | Execute drive diagnostic | 90H | — | — | — | — | Y | — | — |
| 3 | Erase sector(s) | C0H | — | Y | Y | Y | Y | Y | Y |
| 4 | Format track | 50H | — | Y | — | Y | Y | Y | Y |
| 5 | Identify Drive | ECH | — | — | — | — | Y | — | — |
| 6 | Idle | E3H or 97H | — | Y | — | — | Y | — | — |
| 7 | Idle immediate | E1H or 95H | — | — | — | — | Y | — | — |
| 8 | Initialize drive parameters | 91H | — | Y | — | — | Y | Y | — |
| 9 | Read buffer | E4H | — | — | — | — | Y | — | — |
| 10 | Read multiple | C4H | — | Y | Y | Y | Y | Y | Y |
| 11 | Read long sector | 22H, 23H | — | — | Y | Y | Y | Y | Y |
| 12 | Read sector (s) | 20H, 21H | — | Y | Y | Y | Y | Y | Y |
| 13 | Read verify sector (s) | 40H, 41H | — | Y | Y | Y | Y | Y | Y |
| 14 | Recalibrate | 1XH | — | — | — | — | Y | — | — |
| 15 | Request sense | 03H | — | — | — | — | Y | — | — |
| 16 | Seek | 7XH | — | — | Y | Y | Y | Y | Y |
| 17 | Set features | EFH | Y | — | — | — | Y | — | — |
| 18 | Set multiple mode | C6H | — | Y | — | — | Y | — | — |
| 19 | Set sleep mode | E6H or 99H | — | — | — | — | Y | — | — |
| 20 | Stand by | E2H or 96H | — | — | — | — | Y | — | — |
| 21 | Stand by immediate | E0H or 94H | — | — | — | — | Y | — | — |
| 22 | Translate sector | 87H | — | Y | Y | Y | Y | Y | Y |
| 23 | Wear level | F5H | — | — | — | — | Y | Y | — |

HB28J1000CCC/HB28J512CCC/HB28J256CCC/HB28J128CCC

| No. | Command set | Code | FR | SC | SN | CY | DR | HD | LBA |
|-----|---------------------------|------------|----|----|----|----|----|----|-----|
| 24 | Write buffer | E8H | — | — | — | — | Y | — | — |
| 25 | Write long sector | 32H or 33H | — | — | Y | Y | Y | Y | Y |
| 26 | Write multiple | C5H | — | Y | Y | Y | Y | Y | Y |
| 27 | Write multiple w/o erase | CDH | — | Y | Y | Y | Y | Y | Y |
| 28 | Write sector | 30H or 31H | — | Y | Y | Y | Y | Y | Y |
| 29 | Write sector(s) w/o erase | 38H | — | Y | Y | Y | Y | Y | Y |
| 30 | Write verify | 3CH | — | Y | Y | Y | Y | Y | Y |

Note: FR: Feature Register
SC: Sector Count register (00H to FFH)
SN: Sector Number register (01H to 20H)
CY: Cylinder Low/High register (to)
DR: Drive bit of Drive/Head register
HD: Head No. (0 to 3) of Drive/Head register
NH: No. of Heads
Y: Set up
—: Not set up

1. Check Power Mode (code: E5H or 98H): This command checks the power mode.
2. Execute Drive Diagnostic (code: 90H): This command performs the internal diagnostic tests implemented by the Card.
3. Erase Sector(s) (code: C0H): This command is used to erase data sectors.
4. Format Track (code: 50H): This command writes the desired head and cylinder of the selected drive. But selected sector data is not exchange. This card expects a sector buffer of data from the host to follow the command with same protocol as the Write Sector command.
5. Identify Drive (code: ECH): This command enables the host to receive parameter information from the Card

Identify Drive Information

| Word address | Default value | Total bytes | Data field type information |
|---------------------|----------------------|--------------------|---|
| 0 | 848AH | 2 | General configuration bit-significant information |
| 1 | XXXXH | 2 | Default number of cylinders |
| 2 | 0000H | 2 | Reserved |
| 3 | 00XXH | 2 | Default number of heads |
| 4 | 0000H | 2 | Obsolete |
| 5 | XXXXH | 2 | Obsolete |
| 6 | XXXXH | 2 | Default number of sectors per track |
| 7 to 8 | XXXXH | 4 | Number of sectors per card (Word7 = MSW, Word8 = LSW) |
| 9 | 0000H | 2 | Obsolete |
| 10 to 19 | XXXXH | 20 | Serial number in ASCII (Right justified) |
| 20 | 0002H | 2 | Obsolete |
| 21 | 0002H | 2 | Obsolete |
| 22 | 0004H | 2 | # of ECC bytes passed on Read/Write Long Commands |
| 23 to 26 | XXXXH | 8 | Firmware revision in ASCII. Big Endian Byte Order in Word |
| 27 to 46 | XXXXH | 40 | Model number in ASCII (Left justified) Big Endian Byte Order in Word |
| 47 | 0001H | 2 | Maximum number of sectors on Read/Write Multiple command |
| 48 | 0000H | 2 | Reserved |
| 49 | 0200H | 2 | Capabilities: LBA supported (bit9) |
| 50 | 0000H | 2 | Reserved |
| 51 | 0200H | 2 | PIO data transfer cycle timing mode |
| 52 | 0000H | 2 | Obsolete |
| 53 | 0003H | 2 | Translation Parameters Valid (bit0: Word54 to 58 are valid, bit1: Word64 to 70 are valid) |
| 54 | XXXXH | 2 | Current numbers of cylinders |
| 55 | XXXXH | 2 | Current numbers of heads |
| 56 | XXXXH | 2 | Current numbers per track |
| 57 to 58 | XXXXH | 4 | Current capacity in sectors (LBAs) (Word57 = LSW, Word58 = MSW) |
| 59 | 010XH | 2 | Multiple sector setting |
| 60 to 61 | XXXXH | 4 | Total number of sectors addressable in LBA Mode |
| 62 to 63 | 0000H | 4 | Reserved |

HB28J1000CCC/HB28J512CCC/HB28J256CCC/HB28J128CCC

| Word address | Default value | Total bytes | Data field type information |
|--------------|---------------|-------------|--|
| 64 | 0003H | 2 | Advanced PIO Modes supported (bit0: PIO-3, bit1: PIO-4 supported) |
| 65 to 66 | 0000H | 4 | Reserved |
| 67 | 0078H | 2 | Minimum PIO transfer cycle time without flow control |
| 68 | 0078H | 2 | Minimum PIO transfer cycle time with IORDY flow control |
| 69 to 79 | 0000H | 20 | Reserved |
| 80 to 81 | 0000H | 4 | Reserved for CFA |
| 82 | 7000H | 2 | Features/command sets supported 15: Obsolete 14: 1 = NOP command supported 13: 1 = Read buffer command supported 12: 1 = Write buffer command supported 11: Obsolete 10: 0 = Host protected area feature set not supported 9: 0 = Device reset command not supported 8: 0 = Service interrupt not supported 7: 0 = Release interrupt not supported 6: 0 = Look-ahead not supported 5: 0 = Write cache not supported 4: 0 = PACKET command feature set not supported 3: 0 = Power management feature set not supported 2: 0 = Removable media feature set not supported 1: 0 = Security mode feature set not supported 0: 0 = Smart feature set not supported |
| 83 | 4004H | 2 | Features/command sets supported 15: Shall be cleared to zero 14: Shall be set to one 13 to 7: Reserved 6: 0 = Set features subcommand required to spin up after power-up (not supported) 5: 0 = Power-up in standby feature set not supported 4: 0 = Removable media status notification feature set not supported 3: Advanced power management feature set not supported 2: 1 = CFA feature set supported 1: 0 = Read/Write DMA queued command not supported 0: 0 = Download microcode command not supported |
| 84 | 4000H | 2 | Features/command sets supported |

HB28J1000CCC/HB28J512CCC/HB28J256CCC/HB28J128CCC

| Word address | Default value | Total bytes | Data field type information |
|--------------|---------------|-------------|--|
| 85 | 7000H | 2 | Features/command sets enabled 15: Obsolete 14: 1 = NOP command supported 13: 1 = Read buffer command supported 12: 1 = Write buffer command supported 11: Obsolete 10: 0 = Host protected area feature set not supported 9: 0 = Device reset command not supported 8: 0 = Service interrupt disabled 7: 0 = Release interrupt disabled 6: 0 = Look-ahead not supported 5: 0 = Write cache not supported 4: 0 = PACKET command feature set not supported 3: 0 = Power management feature set not supported 2: 0 = Removable media feature set not supported 1: 0 = Security mode feature set disabled 0: 0 = Smart feature set enabled disabled |
| 86 | 0004H | 2 | Features/command sets enabled 15 to 7: Reserved 6: 0 = Set features subcommand required to spin up after power-up (not supported) 5: 0 = Power-up in standby feature set disabled 4: 0 = Removable media status notification feature set disabled 3: 0 = Advanced power management feature set disabled 2: 1 = CFA feature set supported 1: 0 = Read/Write DMA queued command not supported 0: 0 = Download microcode command not supported |
| 87 | 4000H | 2 | Features/command sets enabled 15: Shall be cleared to zero 14: Shall be set to one 13 to 0: Reserved |
| 88 | 0000H | 2 | Reserved |
| 89 | 0000H | 2 | Time required for Security erase unit completion |
| 90 | 0000H | 2 | Time required for Enhanced security erase unit completion |
| 91 | XXXXH | 2 | Current Advanced power management value |
| 92 to 127 | 0000H | 72 | Reserved |
| 128 | 0000H | 2 | Security status |
| 129 to 159 | 0000H | 64 | Vendor unique bytes |
| 160 | 0000H | 2 | Power requirement description |
| 161 | 0000H | 2 | Reserved |
| 162 | 0000H | 2 | Key management schemes supported |
| 163 to 255 | 0000H | 166 | Reserved |

HB28J1000CCC/HB28J512CCC/HB28J256CCC/HB28J128CCC

6. Idle (code: E3H or 97H): This command causes the PC Card to set BSY, enter the Idle mode, clear BSY and generate an interrupt. If sector count is non-zero, the automatic power down mode is enabled. If the sector count is zero, the automatic power down mode is disabled.
7. Idle Immediate (code: E1H or 95H): This command causes the Card to set BSY, enter the Idle (Read) mode, clear BSY and generate an interrupt.
8. Initialize Drive Parameters (code: 91H): This command enables the host to set the number of sectors per track and the number of heads per cylinder.
9. Read Buffer (code: E4H): This command enables the host to read the current contents of the PC card's sector buffer.
10. Read Multiple (code: C4h): This command performs similarly to the Read Sectors command. Interrupts are not generated on each sector, but on the transfer of a block which contains the number of sectors defined by a Set Multiple command.
11. Read Long Sector (code: 22h or 23h): This command performs similarly to the Read Sector(s) command except that it returns 516 bytes of data instead of 512 bytes.
12. Read Sector(s) (code: 20h, 21h): This command reads from 1 to 256 sectors as specified in the Sector Count register. A sector count of 0 requests 256 sectors. The transfer begins at the sector specified in the Sector Number register.
13. Read Verify Sector(s) (code: 40h or 41h): This command is identical to the Read Sectors command, except that DRQ is never set and no data is transferred to the host.
14. Recalibrate (code: 1Xh): This command is effectively a NOP command to the Card and is provided for compatibility purposes.
15. Request Sense (code: 03h): This command requests an extended error code after command ends with an error.
16. Seek (code: 7Xh): This command is effectively a NOP command to the Card although it does perform a range check.
17. Set Features (code: EFH): This command is used by the host to establish or select certain features.

| Feature | Operation |
|----------------|--|
| 01H | Enable 8-bit data transfers. |
| 55H | Disable Read Look Ahead. |
| 66H | Disable Power on Reset(POR) establishment of defaults at Soft Reset. |
| 81H | Disable 8-bit data transfer. |
| BBH | 4bytes of data apply on Read/Write Long commands. |
| CCH | Enable Power on Reset(POR) establishment of default at Soft Reset. |

18. Set Multiple Mode (code: C6h): This command enables the Card to perform Read and Write Multiple operations and establishes the block count for these commands.
19. Set Sleep Mode (code: E6h or 99h): This command causes the Card to set BSY, enter the Sleep mode, clear BSY and generate an interrupt.
20. Stand By (code: E2h or 96h): This command causes the Card to set BSY, enter the Sleep mode (which corresponds to the ATA “Standby” Mode), clear BSY and return the interrupt immediately.
21. Stand By Immediate (code: E0h or 94h): This command causes the Card to set BSY, enter the Sleep mode (which corresponds to the ATA “Standby” Mode), clear BSY and return the interrupt immediately.
22. Translate Sector (code: 87h): This card does not support by this command the function of determining the exact number of times a user sector has been erased and programmed because this card always responds with “00H”, though this command could provide information containing the desired cylinder, head and sector, including its Logical Address, etc.
23. Wear level (code: F5h): This command is effectively a NOP command and only implemented for backward compatibility. The Sector Count Register will always be returned with an 00H indicating Wear Level is not needed.
24. Write Buffer (code: E8h): This command enables the host to overwrite contents of the Card’s sector buffer with any data pattern desired.
25. Write Long Sector (code: 32h or 33h): This command is provided for compatibility purposes and is similar to the Write Sector(s) command except that it writes 516 bytes instead of 512 bytes.
26. Write Multiple (code: C5h): This command is similar to the Write Sectors command. Interrupts are not presented on each sector, but on the transfer of a block which contains the number of sectors defined by Set Multiple command.
27. Write Multiple without Erase (code: CDh): This command is similar to the Write Multiple command with the exception that an implied erase before write operation is not performed.
28. Write Sector(s) (code: 30h or 31h): This command writes from 1 to 256 sectors as specified in the Sector Count register. A sector count of zero requests 256 sectors. The transfer begins at the sector specified in the Sector Number register.
29. Write Sector(s) without Erase (code: 38h): This command is similar to the Write Sector(s) command with the exception that an implied erase before write operation is not performed.
30. Write Verify (code: 3Ch): This command is similar to the Write Sector(s) command, except each sector is verified immediately after being written.

Sector Transfer Protocol

1. Sector read: 1 sector read procedure after the card configured I/O interface is shown as follows.

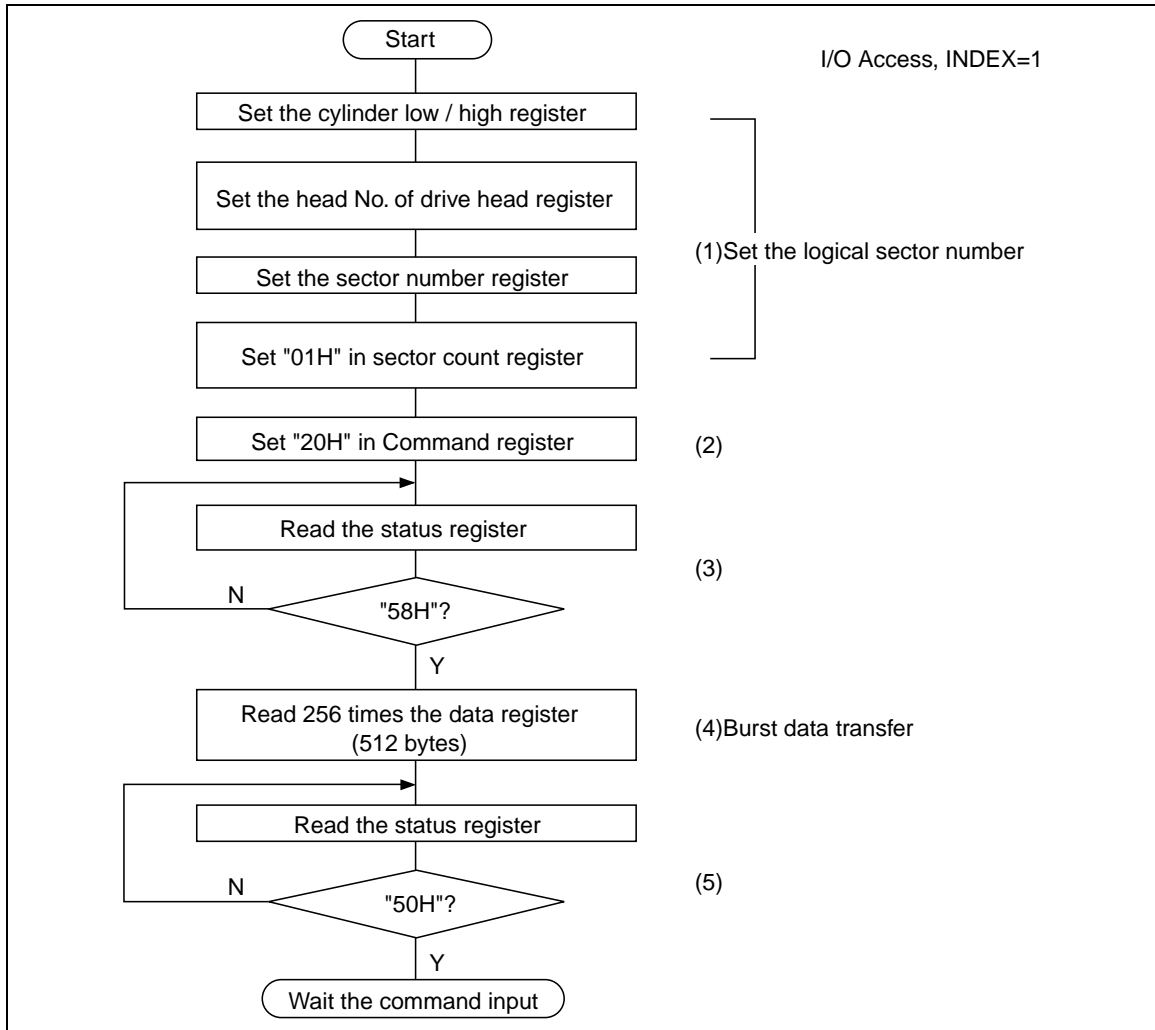

HB28J1000CCC/HB28J512CCC/HB28J256CCC/HB28J128CCC

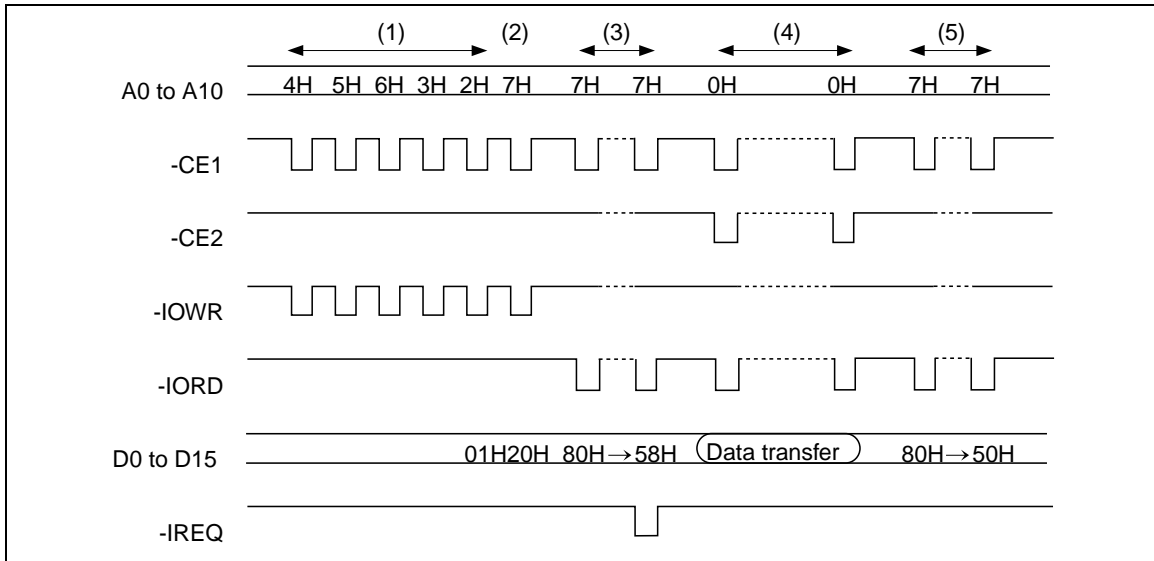

2. Sector write: 1 sector write procedure after the card configured I/O interface is shown as follows.

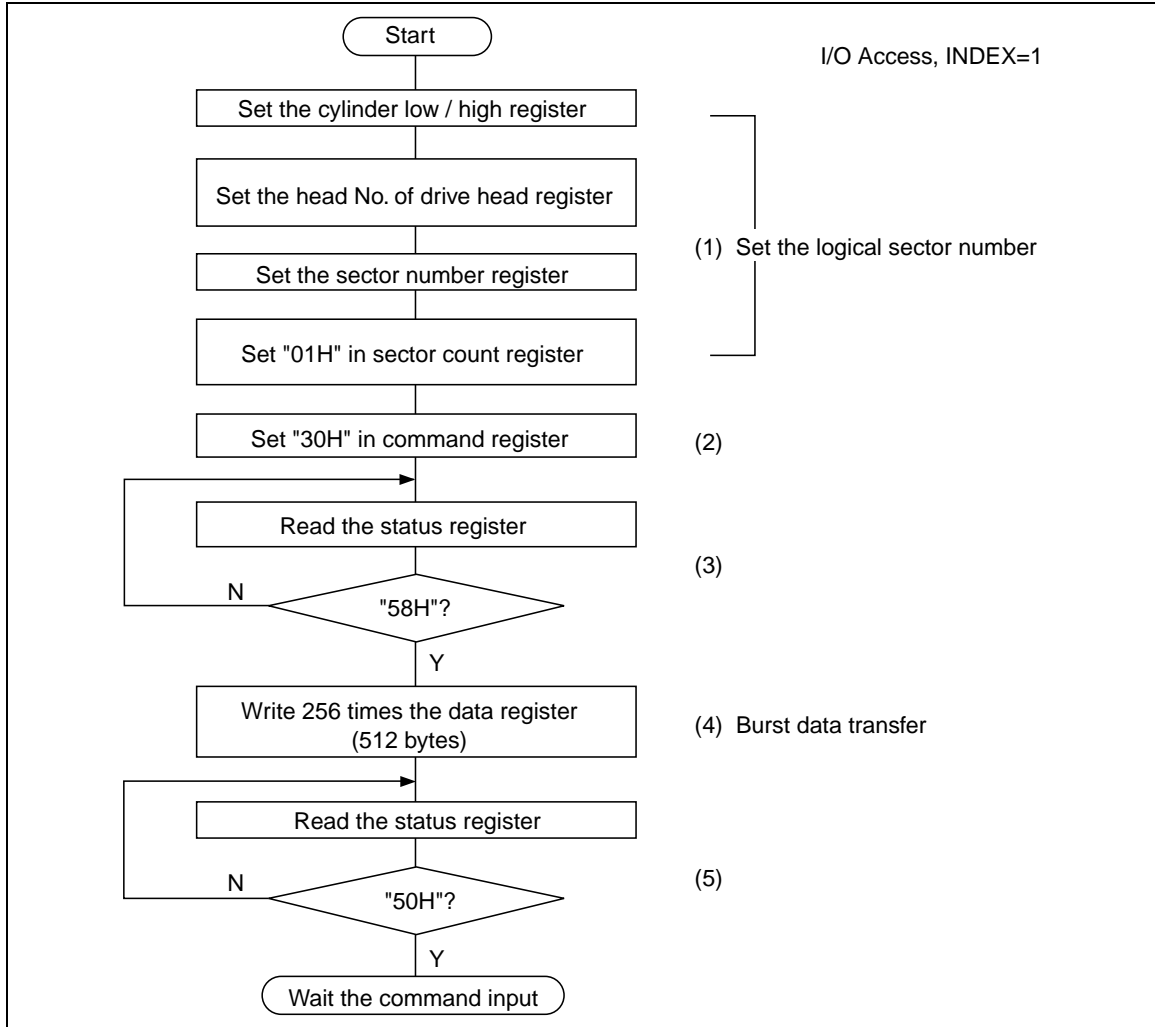

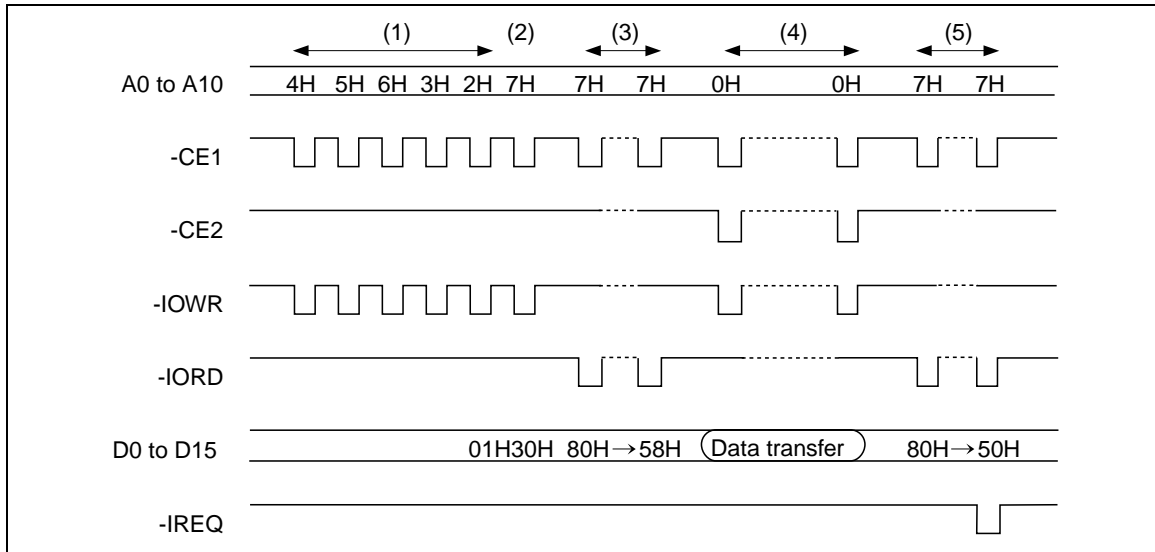

Absolute Maximum Ratings

| Parameter | Symbol | Value | Unit | Note |
|-----------------------------|------------------------------------|-------------------------------|------|------|
| All input/output voltages | V _{in} , V _{out} | -0.3 to V _{cc} + 0.3 | V | 1 |
| V _{cc} voltage | V _{cc} | -0.3 to +6.5 | V | |
| Operating temperature range | T _{opr} | 0 to +60 | °C | |
| Storage temperature range | T _{stg} | -20 to +65 | °C | |

Note: 1. V_{in}, V_{out} min = -2.0 V for pulse width ≤ 20 ns.

Recommended Operating Conditions

| Parameter | Symbol | Min | Typ | Max | Unit |
|-------------------------|-----------------|-----------|-----|-----------|------|
| Operating temperature | T _a | 0 | +25 | +60 | °C |
| V _{cc} voltage | V _{cc} | 5.0 – 10% | 5.0 | 5.0 + 10% | V |
| | | 3.3 – 5% | 3.3 | 3.3 + 5% | V |

Capacitance (T_a = +25°C, f = 1MHz)

| Parameter | Symbol | Min | Typ | Max | Unit | Test conditions |
|--------------------|------------------|-----|-----|-----|------|------------------------|
| Input capacitance | C _{in} | — | — | 35 | pF | V _{in} = 0 V |
| Output capacitance | C _{out} | — | — | 35 | pF | V _{out} = 0 V |

System Performance

| Item | Performance |
|---|-----------------|
| Set up times (Reset to ready) | 100 ms (max) |
| Set up times (Sleep to idle) | 2 ms (max) |
| Data transfer rate to/from host | 16.6 MB/s burst |
| Controller overhead (Command to DRQ) | 2 ms (max) |
| Data transfer cycle end to ready (Sector write) | 2 ms (typ) |

HB28J1000CCC/HB28J512CCC/HB28J256CCC/HB28J128CCC

DC Characteristics-1 ($T_a = 0$ to $+60^\circ\text{C}$, $V_{CC} = 5\text{ V} \pm 10\%$, $3.3\text{ V} \pm 5\%$)

| Parameter | Symbol | Min | Typ | Max | Unit | Test conditions | Note |
|-----------------------|----------|----------------|-----|---------|---------------|----------------------------------|------|
| Input leakage current | I_{LI} | — | — | ± 1 | μA | $V_{in} = \text{GND to } V_{CC}$ | 1 |
| Output voltage | V_{OL} | — | — | 0.4 | V | $I_{OL} = 8\text{ mA}$ | |
| | V_{OH} | $V_{CC} - 0.8$ | — | — | V | $I_{OH} = -8\text{ mA}$ | |

Note: 1. Except pulled up input pin.

| Parameter | Symbol | 3.3 V | | | 5 V | | | Unit | Test conditions |
|---------------------------------|----------|-------|-----|-----|-----|-----|-----|------|-----------------|
| | | Min | Typ | Max | Min | Typ | Max | | |
| Input voltage (CMOS) | V_{IL} | — | — | 0.6 | — | — | 0.8 | V | |
| | V_{IH} | 2.4 | — | — | 4.0 | — | — | V | |
| Input voltage (Schmitt trigger) | V_{IL} | — | 1.0 | — | — | 2.0 | — | V | |
| | V_{IH} | — | 1.8 | — | — | 2.8 | — | V | |

DC Characteristics-2 ($T_a = 0$ to $+60^\circ\text{C}$, $V_{CC} = 5.0\text{ V} \pm 10\%$)

| Parameter | Symbol | 128MB/ 256MB | | 512MB/ 1GB | | Unit | Test conditions |
|--------------------------------------|----------------------------------|---|-----|---|-----|------|---|
| | | Typ | Max | Typ | Max | | |
| Sleep/ standby current | I_{SP1} | 1.0 | 1.5 | 1.0 | 1.5 | mA | CMOS level (control signal = $V_{CC} - 0.2\text{ V}$) (In Memory card mode and I/O card mode) |
| Sector read current | I_{CCR} (RMS)* ¹ | 40 | 100 | 45 | 100 | mA | CMOS level (control signal = $V_{CC} - 0.2\text{ V}$) during sector read transfer |
| Sector write current | I_{CCW} (RMS)* ¹ | 50 | 100 | 55 | 100 | mA | CMOS level (control signal = $V_{CC} - 0.2\text{ V}$) during sector write transfer |
| Read/Write current peak (Peak) | I_{CC} | 120mA/ 50 μs * ² | — | 120mA/ 50 μs * ² | — | — | CMOS level (control signal = $V_{CC} - 0.2\text{ V}$) |

Note: 1. Average value of the RMS operation current at the time of 128 sector transfer.
2. Reference value.

DC Characteristics-3 ($T_a = 0$ to $+60^\circ\text{C}$, $V_{CC} = 3.3\text{ V} \pm 5\%$)

| Parameter | Symbol | 128MB/ 256MB | | 512MB / 1GB | | Unit | Test conditions |
|--------------------------------------|----------------------------------|---|-----|---|-----|------|---|
| | | Typ | Max | Typ | Max | | |
| Sleep/ standby current | I_{SP1} | 1.0 | 1.5 | 1.0 | 1.5 | mA | CMOS level (control signal = $V_{CC} - 0.2\text{ V}$) (In Memory card mode and I/O card mode) |
| Sector read current | I_{CCR} (RMS)* ¹ | 40 | 75 | 45 | 75 | mA | CMOS level (control signal = $V_{CC} - 0.2\text{ V}$) during sector read transfer |
| Sector write current | I_{CCW} (RMS)* ¹ | 50 | 75 | 55 | 75 | mA | CMOS level (control signal = $V_{CC} - 0.2\text{ V}$) during sector write transfer |
| Read/Write current peak (Peak) | I_{CC} | 120mA/ 50 μs * ² | — | 120mA/ 50 μs * ² | — | — | CMOS level (control signal = $V_{CC} - 0.2\text{ V}$) |

Note: 1. Average value of the RMS operation current at the time of 128 sector transfer.
2. Reference value.

AC Characteristics ($T_a = 0$ to $+60^\circ\text{C}$, $V_{cc} = 5.0\text{ V} \pm 10\%$, $3.3\text{ V} \pm 5\%$)

Attribute Memory Read AC Characteristics

| Parameter | Symbol | 250 ns | | | Unit |
|---------------------------|----------|--------|-----|-----|------|
| | | Min | Typ | Max | |
| Read cycle time | tCR | 250 | — | — | ns |
| Address access time | ta(A) | — | — | 250 | ns |
| -CE access time | ta(CE) | — | — | 250 | ns |
| -OE access time | ta(OE) | — | — | 125 | ns |
| Output disable time (-CE) | tdis(CE) | — | — | 100 | ns |
| Output disable time (-OE) | tdis(OE) | — | — | 100 | ns |
| Output enable time (-CE) | ten(CE) | 5 | — | — | ns |
| Output enable time (-OE) | ten(OE) | 5 | — | — | ns |
| Data valid time (A) | tv(A) | 0 | — | — | ns |
| Address setup time | tsu(A) | 30 | — | — | ns |
| Address hold time | th(A) | 20 | — | — | ns |
| -CE setup time | tsu(CE) | 0 | — | — | ns |
| -CE hold time | th(CE) | 20 | — | — | ns |

Attribute Memory Read Timing

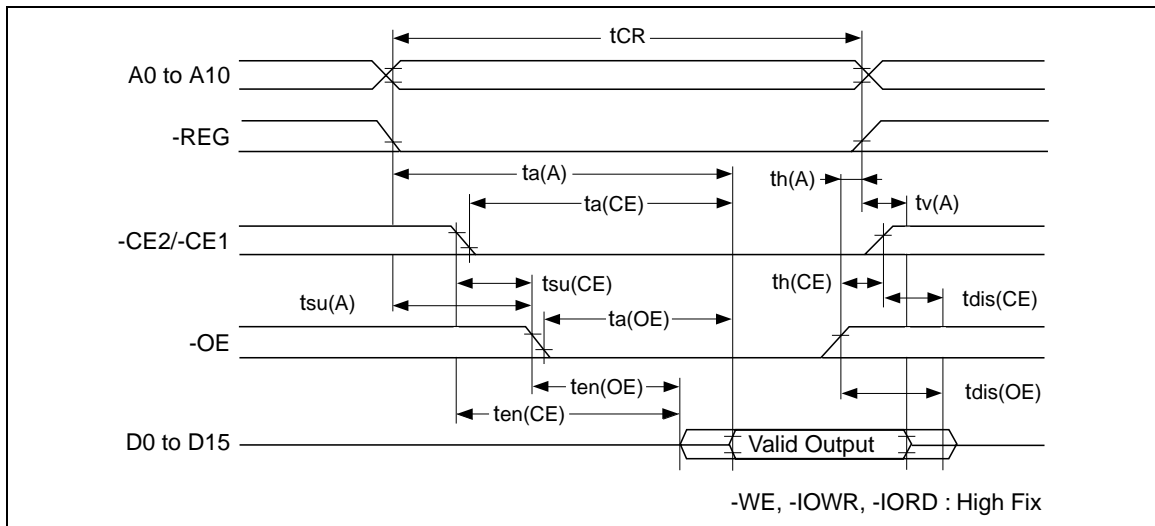

Attribute Memory Write AC Characteristics

| Parameter | Symbol | 250 ns | | | Unit |
|--------------------------------|-------------|--------|-----|-----|------|
| | | Min | Typ | Max | |
| Write cycle time | tCW | 250 | — | — | ns |
| Write pulse time | tw(WE) | 150 | — | — | ns |
| Address setup time | tsu(A) | 30 | — | — | ns |
| Address setup time (-WE) | tsu(A-WEH) | 180 | — | — | ns |
| -CE setup time (-WE) | tsu(CE-WEH) | 180 | — | — | ns |
| Data setup time (-WE) | tsu(D-WEH) | 80 | — | — | ns |
| Data hold time | th(D) | 30 | — | — | ns |
| Write recover time | trec(WE) | 30 | — | — | ns |
| Output disable time (-WE) | tdis(WE) | — | — | 100 | ns |
| Output disable time (-OE) | tdis(OE) | — | — | 100 | ns |
| Output enable time (-WE) | ten(WE) | 5 | — | — | ns |
| Output enable time (-OE) | ten(OE) | 5 | — | — | ns |
| Output enable setup time (-WE) | tsu(OE-WE) | 10 | — | — | ns |
| Output enable hold time (-WE) | th(OE-WE) | 10 | — | — | ns |
| -CE setup time | tsu(CE) | 0 | — | — | ns |
| -CE hold time | th(CE) | 20 | — | — | ns |

Attribute Memory Write Timing

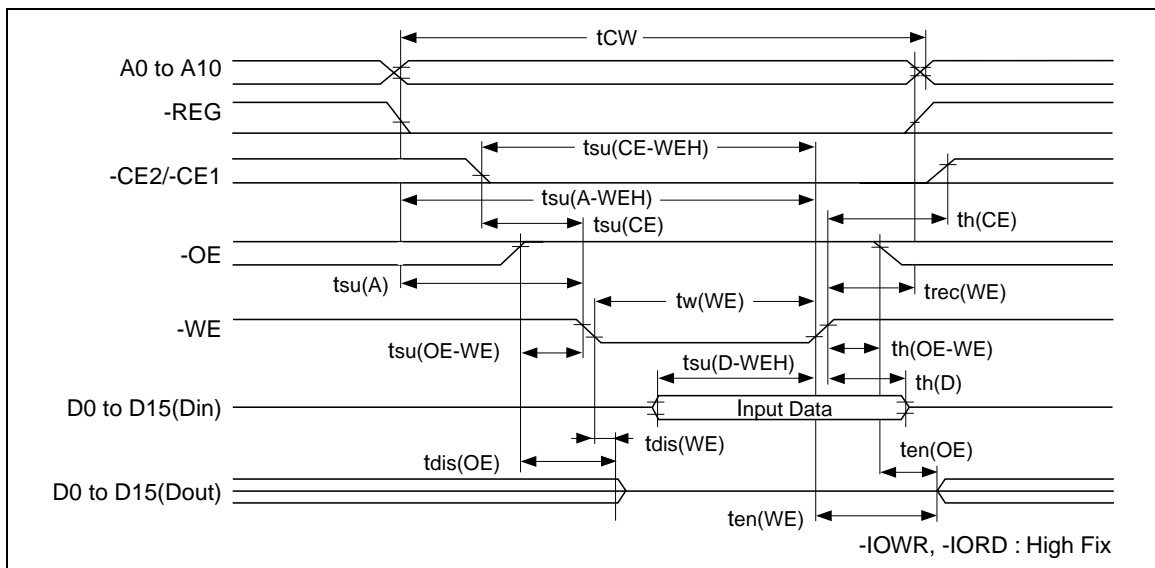

I/O Access Read AC Characteristics

| Parameter | Symbol | Min | Typ | Max | Unit |
|------------------------------------|-----------------|-----|-----|-----|------|
| Data delay after -IORD | td(IORD) | — | — | 100 | ns |
| Data hold following -IORD | th(IORD) | 0 | — | — | ns |
| -IORD pulse width | tw(IORD) | 165 | — | — | ns |
| Address setup before -IORD | tsuA(IORD) | 70 | — | — | ns |
| Address hold following -IORD | thA(IORD) | 20 | — | — | ns |
| -CE setup before -IORD | tsuCE(IORD) | 5 | — | — | ns |
| -CE hold following -IORD | thCE(IORD) | 20 | — | — | ns |
| -REG setup before -IORD | tsuREG(IORD) | 5 | — | — | ns |
| -REG hold following -IORD | thREG(IORD) | 0 | — | — | ns |
| -INPACK delay falling from -IORD | tdfINPACK(IORD) | 0 | — | 45 | ns |
| -INPACK delay rising from -IORD | tdrINPACK(IORD) | — | — | 45 | ns |
| -IOIS16 delay falling from address | tdfIOIS16(ADR) | — | — | 35 | ns |
| -IOIS16 delay rising from address | tdrIOIS16(ADR) | — | — | 35 | ns |

I/O Access Read Timing

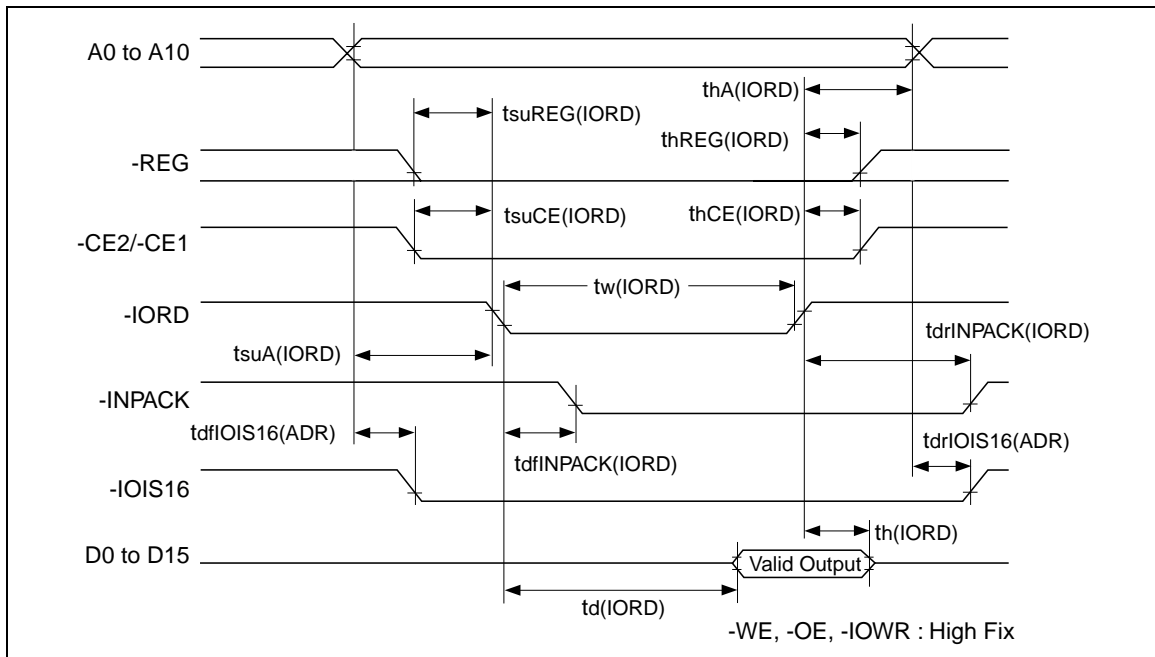

HB28J1000CCC/HB28J512CCC/HB28J256CCC/HB28J128CCC

I/O Access Write AC Characteristics

| Parameter | Symbol | Min | Typ | Max | Unit |
|------------------------------------|----------------|-----|-----|-----|------|
| Data setup before -IOWR | tsu(IOWR) | 60 | — | — | ns |
| Data hold following -IOWR | th(IOWR) | 30 | — | — | ns |
| -IOWR pulse width | tw(IOWR) | 165 | — | — | ns |
| Address setup before -IOWR | tsuA(IOWR) | 70 | — | — | ns |
| Address hold following -IOWR | thA(IOWR) | 20 | — | — | ns |
| -CE setup before -IOWR | tsuCE(IOWR) | 5 | — | — | ns |
| -CE hold following -IOWR | thCE(IOWR) | 20 | — | — | ns |
| -REG setup before -IOWR | tsuREG(IOWR) | 5 | — | — | ns |
| -REG hold following -IOWR | thREG(IOWR) | 0 | — | — | ns |
| -IOIS16 delay falling from address | tdfIOIS16(ADR) | — | — | 35 | ns |
| -IOIS16 delay rising from address | tdrIOIS16(ADR) | — | — | 35 | ns |

I/O Access Write Timing

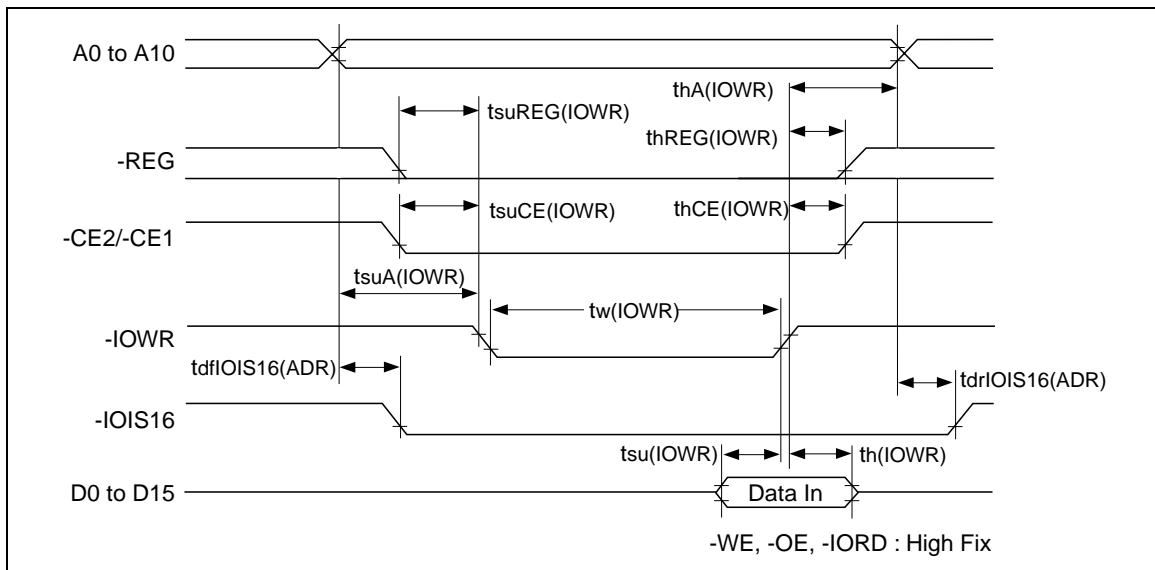

Common Memory Access Read AC Characteristics

| Parameter | Symbol | Min | Typ | Max | Unit |
|---------------------------|----------|-----|-----|-----|------|
| -CE access time | ta(OE) | — | — | 125 | ns |
| Output disable time (-OE) | tdis(OE) | — | — | 100 | ns |
| Address setup time | tsu(A) | 30 | — | — | ns |
| Address hold time | th(A) | 20 | — | — | ns |
| -CE setup time | tsu(CE) | 0 | — | — | ns |
| -CE hold time | th(CE) | 20 | — | — | ns |

Common Access Read Timing

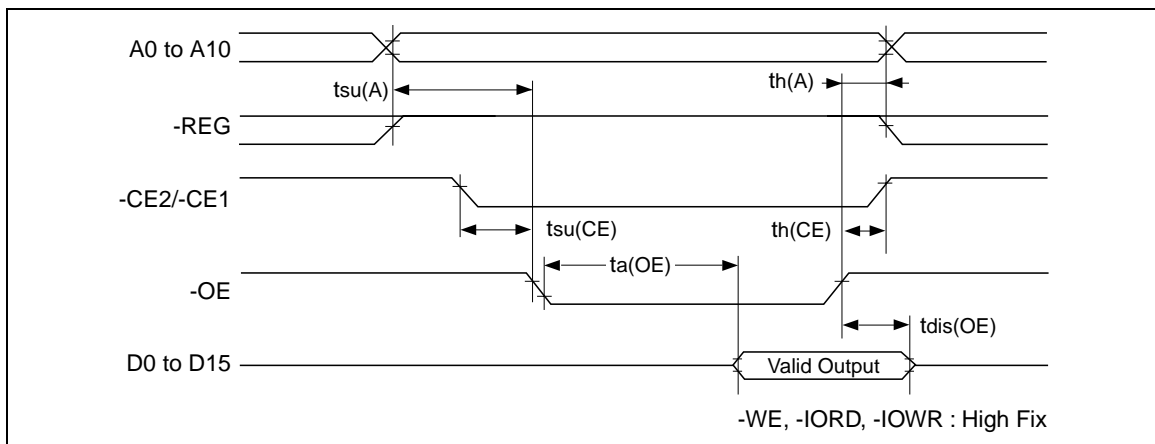

Common Memory Access Write AC characteristics

| Parameter | Symbol | Min | Typ | Max | Unit |
|------------------------|------------|-----|-----|-----|------|
| Data setup time (-WE) | tsu(D-WEH) | 80 | — | — | ns |
| Data hold time | th(D) | 30 | — | — | ns |
| Write pulse time | tw(WE) | 150 | — | — | ns |
| Address setup time | tsu(A) | 30 | — | — | ns |
| -CE setup time | tsu(CE) | 0 | — | — | ns |
| Write recover time | trec(WE) | 30 | — | — | ns |
| -CE hold following -WE | th(CE) | 20 | — | — | ns |

Common Access Write Timing

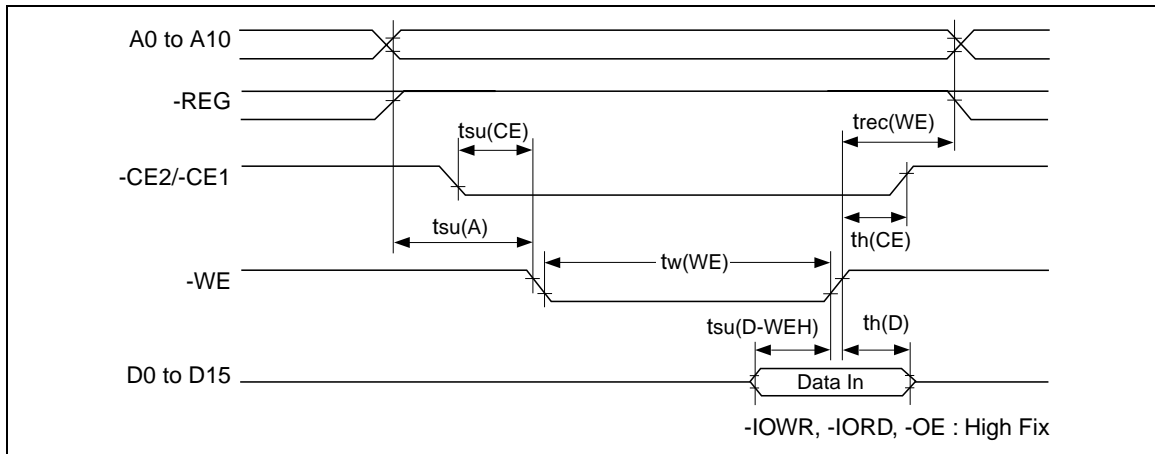

True IDE Mode Access Read/Write AC Characteristics

Register transfer AC Characteristics

| Parameter | | Symbol | Mode0 | Mode1 | Mode2 | Mode3 | Mode4 | Unit |
|------------------------------------|-------|----------|-------|-------|-------|-------|-------|------|
| Cycle time | (min) | t_0 | 600 | 383 | 330 | 180 | 120 | ns |
| Address valid to -IORD/-IOWR setup | (min) | t_1 | 70 | 50 | 30 | 30 | 25 | ns |
| -IORD/-IOWR register setup (8-bit) | (min) | t_2 | 290 | 290 | 290 | 80 | 70 | ns |
| -IORD/-IOWR recovery time | (min) | t_{2i} | — | — | — | 70 | 25 | ns |
| -IOWR data setup | (min) | t_3 | 60 | 45 | 30 | 30 | 20 | ns |
| -IOWR data hold | (min) | t_4 | 30 | 20 | 15 | 10 | 10 | ns |
| -IORD data setup | (min) | t_5 | 50 | 35 | 20 | 20 | 20 | ns |
| -IORD data hold | (min) | t_6 | 5 | 5 | 5 | 5 | 5 | ns |
| -IORD data tristate | (max) | t_{6z} | 30 | 30 | 30 | 30 | 30 | ns |
| Address valid to -IOCS16 assertion | (max) | t_7 | 90 | 50 | 40 | n/a | n/a | ns |
| Address valid to -IOCS16 released | (max) | t_8 | 60 | 45 | 30 | n/a | n/a | ns |
| -IORD/-IOWR to address valid hold | | t_9 | 20 | 15 | 10 | 10 | 10 | ns |

Data transfer AC Characteristics

| Parameter | | Symbol | Mode0 | Mode1 | Mode2 | Mode3 | Mode4 | Unit |
|------------------------------------|-------|----------|-------|-------|-------|-------|-------|------|
| Cycle time | (min) | t_0 | 600 | 383 | 240 | 180 | 120 | ns |
| Address valid to -IORD/-IOWR setup | (min) | t_1 | 70 | 50 | 30 | 30 | 25 | ns |
| -IORD/-IOWR register setup (8-bit) | (min) | t_2 | 165 | 125 | 100 | 80 | 70 | ns |
| -IORD/-IOWR recovery time | (min) | t_{2i} | — | — | — | 70 | 25 | ns |
| -IOWR data setup | (min) | t_3 | 60 | 45 | 30 | 30 | 20 | ns |
| -IOWR data hold | (min) | t_4 | 30 | 20 | 15 | 10 | 10 | ns |
| -IORD data setup | (min) | t_5 | 50 | 35 | 20 | 20 | 20 | ns |
| -IORD data hold | (min) | t_6 | 5 | 5 | 5 | 5 | 5 | ns |
| -IORD data tristate | (max) | t_{6z} | 30 | 30 | 30 | 30 | 30 | ns |
| Address valid to -IOCS16 assertion | (max) | t_7 | 90 | 50 | 40 | n/a | n/a | ns |
| Address valid to -IOCS16 released | (max) | t_8 | 60 | 45 | 30 | n/a | n/a | ns |
| -IORD/-IOWR to address valid hold | | t_9 | 20 | 15 | 10 | 10 | 10 | ns |

True IDE Mode Access Read/Write Timing

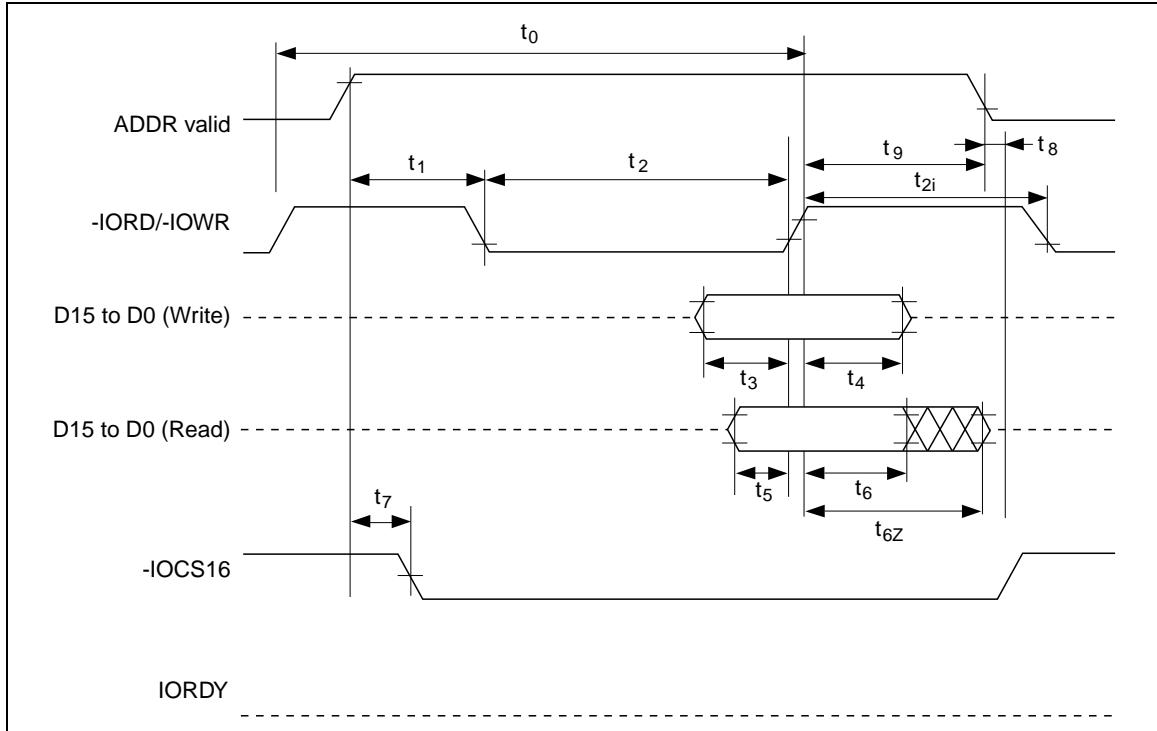

HB28J1000CCC/HB28J512CCC/HB28J256CCC/HB28J128CCC

Reset Characteristics (only Memory Card Mode or I/O Card Mode)

Hard Reset Characteristics

| Parameter | Symbol | Min | Typ | Max | Unit | Test conditions | Note |
|-----------------------|---------------|-----|-----|-----|------|-----------------|------|
| Reset setup time | tsu(RESET) | 20 | — | — | ms | | |
| -CE recover time | trec(VCC) | 1 | — | — | μs | | |
| VCC rising up time | tpr | 0.1 | — | 100 | ms | | |
| VCC falling down time | tpf | 3 | — | 300 | ms | | |
| Reset pulse width | tw(RESET) | 10 | — | — | μs | | |
| | th(Hi-ZRESET) | 1 | — | — | ms | | |
| | ts(Hi-ZRESET) | 0 | — | — | ms | | 1 |

Note: 1. As for this specification, it is fitted activity state when change. When reset signal is non-activity state and a card is ready state, can shift to power supply cutoff sequence instantly.

Hard Reset Timing

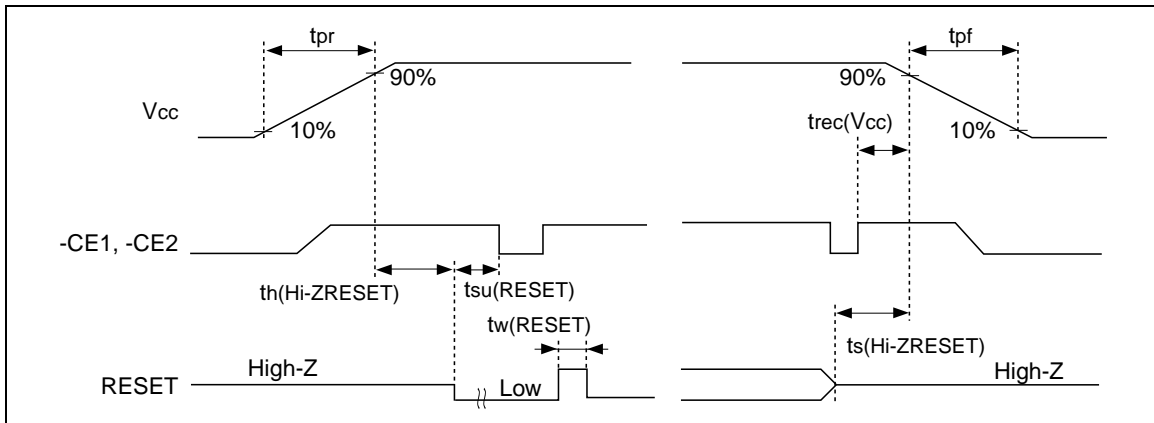

Power on Reset Characteristics

All card status is reset automatically without Hard reset when V_{cc} voltage goes over about 2.3 V.

| Parameter | Symbol | Min | Typ | Max | Unit | Test conditions |
|--------------------|----------|-----|-----|-----|------|-----------------|
| -CE setup time | tsu(VCC) | 20 | — | — | ms | |
| VCC rising up time | tpr | 0.1 | — | 100 | ms | |

Power on Reset Timing

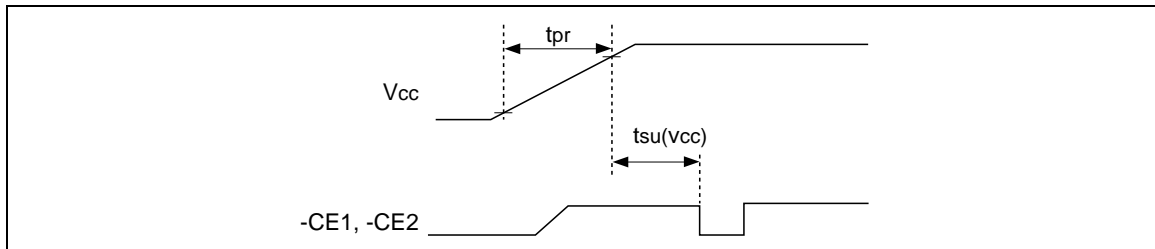

Attention for Card Use

- In the reset or power off, all register informations are cleared.
- All card status is cleared automatically when V_{cc} voltage turns below about 2.5V.
- Notice that the card insertion/removal should not be executed while host is active, if the card is used in True IDE mode.
- After the card hard reset, soft reset, or power on reset, ATA reset, command applied the card cannot access during +RDY/-BSY pin is “low” level. Flash card can’t be operated in this case.
- Card removal or power off should not be done during internal operations. When the removal or power off occurs during internal operation, there is a possibility that data are lost.
- Before the card insertion V_{cc} cannot be supplied to the card. After confirmation that -CD1, -CD2 pins are inserted, supply V_{cc} to the card.
- -OE must be kept at the V_{cc} level during power on reset in memory card mode and I/O card mode. -OE must be kept constantly at the GND level in True IDE mode.
- We recommend that a circuit to detect the level of power supply voltage be added to the host.
- When a read error occurs, rewriting of the sector is recommended. This may avoid the error.
- Because of the delay of internal power circuit, it may occur that any pin level isn't fixed immediately in power on.

Physical Outline

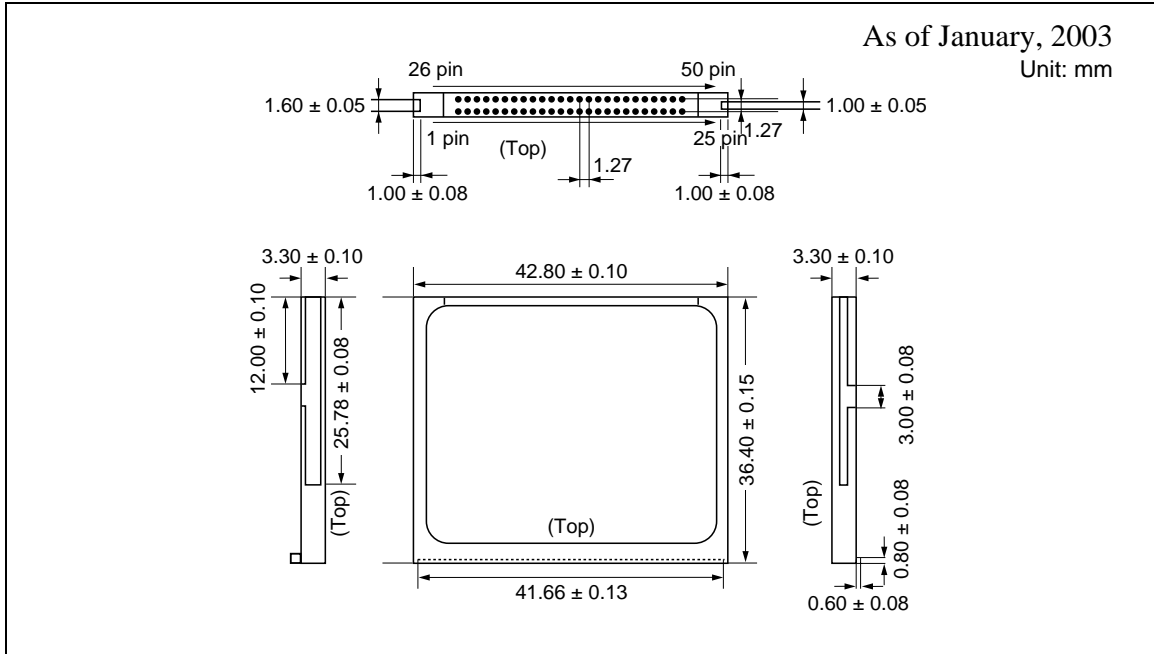

Caution for Handling Cards

- Confirm the direction of insertion before inserting the card.
- Be careful not to damage the connector.
- To avoid damaging the card, never insert it in the wrong direction.
- Do not bend the card; do not drop the card or expose the card to mechanical shock of any other kind.
- Never modify or disassemble the card.
- Do not expose the card to static electricity or electrical noise.
- Make regular backups of the data in the card.

Revision History

HB28J1000CCC/HB28J512CCC/HB28J256CCC/HB28J128CCC\ Data Sheet

| Rev. | Date | Contents of Modification | |
|------|---------------|--------------------------|---|
| | | Page | Description |
| 0.0 | Feb. 10. 2003 | — | Initial issue |
| 1.00 | Dec. 03. 2003 | — | Change format issued by Renesas Technology Corp. |
| | | — | Deletion of Preliminary |
| | | 1 | Description Addition of the description about CFA2.0 |
| | | 1 | Features True IDE mode: addition of the description about PIO mode4 |
| | | 3-4 | Card Pin Assignment Pin No.7,32,43,44: Change of Signal names in True IDE Mode Addition of note 1 |
| | | 6-7 | Card Pin Explanation Pin No.43,44: Change of Signal names and Descriptions in True IDE Mode DMARQ,DMACK to RFU |
| | | 38 | 11. Command register Deletion of Parameter table Deletion of Parameter notes Addition of Parameters Deletion of Y and N |
| | | 40-46 | ATA Command specifications ATA Command Set Deletion of Pin No.31,32 |
| | | 42-44 | Change of Identify Drive Information Word address: 5, 49, 52, 59, 62, 63, 91 to 127, 161 to 255 |
| | | 52-53 | Change of DC Characteristics |
| | | — | AC Characteristics Deletion of Multiword DMA Mode Access AC Characteristics Deletion of Multiword DMA Mode Access Timing |
| | | 63 | Attention for Card Use Addition of the description about the delay of internal power circuit at power on |

Renesas Technology Corp. Sales Strategic Planning Div. Nippon Bldg., 2-6-2, Ohte-machi, Chiyoda-ku, Tokyo 100-0004, Japan

Keep safety first in your circuit designs!

1. Renesas Technology Corp. puts the maximum effort into making semiconductor products better and more reliable, but there is always the possibility that trouble may occur with them. Trouble with semiconductors may lead to personal injury, fire or property damage.
Remember to give due consideration to safety when making your circuit designs, with appropriate measures such as (i) placement of substitutive, auxiliary circuits, (ii) use of nonflammable material or (iii) prevention against any malfunction or mishap.

Notes regarding these materials

1. These materials are intended as a reference to assist our customers in the selection of the Renesas Technology Corp. product best suited to the customer's application; they do not convey any license under any intellectual property rights, or any other rights, belonging to Renesas Technology Corp. or a third party.
 2. Renesas Technology Corp. assumes no responsibility for any damage, or infringement of any third-party's rights, originating in the use of any product data, diagrams, charts, programs, algorithms, or circuit application examples contained in these materials.
 3. All information contained in these materials, including product data, diagrams, charts, programs and algorithms represents information on products at the time of publication of these materials, and are subject to change by Renesas Technology Corp. without notice due to product improvements or other reasons. It is therefore recommended that customers contact Renesas Technology Corp. or an authorized Renesas Technology Corp. product distributor for the latest product information before purchasing a product listed herein.
The information described here may contain technical inaccuracies or typographical errors.
Renesas Technology Corp. assumes no responsibility for any damage, liability, or other loss rising from these inaccuracies or errors.
Please also pay attention to information published by Renesas Technology Corp. by various means, including the Renesas Technology Corp. Semiconductor home page (<http://www.renesas.com>).
 4. When using any or all of the information contained in these materials, including product data, diagrams, charts, programs, and algorithms, please be sure to evaluate all information as a total system before making a final decision on the applicability of the information and products. Renesas Technology Corp. assumes no responsibility for any damage, liability or other loss resulting from the information contained herein.
 5. Renesas Technology Corp. semiconductors are not designed or manufactured for use in a device or system that is used under circumstances in which human life is potentially at stake. Please contact Renesas Technology Corp. or an authorized Renesas Technology Corp. product distributor when considering the use of a product contained herein for any specific purposes, such as apparatus or systems for transportation, vehicular, medical, aerospace, nuclear, or undersea repeater use.
 6. The prior written approval of Renesas Technology Corp. is necessary to reprint or reproduce in whole or in part these materials.
 7. If these products or technologies are subject to the Japanese export control restrictions, they must be exported under a license from the Japanese government and cannot be imported into a country other than the approved destination.
Any diversion or reexport contrary to the export control laws and regulations of Japan and/or the country of destination is prohibited.
 8. Please contact Renesas Technology Corp. for further details on these materials or the products contained therein.
-



RENESAS SALES OFFICES

<http://www.renesas.com>

Renesas Technology America, Inc.
450 Holger Way, San Jose, CA 95134-1368, U.S.A
Tel: <1> (408) 382-7500 Fax: <1> (408) 382-7501

Renesas Technology Europe Limited.
Dukes Meadow, Millboard Road, Bourne End, Buckinghamshire, SL8 5FH, United Kingdom
Tel: <44> (1628) 585 100, Fax: <44> (1628) 585 900

Renesas Technology Europe GmbH
Dornacher Str. 3, D-85622 Feldkirchen, Germany
Tel: <49> (89) 380 70 0, Fax: <49> (89) 929 30 11

Renesas Technology Hong Kong Ltd.
7/F., North Tower, World Finance Centre, Harbour City, Canton Road, Hong Kong
Tel: <852> 2265-6688, Fax: <852> 2375-6836

Renesas Technology Taiwan Co., Ltd.
FL 10, #99, Fu-Hsing N. Rd., Taipei, Taiwan
Tel: <886> (2) 2715-2888, Fax: <886> (2) 2713-2999

Renesas Technology (Shanghai) Co., Ltd.
26/F., Ruijin Building, No.205 Maoming Road (S), Shanghai 200020, China
Tel: <86> (21) 6472-1001, Fax: <86> (21) 6415-2952

Renesas Technology Singapore Pte. Ltd.
1, Harbour Front Avenue, #06-10, Keppel Bay Tower, Singapore 098632
Tel: <65> 6213-0200, Fax: <65> 6278-8001