

To all our customers

---

## **Regarding the change of names mentioned in the document, such as Hitachi Electric and Hitachi XX, to Renesas Technology Corp.**

---

The semiconductor operations of Mitsubishi Electric and Hitachi were transferred to Renesas Technology Corporation on April 1st 2003. These operations include microcomputer, logic, analog and discrete devices, and memory chips other than DRAMs (flash memory, SRAMs etc.) Accordingly, although Hitachi, Hitachi, Ltd., Hitachi Semiconductors, and other Hitachi brand names are mentioned in the document, these names have in fact all been changed to Renesas Technology Corp. Thank you for your understanding. Except for our corporate trademark, logo and corporate statement, no changes whatsoever have been made to the contents of the document, and these changes do not constitute any alteration to the contents of the document itself.

Renesas Technology Home Page: <http://www.renesas.com>

Renesas Technology Corp.  
Customer Support Dept.  
April 1, 2003

## Cautions

Keep safety first in your circuit designs!

1. Renesas Technology Corporation puts the maximum effort into making semiconductor products better and more reliable, but there is always the possibility that trouble may occur with them. Trouble with semiconductors may lead to personal injury, fire or property damage.

Remember to give due consideration to safety when making your circuit designs, with appropriate measures such as (i) placement of substitutive, auxiliary circuits, (ii) use of nonflammable material or (iii) prevention against any malfunction or mishap.

Notes regarding these materials

1. These materials are intended as a reference to assist our customers in the selection of the Renesas Technology Corporation product best suited to the customer's application; they do not convey any license under any intellectual property rights, or any other rights, belonging to Renesas Technology Corporation or a third party.
2. Renesas Technology Corporation assumes no responsibility for any damage, or infringement of any third-party's rights, originating in the use of any product data, diagrams, charts, programs, algorithms, or circuit application examples contained in these materials.
3. All information contained in these materials, including product data, diagrams, charts, programs and algorithms represents information on products at the time of publication of these materials, and are subject to change by Renesas Technology Corporation without notice due to product improvements or other reasons. It is therefore recommended that customers contact Renesas Technology Corporation or an authorized Renesas Technology Corporation product distributor for the latest product information before purchasing a product listed herein.  
The information described here may contain technical inaccuracies or typographical errors. Renesas Technology Corporation assumes no responsibility for any damage, liability, or other loss rising from these inaccuracies or errors.  
Please also pay attention to information published by Renesas Technology Corporation by various means, including the Renesas Technology Corporation Semiconductor home page (<http://www.renesas.com>).
4. When using any or all of the information contained in these materials, including product data, diagrams, charts, programs, and algorithms, please be sure to evaluate all information as a total system before making a final decision on the applicability of the information and products. Renesas Technology Corporation assumes no responsibility for any damage, liability or other loss resulting from the information contained herein.
5. Renesas Technology Corporation semiconductors are not designed or manufactured for use in a device or system that is used under circumstances in which human life is potentially at stake. Please contact Renesas Technology Corporation or an authorized Renesas Technology Corporation product distributor when considering the use of a product contained herein for any specific purposes, such as apparatus or systems for transportation, vehicular, medical, aerospace, nuclear, or undersea repeater use.
6. The prior written approval of Renesas Technology Corporation is necessary to reprint or reproduce in whole or in part these materials.
7. If these products or technologies are subject to the Japanese export control restrictions, they must be exported under a license from the Japanese government and cannot be imported into a country other than the approved destination.  
Any diversion or reexport contrary to the export control laws and regulations of Japan and/or the country of destination is prohibited.
8. Please contact Renesas Technology Corporation for further details on these materials or the products contained therein.

---

# HN58V1001 Series

1M EEPROM (128-kword  $\times$  8-bit)  
Ready/ $\overline{\text{Busy}}$  and  $\overline{\text{RES}}$  function



ADE-203-314G (Z)  
Rev. 7.0  
Oct. 31, 1997

---

## Description

The Hitachi HN58V1001 is an electrically erasable and programmable ROM organized as 131072-word  $\times$  8-bit. It has realized high speed, low power consumption and high reliability by employing advanced MNOS memory technology and CMOS process and circuitry technology. It also has a 128-byte page programming function to make the write operations faster.

## Features

- Single 3 V supply: 2.7 V to 5.5 V
- Access time: 250 ns (max)
- Power dissipation
  - Active: 20 mW/MHz, (typ)
  - Standby: 110  $\mu$ W (max)
- On-chip latches: address, data,  $\overline{\text{CE}}$ ,  $\overline{\text{OE}}$ ,  $\overline{\text{WE}}$
- Automatic byte write: 15 ms (max)
- Automatic page write (128 bytes): 15 ms (max)
- $\overline{\text{Data}}$  polling and  $\text{RDY}/\overline{\text{Busy}}$
- Data protection circuit on power on/off
- Conforms to JEDEC byte-wide standard
- Reliable CMOS with MNOS cell technology
- $10^4$  erase/write cycles (in page mode)
- 10 years data retention
- Software data protection
- Write protection by  $\overline{\text{RES}}$  pin

# HN58V1001 Series

## Ordering Information

Type No.	Access time	Package
HN58V1001P-25	250 ns	600 mil 32-pin plastic DIP (DP-32)
HN58V1001FP-25	250 ns	525 mil 32-pin plastic SOP (FP-32D)
HN58V1001T-25	250 ns	8 × 14 mm 32-pin plastic TSOP (TFP-32DA)

## Pin Arrangement

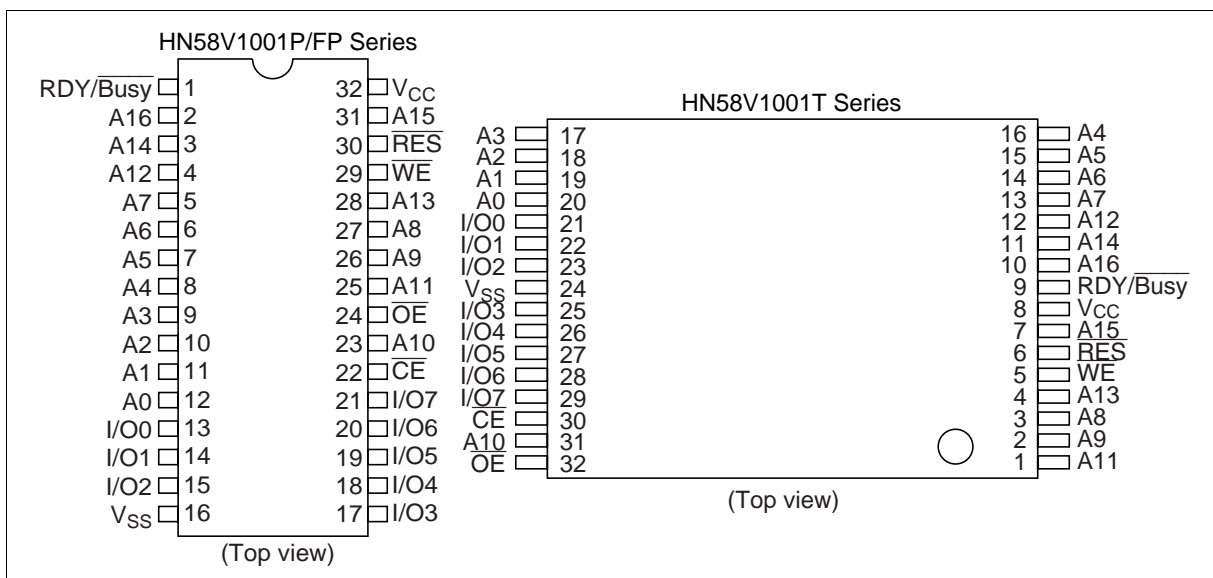

## Pin Description

Pin name	Function
A0 to A16	Address input
I/O0 to I/O7	Data input/output
OE	Output enable
CE	Chip enable
WE	Write enable
V <sub>CC</sub>	Power supply
V <sub>SS</sub>	Ground
RDY/Busy	Ready busy
RES	Reset

**Block Diagram**

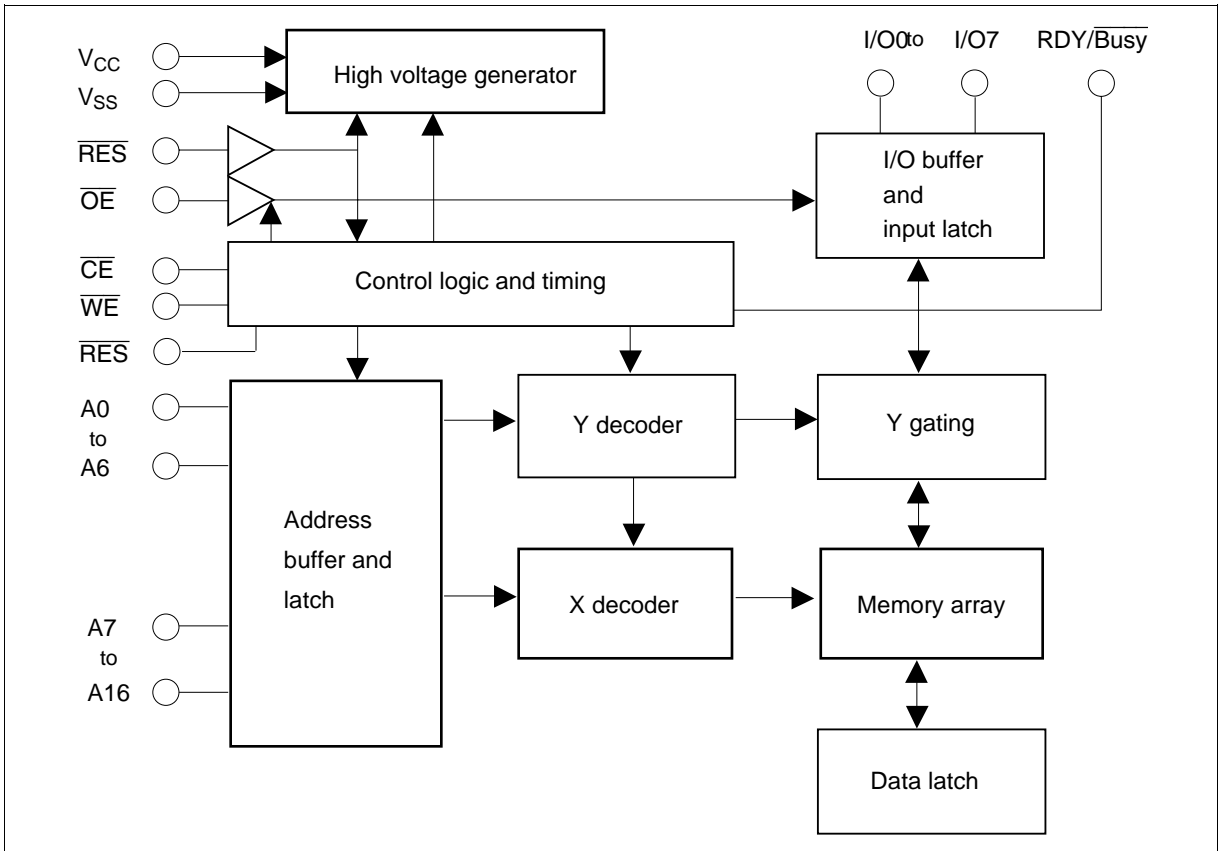

**Operation Table**

Operation	$\overline{CE}$	$\overline{OE}$	$\overline{WE}$	$\overline{RES}$	$\overline{RDY/Busy}$	I/O
Read	$V_{IL}$	$V_{IL}$	$V_{IH}$	$V_H^{*1}$	High-Z	Dout
Standby	$V_{IH}$	$\times^{*2}$	$\times$	$\times$	High-Z	High-Z
Write	$V_{IL}$	$V_{IH}$	$V_{IL}$	$V_H$	High-Z to $V_{OL}$	Din
Deselect	$V_{IL}$	$V_{IH}$	$V_{IH}$	$V_H$	High-Z	High-Z
Write Inhibit	$\times$	$\times$	$V_{IH}$	$\times$	—	—
	$\times$	$V_{IL}$	$\times$	$\times$	—	—
Data Polling	$V_{IL}$	$V_{IL}$	$V_{IH}$	$V_H$	$V_{OL}$	Dout (I/O7)
Program reset	$\times$	$\times$	$\times$	$V_{IL}$	High-Z	High-Z

Notes: 1. Refer to the recommended DC operating conditions.  
 2.  $\times$  : Don't care

## Absolute Maximum Ratings

Parameter	Symbol	Value	Unit
Supply voltage relative to $V_{SS}$	$V_{CC}$	-0.6 to +7.0	V
Input voltage relative to $V_{SS}$	$V_{in}$	-0.5* <sup>1</sup> to +7.0	V
Operating temperature range* <sup>2</sup>	$T_{opr}$	0 to +70	°C
Storage temperature range	$T_{stg}$	-55 to +125	°C

Notes: 1.  $V_{in}$  min = -3.0 V for pulse width  $\leq$  50 ns  
 2. Including electrical characteristics and data retention

## Recommended DC Operating Conditions

Parameter	Symbol	Min	Typ	Max	Unit
Supply voltage	$V_{CC}$	2.7	3.0	5.5	V
	$V_{SS}$	0	0	0	V
Input voltage	$V_{IL}$	-0.3* <sup>1</sup>	—	0.8	V
	$V_{IH}$	1.9* <sup>2</sup>	—	$V_{CC} + 0.3$	V
	$V_H$	$V_{CC} - 0.5$	—	$V_{CC} + 1.0$	V
Operating temperature	$T_{opr}$	0	—	70	°C

Notes: 1.  $V_{IL}$  (min): -1.0 V for pulse width  $\leq$  50 ns  
 2.  $V_{IH}$  (min): 2.2 V for  $V_{CC} = 3.6$  to 5.5 V

## DC Characteristics ( $T_a = 0$ to +70 °C, $V_{CC} = 2.7$ V to 5.5 V)

Parameter	Symbol	Min	Typ	Max	Unit	Test conditions
Input leakage current	$I_{LI}$	—	—	2* <sup>1</sup>	$\mu$ A	$V_{CC} = 3.6$ V, $V_{in} = 3.6$ V
Output leakage current	$I_{LO}$	—	—	2	$\mu$ A	$V_{CC} = 3.6$ V, $V_{out} = 3.6/0.4$ V
Standby $V_{CC}$ current	$I_{CC1}$	—	—	20	$\mu$ A	$\overline{CE} = V_{CC}$
	$I_{CC2}$	—	—	1	mA	$\overline{CE} = V_{IH}$
Operating $V_{CC}$ current	$I_{CC3}$	—	—	6	mA	$I_{out} = 0$ mA, Duty = 100%, Cycle = 1 $\mu$ s at $V_{CC} = 3.3$ V
		—	—	15	mA	$I_{out} = 0$ mA, Duty = 100%, Cycle = 250 ns at $V_{CC} = 3.3$ V
Output low voltage	$V_{OL}$	—	—	0.4	V	$I_{OL} = 2.1$ mA
Output high voltage	$V_{OH}$	$V_{CC} \times 0.8$	—	—	V	$I_{OH} = -400$ $\mu$ A

Notes: 1.  $I_{LI}$  on  $\overline{RES}$ : 100  $\mu$ A (max)

**Capacitance** ( $T_a = 25^\circ\text{C}$ ,  $f = 1\text{ MHz}$ )

Parameter	Symbol	Min	Typ	Max	Unit	Test conditions
Input capacitance*1	Cin	—	—	6	pF	Vin = 0 V
Output capacitance*1	Cout	—	—	12	pF	Vout = 0 V

Note: 1. This parameter is periodically sampled and not 100% tested.

**AC Characteristics** ( $T_a = 0\text{ to }+70\text{ }^\circ\text{C}$ ,  $V_{CC} = 2.7\text{ V to }5.5\text{ V}$ )

**Test Conditions**

- Input pulse levels: 0.4 V to 2.4 V  
0 V to  $V_{CC}$  ( $\overline{\text{RES}}$  pin)
- Input rise and fall time:  $\leq 20\text{ ns}$
- Output load: 1TTL Gate +100 pF
- Reference levels for measuring timing: 0.8 V, 1.8 V

**Read Cycle**

Parameter	Symbol	HN58V1001-25		Unit	Test conditions
		Min	Max		
Address to output delay	$t_{ACC}$	—	250	ns	$\overline{\text{CE}} = \overline{\text{OE}} = V_{IL}$ , $\overline{\text{WE}} = V_{IH}$
$\overline{\text{CE}}$ to output delay	$t_{CE}$	—	250	ns	$\overline{\text{OE}} = V_{IL}$ , $\overline{\text{WE}} = V_{IH}$
$\overline{\text{OE}}$ to output delay	$t_{OE}$	10	120	ns	$\overline{\text{CE}} = V_{IL}$ , $\overline{\text{WE}} = V_{IH}$
Address to output hold	$t_{OH}$	0	—	ns	$\overline{\text{CE}} = \overline{\text{OE}} = V_{IL}$ , $\overline{\text{WE}} = V_{IH}$
$\overline{\text{OE}}$ ( $\overline{\text{CE}}$ ) high to output float*1	$t_{DF}$	0	50	ns	$\overline{\text{CE}} = V_{IL}$ , $\overline{\text{WE}} = V_{IH}$
$\overline{\text{RES}}$ low to output float*1	$t_{DFR}$	0	350	ns	$\overline{\text{CE}} = \overline{\text{OE}} = V_{IL}$ , $\overline{\text{WE}} = V_{IH}$
$\overline{\text{RES}}$ to output delay	$t_{RR}$	0	600	ns	$\overline{\text{CE}} = \overline{\text{OE}} = V_{IL}$ , $\overline{\text{WE}} = V_{IH}$

## Write Cycle

Parameter	Symbol	Min* <sup>2</sup>	Typ	Max	Unit	Test conditions
Address setup time	$t_{AS}$	0	—	—	ns	
Address hold time	$t_{AH}$	150	—	—	ns	
$\overline{CE}$ to write setup time ( $\overline{WE}$ controlled)	$t_{CS}$	0	—	—	ns	
$\overline{CE}$ hold time ( $\overline{WE}$ controlled)	$t_{CH}$	0	—	—	ns	
$\overline{WE}$ to write setup time ( $\overline{CE}$ controlled)	$t_{WS}$	0	—	—	ns	
$\overline{WE}$ hold time ( $\overline{CE}$ controlled)	$t_{WH}$	0	—	—	ns	
$\overline{OE}$ to write setup time	$t_{OES}$	0	—	—	ns	
$\overline{OE}$ hold time	$t_{OEH}$	0	—	—	ns	
Data setup time	$t_{DS}$	100	—	—	ns	
Data hold time	$t_{DH}$	10	—	—	ns	
$\overline{WE}$ pulse width ( $\overline{WE}$ controlled)	$t_{WVP}$	250	—	—	ns	
$\overline{CE}$ pulse width ( $\overline{CE}$ controlled)	$t_{CW}$	250	—	—	ns	
Data latch time	$t_{DL}$	750	—	—	ns	
Byte load cycle	$t_{BLC}$	1.0	—	30	$\mu$ s	
Byte load window	$t_{BL}$	100	—	—	$\mu$ s	
Write cycle time	$t_{WC}$	—	—	15* <sup>3</sup>	ms	
Time to device busy	$t_{DB}$	120	—	—	ns	
Write start time	$t_{DW}$	250* <sup>4</sup>	—	—	ns	
Reset protect time	$t_{RP}$	100	—	—	$\mu$ s	
Reset high time* <sup>5</sup>	$t_{RES}$	1	—	—	$\mu$ s	

Notes: 1.  $t_{DF}$  and  $t_{DFR}$  are defined as the time at which the outputs achieve the open circuit conditions and are no longer driven.

2. Use this device in longer cycle than this value.

3.  $t_{WC}$  must be longer than this value unless polling techniques or  $\overline{RDY}/\overline{Busy}$  are used. This device automatically completes the internal write operation within this value.

4. Next read or write operation can be initiated after  $t_{DW}$  if polling techniques or  $\overline{RDY}/\overline{Busy}$  are used.

5. This parameter is sampled and not 100% tested.

6. A7 to A16 are page addresses and must be same within the page write operation.

7. See AC read characteristics.



## Timing Waveforms

### Read Timing Waveform

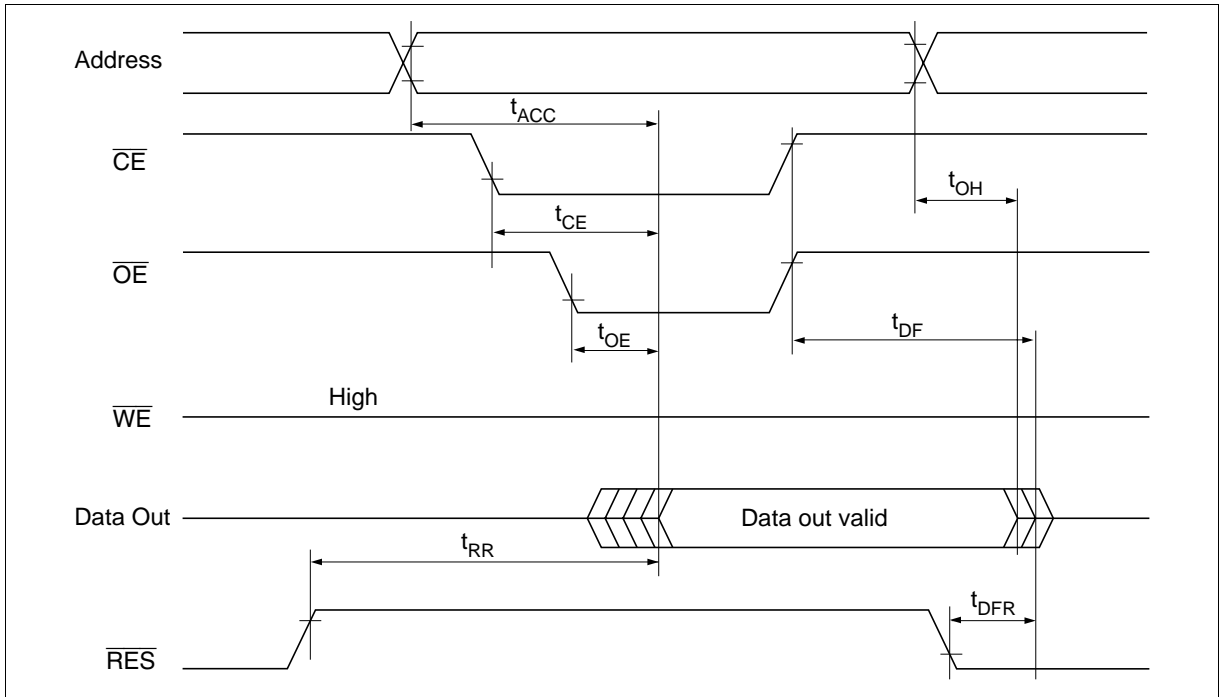

## Byte Write Timing Waveform (1) ( $\overline{WE}$ Controlled)

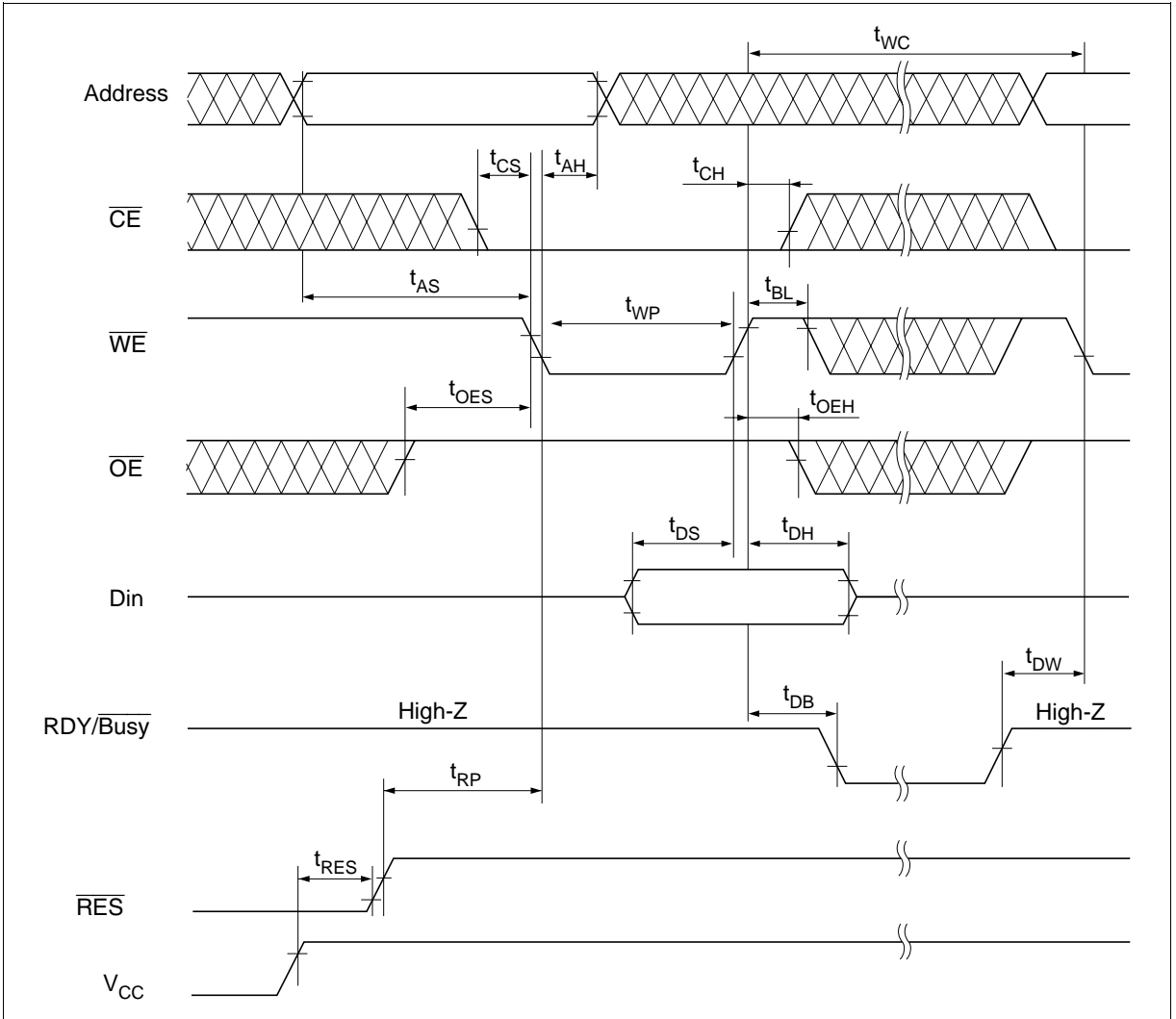

Byte Write Timing Waveform (2) ( $\overline{\text{CE}}$  Controlled)

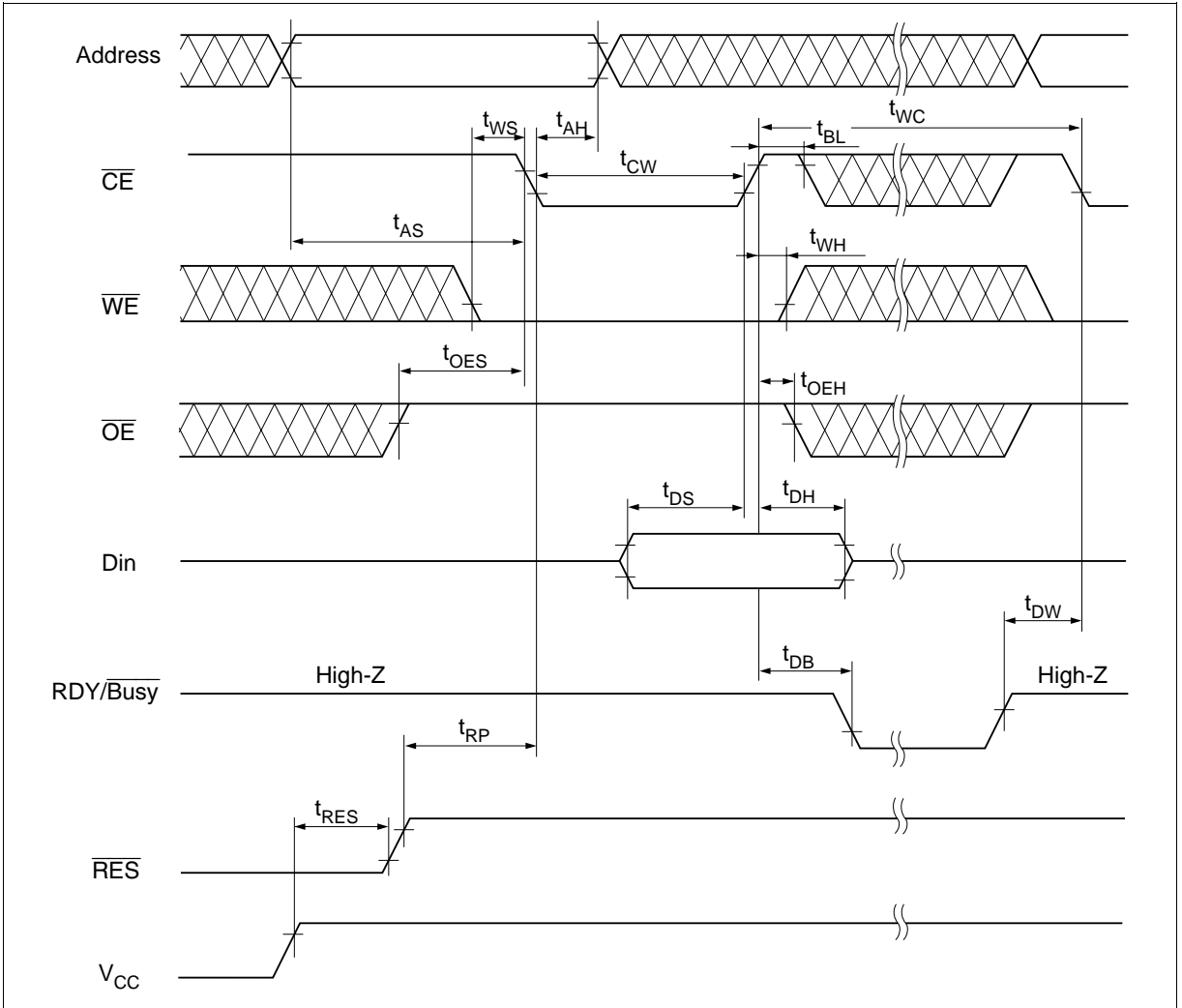

## Page Write Timing Waveform (1) ( $\overline{\text{WE}}$ Controlled)

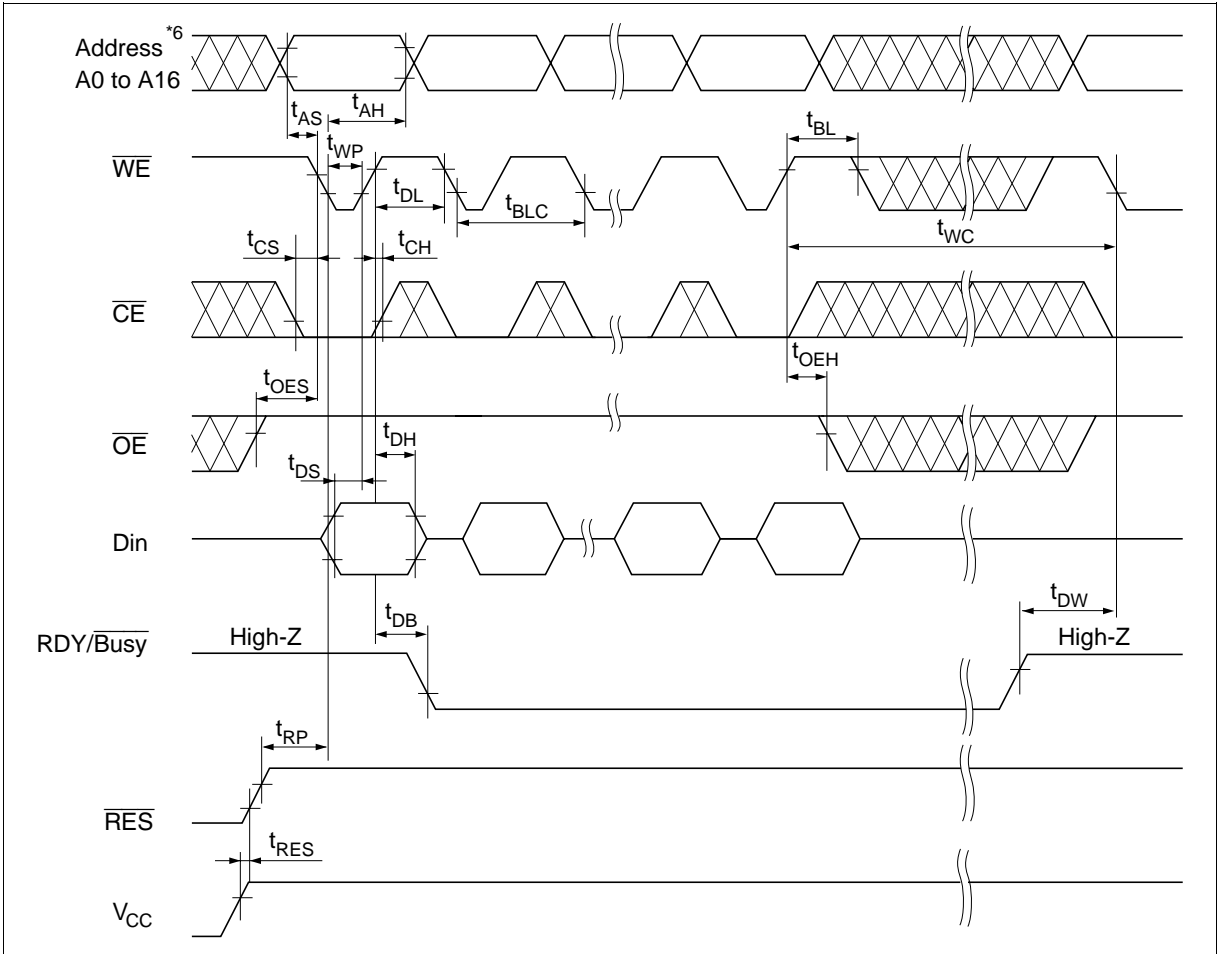

Page Write Timing Waveform (2) ( $\overline{\text{CE}}$  Controlled)

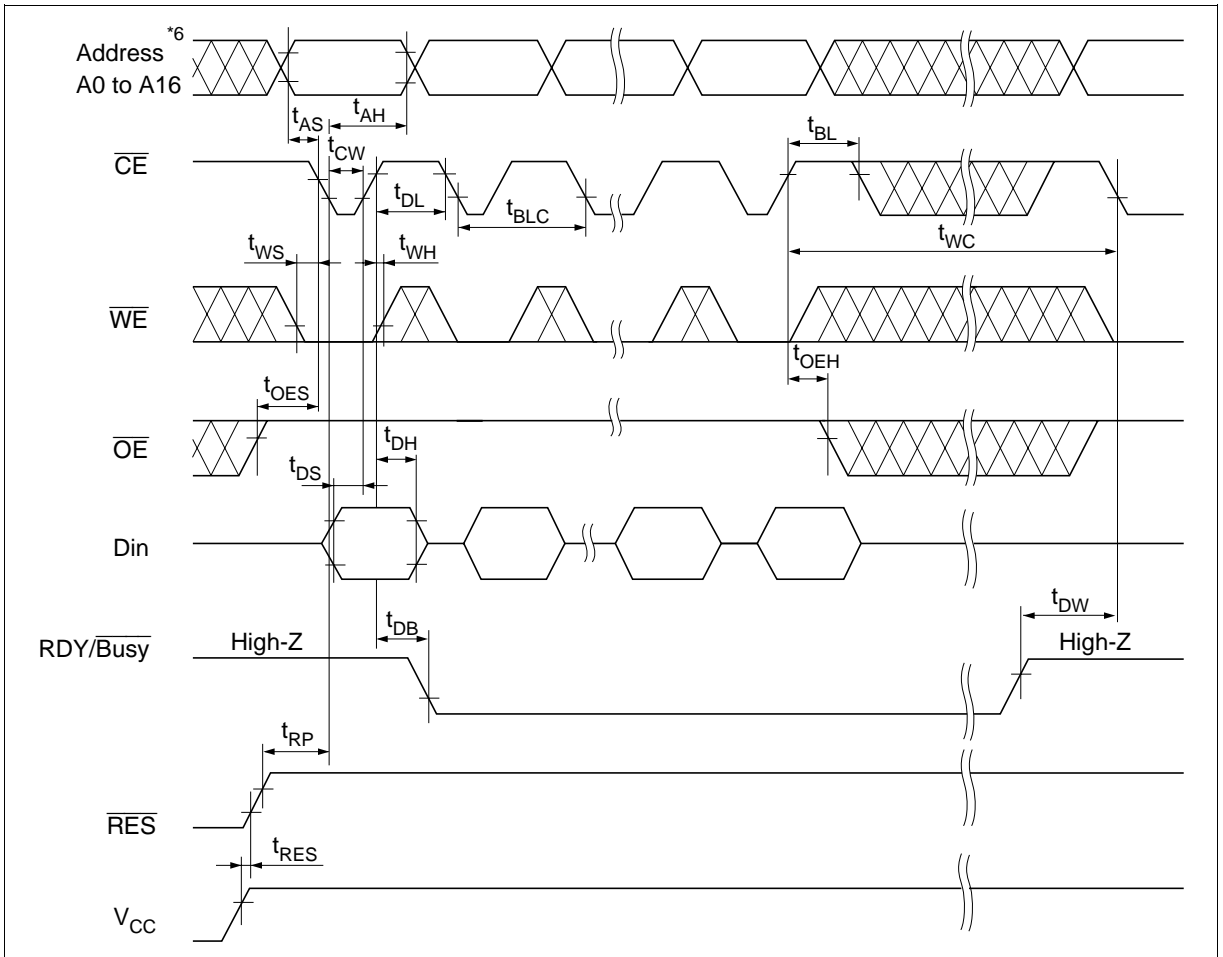

## Data Polling Timing Waveform

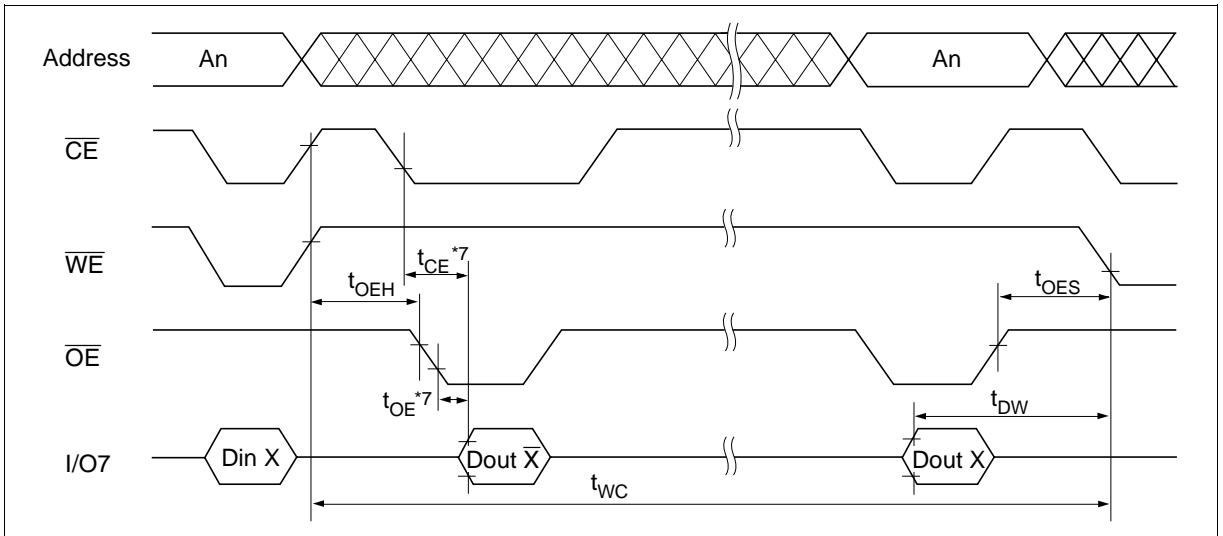

**Toggle bit**

This device provide another function to determine the internal programming cycle. If the EEPROM is set to read mode during the internal programming cycle, I/O6 will charge from “1” to “0” (toggling) for each read. When the internal programming cycle is finished, toggling of I/O6 will stop and the device can be accessible for next read or program.

- Notes:
1. I/O6 beginning state is “1”.
  2. I/O6 ending state will vary.
  3. See AC read characteristics.
  4. Any location can be used, but the address must be fixed.

**Toggle bit Waveform**

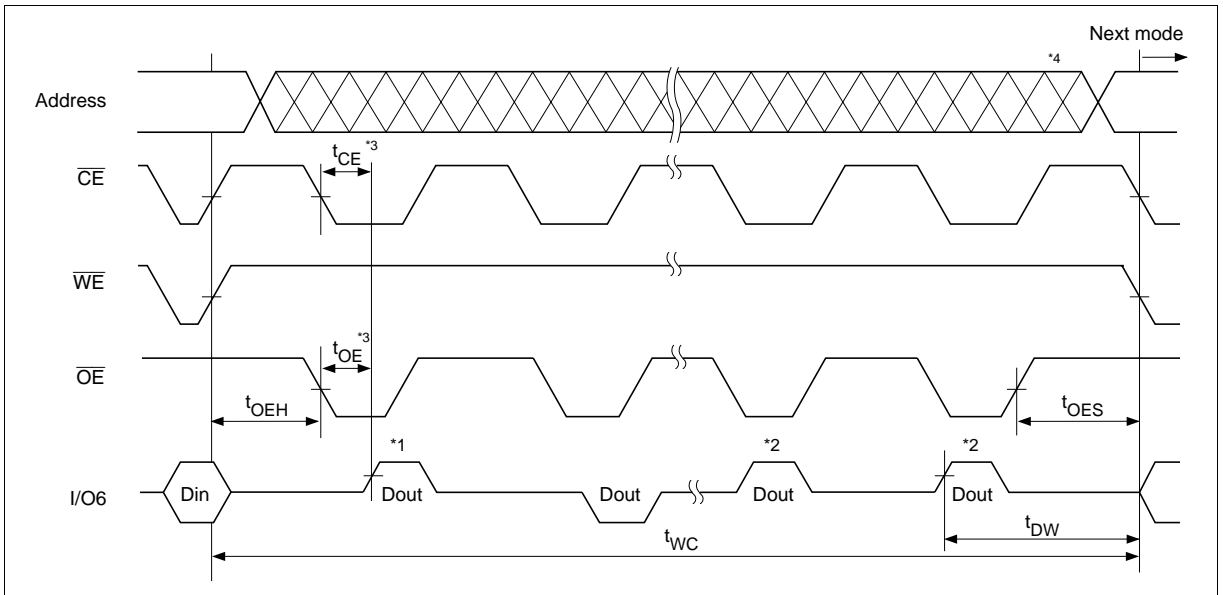

## Software Data Protection Timing Waveform (1) (in protection mode)

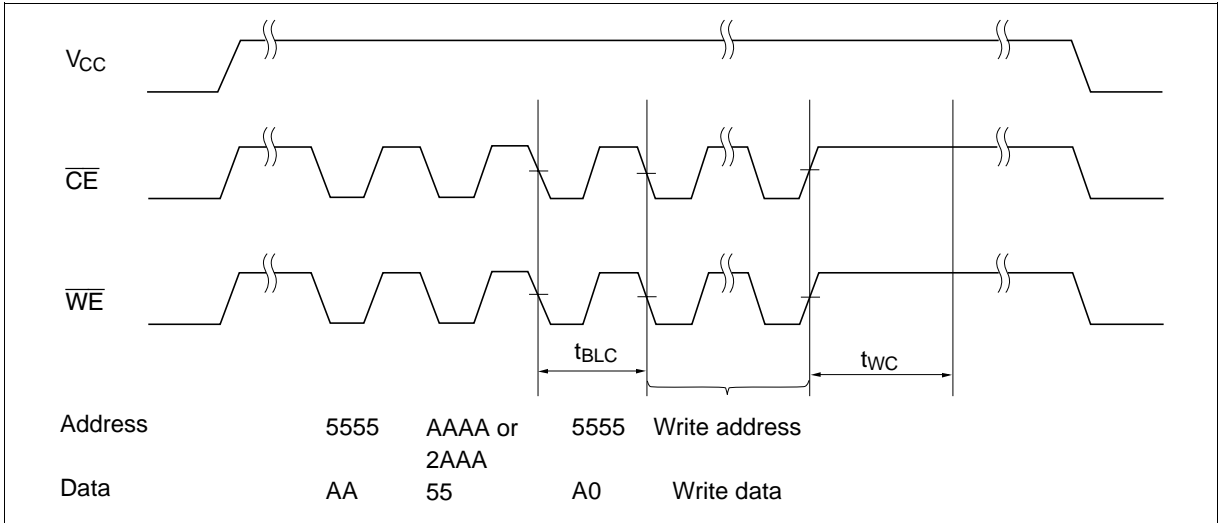

## Software Data Protection Timing Waveform (2) (in non-protection mode)

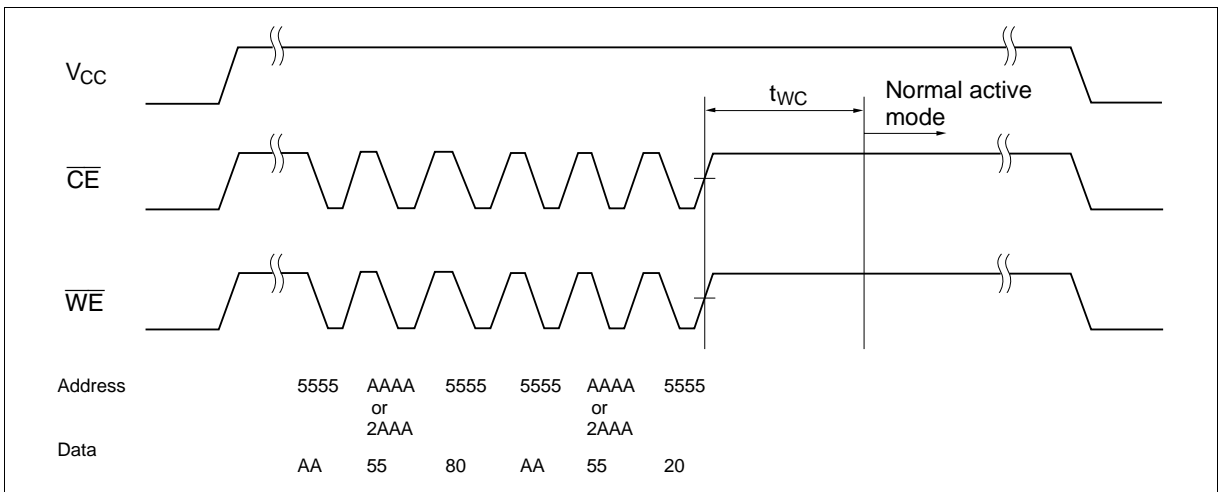



## Functional Description

### Automatic Page Write

Page-mode write feature allows 1 to 128 bytes of data to be written into the EEPROM in a single write cycle. Following the initial byte cycle, an additional 1 to 127 bytes can be written in the same manner. Each additional byte load cycle must be started within 30  $\mu$ s from the preceding falling edge of  $\overline{\text{WE}}$  or  $\overline{\text{CE}}$ . When  $\overline{\text{CE}}$  or  $\overline{\text{WE}}$  is kept high for 100  $\mu$ s after data input, the EEPROM enters write mode automatically and the input data are written into the EEPROM.

### Data Polling

Data polling allows the status of the EEPROM to be determined. If EEPROM is set to read mode during a write cycle, an inversion of the last byte of data to be loaded outputs from I/O7 to indicate that the EEPROM is performing a write operation.

### RDY/Busy Signal

RDY/Busy signal also allows status of the EEPROM to be determined. The RDY/Busy signal has high impedance except in write cycle and is lowered to  $V_{OL}$  after the first write signal. At the end of write cycle, the RDY/Busy signal changes state to high impedance.

### RES Signal

When  $\overline{\text{RES}}$  is low, the EEPROM cannot be read or programmed. Therefore, data can be protected by keeping  $\overline{\text{RES}}$  low when  $V_{CC}$  is switched.  $\overline{\text{RES}}$  should be high during read and programming because it doesn't provide a latch function.

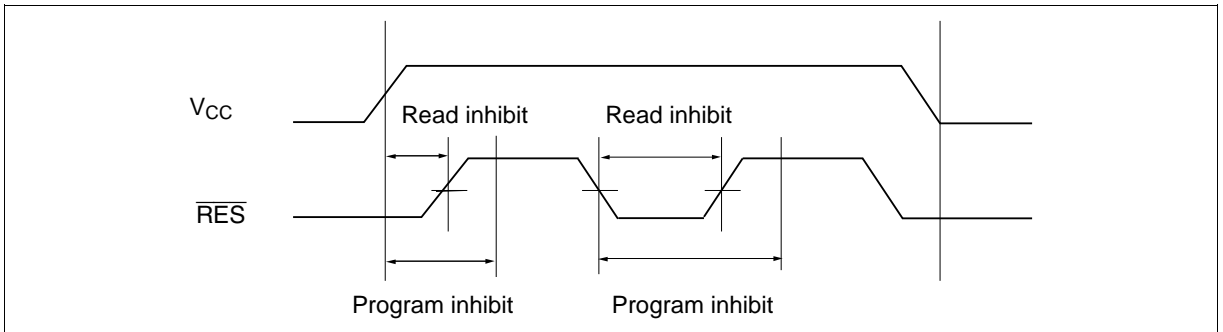

### $\overline{\text{WE}}$ , $\overline{\text{CE}}$ Pin Operation

During a write cycle, addresses are latched by the falling edge of  $\overline{\text{WE}}$  or  $\overline{\text{CE}}$ , and data is latched by the rising edge of  $\overline{\text{WE}}$  or  $\overline{\text{CE}}$ .

## Write/Erase Endurance and Data Retention Time

The endurance is  $10^4$  cycles in case of the page programming and  $10^3$  cycles in case of the byte programming (1% cumulative failure rate). The data retention time is more than 10 years when a device is page-programmed less than  $10^4$  cycles.

## Data Protection

### 1. Data Protection against Noise on Control Pins ( $\overline{\text{CE}}$ , $\overline{\text{OE}}$ , $\overline{\text{WE}}$ ) during Operation

During readout or standby, noise on the control pins may act as a trigger and turn the EEPROM to programming mode by mistake.

To prevent this phenomenon, this device has a noise cancellation function that cuts noise if its width is 20 ns or less in program mode.

Be careful not to allow noise of a width of more than 20 ns on the control pins.

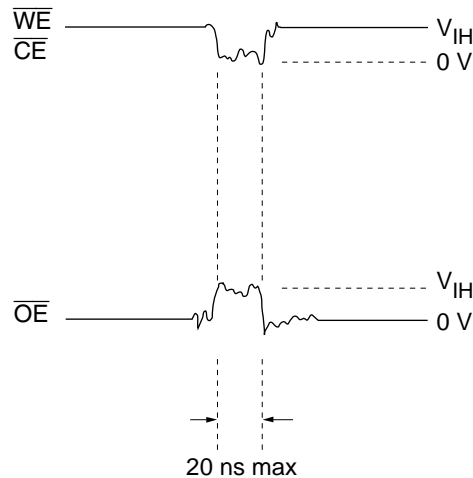

2. Data Protection at  $V_{CC}$  On/Off

When  $V_{CC}$  is turned on or off, noise on the control pins generated by external circuits (CPU, etc) may act as a trigger and turn the EEPROM to program mode by mistake. To prevent this unintentional programming, the EEPROM must be kept in an unprogrammable state while the CPU is in an unstable state.

Note: The EEPROM should be kept in unprogrammable state during  $V_{CC}$  on/off by using CPU RESET signal.

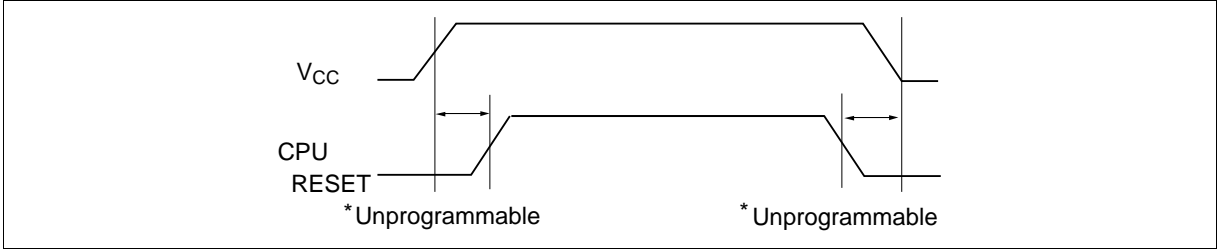

(1) Protection by  $\overline{RES}$

The unprogrammable state can be realized by that the CPU's reset signal inputs directly to the EEPROM's  $\overline{RES}$  pin.  $\overline{RES}$  should be kept  $V_{SS}$  level during  $V_{CC}$  on/off.

The EEPROM brakes off programming operation when  $\overline{RES}$  becomes low, programming operation doesn't finish correctly in case that  $\overline{RES}$  falls low during programming operation.  $\overline{RES}$  should be kept high for 15 ms after the last data input.

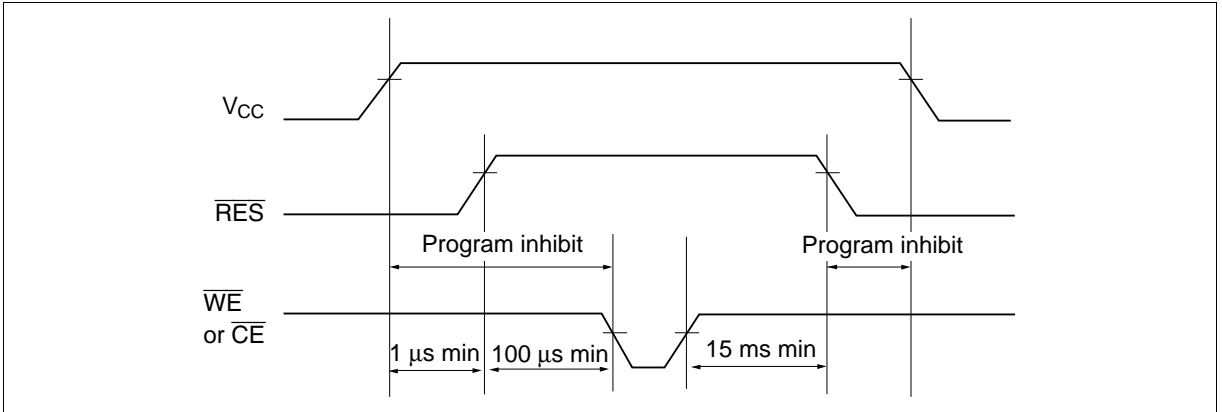

## HN58V1001 Series

### 3. Software data protection

To prevent unintentional programming, this device has the software data protection (SDP) mode. The SDP is enabled by inputting the following 3 bytes code and write data. SDP is not enabled if only the 3 bytes code is input. To program data in the SDP enable mode, 3 bytes code must be input before write data.

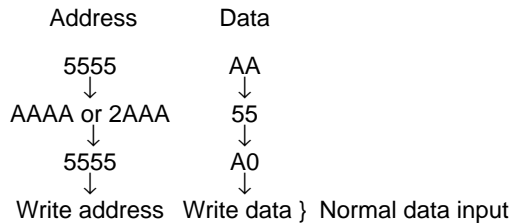

The SDP mode is disabled by inputting the following 6 bytes code. Note that, if data is input in the SDP disable cycle, data can not be written.

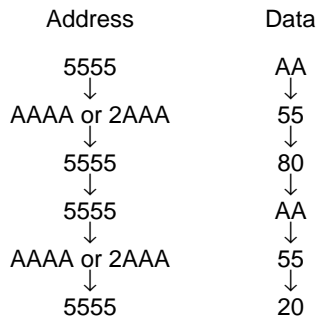

The software data protection is not enabled at the shipment.

Note: There are some differences between Hitachi's and other company's for enable/disable sequence of software data protection. If there are any questions, please contact with Hitachi sales offices.

Package Dimensions

HN58V1001P Series (DP-32)

Unit: mm

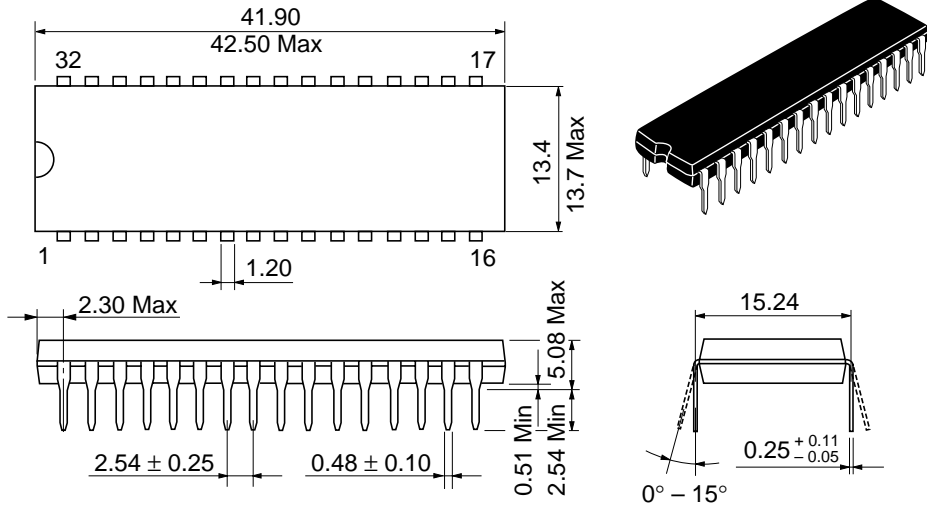

Hitachi Code	DP-32
JEDEC	—
EIAJ	Conforms
Weight (reference value)	5.1 g

# HN58V1001 Series

## Package Dimensions (cont.)

### HN58V1001FP Series (FP-32D)

Unit: mm

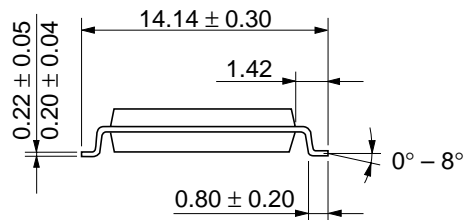
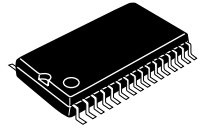
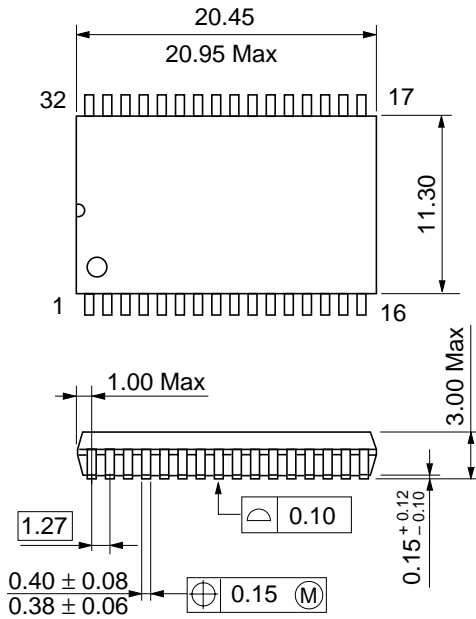

Dimension including the plating thickness  
Base material dimension

Hitachi Code	FP-32D
JEDEC	Conforms
EIAJ	—
Weight (reference value)	1.3 g

Package Dimensions (cont.)

HN58V1001T Series (TFP-32DA)

Unit: mm

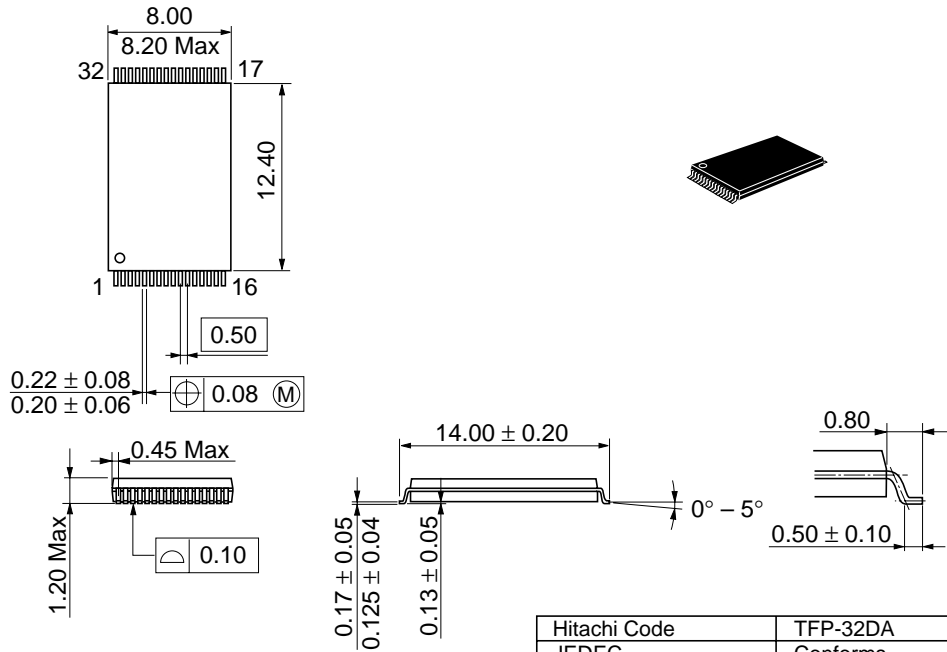

Dimension including the plating thickness  
Base material dimension

Hitachi Code	TFP-32DA
JEDEC	Conforms
EIAJ	Conforms
Weight (reference value)	0.26 g

When using this document, keep the following in mind:

1. This document may, wholly or partially, be subject to change without notice.
2. All rights are reserved: No one is permitted to reproduce or duplicate, in any form, the whole or part of this document without Hitachi's permission.
3. Hitachi will not be held responsible for any damage to the user that may result from accidents or any other reasons during operation of the user's unit according to this document.
4. Circuitry and other examples described herein are meant merely to indicate the characteristics and performance of Hitachi's semiconductor products. Hitachi assumes no responsibility for any intellectual property claims or other problems that may result from applications based on the examples described herein.
5. No license is granted by implication or otherwise under any patents or other rights of any third party or Hitachi, Ltd.
6. **MEDICAL APPLICATIONS:** Hitachi's products are not authorized for use in **MEDICAL APPLICATIONS** without the written consent of the appropriate officer of Hitachi's sales company. Such use includes, but is not limited to, use in life support systems. Buyers of Hitachi's products are requested to notify the relevant Hitachi sales offices when planning to use the products in **MEDICAL APPLICATIONS**.

# HITACHI

## Hitachi, Ltd.

Semiconductor & IC Div.  
Nippon Bldg., 2-6-2, Ohte-machi, Chiyoda-ku, Tokyo 100, Japan  
Tel: Tokyo (03) 3270-2111  
Fax: (03) 3270-5109

### For further information write to:

Hitachi America, Ltd.  
Semiconductor & IC Div.  
2000 Sierra Point Parkway  
Brisbane, CA. 94005-1835  
U S A  
Tel: 415-589-8300  
Fax: 415-583-4207

Hitachi Europe GmbH  
Continental Europe  
Dornacher Straße 3  
D-85622 Feldkirchen  
München  
Tel: 089-9 91 80-0  
Fax: 089-9 29 30-00

Hitachi Europe Ltd.  
Electronic Components Div.  
Northern Europe Headquarters  
Whitebrook Park  
Lower Cookham Road  
Maidenhead  
Berkshire SL6 8YA  
United Kingdom  
Tel: 01628-585000  
Fax: 01628-585160

Hitachi Asia Pte. Ltd.  
16 Collyer Quay #20-00  
Hitachi Tower  
Singapore 049318  
Tel: 535-2100  
Fax: 535-1533

Hitachi Asia (Hong Kong) Ltd.  
Unit 706, North Tower,  
World Finance Centre,  
Harbour City, Canton Road  
Tsim Sha Tsui, Kowloon  
Hong Kong  
Tel: 27359218  
Fax: 27306071

Copyright © Hitachi, Ltd., 1997. All rights reserved. Printed in Japan.