

SWITCHES GAAs

SPDT DC to 4.6 GHz



KSW
*KSWA

MODEL NO.	FREQ. GHz	ABSORPTIVE	REFLECTIVE	INSERTION LOSS, dB								1dB COMP. dBm			IN-OUT ISOLATION, dB				CAPD DATA	CASE STYLE	Connection	PRICE \$		
				FREQUENCY BAND								FREQUENCY BAND			FREQUENCY BAND									
				A		B		C ₁		C ₂		A	B	C	A	B		C						
KSW-2-46	DC-4.6	●	●	0.9	1.1	1.0	1.3	1.3	1.8	2.0	2.8	10	17	27	60	50	50	40	40	28	(see YONI on our website)	XX112	eh	36.95
* KSWA-2-46	DC-4.6	●	●	0.8	1.1	0.9	1.3	1.5	2.6	1.5	2.6	10	17	27	60	45	50	40	30	25		XX112	eh	58.95

A = DC to 200MHz

B = 200MHz to 1000MHz

C = 1000MHz to 4600MHz

C₁ = 1000MHz to 3000MHz

C₂ = 3000MHz to 4600MHz

additional specifications

Model Series	KSW	KSWA	MSW	MSWA	MSWT
Control Voltage	-8/0 for compression spec, -8 to -5/0 for all other specs				
Control Current, mA	2.5 typ. at -8V				
VSWR (:1)	1.3 typ.		DC-1GHz 1.2 typ.	1-2GHz 1.4 typ. 1.45	DC-1GHz .1-.5GHz .5-1GHz 1-2GHz 1.2 1.25 1.4 1.4 1.65 1.8 1.9 1.7
Rise/ Fall time (10% - 90%), ns	2 typ.		2 typ.	3 typ.	2 typ.
Switching time, 50% of Control to 90% RF (Turn-on), ns			4 typ.	5.5 typ.	4 typ.
10% RF (Turn-off), ns			4 typ.	3 typ.	4 typ.
**Video Leakage, mVp-p 0/-5V Control	30 typ.		15 typ.	8 typ.	15 typ.
Temperature, °C operating	-55 to 100		-40 to 85		
storage	-55 to 150		-55 to 100		
MTBF, hrs @100°C case	7X10 ⁶	11X10 ⁶			

NOTES:

- * KSWA model is hermetically sealed.
- ** Video leakage or break through is defined as leakage of TTL switching signal to RF output ports.
- A. Environmental specifications and re-flow soldering information available in General Information Section.
- B. Units are non-hermetic unless otherwise noted. For details on case dimensions & finishes see "Case Styles & Outline Drawings".
- C. Prices and Specifications subject to change without notice.
- 1. Absolute maximum power, voltage and current ratings for KSW, KSWA models:
 - 1a. RF power input, +30 dBm except below 500 MHz +27 dBm;
 - 1b. Control voltage -10 V maximum.
- 2. Absolute maximum power, voltage & current ratings: MSW, MSWA MSWT models:
 - 2a. RF power input, (25°C)

	DC-100	100-500	500-2000	MHz
MSW-2-20: Steady state 0/-8V control,	+23	+27	+31	dBm
As modulator	+11	+17	+21	dBm
MSWA-2-20: Steady state 0/-8V control,	+24	+27	+33	dBm
As modulator	+12	+17	+23	dBm
MSWT-4-20: Steady state 0/-8V control	+24	+27	+33	dBm
modulator application	+12	+17	+23	dBm
 - 2b. Control current, 500µA (Occurs at -9V to -12V typical)
- 3. For reflective switches, KSW, MSW, RSW models, OFF state of RF output is low impedance.

NSN GUIDE

MCL NO.
KSW-2-46
KSWA-2-46

NSN
5985-01-393-7219
5985-01-369-4224

Surface Mount

SPDT DC to 2 GHz

MSW
MSWA
MSWT



MODEL NO.	FREQ. GHz $f_L - f_U$	ABSORPTIVE	REFLECTIVE	INSERTION LOSS, dB								1dB COMP, dBm				IN-OUT ISOLATION, dB								CAPD DATA	CASE STYLE Note B	Connection	PRICE \$ Qty. (10)												
				FREQUENCY BAND A				FREQUENCY BAND B				FREQUENCY BAND C				FREQUENCY BAND D				FREQUENCY BAND A								FREQUENCY BAND B				FREQUENCY BAND C				FREQUENCY BAND D			
				Typ.	Max.	Typ.	Max.	Typ.	Max.	Typ.	Max.	Typ.	Max.	Typ.	Max.	Typ.	Max.	Typ.	Max.	Typ.	Max.	Typ.	Max.					Typ.	Max.	Typ.	Max.	Typ.	Max.	Typ.	Max.	Typ.	Max.	Typ.	Max.
MSW-2-20	DC-2.0	●	●	0.30	0.6	0.4	0.7	0.50	1.0	0.75	1.3	22	23	24	25	55	50	43	36	34	28	24	20	(see YONI on our website)	XX211	es	2.45												
MSWA-2-20	DC-2.0			0.65	0.9	0.9	1.2	0.95	1.3	1.20	1.5	20	24	27	29	60	50	45	37	40	32	30	25	XX211	es	2.45													

TRANSFER DC to 2 GHz Low Video Leakage

Model	FREQ. GHz	path	INSERTION LOSS, dB								ISOLATION, dB								CAPD DATA	CASE STYLE	Connection	PRICE \$				
			A	B	C	D	A	B	C	D	A	B	C	D	A	B	C	D								
MSWT-4-20	DC-2.0	Tx-J1/J2	0.9	1.2	1.1	1.5	1.25	1.8	1.45	2.2	18	25	28	29	51	44	34	27	26	21	19	15	(see YONI on our website)	XX211	eu	3.45
		J1/J2-Rx Tx-Rx	1.1	1.4	1.3	1.7	1.5	2.0	1.6	2.2	16	18	20	22	53	41	36	34	27	24	21	17				

A=DC to 100MHz B=100MHz to 500MHz C=500MHz to 1000MHz D=1000MHz to 2000MHz

control logic

Model	Control Ports				RF outputs	
	1	2	3	4	1	2
KSW, KSWA	-v	0	—	—	On	Off
MSW, MSWA	0	-v	—	—	Off	On
MSWT					"On" Path (other paths are "OFF")	
	0	-v	-v	-v	Tx-J2	
	-v	0	-v	-v	Tx-J1	
	-v	-v	0	-v	Rx-J1	
	-v	-v	-v	0	Rx-J2	
	0	-v	0	-v	Tx-J2 & Rx-J1	
-v	0	-v	0	Tx-J1 & Rx-J2		

pin connections

see case style outline drawings

PORT	eh	ek	es	et	PORT	eu
RF IN	2	1	2	1	Tx	2
RF OUT 1	5	5	8	6	Rx	6
RF OUT 2	8	—	5	3	J1	4
+5V	—	—	—	—	J2	8
CONTROL 1	3	2	3	5	CONTROL 1	1
CONTROL 2	1	3	1	4	CONTROL 2	3
GND EXT.	4,6,7	4,6,7,8	4,6,7	2,7,8	CONTROL 3	5
					CONTROL 4	7

Application Note for Model MSWT-4-20 Transmit-Receive Switch:

The functional schematic diagram for a diversity application of the switch is shown in Figure 1, with the required external components including 4 independent drivers at the control ports. When operation as a transfer switch is desired only 2 drivers are needed, one connected to the V1 and V3 ports together, and the other connected to the V2 and V4 ports. In either case, two DC return paths are needed for the control voltages, represented by the ground symbols in the diagram. These returns must be via oppositely situated RF ports (Tx and Rx or J1 and J2), and can be furnished incidentally by the user's RF terminating devices themselves. However, if those devices are AC-coupled (that is, they contain DC blocking capacitors), then the shunt resistors shown in the diagram are needed. The resistors should be installed either at the Tx and Rx ports (connection shown as solid), or at J1 and J2 (shown dotted), with equal effect. If one external RF device has a DC return to ground, for example, then only one resistor is needed; it must be installed at the opposite RF port of the switch. The resistance of each of the external DC returns should be 20K ohms or less, for proper ON/OFF FETs.

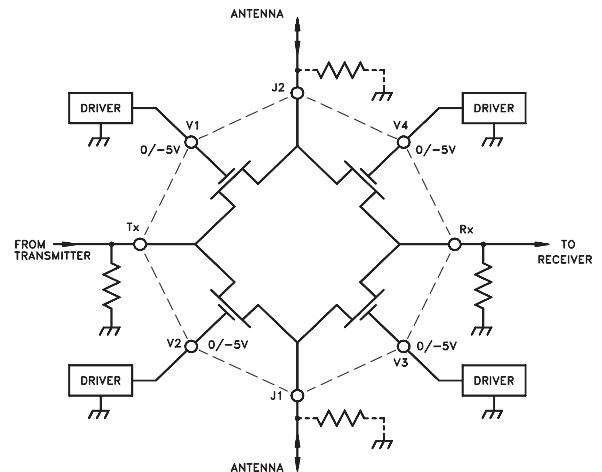

Figure 1. FUNCTIONAL SCHEMATIC DIAGRAM (Transmit-Receive application)

SUNSTAR 商斯达实业集团是集研发、生产、工程、销售、代理经销、技术咨询、信息服务等为一体的高科技企业，是专业高科技电子产品生产厂家，是具有 10 多年历史的专业电子元器件供应商，是中国最早和最大的仓储式连锁规模经营大型综合电子零部件代理分销商之一，是一家专业代理和分销世界各大品牌 IC 芯片和电子元器件的连锁经营综合性国际公司，专业经营进口、国产名厂名牌电子元件，型号、种类齐全。在香港、北京、深圳、上海、西安、成都等全国主要电子市场设有直属分公司和产品展示展销窗口门市部专卖店及代理分销商，已在全国范围内建成强大统一的供货和代理分销网络。我们专业代理经销、开发生产电子元器件、集成电路、传感器、微波光电元器件、工控机/DOC/DOM 电子盘、专用电路、单片机开发、MCU/DSP/ARM/FPGA 软件硬件、二极管、三极管、模块等，是您可靠的一站式现货配套供应商、方案提供商、部件功能模块开发配套商。商斯达实业公司拥有庞大的资料库，有数位毕业于著名高校——有中国电子工业摇篮之称的西安电子科技大学（西军电）并长期从事国防尖端科技研究的高级工程师为您精挑细选、量身订做各种高科技电子元器件，并解决各种技术问题。

微波光电部专业代理经销高频、微波、光纤、光电元器件、组件、部件、模块、整机；电磁兼容元器件、材料、设备；微波 CAD、EDA 软件、开发测试仿真工具；微波、光纤仪器仪表。欢迎国外高科技微波、光纤厂商将优秀产品介绍到中国、共同开拓市场。长期大量现货专业批发高频、微波、卫星、光纤、电视、CATV 器件：晶振、VCO、连接器、PIN 开关、变容二极管、开关二极管、低噪晶体管、功率电阻及电容、放大器、功率管、MMIC、混频器、耦合器、功分器、振荡器、合成器、衰减器、滤波器、隔离器、环行器、移相器、调制解调器；光电子器件和组件：红外发射管、红外接收管、光电开关、光敏管、发光二极管和发光二极管组件、半导体激光二极管和激光器组件、光电探测器和光接收组件、光发射接收模块、光纤激光器和光放大器、光调制器、光开关、DWDM 用光发射和接收器件、用户接入系统光收发器件与模块、光纤连接器、光纤跳线/尾纤、光衰减器、光纤适配器、光隔离器、光耦合器、光环行器、光复用器/转换器；无线收发芯片和模组、蓝牙芯片和模组。

更多产品请看本公司产品专用销售网站：

商斯达中国传感器科技信息网：<http://www.sensor-ic.com/>

商斯达工控安防网：<http://www.pc-ps.net/>

商斯达电子元器件网：<http://www.sunstare.com/>

商斯达微波光电产品网：[HTTP://www.rfoe.net/](http://www.rfoe.net/)

商斯达消费电子产品网：<http://www.icasic.com/>

商斯达实业科技产品网：<http://www.sunstars.cn/> 微波元器件销售热线：

地址：深圳市福田区福华路福庆街鸿图大厦 1602 室

电话：0755-82884100 83397033 83396822 83398585

传真：0755-83376182 (0) 13823648918 MSN: SUNS8888@hotmail.com

邮编：518033 E-mail:szss20@163.com QQ: 195847376

深圳赛格展销部：深圳华强北路赛格电子市场 2583 号 电话：0755-83665529 25059422

技术支持：0755-83394033 13501568376

欢迎索取免费详细资料、设计指南和光盘；产品凡多，未能尽录，欢迎来电查询。

北京分公司：北京海淀区知春路 132 号中发电子大厦 3097 号

TEL: 010-81159046 82615020 13501189838 FAX: 010-62543996

上海分公司：上海市北京东路 668 号上海赛格电子市场 D125 号

TEL: 021-28311762 56703037 13701955389 FAX: 021-56703037

西安分公司：西安高新开发区 20 所(中国电子科技集团导航技术研究所)

西安劳动南路 88 号电子商城二楼 D23 号

TEL: 029-81022619 13072977981 FAX:029-88789382