

Oxygen MediceL[®] Specification

In-Q-OX MediceL[®]

Not suitable for use with anaesthetic gases



N.B. All performance data is based on conditions at 23°C, 50%RH, and 1013mBar unless otherwise stated

Performance Characteristics

Output	7 - 14mV in 210mBar O ₂
Range	0 - 100% O ₂
Resolution	±1 mBar O ₂
Expected Operating Life	11 months in 100% O ₂ at 23°C±2°C 700,000%O ₂ hrs at 23°C±2°C 15 months in 50% O ₂ at 37°C 550,000%O ₂ hrs at 37°C
T₉₀ Response Time	<5 seconds
Linearity	>0.9999 in 4 gas medical test
Baseline at 20°C	<100µV
Temperature Range	-20°C to +50°C
Temperature Compensation	<3% signal change (over range 20°C to 40°C)
Differential Pressure Range	0 to 500mBar max
Absolute Pressure Range	500 to 2000mBar
Relative Humidity Range	0 to 99% non-condensing
Typical Long Term Output Drift in Air	<10% signal loss/year
Pressure Transient	NA
Repeatability	<±1% of signal
Cross Sensitivity	Meets EN12598 and EN60601-2-19 requirements

Physical Characteristics

Weight	40g (approx.)
Housing Material	White ABS
Packaging	Sealed blister packaging
Position Sensitivity	None
Storage Life	6 months in CTL container
Recommended Storage Temperature	0-20°C
Warranty Period	12 months from date of despatch

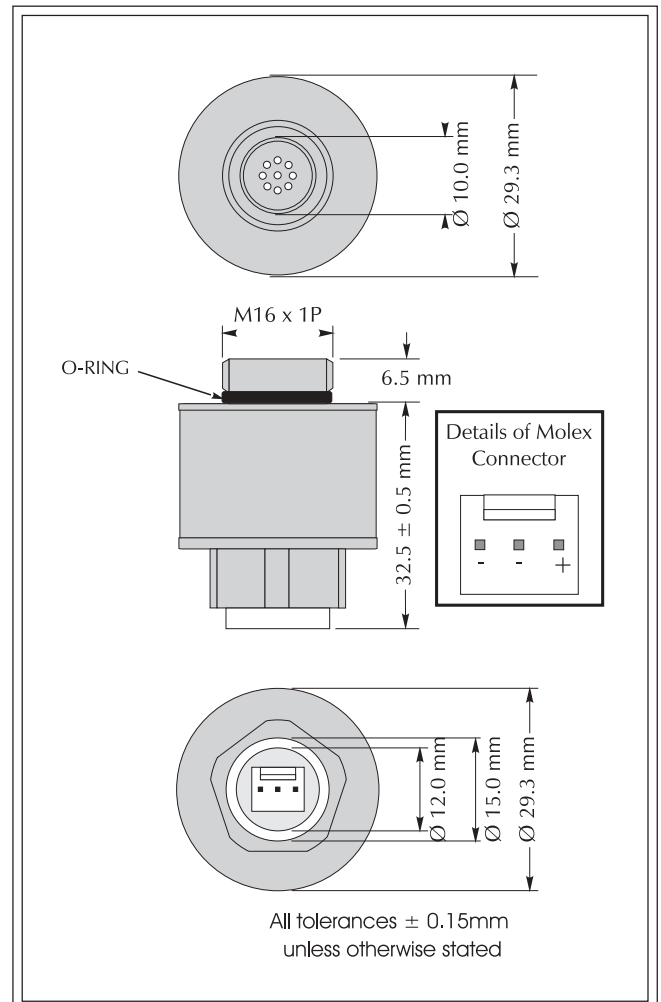

NOTE

Molex header used in sensor is MOLEX 22-29-2031
Suggested mating parts are:
Molex 22-01-2035: 3-way housing
Molex 08-56-0110: crimp terminals



Oxygen MediceL[®] Specification



Intended Use

These sensors are designed to be used to monitor the partial pressure of oxygen in non-anaesthesia oxygen monitors, incubators and CPAP equipment.

Stabilisation time

Allow at least 15 minutes to stabilise in instrument before calibration.

Cleaning and Sterilisation

In case of contamination the sensor may be cleaned with distilled water and allowed to dry naturally. The sensor is not suitable for sterilisation by steam or exposure to chemicals such as ethylene oxide or hydrogen peroxide. After cleaning the sensor should be calibrated.

Calibration Interval

These sensors are designed to have minimal drift over their useful lifetime however for maximum accuracy they should be calibrated in 100% Oxygen before use. If a sensor is dropped then it should be placed in quarantine for 24 hours followed by a 2 point calibration.

Cross-sensitivity

Test Gas	Error (% O ₂)
50% He/50% O ₂	<1%
5% CO ₂ / 28.5% O ₂ /66.5% N ₂ O	<1%

Temperature Performance

IN-Q-OX - % Signal Change from 20°C vs Temperature (°C)
Pressure compensated data

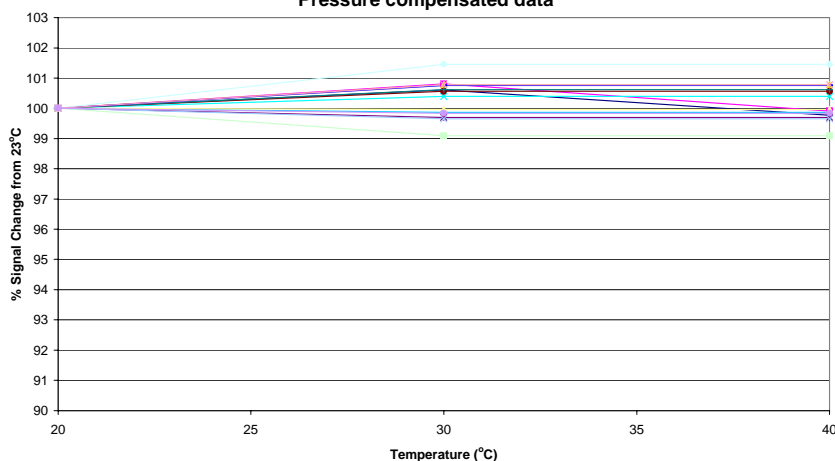

Every effort has been made to ensure the accuracy of this document at the time of printing. In accordance with the company's policy of continued product improvement City Technology Limited reserves the right to make product changes without notice. No liability is accepted for any consequential losses, injury or damage resulting from the use of this document or from any omissions or errors herein. The data is given for guidance only. It does not constitute a specification or an offer for sale. The products are always subject to a programme of improvement and testing which may result in some changes in the characteristics quoted. As the products may be used by the client in circumstances beyond the knowledge and control of City Technology Limited, we cannot give any warranty as to the relevance of these particulars to an application. It is the clients' responsibility to carry out the necessary tests to determine the usefulness of the products and to ensure their safety of operation in a particular application.

Performance characteristics on this data sheet outline the performance of newly supplied sensors. Output signal can drift below the lower limit over time.