

# USER'S GUIDE

## EE210 - Humidity and Temperature Transmitter for demanding Climate Control Applications

### GENERAL

The EE210 transmitter, available for wall or duct mounting, is designed for the highly accurate measurement of humidity and temperature in demanding climate control applications. The EE210 incorporates the E+E humidity and temperature sensor HCT01.

For use in special applications do not hesitate to contact E+E Elektronik or a local distributor.

### CAUTION

- For accurate measurement it is essential that the temperature of the sensing probe and mainly of the sensing head is same as the temperature of the air to measure. Avoid mounting the EE210 transmitter in a way which creates temperature gradients along the probe.
- The transmitter and mainly the sensing head shall not be exposed to extreme mechanical stress.
- The transmitter must be operated with the filter cap on at all times. Do not touch the sensors inside the sensing head.
- While replacing the filter cap (because of pollution for instance) against an original E+E spare one please take very good care to not touch the sensors.

### CONNECTION DIAGRAM

EE210-HT6\*

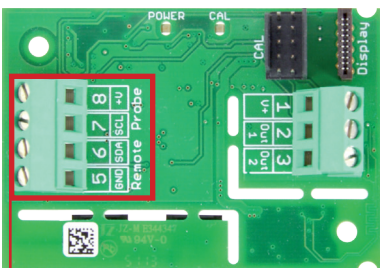

**ONLY FOR REMOTE PROBE!**

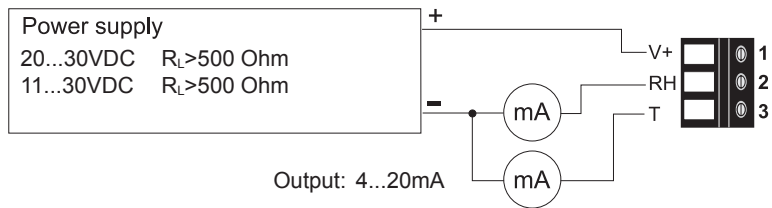

EE210-HT3

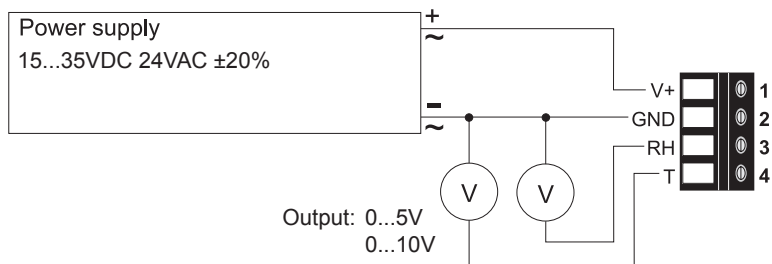
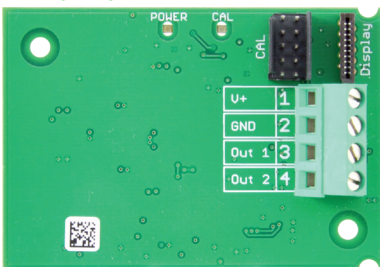

EE210-HTx3

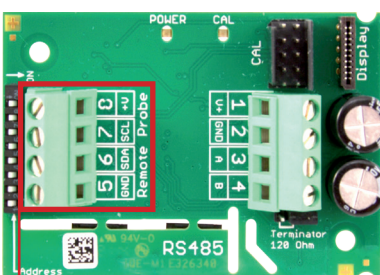

**ONLY FOR REMOTE PROBE!**

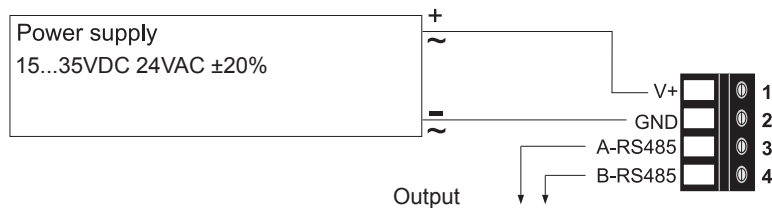

**\*Important:**

In the case of EE210-HT6 (4...20mA, two-wire version) the display operates only if both outputs are connected.

**EE210P (type C)**

The EE210P remote probe for EE210-HT6xPC (4 ... 20mA, 2-wire) and HTx3xPC (Modbus interface) shall be ordered and it is supplied as separate item. EE210P is to be connected to the EE210 by the user.

- Install first the cable gland onto the EE210 enclosure.
- Before connecting the probe, disconnect the power supply.
- Insert the EE210P cable through the cable gland and connect it to the screw terminals according to the connection diagram below.

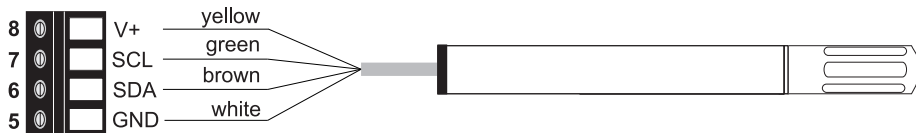

**Please note:**

EE210P is an intelligent probe with digital output and as such it is interchangeable. In case the probe or its cable gets destroyed or if a longer cable is needed, please order a replacement probe according to EE210 data sheet. The replacement probe shall be installed as described above.

**Important:**

Make sure that the cable glands are closed tightly for both EE210P probe cable and for the power supply and outputs cable. This is necessary for assuring the protection class (IP class) of the enclosure according to EE210 specification, as well as for stress relief at the screw terminals on the EE210 board.

**LED INDICATION**

*Green LED - information to normal operation mode:*

- on = everything OK
- flashing = the main board does not recognize the measurement electronics inside the sensing probe
- off = no power supply or main board failure

*Blue LED - information during setup with the optional E+E Configuration Kit:*

- on = E+E Product Configuration Adapter (EE-PCA) is powered, no communication in progress
- flashing = EE-PCA powered, communication in progress
- off = EE-PCA not connected to the EE210

**DISPLAY**

**Factory Setup:**

The display shows the two parameters selected for output 1 and output 2 (according to ordering code). For digital output versions the display shows RH and T.

**User Setup:**

The user can change the display layout to 1, 2 or 3 lines and select the parameters to be displayed by using EE-PCS Product Configuration Software (free download from [www.epluse.com/configurator](http://www.epluse.com/configurator)) and the optional EE-PCA Product Configuration Adapter (not included in the scope of supply).

**Important:**

In the case of EE210-HT6 (4..20mA, two-wire version) the display operates only if both outputs are connected.

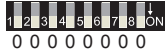

**Address Switch****Slave address setting via EE-PCS Product Configuration Software:**

All switches at position 0 → address has to be set via configuration software (factory setting 242).

*Example: Slave address is set via configuration software.*

**Address Switch****Slave address setting via Dip-Switch:**

Setting the Dip-Switch to any other address than 0 overwrites the slave address set via configuration software.

*Example: Slave address set to 11 (=00001011 binary).*

**MODBUS MAP**

The measured values are saved as a 32Bit float value from 0x19 to 0x1F and from 0x23 to 0x29. Additionally the measured values are available as 16Bit signed integer from 0x12C to 0x12F and from 0x131 to 0x134.

The factory setting for the Slave-ID (Modbus address) is 242 as an integer 16Bit value. This ID can be changed by the user in the register 60001 (0x00), permitted values are 1 - 247 permitted.

The serial number as ASCII-code is located at register address 30001-30008 (16Bit per address).

The Firmware version is located at register address 30009 (Bit 15...8 = major release; Bit 7...0 = minor release).

The choice of measurement units (metric or not metric) must be done in the ordering guide, see EE210 data sheet. Switching from metric to non metric or vice versa by using the EE-PCS is not possible.

**FLOAT (read register):**

Register address	Communication address	Parameter name	
30026	0x19	temperature	[°C], [°F]
30028	0x1B	relative humidity	[%]
30030	0x1D	water vapour partial pressure	[mbar], [psi]
30032	0x1F	dew point temperature	[°C], [°F]
30036	0x23	absolute humidity	[g/m³], [g/ft³]
30038	0x25	mixing ratio	[g/kg], [gr/lb]
30040	0x27	specific enthalpy	[kJ/kg], [BTU/lb]
30042	0x29	frost point temperature	[°C], [°F]

**INTEGER (read register):\***

Register address	Communication address	Parameter name	
30301	0x12C	temperature	[°C], [°F]
30302	0x12D	relative humidity	[%]
30303	0x12E	water vapour partial pressure	[mbar], [psi]
30304	0x12F	dew point temperature	[°C], [°F]
30306	0x131	absolute humidity	[g/m³], [g/ft³]
30307	0x132	mixing ratio	[g/kg], [gr/lb]
30308	0x133	specific enthalpy	[kJ/kg], [BTU/lb]
30309	0x134	frost point temperature	[°C], [°F]

\* Values are stored with a scaling of 1:100 (e.g.: 2550 is equivalent to 25.5°C)

**INFO (read register):**

Register address	Communication address	Parameter name
30001	0x00	Serial number
30009	0x08	Firmware version

**INTEGER (write register):\***

Register address	Communication address	Parameter name
60001	0x00	Slave-ID (modbus address)
60002	0x01	Modbus protocol settings*

\*For Modbus protocol setting please see Application Note Modbus ([www.epluse.com/EE210](http://www.epluse.com/EE210))

**Protocol setting:**

Address, baudrate, parity and stop bits can be set via:

1. Configurator software (available on [www.epluse.com/EE210](http://www.epluse.com/EE210))
2. Modbus protocol (please see Application Note Modbus (available on [www.epluse.com/EE210](http://www.epluse.com/EE210)))

**TECHNICAL DATA**

(Modification rights reserved)

**Measured Values****Relative Humidity**

Sensor	E+E Sensor HCT01-00D	
Analog output 0...100% RH	0-5 V	-1 mA < I <sub>L</sub> < 1 mA
	0-10 V	-1 mA < I <sub>L</sub> < 1 mA
	4-20 mA (two-wire)	R <sub>i</sub> ≤ 500 Ohm

Working range 0...100% RH

RH accuracy (incl. hysteresis, non-linearity and repeatability)

Wall &amp; duct version:

-15...40°C (5...104°F) ≤90% RH	±(1.3 + 0.003*measured value) % RH
-15...40°C (5...104°F) >90% RH	± 2.3% RH
-40...60°C (0...140°F)	±(1.5 + 0.015*measured value) % RH

Remote probe version

at 20°C (68°F) ±2.5% RH

**Temperature**

Sensor	Pt1000 (tolerance class B, DIN EN 60751) integrated in HCT01	
Analog output <sup>1)</sup>	0-5 V	-1 mA < I <sub>L</sub> < 1 mA
	0-10 V	-1 mA < I <sub>L</sub> < 1 mA
	4-20 mA	R <sub>i</sub> ≤ 500 Ohm

T-accuracy

wall &amp; duct

remote probe

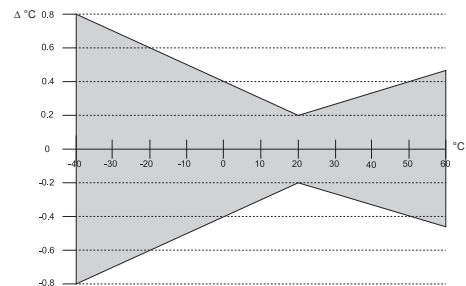
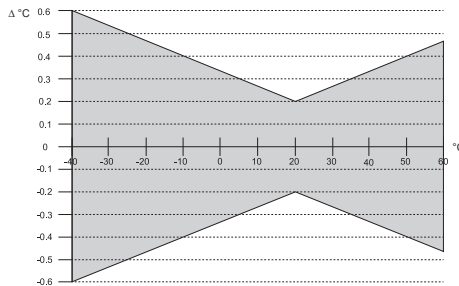
**General**

Power supply	for 0-5 V / 0-10 V	15 - 35V DC <sup>2)</sup> or 24V AC ±20%
	for 4-20 mA	10V + R <sub>i</sub> x 20 mA < V+ < 30V DC
Current consumption		
Voltage output		DC supply typ. 3.3mA; with display typ. 3.6mA
		AC supply typ. 34mA; with display typ. 37mA
Current output		DC supply max. 40mA
Digital interface		DC supply typ. 5mA; with display typ. 19mA
		AC supply typ. 52mA; with display typ. 118mA
Connection		Screw terminals, max. 1.5 mm <sup>2</sup>
Housing material		Polycarbonate, UL94V-0 (with Display UL94HB) approved
Protection class		IP65
Cable gland		M16 x 1,5
Probe cable (type C)		PVC, Ø 4.3mm, 4 x 0.25 mm <sup>2</sup>
Sensor protection		E+E Coating
Electromagnetic compatibility		EN61326-1 EN61326-2-3 Industrial Environment
Temperature ranges		Operating temperature: -40...60°C (-40...140°F)
		Storage temperature: -40...60°C (-40...140°F)
Temperature ranges with display		Operating temperature: -20...50°C (-4...122°F)
		Storage temperature: -20...60°C (-4...140°F)

<sup>1)</sup> Output scaling see Ordering Guide<sup>2)</sup> USA & Canada: class 2 supply required, max. supply voltage 30V

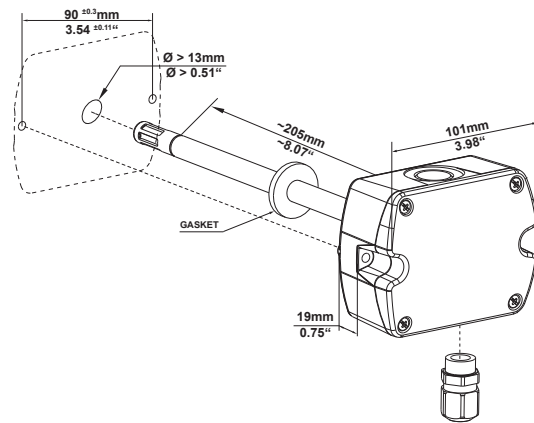
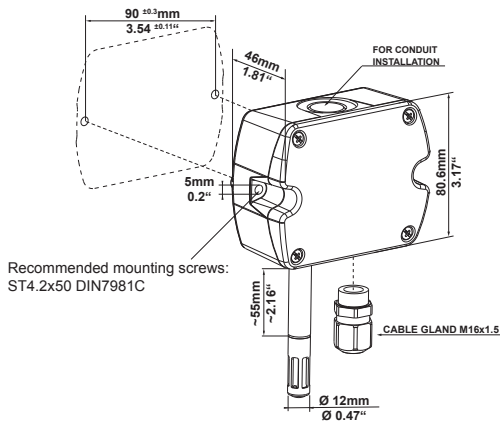

**Typ C**

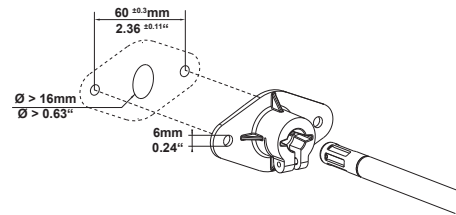
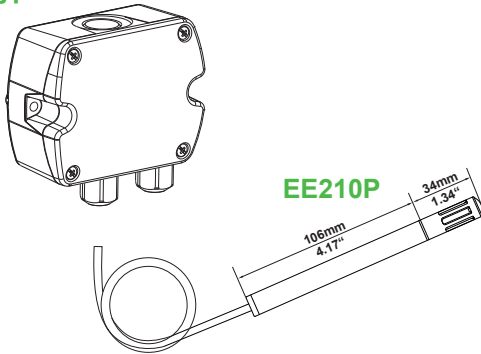

**SETUP AND ADJUSTMENT**

The EE210 transmitter is ready to use and does not require any configuration by the user. The factory setup of EE210 corresponds to the type number ordered. (Ordering guide please see data sheet at [www.epluse.com/EE210](http://www.epluse.com/EE210).)

If needed, the user can change the factory setup by using the optional E+E Product Configuration Adapter (EE-PCA) and the E+E Product Configuration Software (EE-PCS).

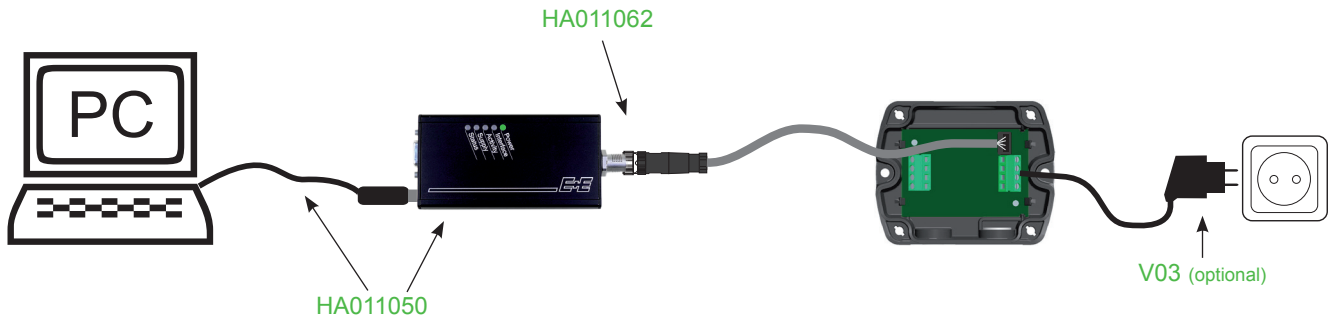

One can assign other physical quantities to the analogue outputs, change the scaling of the outputs and perform one or two point adjustment for humidity and temperature.

For product data sheets EE-PCS and EE-PCA please see [www.epluse.com](http://www.epluse.com).

The E+E Product Configuration Software (EE-PCS) is free and can be downloaded from [www.epluse.com/configurator](http://www.epluse.com/configurator).

**MAINTENANCE**

When employed in dusty, polluted environment:

- The filter cap shall be replaced once in a while with an E+E original one. A polluted filter cap causes longer response time of the device.
- If needed, the sensing head can be cleaned. For this remove first very carefully the filter cap. Take care not to hit the sensing head. Shake slowly the sensing head for one minute in a solution of 50% isopropyl alcohol with 50% distilled water. Then the sensing head shall be rinsed with cold tap water and let dry freely. Do not touch or rub the sensing head! After cleaning the sensors install carefully a new E+E original filter cap.

**Configuration kit:** The configuration kit allows user setup for the output scaling and for the interface parameters, as well as humidity and temperature adjustment of the sensor.

**Position 1:**

- configuration adapter (incl. USB cable for PC) [EE-PCA](#)

**Position 2:**

- cable for configuration adapter [HA011062](#)

**Position 3:**

- configuration software:  
free of charge; download: [www.epluse.com/EE210](http://www.epluse.com/EE210) [EE-PCS](#)

**Position 4 - optional:**

- power supply for EE210 [V03](#)

## INFORMATIONEN

+43 7235 605 0 / [info@epluse.com](mailto:info@epluse.com)

Langwiesen 7 • A-4209 Engerwitzdorf  
Tel: +43 7235 605-0 • Fax: +43 7235 605-8  
[info@epluse.com](mailto:info@epluse.com) • [www.epluse.com](http://www.epluse.com)

LG Linz Fn 165761 t • UID-Nr. ATU44043101  
Place of Jurisdiction: A-4020 Linz • DVR0962759

