

# MINIATURE THERMOPILE DETECTORS FOR GAS SENSING AND MEASUREMENT



## TPD 0223, TPD 0623 Thermopile

### Applications

- Non-contact temperature measurements
- IR based gas sensors

### Features and Benefits

- TO-46 metal housing
- Square window
- Optical filter options
- Thermistor included

### Product Description

This is our range of general-purpose miniature thermopile detectors in 4.7 mm diameter TO-46 type housings. Both feature a specially-designed element configuration, each one with a different size of absorbing area. The window is available as standard infrared or as narrow band pass filter for gas sensing applications. The TPD0223 provides the smallest absorbing area, the TPD 0623 is a larger design offering strong signals. Both types are equipped as standard with an internal thermistor as temperature reference for thermopile temperature compensation.

### Field of View

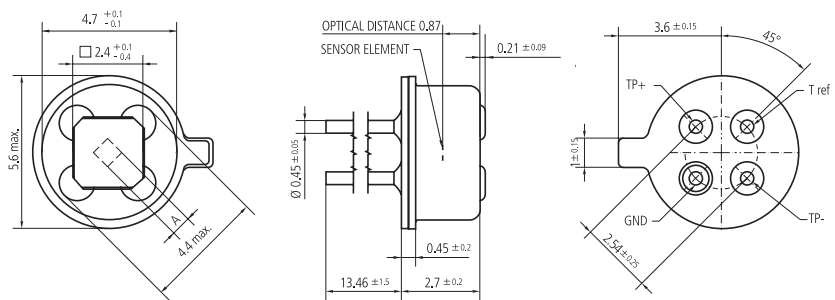
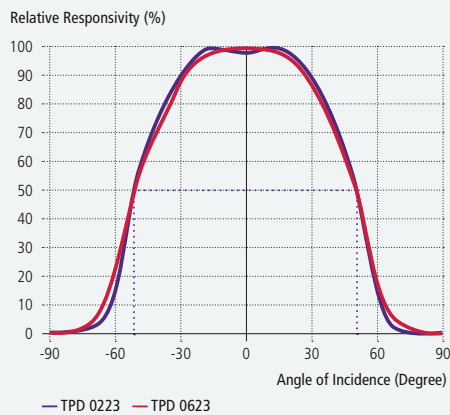

### TPD 0223, TPD 0623 Thermopile

Parameter	Symbol	0223	0623	Unit	Remark
Sensitive area	A	0.7 x 0.7	1.2 x 1.2	mm	Absorber area
Sensitive area	A	0.5	1.4	mm <sup>2</sup>	Absorber area
Thermopile resistance	R <sub>TP</sub>	50 ... 100	50 ... 110	kΩ	25° C
Responsivity	R	45	33	V/W	500° / 1Hz / without IR-filter
Sensitivity (T <sub>det</sub> 25° C / T <sub>obj</sub> 40° C)	S <sub>40</sub>	88	133	μV/K	With standard filter (LWP, cut-on 5.5 μm)
Sensitivity (T <sub>det</sub> 25° C / T <sub>obj</sub> 100° C)	S <sub>100</sub>	116	177	μV/K	With standard filter (LWP, cut-on 5.5 μm)
Time constant	t	22	27	ms	
Noise voltage	V <sub>N</sub>	35	36	nV / √Hz	25° C
Specific detectivity	D*	0.9	1.1	10 <sup>8</sup> cm√Hz / W	25° C
Temp. coefficient of resistance	TC <sub>RTP</sub>	0.03	0.03	% / K	
Temp. coefficient of responsivity	TC <sub>R</sub>	-0.05	-0.05	% / K	
Field of view	FoV	104	104	Degrees	At 50% intensity points
Thermistor resistance (25° C)	R <sub>25</sub>	100	100	kΩ	25° C
Thermistor BETA-value	β	3964	3964	K	Defined at 25° C / 100° C