

ACULED[®]

RGGB

ACL00-MC-GBGR-005-C02-L-0000



Superior brightness and excellent color mixing in a compact size, ACULED is truly “setting the mood” with illumination. Test it out with our Evaluation Kit.

Overview

Excelitas' ACULED - or All Color Ultrabright LED - is a multiuse, compact LED designed for operation in specialty lighting applications.

Typical applications include mood lighting, indoor/outdoor illumination, architectural or stage lighting, automotive interior lighting and much more.

The ACULED is a high-power light source utilizing multi chip-on-board (COB) technology. The close chip placement achieves an exquisite white color mix. Excellent multi-color mixing is also achievable by driving each chip individually using one blue, one red, and two green power chips. Each color has a separate anode and cathode. The two green chips are serially connected; additional optics can be easily attached.

The Excelitas ACULED boasts a compact size and superior optical design. In addition, the copper board provides for superior thermal conductivity.

An Evaluation Kit is also available for testing.

With global resources and manufacturing capabilities, Excelitas customers continue to benefit from the company's years of experience and expertise in LED technology and specialty lighting applications.

Features and Benefits

- ▶ High-power light source utilizing multi chip-on-board (COB) technology
- ▶ Superior brightness resulting from excellent quality LED chips and superior thermal management
- ▶ Compact size
- ▶ Excellent color mixing achieved by a separate anode and cathode for each color (red, green, blue)
- ▶ Close individual chip placement to produce an exquisite white color mix
- ▶ One blue, one red and two green chips (green connected serially)
- ▶ Lambertian emitter with 120° aperture
- ▶ Up to 4.5 W electrical power
- ▶ Fully RoHS compliant and reflow solderable

Applications

- ▶ High-power light source for general illumination
- ▶ Vision systems
- ▶ Architectural lighting
- ▶ Mood lighting
- ▶ Medical lighting
- ▶ Backlighting
- ▶ Displays and signs

Table of Contents

Product Nomenclature	3
Average Lumen Maintenance Characteristics	3
Environmental Compliance	3
Ordering Information and Flux Characteristics	4
Table 1: Intensity Bins	4
Table 2: Wavelength Bins	4
Optical and Electronic Characteristics***	4
Maximum Ratings at 25°C	5
Tables of Characteristics	5
Mechanical and Electrical Specification	7
Reliability Information	8
Soldering	9
Hand Soldering	9
Cautions	9
Notes	10
Packaging	10
Optics	11
Heat Sink Recommendations	11
ACULED Evaluation Kit	11
ACULED VHL™ - Very High Lumen for the ACULED	11
ACULED DY0™ - Flexibility to "Design-Your-Own" High Power LED	11

Position	1	2	3	4	5	6	7	8	9	10	11	12	13	14	15	16	17	18	19	20	21	22	23	24	25	26	27	28	29	30	31	32
Order number	A	C	L	0	1	-	P	F	-	M	C	O	-	C1	C2	C3	C4	-	P	W	C	-	C	0	1	-	L	-	B	I	N	S
Example	A	C	L	0	0	-	M	C	-	0	0	0	-	G	B	G	R	-	0	0	5	-	C	0	2	-	L	-	N	2	5	0

<p>Position 1-3: Product name</p>	<p>Position 4-5: Product generation 00 = ACULED</p>	<p>Position 7-8: Product family SC: Single color MC: Multi-color OD: On demand (Design Your Own)</p>	<p>Position 10-12: Manufacturing code (BOM) Design-Your-Own: alpha-numerical code VHL: 000 (will typically be left out in datasheets)</p>	<p>Position 14-17: Pads C1-C4 U = UV D = Deep blue B = Blue C = Cyan G = Green Y = Yellow A = Amber R = Red I = Near infrared J = Infrared White: 3 = 3200 K 4 = 4500 K 5 = 5400 K 6 = 6500 K</p>	<p>Position 19: ESD-protection 0 = none</p>	<p>Position 20-21: Input-Power in Watts (T_B = 25°C at rated current)</p>	<p>Position 23-25: Package type 23: Substrate material C = copper IMS 24 + 25: 00 undefined 01 dielectric layer VHL-version 02 dielectric layer ACULED</p>	<p>Position 27: Beam pattern: 0 = not defined L = Lambertian</p>	<p>Position 29: Intensity bin alpha-numerical (0 = open)</p>	<p>Position 30-31: Color bin (00 = open); SC colored: wavelength (1, 2, 3, ...) SC white: area in xy diagram (A, B, C, ...) MC: wavelength combination (0, 1, 2, ...) OD: 00 MD: 00 Position 32: not used = 0</p>
--	--	---	--	---	--	--	---	---	---	---

Average Lumen Maintenance Characteristics

Typically, the lifetime for solid-state lighting devices, or LEDs, is derived from the percentage of initial light output that remains after a specific time period - generally referred to as lumen maintenance.

Excelitas projects that ACULED® products, operating at a forward current of 350 mA, will average 70% lumen maintenance after 30,000 hours of constant current operation with junction temperature maintained at or below 110° C.

This performance is based on three criteria - independent test data, Excelitas historical data from tests run on similar material systems, and internal ACULED® reliability testing. To achieve this level of lumen maintenance, all design limits included in this datasheet must be adhered to carefully.

Environmental Compliance

Excelitas is proud of its commitment to providing the best in environmentally- friendly products to customers in the solid state lighting market. The ACULED® is no exception - and complies with the European Union directives on the restriction of hazardous substances in electronic equipment as stated within the RoHS directive. The following restricted materials will not intentionally be added to the ACULED® - lead, mercury, cadmium, hexavalent chromium, polybrominated biphenyls (PBB) or polybrominated diphenyl ethers (PBDE).

Board temperature $T_B=25^\circ\text{C}$

Part-Number	Description	Type	Color	Luminous Flux Φ_v [lm]		Luminous Intensity I_v [cd]
				$I_F=350\text{ mA}$		$I_F=350\text{ mA}$
				Min.	Typ.	Typ.
E000986	ACULED GBGR	ACL00-MC-GBGR-005-C02-L-N000	Red Green ¹ Blue	Total 64	19 57 4.7	9 16 1.5

¹ two chips in series

Table 1: Intensity Bins

Board temperature $T_B = 25^\circ\text{C}$; $I_F = 350\text{ mA}$

Luminous Flux Φ_v [lm]		
Rank	Min.	Max.
L	40	64
M	51	81
N	64	102
O	81	128
P	102	161

Table 2: Wavelength Bins

Board temperature $T_B = 25^\circ\text{C}$; $I_F = 350\text{ mA}$

Dominant Wavelength λ_{dom} [nm]			
Rank	Red	Green	Blue
22	620-630	515-520	455-460

Optical and Electronic Characteristics***

Ambient temperature $T_A = 25^\circ\text{C}$, $I_F = 350\text{ mA}$

Parameter	Symbol	Red	Green	Blue	Unit
Luminous flux*	Φ_v	22	60	4.8	lm
Luminous flux**	Φ_v	19	57	4.7	lm
Luminous intensity*	I_v	12	17	1.5	cd
Luminous intensity**	I_v	9	16	1.5	cd
Dominant wavelength***	λ_{dom}	625	518	458	nm
Peak emission wavelength	λ_{peak}	638	513	452	nm
Spectral half bandwidth	$\Delta\lambda$	20	35	25	nm
Forward voltage per chip	V_F	2.3	6.6	3.3	V
Optical efficacy*	η_{opt}	27	25	4	lm/W
Optical efficacy**	η_{opt}	24	25	4	lm/W
Temperature coefficient for λ_{dom}	$TC(\lambda_{dom})$	0.05	0.05	0.04	nm/K
Temperature coefficient for λ_{peak}	$TC(\lambda_{peak})$	0.14	0.04	0.05	nm/K
Temperature coefficient for V_f per chip	$TC(V_f)$	- 2.6	- 4.4	- 4.3	mV/K
Viewing angle at 50%	2Ψ	130			degree
Radiating surface	A_{rad}	1.0	2x1.0	1.0	mm ²
Luminance*		690			Cd/cm ²
Luminance**		600			Cd/cm ²
Thermal resistance junction - board	R_{thJB}	10			K/W

* Values for junction temperature $T_J = 25^\circ\text{C}$

** Values for board temperature of $T_B = 25^\circ\text{C}$

For intensity rank N; all colors operated separately

Adequate heat sink is required. Derating must be observed to maintain junction temperature below maximum.

Parameter	Symbol	Value	Unit
Operating temperature range	T _{op}	-40 to 100	°C
Storage temperature	T _{st}	-40 to 100	°C
Junction temperature	T _J	125	°C
Forward current per chip	I _F	350	mA
Surge current per chip	I _{FM}	700	mA
Forward voltage per chip @ 350 mA	V _F	3 (R) / 8 (G) / 3.8 (B)	V
Reverse voltage per chip	V _R	5	V
Reverse current (V _R =5 V)	I _R	2	μA
Power consumption @ 350 mA	P _{tot}	5.2	W
ESD sensitivity		2	kV
Soldering temperature	Reflow (10 sec)	T _{sold}	260
	Hand (3 sec.)	T _{sold}	400

Tables of Characteristics

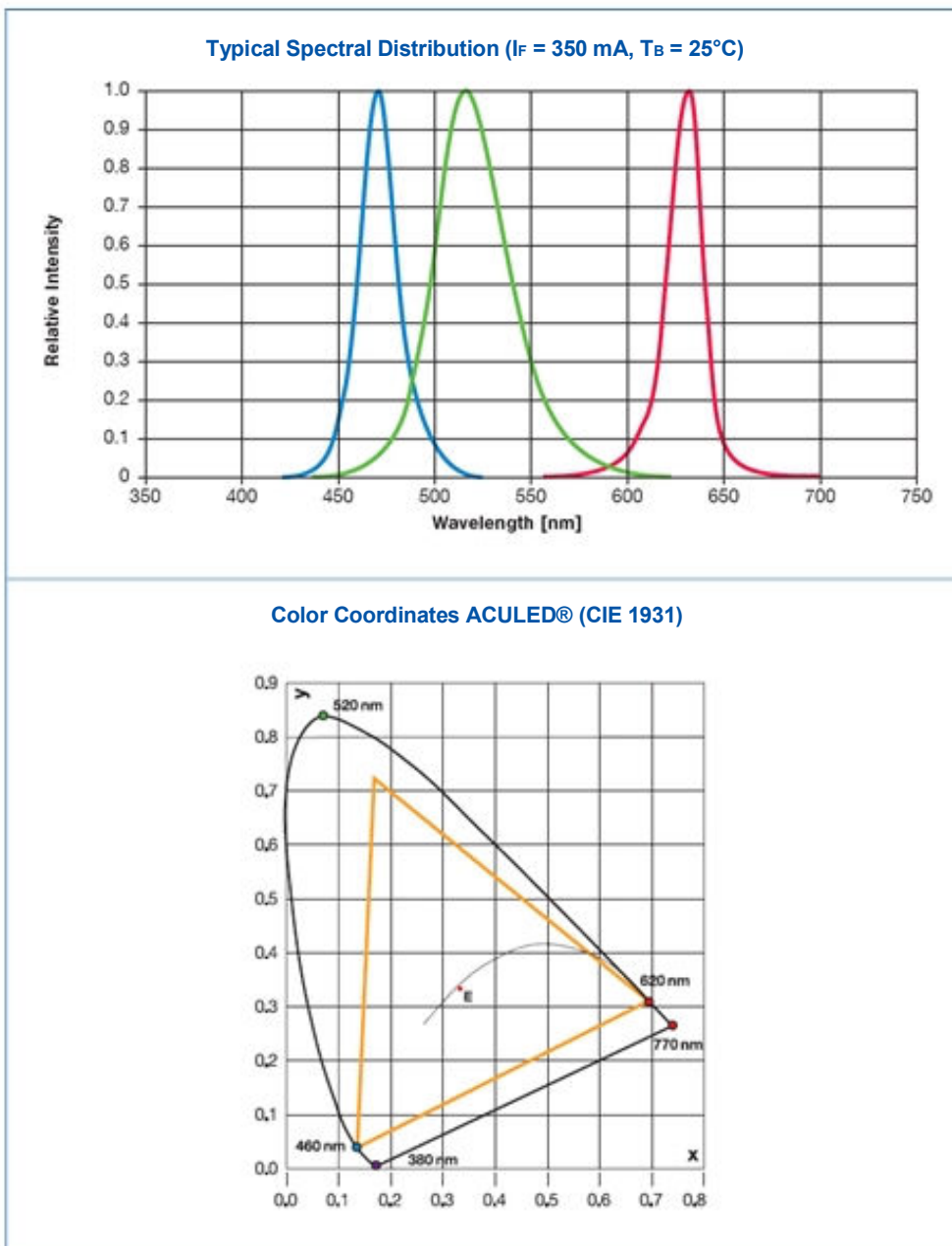

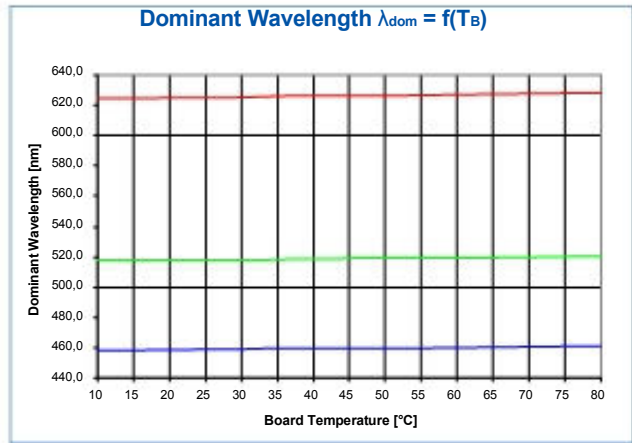
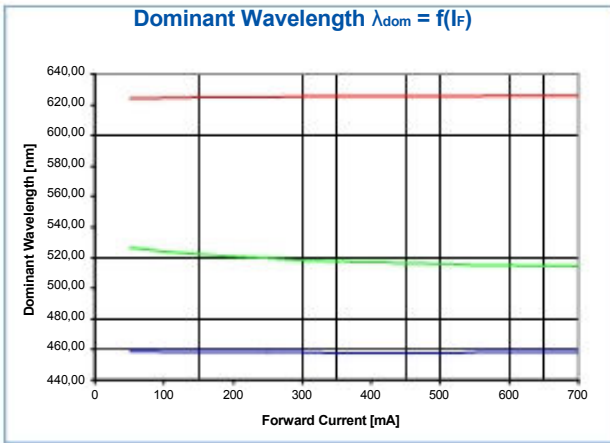
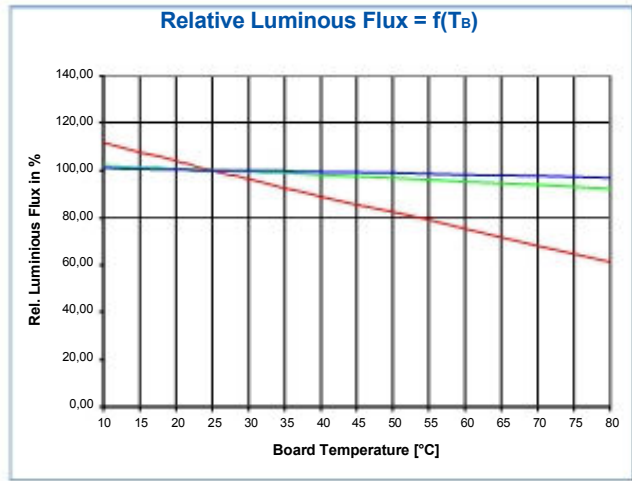
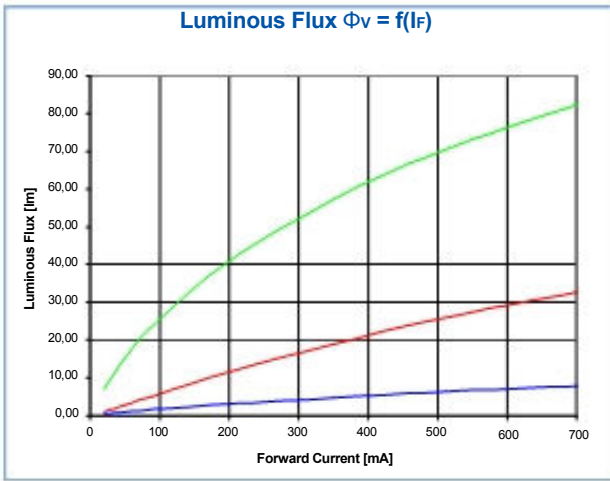
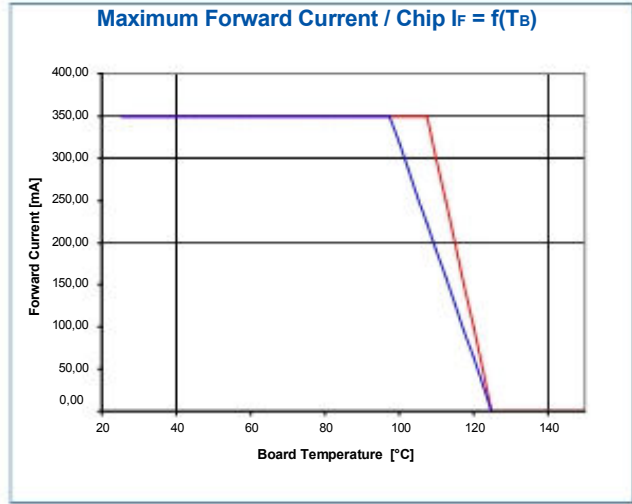
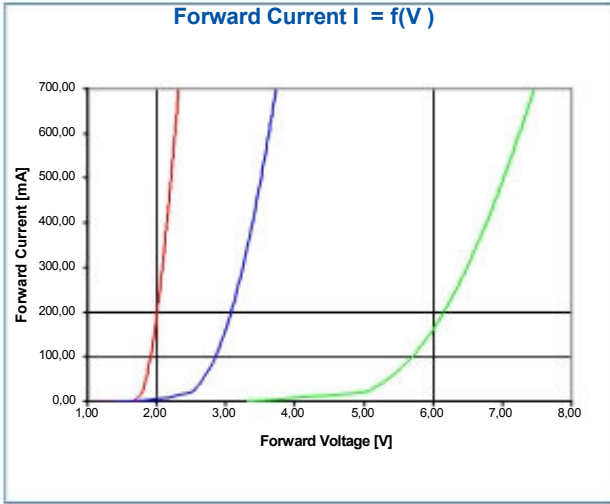

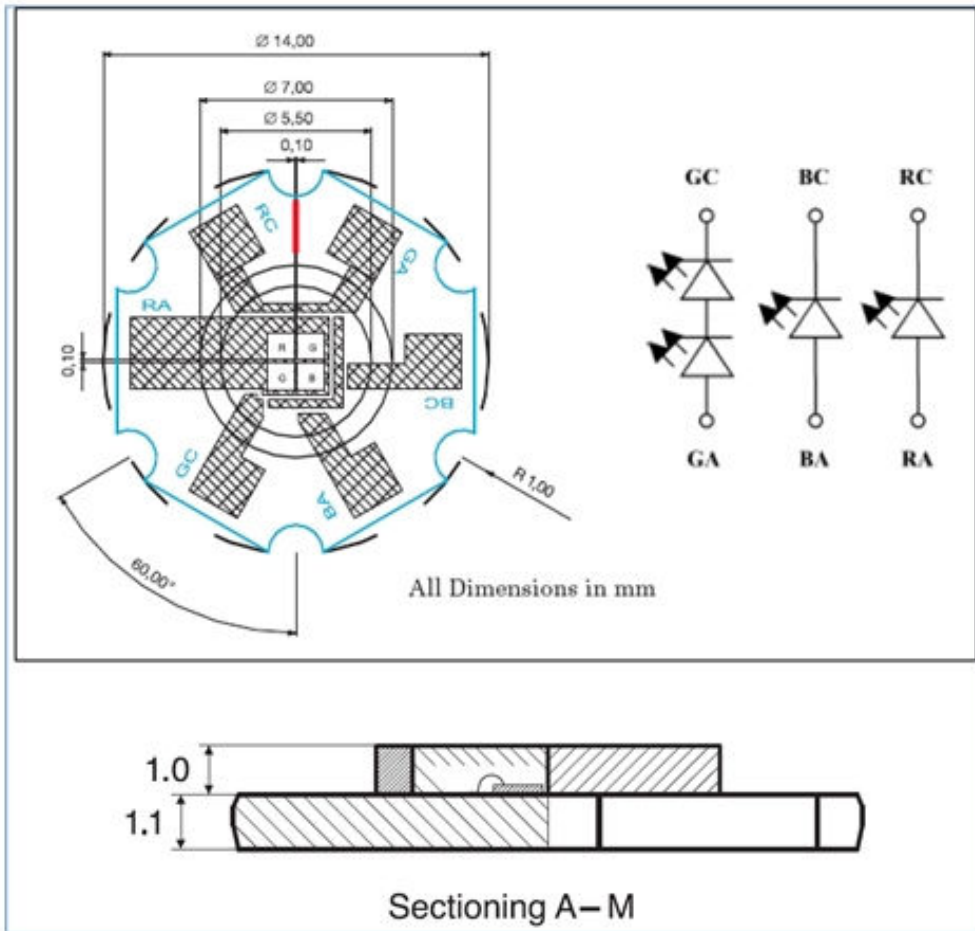

Package:	IMS
Encapsulating Resin:	Silicone
Ring:	PPA based
Electrodes:	Au Plating

Excelitas Reliability Test Program					
Test Item	Content of Test	Test Condition	Remarks	Measurement	Ref. Standard
Resistance to Soldering Heat (Reflow Soldering)	Stability of the device for RoHS conform soldering conditions	$T_{\text{solid}} = 260^{\circ}\text{C}$ for 10s (Pre treatment of the DUT: $T_{\text{solid}}=30^{\circ}\text{C}$, 70%, 12h)	One soldering cycle. Non operation of DUT during test *)	Visual Inspection. Measurement of illuminance E_v before and after test.	JEDEC J-STD-020C
Temperature Cycle Test, TCT	Stability of device under thermal stress, fast change of temperature	$T_A = -40^{\circ}\text{C}$ to 120°C dwell time: 30 min cycles: 200, cycle time: 1h	Operation of DUT at 10% of nominal current *)	Visual Inspection. Measurement of E_v after 0, 100, 200 cycles	IEC 60068-2-14
High Temperature Test, HTS	Stability of device at long term storage at high temp.	$T_A = 110^{\circ}\text{C}$ test duration: 1000h	Operation of DUT at 10% of nominal current *)	Visual Inspection. Measurement of E_v after 0, 1000h	IEC 60068-2-2
Low Temperature Test, LTS	Stability of device at long term storage at low temp.	$T_A = -40^{\circ}\text{C}$ test duration: 1000h	Operation of DUT at 10% of nominal current *)	Visual Inspection. Measurement of E_v after 0, 1000h	IEC 60068-2-1
Temperature Humidity Storage, THS	Stability of device stored for a long term at high temperature and high humidity.	$T_{\text{env}} = 85^{\circ}\text{C}$ RH=85%, test duration: 1000h	Operation of DUT at 10% of nominal current *)	Visual Inspection. Measurement of E_v after 0, 1000h	IEC 60068-2-67
Operation Life Test	Stability of device operated under nominal conditions	$T_A = 25^{\circ}\text{C}$, RH=30%, test duration: 1000h	Operation of DUT at nominal current I_m *)	Visual Inspection. Measurement of E_v after 0, 250, 500, 1000h	IEC 60068-1
Steady State Operating Life of High Humidity Heat	Stability of device under electrical and thermal stress and high humidity	$T_A = 60^{\circ}\text{C}$ RH=90%, test duration: 1000h	Operation of DUT at nominal current I_m *)	Visual Inspection. Measurement of E_v after 0, 250, 500 and 1000h	IEC 60068-2-78
Operation Life Test at High Temperature	Stability of device at high junction temperature and operated at nominal current	$T_A = 85^{\circ}\text{C}$ test duration: 1000h	Operation of DUT at nominal current I_m *)	Visual Inspection. Measurement of E_v after 0, 250, 500 and 1000h	IEC 60068-2-2
Vibration Test	Stability of device under mechanical stress. Sinusoidal vibration	f=20-2000Hz acceleration: 200m/s^2 amplitude: ± 0.751 sweep rate: 3,2 octave/min	Number of cycles: 4, test duration: 3x16min Non-operation of DUT during test	Visual Inspection. Measurement of E_v before and after test.	IEC 60068-2-6
Electrostatic Discharge	Stability of device under electrostatic stress	Test Voltage=2kV (R=1,5k Ω , C=100pF)	Positive and negative discharges: 3x with ESD-generator. Non-operation of DUT during test	Visual Inspection. Measurement of illuminance before and after test.	JEITA ED-4701

*) The test is done after the sample is cooled down to room temperature

T_{solid} = Soldering temperature, T_A = Ambient temperature, $I_m=350\text{mA}$, DUT = Device under Test. The tests are performed on top of Excelitas standard heat sink.

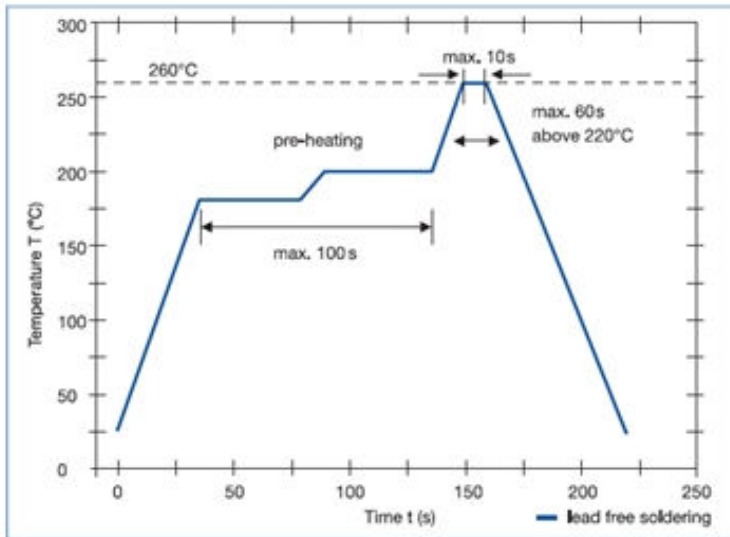

Figure 1
Reflow Soldering Profile

Hand Soldering

- Pre-heat ACULED on a hot plate at 100° C.
- Use 95 W soldering iron.
- Apply soldering temperature of 400° C for max. three seconds.

Cautions

Note: according IEC 60825-1 (EN 60826):
LED radiation. Do not view directly with optical instruments.

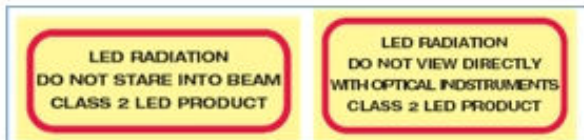

Notes

1. Excelitas maintains a tolerance of $\pm 5\%$ on flux and power measurements.
2. ACULED VHL products with even higher luminous flux and radiometric power levels will become available in the future.
3. Dominant wavelength is derived from the CIE 1931 chromaticity diagram and represents the perceived color.
4. Excelitas maintains a tolerance of ± 2 nm for dominant wavelength measurements.
5. Excelitas maintains a tolerance of ± 1 nm for peak wavelength measurements.
6. Excelitas maintains a tolerance of ± 2 K/W for thermal resistance measurements depending on chip properties.
7. Green and blue chips are based on Indium Gallium Nitride (InGaN).
8. Red chips are based on Aluminum Indium Gallium Phosphide (AlInGaP).
9. Blue chips represented here are IEC825 class 2 for eye safety.
10. Proper current derating must be observed to maintain junction temperature below the maximum.
11. LEDs are not designed to be driven in reverse bias.
12. Stresses in excess of the absolute maximum ratings can cause damage to the emitter. Maximum rating limits apply to each parameter in isolation, all parameters having values within the current derating curve. It should not be assumed that limiting values of more than one parameter can be applied to the product at the same time. Exposures to the absolute maximum ratings for extended periods can adversely affect device reliability.
13. Due to the special conditions of the manufacturing processes of LEDs, the typical data or calculated correlations of technical parameters can only reflect statistical figures. These do not necessarily correspond to the actual parameters of each single product, which could differ from the typical data and calculated correlations or the typical characteristic line. If requested, e.g. because of technical improvements, these typ. data will be changed without any further notice.
14. All drawings are not to scale.
15. All dimensions are specified in mm.
16. For general mounting instructions and thermal management requirements, please refer to our application notes accordingly.

Please consult Excelitas or its distributors for more information.

Packaging

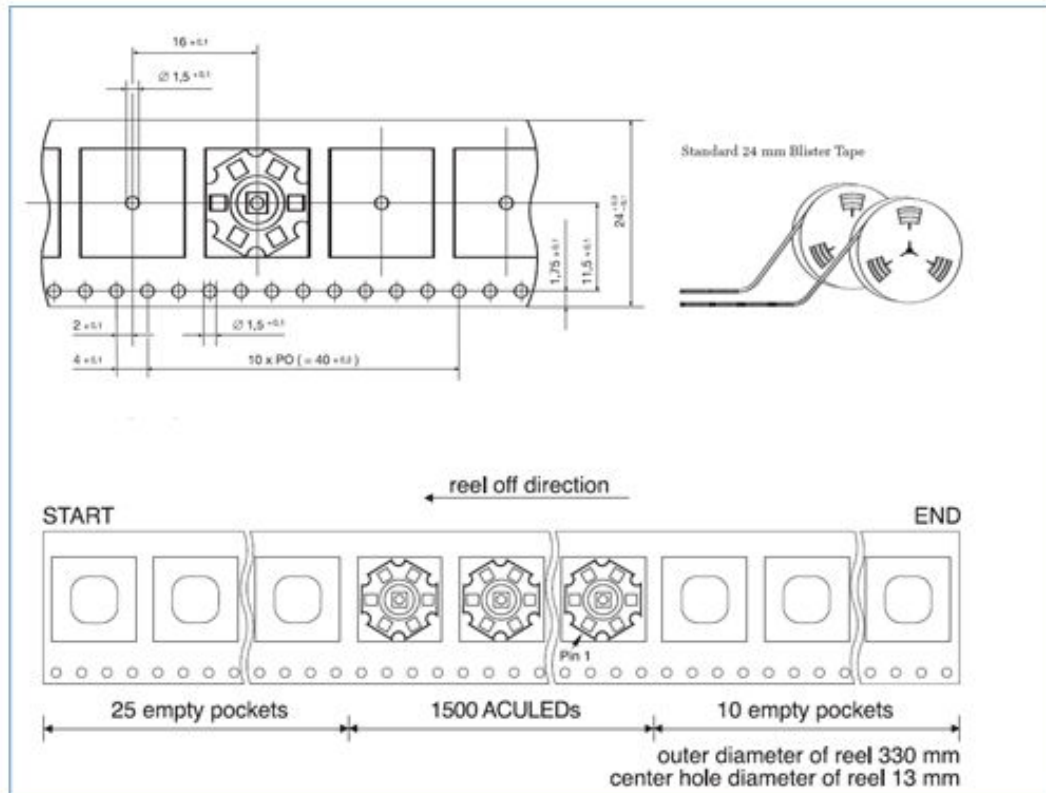

Currently, the ACULED lens holder system offers two different collimating optics. With an opening angle of approximately 32°, the ACULED LHS-AL25-L32 (E000525) provides a medium opening, whereas the LHS-AL25-L22 (E000524) has a tight collimating optic with an aperture angle of approximately 22°.

Due to their superior optical quality, both optics increase luminous intensity and, thereby, enable new application fields for the ACULED. Please contact us for further information or to receive the datasheet ACULED LHS-AL25.

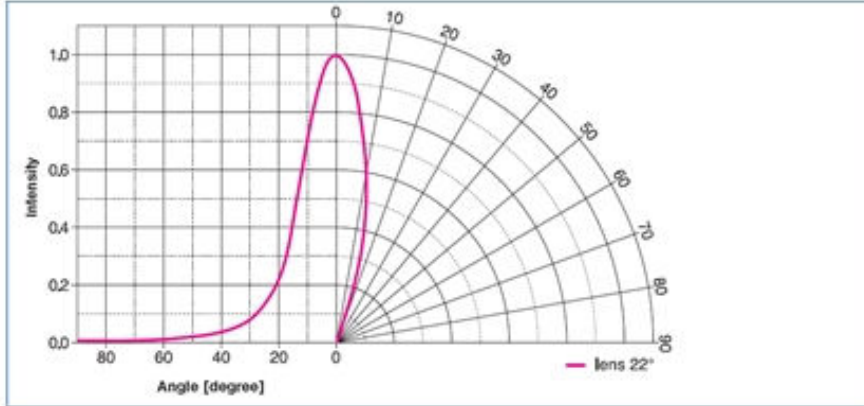

Figure 3
Opening Angle: Example
RGB with Lens

Heat Sink Recommendations

The maximum junction temperature of the ACULED should not exceed 125° C. Therefore, an adequate heat sink is required for operating the LED with currents between 50 mA and 350 mA. Due to the ACULED's superior thermal management, heat dissipation is optimized when the LED is screwed down with thermal grease onto a planar substrate.

ACULED Evaluation Kit

Excelitas has designed an Evaluation Kit to run and test the ACULED in your application. It is easy to use and does not require specialized technical know-how. Please contact us to receive a product description and additional information on how to obtain the Evaluation Kit.

ACULED VHL™ - Very High Lumen for the ACULED

Additionally to the RRGB ACULED Excelitas has extended and improved its product line by the ACULED VHL, Excelitas' new line of standard monochromatic and multi-colored high powered LEDs. This results in improved chip types, higher brightness and additional features. Please refer to the ACULED VHL datasheets accordingly.

ACULED DYO™ - Flexibility to "Design-Your-Own" High Power LED

Excelitas is also debuting its exclusive new "Design-Your-Own" line, the ACULED® DYO™. The ACULED DYO gives customers the total flexibility to design their own fourchip LED configuration to suit their specific application.

For more information on our new ACULED DYO line, please refer to the ACULED DYO Custom Design Guide.

North American Sales Office
Excelitas Technologies
35 Congress Street
Salem, MA 01970, USA
Telephone: +1 978-745-3200
Toll free: (North America) +1 800-950-3441
Fax: +1 978-745-0894
generalinquiries@excelitas.com
www.excelitas.com

European Headquarters
Excelitas Technologies
Wenzel-Jaksch-Str. 31
65199 Wiesbaden, Germany
Telephone: (+49) 611-492-247
Fax: (+49) 611-492-170

Asia Headquarters
Excelitas Technologies
47 Ayer Rajah Crescent #06-12
Singapore 139947
Telephone: (+65) 6775-2022
Fax: (+65) 6775-1008

EXCELITAS
TECHNOLOGIES

For a complete listing of our global offices, visit www.excelitas.com
©2011 Excelitas Technologies Corp. All rights reserved. The Excelitas logo and design are registered trademarks of Excelitas Technologies Corp. ACULED®, VHL™, and DYO™ are trademarks of Excelitas Technologies Corp. or its subsidiaries, in the United States and other countries. All other trademarks not owned by Excelitas Technologies Corp. or its subsidiaries that are depicted herein are the property of their respective owners. Excelitas reserves the right to change this document at any time without notice and disclaims liability for editorial, pictorial or typographical errors.
600034_07 DTS0108