

TPS 535 - Thermopile Detector

Large Absorber Size

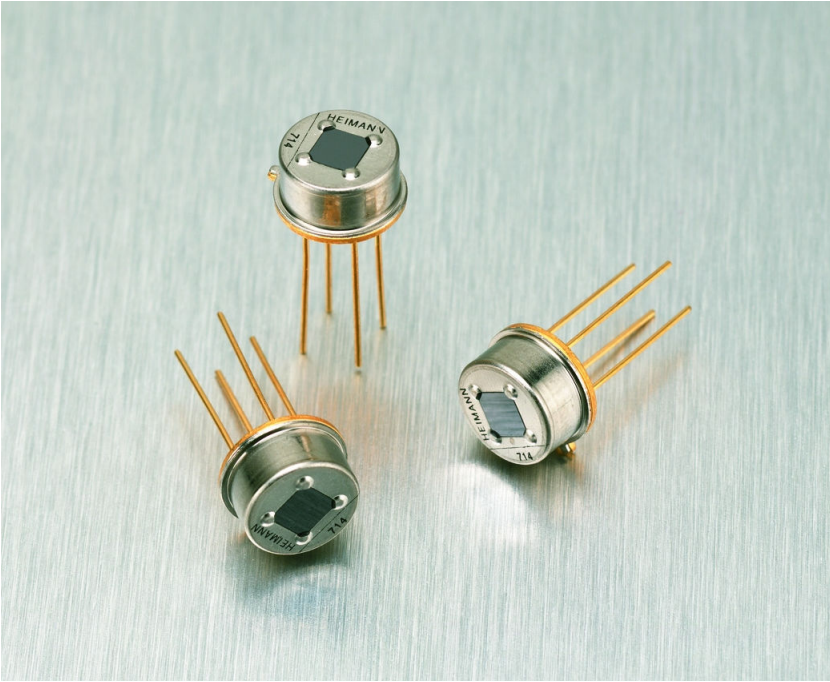

Description

The **TPS 535** thermopile sensor in a TO 5 type housing employs a chip of $1.2 \times 1.2 \text{ mm}^2$ absorber size and a $30 \text{ k}\Omega$ thermistor as temperature reference. The square window opening is equipped with a $5.5 \mu\text{m}$ longpass (standard) infrared filter. The sensor shows a flat sensitivity characteristic over the wavelength.

The TPS 535 can also be equipped with infrared bandpass filters for NDIR gas detection.

Features

- Large Absorber Size - High Signal Output
- Low Temperature Coefficient of Sensitivity
- Applications: Ear Thermometer, Gas Detectors (with Additional Infrared Bandpass Filter)

Figure 1. Package Drawing

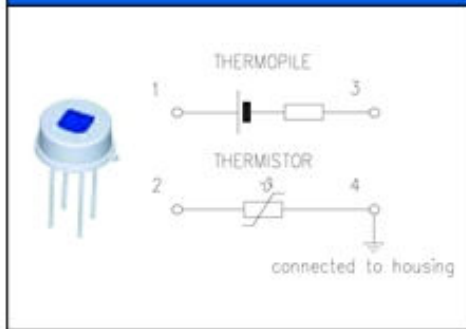

Figure 2.

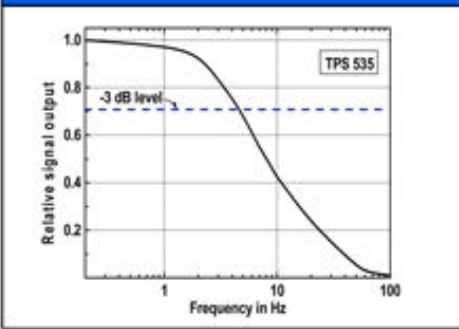

Figure 3.

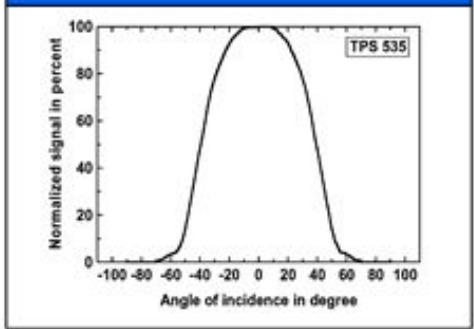

Figure 4. Top View Package Dimension

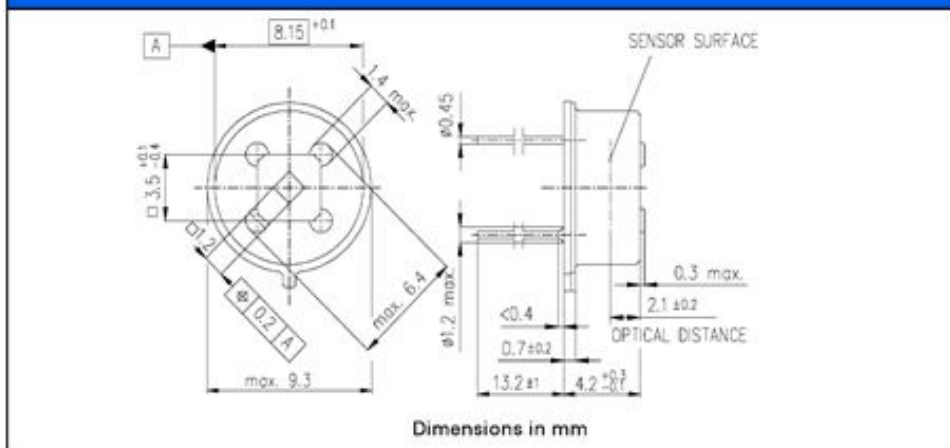

Figure 5. Bottom View

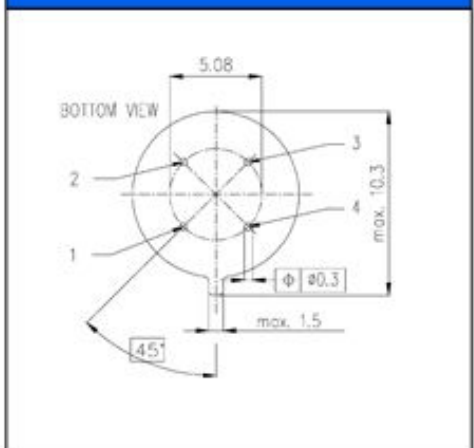

Table 1. TPS 534

Parameter	Typical	Units	Condition
Sensitive area	1.2 x 1.2	mm ²	absorbing area
Window size	3.5 x 3.5	mm	
DC sensitivity	20	V/W	500K BB 5 ... 14μm
Resistance	40	kΩ	
Noise	25	nV/√Hz	r.m.s. 300K
NEP	1.26	nW/√Hz	500K BB 5 ... 14μm
D*	0.96 x 10 ⁸	cm√Hz/W	500K BB 5 ... 14μm
TC of sensitivity	-0.01	%/K	
TC of resistance	0.02	%/K	
Time constant	35	ms	
Operating temperature	-40 to 100	°C	non permanent
Storage temperature	-40 to 100	°C	non permanent
Thermistor resistance	30	kΩ	25°C
beta	3964	K	25°C/100°C
Field of view	80	°	at 50% points

For more information email us at generalinquiries@excelitas.com or visit our website at [excelitas.com](http://www.excelitas.com)
 All values are nominal; specifications subject to change without notice.

North America:
 Excelitas Technologies
 16800 Trans-Canada Highway
 Kirkland, Quebec J7V 8P7 Canada
 Toll Free: (877) 734-OPTO (6786)
 Phone: +1-450-424-3300
 Fax: +1-450-424-3411

Europe:
 Excelitas Technologies
 Wenzel-Jaksch-Str. 31
 D-65199 Wiesbaden, Germany
 Phone: +49-611-492-430
 Fax: +49-611-492-165

Asia:
 Excelitas Technologies
 47 Ayer Rajah Crescent #06-12
 Singapore 139947
 Phone: +65-6770-4366
 Fax: +65-6775-1008

EXCELITAS
 TECHNOLOGIES