



**MINIATURE 5VDC OUTPUT  
IS® PRESSURE TRANSDUCER  
ETM-634(X)-312(M)**

- Smallest High Performance Amplified Transducer Worldwide
- High Temperature Electronics 365°F (185°C)
- Rugged Design Provides Compatibility With Most Corrosive and Conductive Media
- High Over Pressure Capability
- Aerospace Quality Components
- Designed and Engineered For Severe Environmental Conditions
- Intrinsically Safe Applications Available (i.e. IS-ETM-634-312)



The ETM-634X-312M is one of the newest generation of Kulite standard, smallest miniature amplified transducer currently available. The metal flush diaphragm is used as a force collector. Force is transferred to a solid-state piezoresistive sensing element via thin intervening film of non-compressible

silicone oil. This sensing sub-assembly is protected from mechanical damage by a protective screen, which has been shown to have minimal influence of the frequency response of the sensor. Incorporation of Kulite proprietary high temperature 365°F (185°C) electronics within the main body allows for operation from an unregulated power supply of 8 to 16VDC.

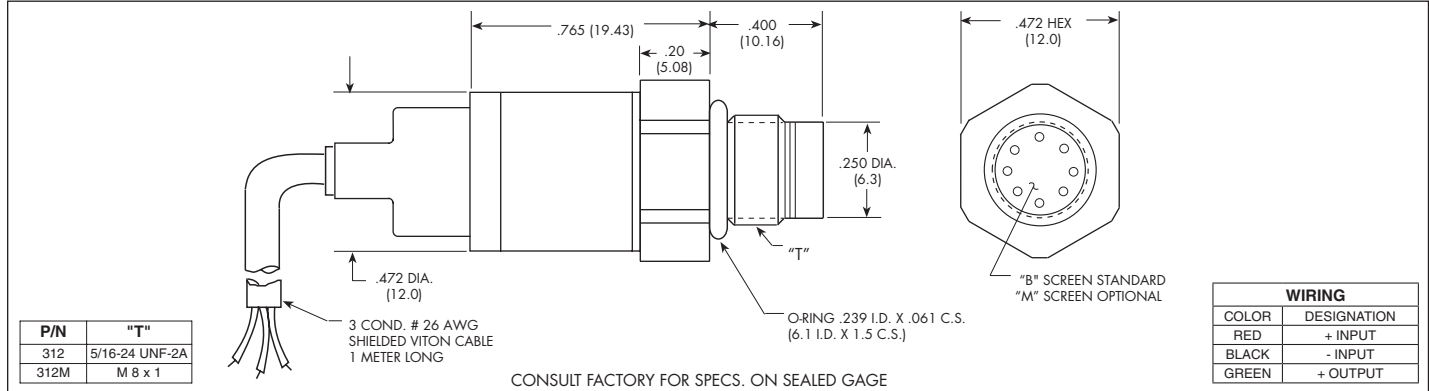

<b>INPUT</b> Pressure Range	1 15	2 29	5 73	10 145	15 218	80 1160	140 2030	210 3045	275 BAR 3988 PSI
Operational Mode	Absolute, Sealed Gage								
Over Pressure	2 Times Rated Pressure < 35 BAR, 1.5 Times Rated Pressure ≥ 35 BAR								
Burst Pressure	3 Times Rated Pressure								
Pressure Media	Any Liquid or Gas Compatible With 15-5 PH or 316 SS								
Rated Electrical Excitation	28 ± 4 VDC (A)			12 ± 4 VDC (B - F)					
Maximum Electrical Current	25 mA (Max.)								
<b>OUTPUT</b> Output Impedance	200 Ohms (Typ.)								
Full Scale Reading (X)	4.5V ± 1.5% (A)	4.5V ± 1.5% (B)	4.5V ± 1% (C)	4.9V ± 1.5% (D)	4.75V ± 1% (E)	4.7V ± 1% (F)			
Bandwidth (-3dB)	DC to 5 KHz								
Residual Unbalance (X)	500 ± 75 mV (A)	500 ± 75 mV (B)	300 ± 45 mV (C)	300 ± 75 mV (D)	300 ± 50 mV (E)	300 ± 50 mV (F)			
Combined Non-Linearity, Hysteresis and Repeatability	± 0.1% FSO BFSL (Typ.), ± 0.25% FSO (Max.)								
Resolution	Infinitesimal								
Acceleration Sensitivity % FS/g Perpendicular Transverse	6.5x10 <sup>-4</sup> 1.0x10 <sup>-4</sup>	4.2x10 <sup>-4</sup> 6.0x10 <sup>-5</sup>	2.3x10 <sup>-4</sup> 3.0x10 <sup>-5</sup>	1.4x10 <sup>-4</sup> 2.0x10 <sup>-5</sup>	1.1x10 <sup>-4</sup> 1.0x10 <sup>-5</sup>	3.6x10 <sup>-5</sup> 4.0x10 <sup>-6</sup>	2.5x10 <sup>-5</sup> 2.7x10 <sup>-6</sup>	1.9x10 <sup>-5</sup> 2.0x10 <sup>-6</sup>	1.6x10 <sup>-5</sup> 2.4x10 <sup>-6</sup>
Insulation Resistance	> 100 Megohm Min. @ 50 VDC								
<b>ENVIRONMENTAL</b> Operating Temperature Range	-65°F to +365°F (-55°C to +185°C)								
Compensated Temperature Range	+68°F to +350°F (+20°C to +175°C) Other Ranges Quoted on Request								
Total Error Band (Excluding End Points)	± 2% FS/212°F ≤ 217.5 PSI (15 BAR), ± 1% FS/212°F ≥ 217.5 PSI (15 BAR)								
Linear Vibration	100g Peak, Sine up to 5000 Hz								
Altitude	-150 ft. to +70,000 ft. Will Not Damage Sensor								
Humidity	100% Relative Humidity								
Mechanical Shock	100g half Sine Wave 11 msec. Duration								
<b>PHYSICAL</b> Electrical Connection	3 Conductor 26 AWG Viton Cable 1 Meter Long								
Weight	15 Grams (Max.) Excluding Cable								
Pressure Sensing Principle	Fully Active Four Arm Wheatstone Bridge Dielectrically Isolated Silicon on Silicon								
Mounting Torque	75 Inch-Pounds (Max.)								

(X) Denotes FSR and Residual Unbalance Options (B), (C), (D), (E) or (F).  
 Note: Custom pressure ranges and mechanical specifications available. Dimensions are in inches and millimeters. All dimensions nominal. (F)  
 Continuous development and refinement of our products may result in specification changes without notice - all dimensions nominal. (F)  
 SUNSTAR 传感与控制 <http://www.sensor-ic.com/> TEL:0755-83376549 FAX:0755-83376182E-MAIL: szss20@163.com  
 KULITE SEMICONDUCTOR PRODUCTS, INC. • One Willow Tree Road • Leonia, New Jersey 07605 • Tel: 201 461-0900 • Fax: 201 461-0990 • <http://www.kulite.com>