



**RUGGEDIZED AUTOMOTIVE IS®  
PRESSURE TRANSDUCERS**

**XTL-HA142C-190 (M) SERIES**

- Easy Installation With Integral Connector
- High Natural Frequency
- 10-32 UNF or M 5 x .8 Thread
- Wide Temperature Range
- Compatible With Most Automotive Fluids
- High Accuracy
- Intrinsically Safe Leadless Technology Applications Available (i.e. IS-XTL-HA142C-190)

**HIGH  
ACCURACY**

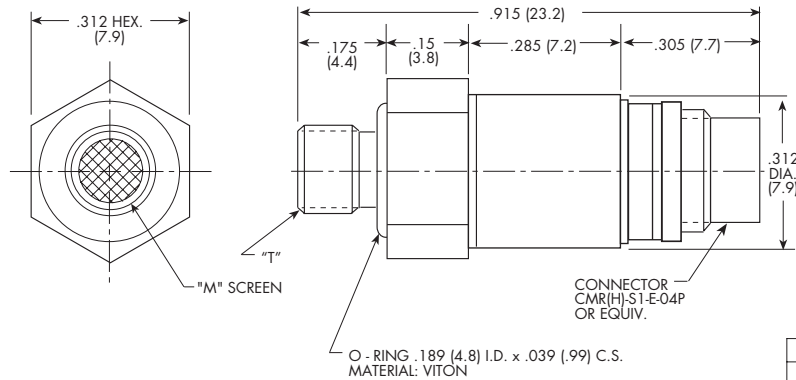

PIN	FUNCTION
1	+ INPUT
2	- OUTPUT
3	- INPUT
4	+ OUTPUT

P/N	"T"
190	10-32 UNF-2A
190M	M 5 x .8

CONSULT FACTORY FOR SPECS. ON SEALED GAGE

<b>INPUT</b> Pressure Range	3.5 50	7 100	17 250	35 500	70 1000	140 2000	210 BAR 3000 PSI
Operational Mode	Absolute, Sealed Gage						
Over Pressure	2 Times Rated Pressure to a Maximum of 4500 PSI (315 BAR)						
Burst Pressure	3 Times Rated Pressure to a Maximum of 4500 PSI (315 BAR)						
Pressure Media	All Nonconductive, Noncorrosive Liquids or Gases (Most Conductive Liquids and Gases - Please Consult Factory)						
Rated Electrical Excitation	10 VDC						
Maximum Electrical Excitation	15 VDC						
Input Impedance	1000 Ohms (Min.), 5000 Ohms (Max.)						
<b>OUTPUT</b> Output Impedance	1000 Ohms ± 500 Ohms						
Full Scale Output (FSO)	100 mV ± 10mV						
Residual Unbalance	± 5 mV (Typ.)						
Combined Non-Linearity, Hysteresis and Repeatability	± 0.1% FSO BFSL (Typ.), ± 0.3% FSO (Max.)						
Resolution	Infinitesimal						
Natural Frequency (KHz) (Typ.)	Greater Than 175 KHz						
Acceleration Sensitivity % FS/g Perpendicular	3.0x10 <sup>-4</sup>	1.5x10 <sup>-4</sup>	1.0x10 <sup>-4</sup>	6.0x10 <sup>-5</sup>	4.5x10 <sup>-5</sup>	2.0x10 <sup>-5</sup>	2.0x10 <sup>-5</sup>
Transverse	4.0x10 <sup>-5</sup>	2.0x10 <sup>-5</sup>	9.0x10 <sup>-6</sup>	6.0x10 <sup>-6</sup>	3.0x10 <sup>-6</sup>	3.0x10 <sup>-6</sup>	2.0x10 <sup>-6</sup>
Insulation Resistance	100 Megohm Min. @ 50 VDC						
<b>ENVIRONMENTAL</b> Operating Temperature Range	-65°F to +400°F (-55°C to +204°C)						
Compensated Temperature Range	-40°F to +350°F (-40°C to +175°C)						
Total Error Band Over Compensated Temperature Range, BFSL	± 2% FS, Includes Thermal Sensitivity Shift, Thermal Zero Shift And Static Error Band Over Compensated Temperature Range						
Linear Vibration	100g Peak, Sine Up to 5000 Hz						
Humidity	100% Relative Humidity						
Mechanical Shock	100g half Sine Wave 11 msec. Duration						
<b>PHYSICAL</b> Electrical Connection	Connector CMR(H)-S1-E-04P or Equivalent (Mating Connector Available Upon Request)						
Weight	5 Grams (Nom.) Excluding Cable						
Pressure Sensing Principle	Fully Active Four Arm Wheatstone Bridge Dielectrically Isolated Silicon on Silicon Patented Leadless Technology						
Mounting Torque	15 Inch-Pounds						

Note: Custom pressure ranges, accuracies and mechanical configurations available. Dimensions are in inches. Dimensions in parenthesis are in millimeters. Continuous development and refinement of our products may result in specification changes without notice - all dimensions nominal. (D)