

XFC205R Miniature Load Cell



- 0-2 to 0-200N [0-0.4 to 0-40 Lbf]
- Compression
- High Stiffness
- Integrated Spherical Load Button
- Easy Installation with Threaded M5 Male Base
- For Static and Dynamic Applications
- Important Overload Capacity

DESCRIPTION

The miniature size and light weight of the XFC205R facilitates testing where these conditions are necessary. Unlike sensors with flat force application surfaces, the XFC205R incorporates a spherical load button resulting in more precise measurements. Its high stiffness, for the size and measurement ranges, allows measurements in dynamic applications. A strain relief spring strengthens the cable output. The sensing element is fitted with a fully temperature compensated Wheatstone bridge equipped with high stability micro-machined silicon strain gages. With a threaded M5 male base, the XFC205-R is easily installed in industrial or OEM applications.

With many years of experience as a designer and manufacturer of sensors, Measurement Specialties, Inc. often work with customers to design or customize sensors for specific uses and testing environments.

To meet your needs we also offer complete turnkey systems. The matched components (sensor, power, amplifier and digital display) are formatted, calibrated and ready for immediate use.

FEATURES

- Easy Installation with Threaded M5 Male Base
- Other thread and design on request
- Integrated Spherical Load Button
- High Stability
- Higher IP rating on request

APPLICATIONS

- Process control on miniature equipment
- Press-fit machinery
- Robotics and effectors
- Laboratories
- Fibre Optical component assembly

STANDARD RANGES

F.S. Ranges in N	2 to 5	10 to 20 to 50	100 to 200
F.S. Ranges in Lbf	0.4 to 1	2 to 4 to 10	20 to 40
Stiffness in N/m	3.7×10^5 To 1.4×10^6	6.1×10^6 To 6.6×10^7	1.1×10^8 To 3.2×10^8
Stiffness in Lbf/ft	2.5×10^4 To 9.6×10^4	4.2×10^5 To 4.5×10^5	7.5×10^6 To 2.2×10^7
Materials	Aluminium		Stainless Steel

XFC205R Miniature Load Cell

PERFORMANCE SPECIFICATIONS

Ambient Temperature: 20±1° C (unless otherwise specified)

PARAMETERS	
Operating Temperature Range (OTR)	-40 to 120 °C [- 40 to 248 °F]
Compensated Temperature Range (CTR)	0 to 60 °C [32 to 140 °F]
Zero Shift in CTR	<2% F.S. /60 °C [108 °F]
Sensitivity Shift in CTR	<2% of reading / 60 °C [108 °F]
Range (F.S.)	0-2 N to 0-200 N [0-0.4 Lbf to 0-40 Lbf]
Over-Range	
Without Damage	3 to 4 x F.S.
Without Destruction	5 to 6 x F.S.
Accuracy	
Linearity	≤±0.5% F.S.
Hysteresis	≤±0.5% F.S.

Electrical Characteristics

Model	XFC205R
Supply Outage	10Vdc
F.S. Output	100 mV
Zero Offset	<±10 mV
Input Impedance/Consumption	1000 to 3000Ω
Output Impedance	500 to 1000Ω
Insulation under 50Vdc	≥100MΩ

Notes

1. Electrical Termination: Cable: Shielded cable with 4 Teflon wires (AWG36), standard length 2 m [6.5 ft] with strain relief spring
2. Material: Body in stainless steel or aluminum alloy
3. Protection Index: IP50

XFC205R Miniature Load Cell

DIMENSIONS & WIRING SCHEMATIC (IN METRIC AND IMPERIAL)

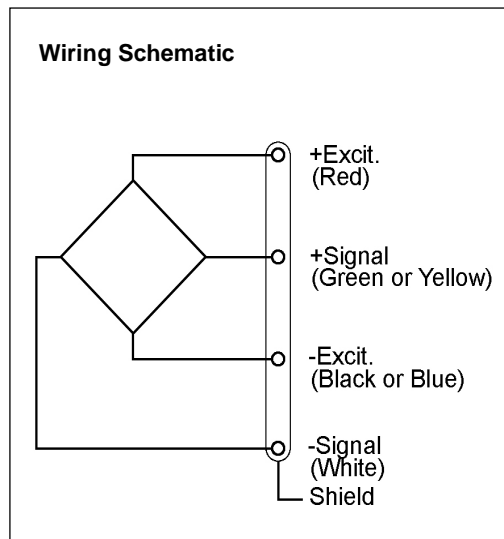
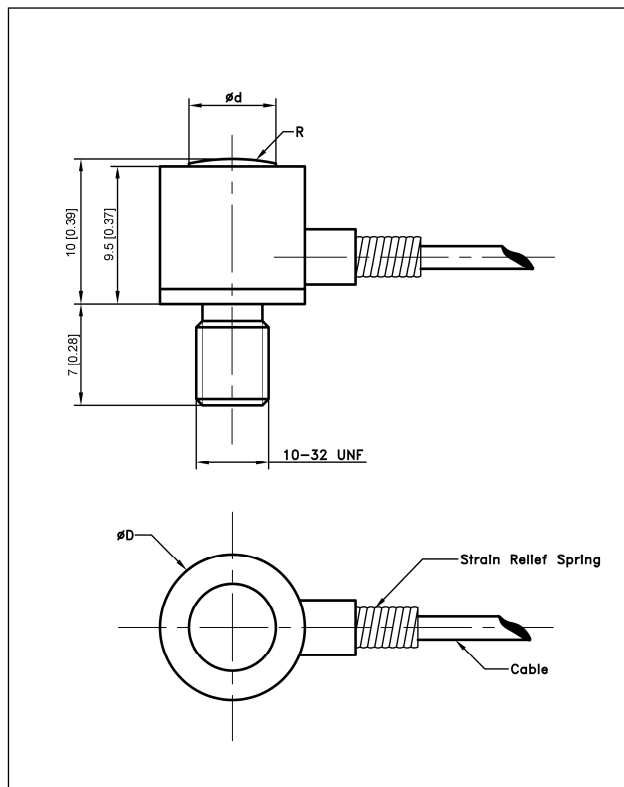

Dimensions in mm [inch]

Mechanical Characteristics

F.S. Ranges in N [in Lbf]	2 - 5 [0.4 - 1]	10 - 20 - 50 [2 - 4 - 10]	100 - 200 [20 - 40]
Diameter D	10 [0.39]		
Diameter d	3 [0.12]		5 [0.20]
Material	Aluminium	Aluminium	Stainless steel
Stiffness in Lbf/ft	2.5×10^4 to 9.6×10^4	4.2×10^5 to 4.5×10^6	7.5×10^6 to 2.2×10^7
Over-range w/o damage	x4	x4	x3
Over-range w/o destruction	x6	x6	x6

XFC205R Miniature Load Cell

OPTIONS

ET1 : CTR -20 to 100 ° C [-4 to 212 ° F]
ET2 : CTR -40 to 120 ° C [-40 to 248 ° F]
ET3 : CTR -40 to 150 ° C [-40 to 302 ° F] OTR=CTR (s tainless steel only)
HA : Accuracy (CNL&H) $\leq \pm 0.05\%$ F.S.
LC"x" : Additional cable length to standard length (in m) (Note : "X" = Custom value)
* Order Flat Force application surface with reference XFC205.

ORDERING INFO

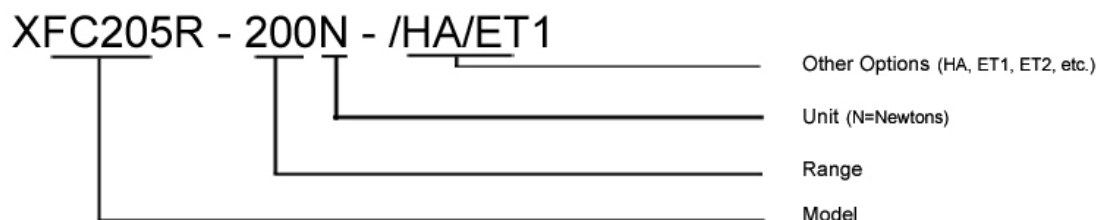

The information in this sheet has been carefully reviewed and is believed to be accurate; however, no responsibility is assumed for inaccuracies. Furthermore, this information does not convey to the purchaser of such devices any license under the patent rights to the manufacturer. Measurement Specialties, Inc. reserves the right to make changes without further notice to any product herein. Measurement Specialties, Inc. makes no warranty, representation or guarantee regarding the suitability of its product for any particular purpose, nor does Measurement Specialties, Inc. assume any liability arising out of the application or use of any product or circuit and specifically disclaims any and all liability, including without limitation consequential or incidental damages. Typical parameters can and do vary in different applications. All operating parameters must be validated for each customer application by customer's technical experts. Measurement Specialties, Inc. does not convey any license under its patent rights nor the rights of others.