



NEMOTO & CO., LTD SENSOR DIVISION

NAP-55A Catalytic Sensor for Methane / Natural Gas

The NAP-55A Gas Sensor is a low-cost Catalytic Flammable Gas Sensor designed for the detection and measurement of Methane or Natural Gas in the range 0-50% LEL. Developed primarily for use in Residential Gas Detectors, the NAP-55A has also been found to be useful in a wide variety of applications where reliable detection of gas leaks and other gas hazards is required at low cost.



The NAP-55A uses the superior catalytic “pellistor” detection principle often used in high quality Industrial Gas Detectors. It hence has many benefits over other low cost gas sensor types:

- **Monitors flammability directly**
- **Unaffected by humidity**
- **Very low long term drift**
- **Excellent resistance to catalytic poisons**
- **Single header design for ease of use**
- **Superb temperature stability**
- **Resistant to shocks and vibration**
- **Linear output to 50% LEL methane**

Specifications NAP-55A:

Detectable gas:	Methane and Natural gas
Detection range:	0-50% LEL (0-2.5% V/V)
Bridge Voltage	2.5V +/- 0.25V
Bridge Current	170mA +/- 10mA
Sensitivity to Gas*:	37-53mV for 1% CH ₄
Bridge zero offset*:	0 +/- 35mV

*in Nemoto's recommended bridge circuit

Repeatability:	
Zero:	+/- 0.5mV
Signal:	+/- 0.5mV
Expected lifetime:	5 years

Long Term Drift: Zero:	<+/- 2mV/year
Span:	<+/- 2%/month
Linearity:	Effectively Linear to 50% LEL
Response time(T ₉₀):	<10 seconds

Note: In practice the response time of a gas sensor is very much dependent on the mounting arrangement within an instrument.

Environmental Conditions:

Operating temperature:	-10°C to +50°C
Humidity range:	0-95% RH
Pressure:	0.9 – 1.1 atm
Storage Temperature:	-20°C to +50°C
Recommended Storage Time:	6 months

More detailed information, covering all aspects of performance, including long term stability, repeatability, environmental tolerances to humidity, temperature, wind, shock, cross sensitivity to other gases, recommended circuitry, handling requirements and an explanation of the operating principles of the NAP-55A, please consult the Handling Manual for the device, available on request.

NAP-55A datasheet Oct 2008

Nemoto has a policy of continuous development and improvement of its products. As such the specification for the device outlined in the data sheet may be changed without notice.

Nemoto (Europe) B.V.
Strawinskyiaan 647,1077 XX Amsterdam, Netherlands
TEL: +31 20 670 3858
FAX: +31 20 670 2709

URL: <http://www.nemoto.co.jp>

Sensor : NAP-55A

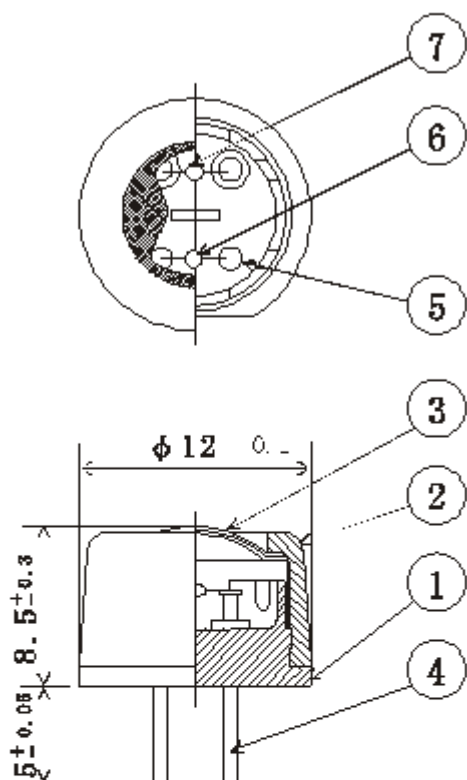

Detector mark

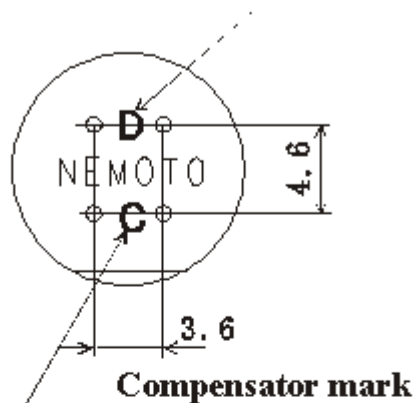

Compensator mark

Bottom view

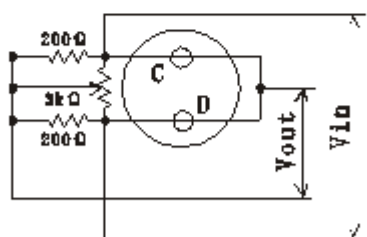

Measuring Circuit

No.	Parts names	Material	Remarks
1	Mount	Nylon 66	Glass 20% contained
2	Cap	Nylon 66	Glass 20% contained
3	Mesh	SUS 316	#100, Doublemesh
4	Pin	Pure Ni	$\phi 0.8$
5	Coil	PPT	$\phi 30\mu\text{m}$
6	Compensator		Nemoto & Co., Ltd
7	Detector		Nemoto & Co., Ltd

APPROVED	CHECKED	DESIGNED	DRAWN	MATERIAL	QTY	SCALE
TITLE				DATE	DRG. NO.	
NAP-55A				DEC. 25, 1993	G-01-04-143	
NEOTO & CO., LTD						