

**Nemoto Sensor
Engineering Co., Ltd**

Nemoto (Europe) B.V.
Burgemeester
Haspelslaan 53
1181NB, Amstelveen
The Netherlands
Tel +31 20 670 3858
Fax +31 20 670 2709
www.nemoto.eu

Technical Information

(Catalytic Type Gas Sensor)

Model NCP-300

(Matched Pair Type)

For Industrial Applications



〒168-0072 4-10-9, Takaido-higashi, Suginami-ku, Tokyo

Nemoto Sensor Engineering Co., Ltd.

TEL. 81-3-3333-2760

FAX. 81-3-3333-7344

E-mail sensor2@nemoto.co.jp

URL <http://www.nemoto.co.jp/>



1. General

Catalytic type gas sensor NCP series were developed for industrial applications, and NCP-300 is a matched pair type gas sensor for general combustible gases. Shape, supply voltage and current are compatible with other sensors, however reliability, repeatability, stability and responsibility are quite superior to others, additionally the durability in strict circumstance are quite excellent. Features and typical applications are as follows.

2. Features and applications

1) Features

- Good stability
- Excellent repeatability and detection accuracy
- Good linearity against gas concentration
- Quick response
- Down-sizing for design flexibility of gas alarm or detector

2) Applications

- Fixed type gas alarm or detector for general combustible gases
- Gas densitometer

3. Ratings

- | | |
|--|--|
| 1) Supply voltage to sensor | AC 2.0 +/- 0.1V(50—60Hz)
DC 2.0 +/- 0.1V |
| 2) Current (when 2.0V is supplied) | AC 300 +/- 20mA(50—60Hz)
DC 300 +/- 20mA |
| 3) Ambient temperature and humidity in operation | Temperature -20 - +60 degree C
Humidity Less than 95%RH
(without dew condensation) |
| 4) Ambient temperature and humidity in storage | Temperature -30 - +70 degree C
Humidity Less than 99%RH
(without dew condensation) |
| 5) Detection range | 0 – 100%LEL
(Except acetylene) |
-
- | | |
|-----------------------------|--|
| 4. Specification | |
| 1) Zero offset value in air | 0 +/- 25mV
(without trimming resistor) |
| 2) Minimum sensitivity | 16mV/1% of methane |
| 3) Response time | Less than 8 sec. at T90
Less than 3 sec. at T50 |
| 4) Linearity | Effectively linear to 60%LEL |
| 5) Detection accuracy | +/- 1%LEL |



- | | |
|----------------------|-------------------------|
| 6) Span drift | Less than 1%LEL/month |
| 7) Zero offset drift | Less than 0.5%LEL/month |
| 8) Warranty period | 24 months |

5. Appearance and dimension

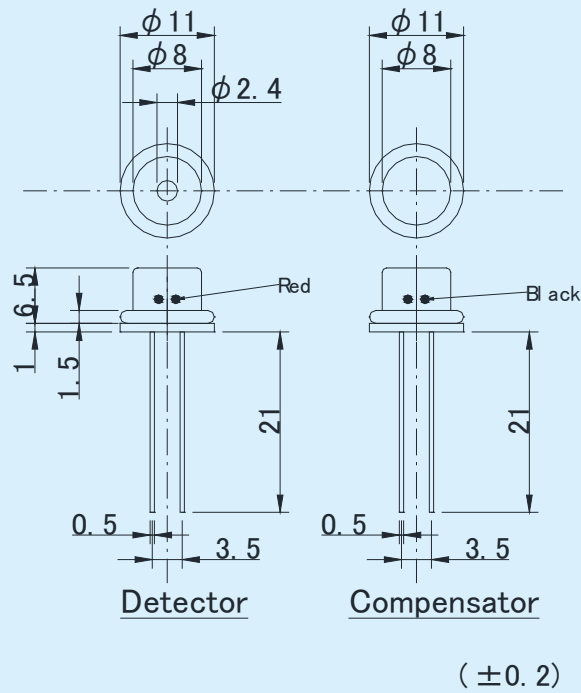

Fig. 1 : Appearance and dimensions

Remarks)

O-rings are attached on both as shown in the above.

6. Measuring circuit diagram

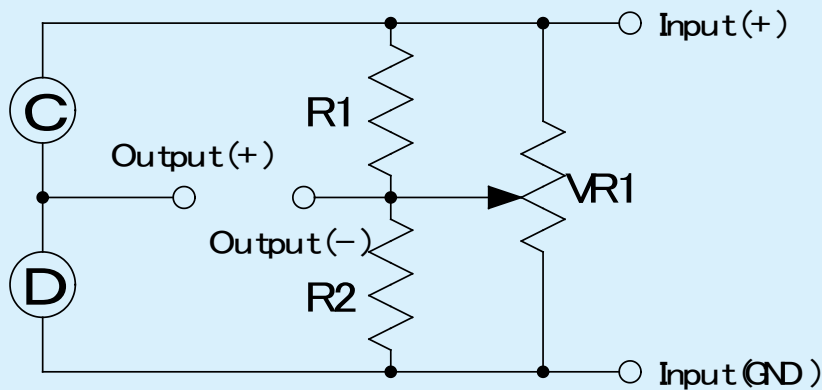

Fig. 2 : Recommended circuit diagram
(R1, R2 : 200ohm, VR1 : 3Kohm)



7. Gas sensitivity characteristics

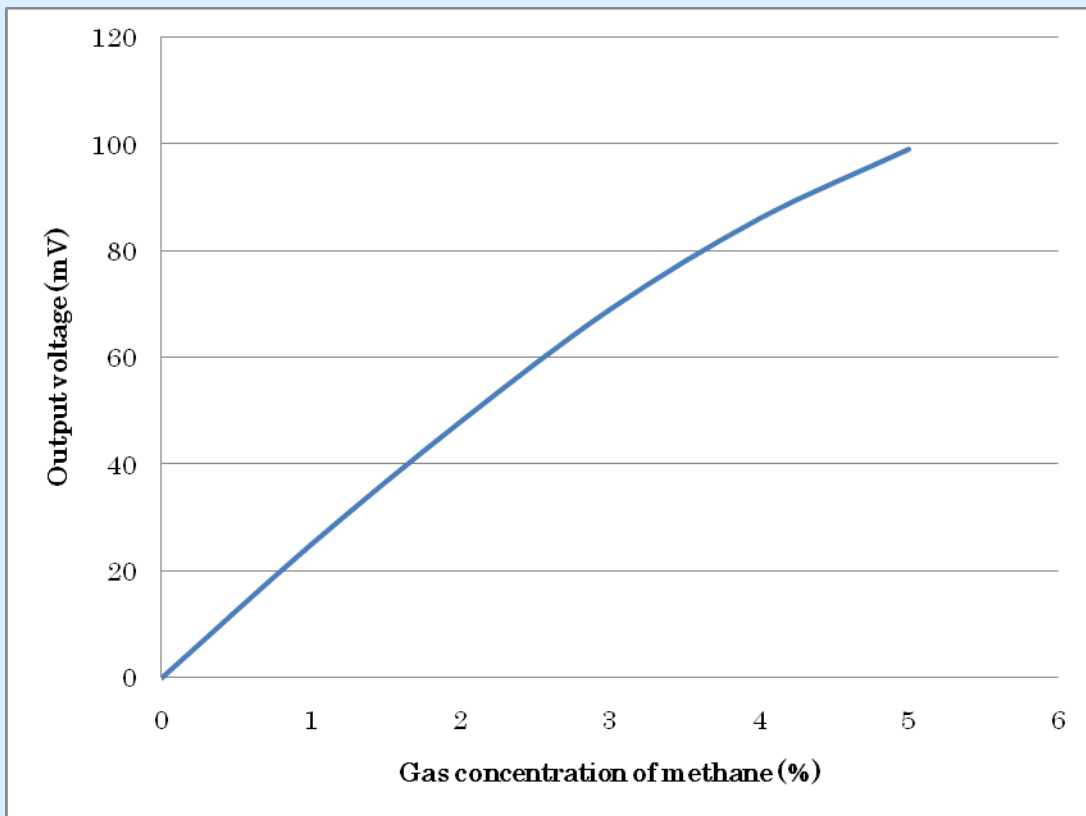

Fig. 3 : Gas sensitivity characteristics

8. Temperature dependence at 60%RH

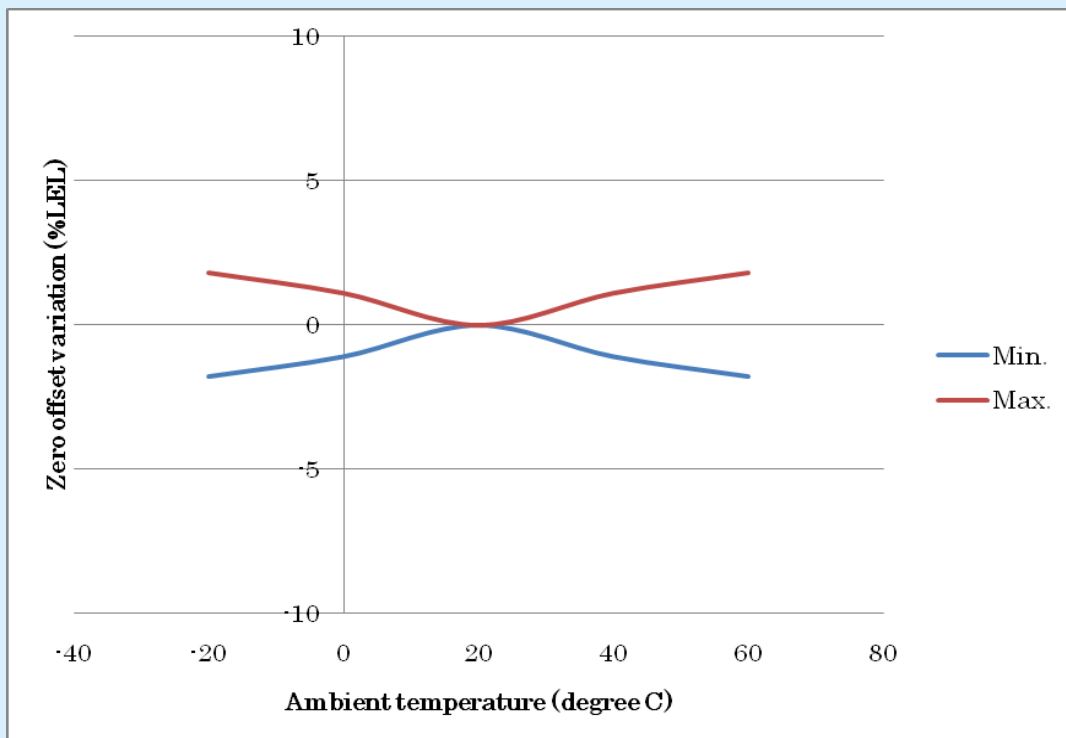

Fig. 4 : Temperature dependence of zero offset

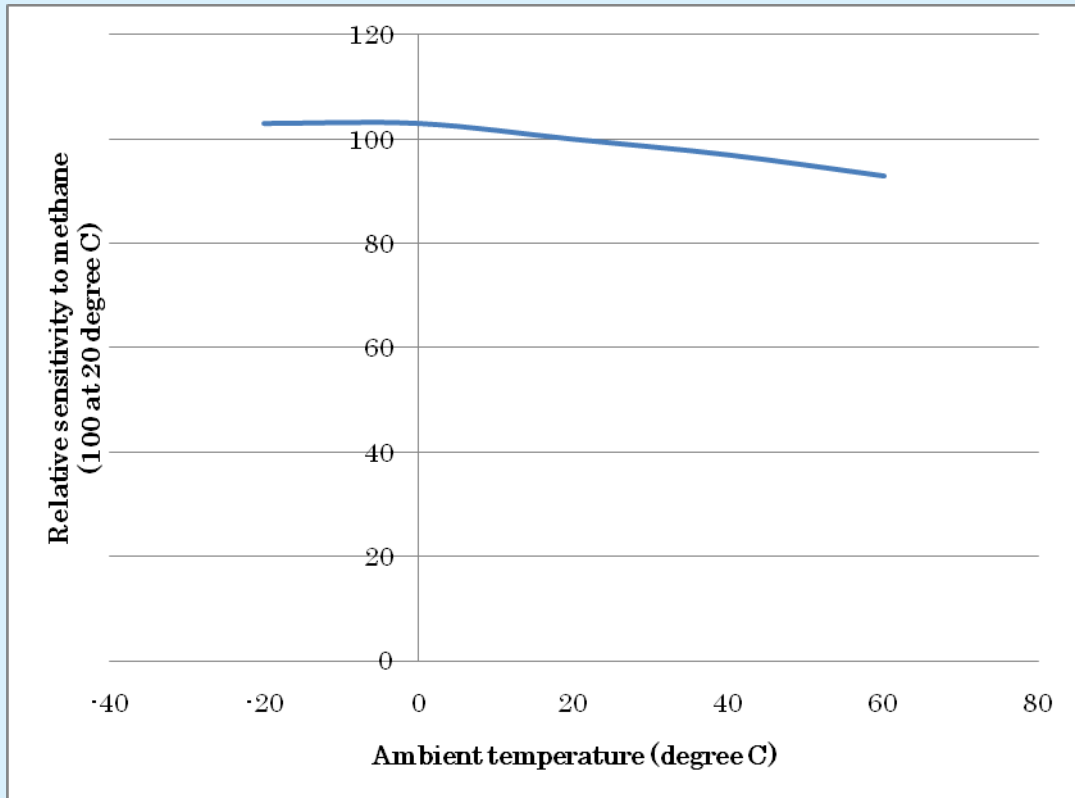

Fig. 5 : Temperature dependence of relative sensitivity to methane

9. Humidity dependence

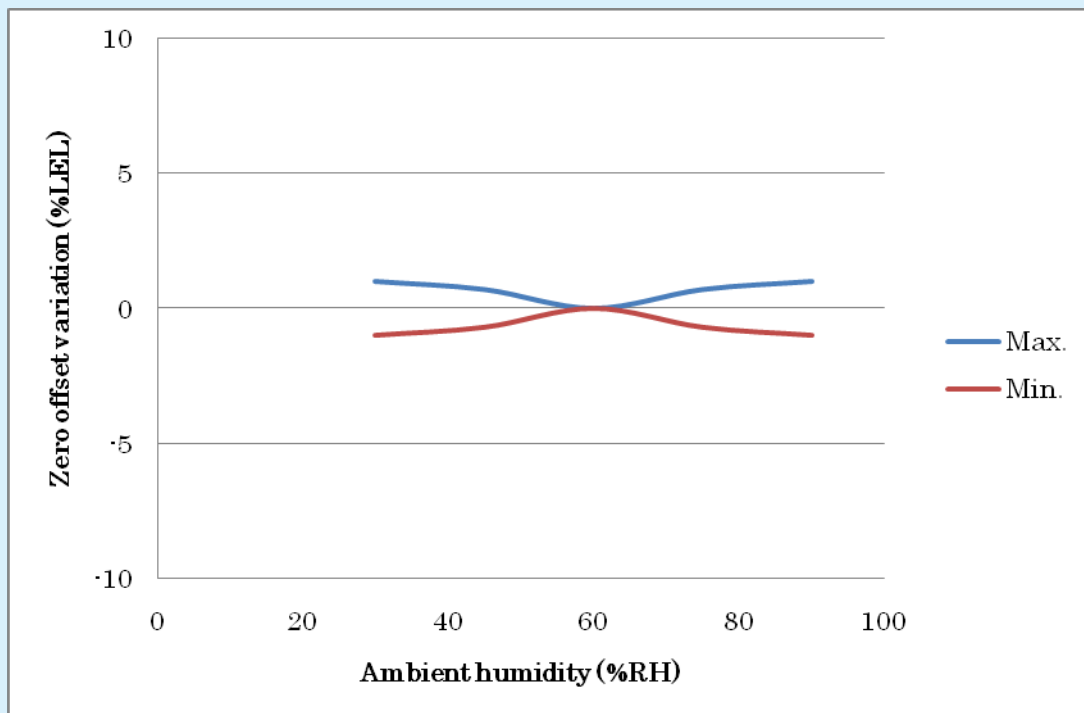

Fig. 6 : Humidity dependence of zero offset (at 25 degree C)

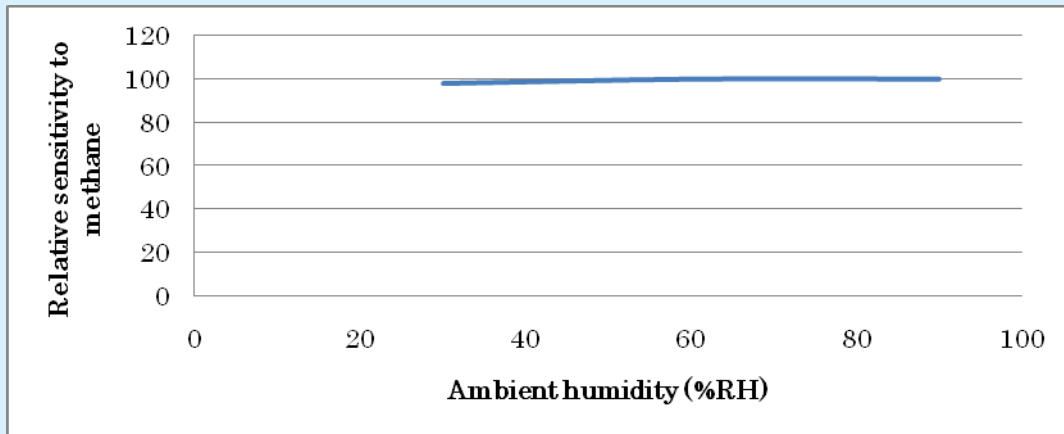

Fig.7 : Humidity dependence of relative sensitivity to methane

10. Long term stability

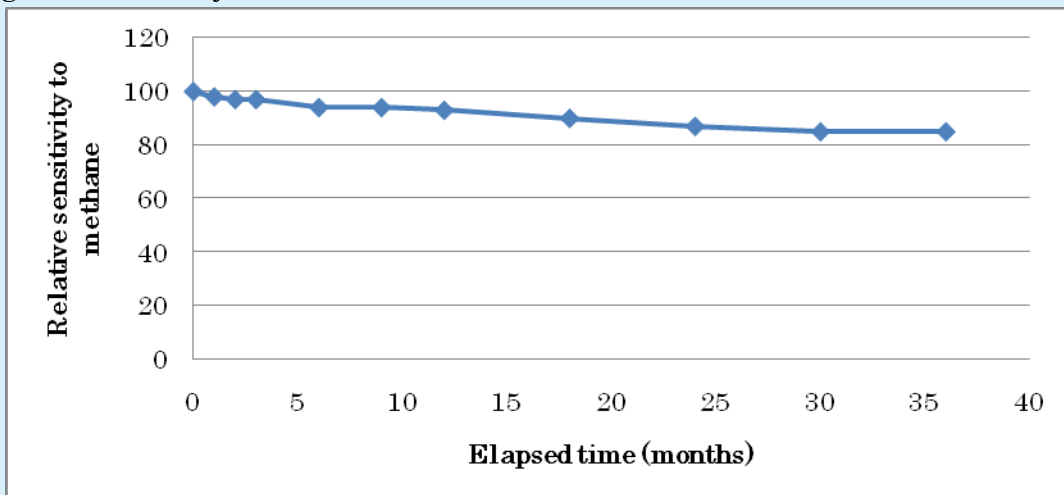

Fig. 8 : Long term stability of relative sensitivity to methane

11. Sensitivity distribution

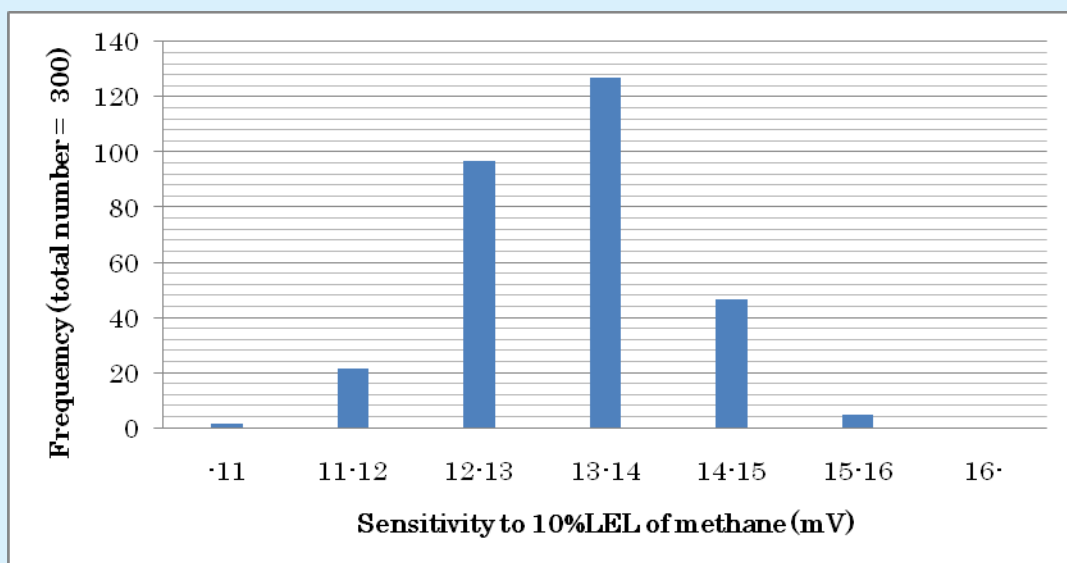

Fig. 9 : Sensitivity distribution



12. Relative sensitivity

(In case that sensitivity to methane is 100.)

	Gas/Vapor	Chemical formula	LEL (%)	Relative sensitivity
Std.	Methane	CH₄	5.0	100
1	Acetic acid	CH ₃ COOH	5.4	40
2	Acetone	(CH ₃) ₂ CO	2.6	60
3	Butyl acetate	C ₄ H ₉ COOH	1.4	40
4	Cyclo-hexane	C ₆ H ₁₂	1.3	45
5	Cyclo-pentane	C ₅ H ₁₀	1.4	50
6	Dioxane	(CH ₂) ₄ O ₂	2.0	55
7	Ethane	C ₂ H ₆	3.0	85
8	Ethanol	C ₂ H ₅ OH	3.3	70
9	Ethyl acetate	C ₂ H ₅ COOH	2.2	55
10	Ethylene	C ₂ H ₄	2.7	85
11	Hydrogen	H ₂	4.0	105
12	Iso-butane	C ₄ H ₁₀	1.8	80
13	Iso-butyl alcohol	CH ₃ -C ₃ H ₆ COOH	1.7	40
14	Iso-octane	C ₈ H ₁₈	0.95	60
15	Iso-pentane	C ₅ H ₁₂	1.4	75
16	Iso-propanol	CH ₃ -C ₂ H ₄ COOH	2.2	70
17	Methanol	CH ₃ OH	6.7	105
18	Methyl ethyl ketone	CH ₃ -CO-C ₂ H ₅	1.9	70
19	N-butane	C ₄ H ₁₀	1.8	80
20	N-heptane	C ₇ H ₁₆	1.05	65
21	N-hexane	C ₆ H ₁₄	1.2	70
22	N-pentane	C ₅ H ₁₂	1.4	75
23	N-propanol	C ₃ H ₇ OH	2.2	70
24	Propane	C ₃ H ₈	2.1	85
25	Stylene	C ₆ H ₅ CH=CH ₂	1.1	40
26	Toluene	C ₆ H ₅ CH ₃	1.2	55
27	Ammonia	NH ₃	15.0	120
28	Propylene	CH ₃ -CH=CH ₂	2.4	75
29	Carbon monoxide	CO	12.5	100
30	Xylene	C ₆ H ₄ (CH ₃) ₂	1.1	45

Remarks:

If other data are required, please contact us since sensitivity of many combustible gases except bad smell, dangerous, poisonous and high boiling temperature materials over 120 degree C are available for investigations.



13. Durability

1) Exposure in hydrogen sulfide

Test conditions

Sensors were exposed in 50%LEL of methane and 25ppm of hydrogen sulfide for 1hr. at normal temperature and humidity.

No.	Before test (mV)		After test (mV)	
	Zero offset	Relative sensitivity to CH4	Zero offset	Relative sensitivity to CH4
1	3.8	100	4.5	98
2	19.4	100	20.8	98
3	20.2	100	22.1	98
4	-11.1	100	-10.7	99
5	22.9	100	24.0	100

2) Exposure in HMDS

Test conditions

Sensors were exposed in 50%LEL of methane and 10ppm of HMDS for 1hr. at normal temperature and humidity.

No.	Before test (mV)		After test (mV)	
	Zero offset	Relative sensitivity to CH4	Zero offset	Relative sensitivity to CH4
1	14.5	100	14.8	93
2	11.9	100	13.2	87
3	10.2	100	11.1	89
4	-4.4	100	-3.7	90
5	-23.1	100	-22.6	81

3) Exposure in high concentration of methane

Test conditions

Sensors were exposed in 8% (160%LEL) of methane at normal temperature and humidity for 1hr.

No.	Before test (mV)		After test (mV)	
	Zero offset	Relative sensitivity to CH4	Zero offset	Relative sensitivity to CH4
1	13.9	100	15.1	98
2	9.6	100	10.3	103
3	9.4	100	10.9	100
4	-11.0	100	-10.4	103
5	-24.3	100	-22.8	101



4) Drop test

Test conditions

Sensors were dropped from the height of 30cm onto the wood board of 3cm thickness with free fall by 3 times.

No.	Before test (mV)		After test (mV)	
	Zero offset	Relative sensitivity to CH4	Zero offset	Relative sensitivity to CH4
1	21.6	100	23.1	100
2	10.4	100	10.8	99
3	-22.1	100	-21.5	98
4	-17.8	100	-17.0	102
5	1.6	100	1.8	102

5) Vibration test

Test conditions

Vibration which is 10Hz with the 4mm of amplitude for 20min. to 3 directions of X, Y and Z was added to sensors at normal temperature and humidity.

No.	Before test (mV)		After test (mV)	
	Zero offset	Relative sensitivity to CH4	Zero offset	Relative sensitivity to CH4
1	7.5	100	7.7	101
2	13.2	100	12.8	101
3	0.8	100	0.4	100
4	-9.3	100	-9.3	104
5	24.7	100	24.4	102

6) Storage in high temperature and humidity

Test conditions

Sensors were stored in 60 degree C, 90%RH for 1000hrs. without being energized.

No.	Before test (mV)		After test (mV)	
	Zero offset	Relative sensitivity to CH4	Zero offset	Relative sensitivity to CH4
1	10.4	100	10.9	100
2	7.1	100	8.3	100
3	11.8	100	12.0	102
4	22.1	100	22.0	100
5	22.7	100	23.5	102



7) Operation in high temperature and humidity

Test conditions

Sensors were energized in 60 degree C, 90%RH for 1000hrs.

No.	Before test (mV)		After test (mV)	
	Zero offset	Relative sensitivity to CH4	Zero offset	Relative sensitivity to CH4
1	1.5	100	1.2	97
2	-13.5	100	-13.0	99
3	-12.2	100	-10.7	99
4	-10.8	100	-10.1	95
5	3.7	100	5.5	94

8) Storage in low temperature

Test conditions

Sensors were stored in -20 degree C for 1000hrs.

No.	Before test (mV)		After test (mV)	
	Zero offset	Relative sensitivity to CH4	Zero offset	Relative sensitivity to CH4
1	4.8	100	5.0	98
2	10.3	100	9.7	100
3	-4.5	100	-4.9	98
4	-3.2	100	-3.1	97
5	-19.8	100	-18.8	97



14. Evaluation method

1. Test equipment

Outline of test equipment is as follows.

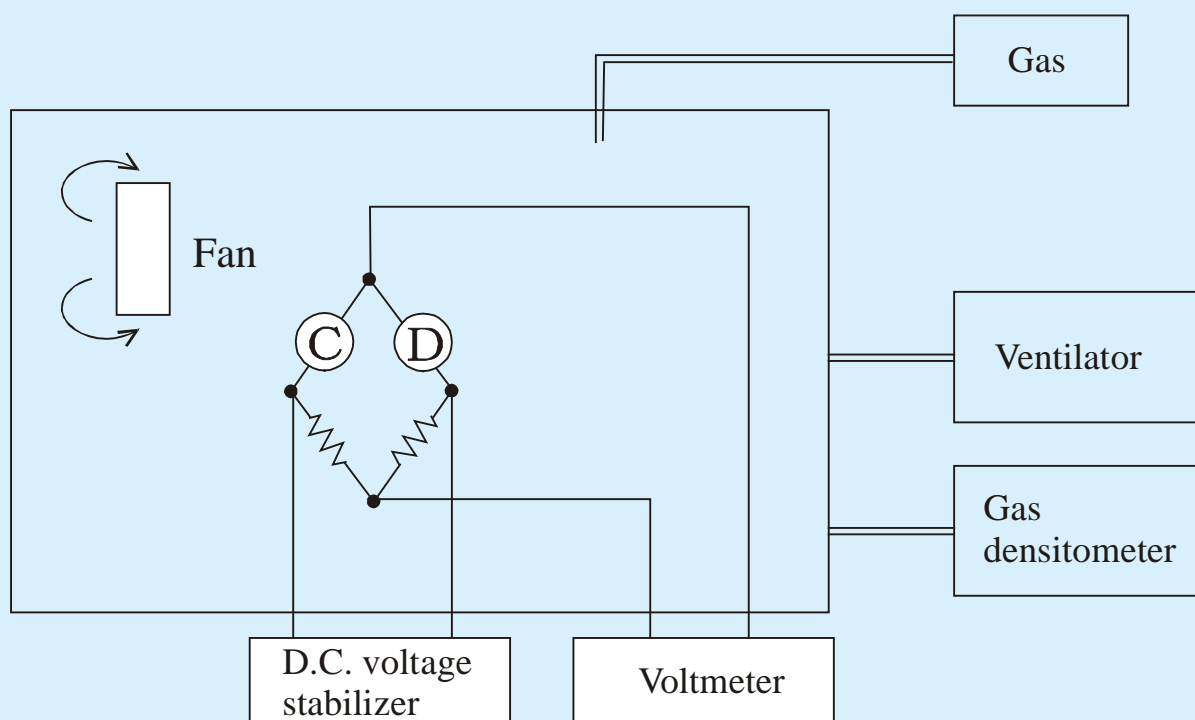

Remarks on equipments)

A) Test chamber

- Material of test chamber is to be inactive like metal, glass or acrylic resin which does not exhale and adsorb gases.
- Volume of test chamber is to be more than 1 liter per 1pc. of sensor.

B) Circumstance

- Clean circumstance is recommended as evaluation area. Dirty circumstance which contains combustible gases like organic solvent vapor is to be avoided.

C) Gas densitometer

- Laser gas densitometer is recommended, but volume method is available simply.

D) Agitation in test chamber

- Air agitation in test chamber is to be conducted carefully in order not to flow air to sensor directly. Air velocity to sensor is to be less than 0.5m/sec.

E) Power supply

- Both of AC power and DC power are available for sensor, however DC power supply is recommended for accurate evaluation.

F) Digital volt meter

- Since the impedance of sensor is fairly low, general digital volt meter having over 100kohm as input impedance is sufficiently available.

G) Ventilation

- Ventilator with ventilation capacity of over 10 times/min. of the volume of test chamber is recommended for the convenient evaluation.

H) Installation position of sensor in test chamber



- When the sensor is installed in test chamber, it should be careful that each sensor is to be in constant position because output signal changes in case that position of sensor changes. If the rough evaluation is carried out, such careful treatment is not necessary.

2. Adjustment of gas concentration

Adjustment of gas concentration is to be conducted by volume method or by using laser gas densitometer. In case of volume method, gas volume to be injected into a chamber is obtained from the calculation formula below described.

$$V(m\ell) = Vi \cdot C \cdot 10^{-6} \frac{273 + Tr}{273 + Tc}$$

V : Gas volume to be injected

Vi : Volume of test chamber ($m\ell$)

Tc : Temperature in test chamber ($^{\circ}C$)

Tr : Room temperature ($^{\circ}C$)

C : Target gas concentration (ppm)

3. Evaluation method

A. Preliminary aging

- Before evaluation of sensor, preliminary aging at rated voltage for over 1 hr. is recommended for accurate evaluation.

B. Measurement

- At first, output voltage in clean air is measured. It should be confirmed that output voltage has to be stable without fluctuation.
- Output voltage is measured around 1min. later after the designated volume of gas is injected into a test chamber.
- Inside of test chamber should be substituted of clean air by ventilator.

4. Notice on handling

- Sensor is to be gently handled without adding shock or dropping.
- Handling in a location which corrosive gases or poisonous gases exist is to be avoided.
- Sensor does not have to be dipped in water.
- Sensor does not have to be disassembled.
- Since sensor does not have an explosion proof structure, it should be assembled in an approved body.

Nemoto Sensor Engineering Co., Ltd.

4-10-9 Takaido-higashi, Suginami-ku, Tokyo 168-0072, Japan

Tel. 81-3-3333-2760, Fax. 81-3-3333-7344

Tech. Inf. No.NCP-300-120918