

Preliminary

PIR0001

PIR Controller IC for LED Lamp Specification

GENERAL DESCRIPTION

The PIR0001 IC is a CMOS chip designed to PIR controller IC for DC LED lamp . It can use PHOTO transistor or CDS application. The chip built-in regulator provides stable power. The chip is equipped with amplifiers, comparator, timer, control circuits, system oscillator, and output timing oscillator. Its PIR sensor detects infrared power variation induced by the motion of a human body and transforms it to a voltage variation. If PIR output voltage variation conforms to the criteria, then the lamp LED is turned on with an adjustable duration.

FEATURES

- Operating voltage 3.6V~5.5V, Built-in regulator 3.0V±0.36V .
- Built-in 16Khz oscillator for system clock.
- Operating current @VBAT=4.5V, no load standby current< 20uA
- Provides **PHOTO** or **CDS** sensor detect environment **Day_time** or **Night_time**.
- Provide turn on delay timer fix 16 sec.
- After power-on have about 1sec stable-time and 16sec warm-up time.
- When lamp turn on change to turn off, then disable PIR 1sec

APPLICATION

- Wide consumer products

BLOCK DIAGRAM

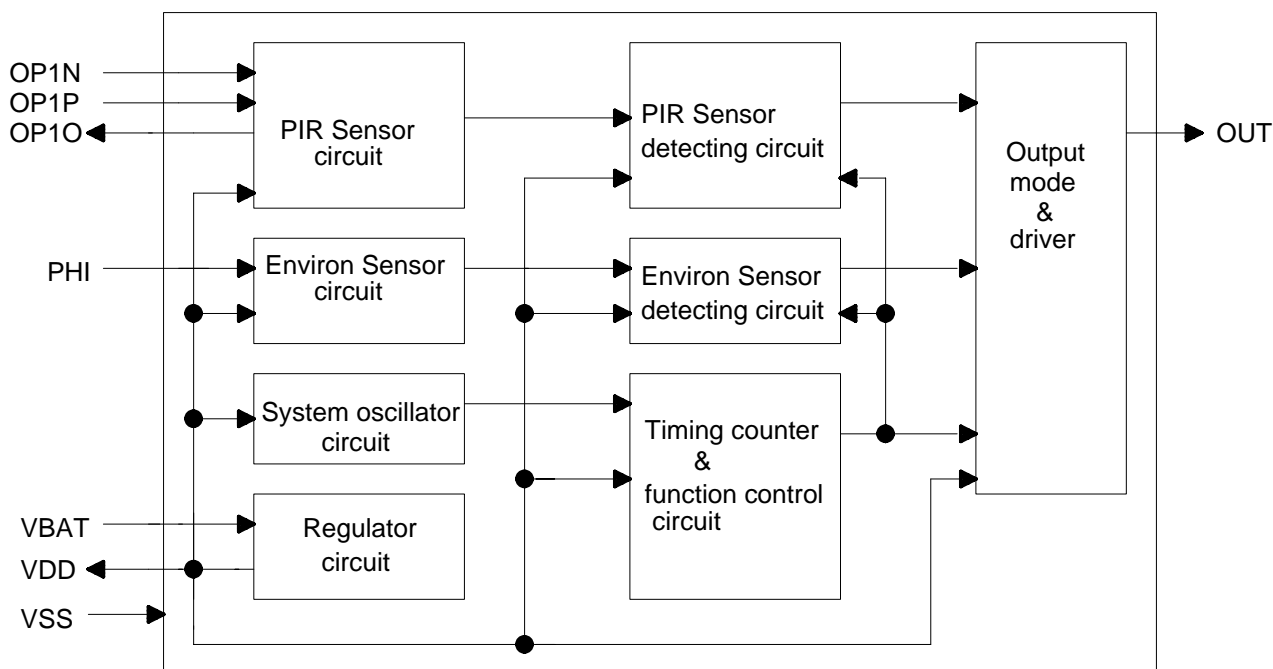

Preliminary

PIR0001

PACKAGE LIST

PIR0001A : DIP 8 pin
 PIR0001B : SOP 8 pin

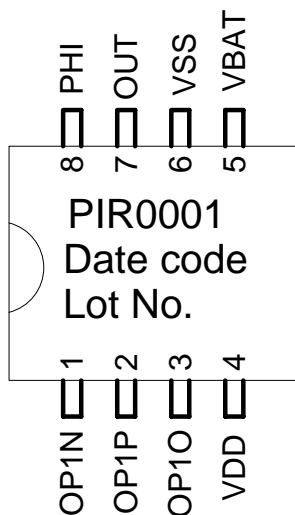

PAD DESCRIPTION

| Pad No. | Pad Name | I/O Type | Pad Description |
|---------|----------|----------|---|
| 1 | OP1N | I | PIR first OP AMP(-) input pin |
| 2 | OP1P | I | PIR first OP AMP(+), 0.4VDD voltage input pin |
| 3 | OP1O | O | PIR first OP AMP (out) output pin |
| 4 | VDD | O | Built-in regulator output pin |
| 5 | VBAT | P | DC 3.6V~5.5V power pin |
| 6 | VSS | P | Negative power supply, ground |
| 7 | OUT | O | LED output pin |
| 8 | PHI | I | Detect environment sensor input pin |

Pin Type

I : CMOS input only
 O : CMOS output
 P : Power / Ground

Preliminary

PIR0001

ELECTRICAL CHARACTERISTICS**• Absolute Maximum Ratings**

| Parameter | Symbol | Conditions | Value | Unit |
|-----------------------|------------------|----------------------|-------------------|------|
| Operating Temperature | T _{OP} | — | -20 ~ +60 | °C |
| Storage Temperature | T _{STG} | — | -50 ~ +125 | °C |
| Power Supply Voltage | VBAT | T _a =25°C | VSS-0.3 ~ VSS+5.5 | V |
| Input Voltage | V _{IN} | T _a =25°C | VSS-0.3 ~ VDD+0.3 | V |
| Human Body Mode | ESD | — | 4 | KV |

Note : VSS symbolizes for system ground

• DC/AC Characteristics : (Test condition at room temperature=25°C)

| Parameter | Symbol | Test Condition | Min. | Typ. | Max | Unit |
|---------------------------|-------------------|-------------------------------|------|------|------|------|
| Operating Voltage | VBAT | | 3.6 | 4.5 | 5.5 | V |
| Internal Regulator Output | VDD | | 2.64 | 3.0 | 3.36 | V |
| System oscillator | F _{sys} | VDD=3V | | 16K | | Hz |
| Standby Current | I _{stby} | VDD=3V@VBAT=4.5V | | 20 | 30 | uA |
| OUT open sinking current | I _{OL} | VDD=3V, V _{DS} =0.3V | 250 | | | mA |
| Turn on delay time | T _{dly} | | | 16 | | Sec |

Preliminary

PIR0001

FUNCTION DESCRIPTION

1. PIR sensor detection recognizes condition. (**PIR_on=1**)
 - 1-1. Build-in Low offset op with gain about 20 multiple
 - 1-2. When lamp turn on change to turn off , then disable PIR 1 sec.
2. The PHI is a CMOS schmitt trigger input structure. It can use PHOTO transistor or CDS sensor to distinguish between **Day_time** and **Night_time**.
 - 2-1. PHI voltage $2/3VDD$ debonce 2sec, judge environment is **Night_time**
 - 2-2. PHI voltage $1/3VDD$ debonce 2sec, judge environment is **Day_time**
 - 2-3. $1/3VDD < PHI \text{ voltage} < 2/3VDD$, keep last state (**Day_time** or **Night_time**)
 - 2-4. PHI debounce noise
 - 2-5. The initial state is **Night_time** after power on
 - 2-6. When lamp turn on, keep environment **Night_time** state .
3. Turn on delay time(**TD_time**) fix 16 sec
4. PIR0001 OUT pin turn on and turn off state and timming as below :
Turn off : OUT pin is floating.
Turn on : OUT pin is PWM output → 0 : floating = 8mS : 4mS
5. Lamp turn on and turn off condition and **TD_time** recount condition as below table
Turn on condition : **Night_time** and **PIR_on=1**
Turn off condition : **TD_time** end
TD_time recount condition : **PIR_on=1**
6. PIR0001 has a **Initial_mode** time after power on. **Initial_mode** has 1 sec stable time and has fix 16 sec **Initial_TD_time** warm-up time. The warm-up time end depend on **Initial_TD_time** only.
Initial_TD_time recount condition : **PIR_on=1**.

Preliminary

PIR0001

APPLICATION CIRCUIT

PIR0001 application

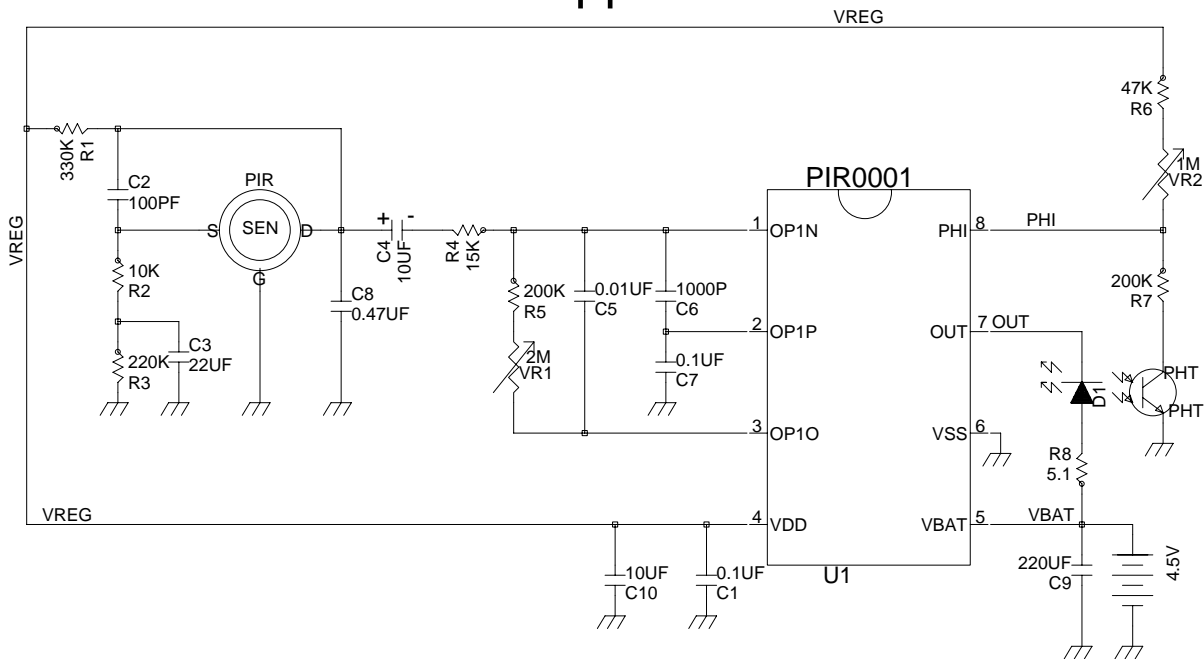

Preliminary

PIR0001

ORDER INFORMATION

A: Package form:

PIR0001A : DIP 8 pin

PIR0001B : SOP 8 pin

REVISE HISTORY

1. 2011/01/18

-Original version : V_0.1