

Preamplifiers



General

The following pages describe the amplifier circuits recommended for Judson photovoltaic and photoconductive detectors.

Current Mode Preamplifiers

The transimpedance (or current-mode) preamplifier circuit of Fig. 50-1 is recommended for most PV detector applications, for frequencies up to 1 MHz. It offers lowest noise and best linearity under a wide range of conditions.

The characteristics of the op-amp circuit maintain the diode near 0V bias. All the photocurrent from the detector essentially flows through the feedback resistor R_F .

The feedback capacitance C_F is added to control gain peaking (Fig. 50-2). The value of C_F depends on the detector capacitance. It is installed at the factory to provide stable preamplifier performance with a particular detector model.

The values of R_F and C_F , together with the detector characteristics R_D and C_D , determine the overall frequency response of the system (Figs. 51-2, 51-3, 53-2, 53-3).

Figure 50-1
Op-amp Circuit for PV Detectors

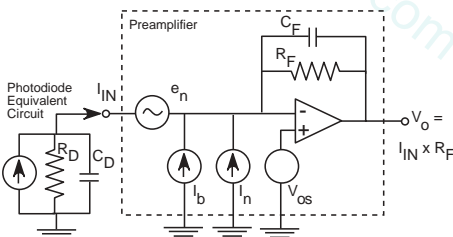
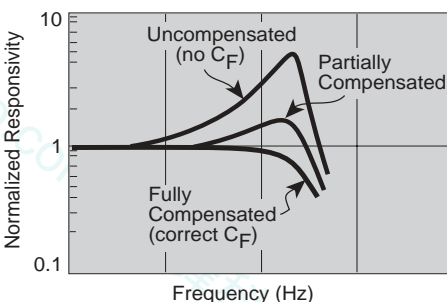

Figure 50-2
Illustration of Preamp Gain Peaking



Noise Sources

Figure 50-1 shows the various noise sources of the detector/preamplifier system. Values for the preamp noise sources e_n , i_n , V_{os} and I_b are listed in the specification tables for each Judson current-mode preamplifier.

The preamp noise sources, together with the detector characteristics, determine the system noise.

While a complete analysis of detector system noise is beyond the scope of this guide, the effects of the various noise sources can be summarized by the following approximation:

$$\text{Total } e_n(f) \geq \left[\frac{e_n^2}{Z_D^2} + i_n^2 + \frac{4kT}{R_D} + \frac{4kT}{R_F} \right]^{1/2} Z_F$$

where k is Boltzmann's constant and T is temperature in degrees Kelvin.

This simplified noise equation provides a good approximation of the total voltage noise density ($V/Hz^{1/2}$) at the preamplifier output. Note that the noise is dependent on the frequency f , and is normalized to a 1 Hz noise bandwidth.

The four terms in the brackets represent the four main sources of current noise:

- Preamplifier noise voltage e_n divided by the detector reactance Z_D , where $Z_D = R_D / (1 + (2\pi f)^2 C_D^2 R_D^2)^{1/2}$
- Preamplifier current noise i_n
- Johnson thermal current noise from the detector shunt resistance R_D
- Johnson thermal current noise from the preamp feedback resistance R_F

The total current noise is then multiplied by the transimpedance gain Z_F , where

$$Z_F = R_F / (1 + (2\pi f)^2 C_F^2 R_F^2)^{1/2}$$

Analysis of the simplified noise equation shows the following:

- In situations where Z_D is large ($>10k\Omega$) the preamplifier current noise i_n is more important than the voltage noise e_n . This is generally the case when using high-impedance detectors (InSb, cooled Ge, small-area Ge) at moderate frequencies. Choose a preamp with low i_n .

- In situations where Z_D is small ($<1k\Omega$), the preamp voltage noise e_n becomes more important. This is generally true with low-impedance detectors (InAs, large-area Ge). Choose a preamp with low e_n .

- Larger R_F adds less current noise. For highest sensitivity, R_F should be greater than R_D when practical.

Preamp Noise Figure

A general method for evaluating noise performance of a preamplifier is the noise figure, NF, which indicates what portion of the system noise is caused by the preamp.

$$NF = 10 \log_{10} \left[\frac{\text{Total Noise}}{\text{Detector Noise}} \right]$$

A perfect preamplifier has a Noise Factor of 0 dB, indicating that the preamp noise contribution is negligible compared to the detector noise. A NF of 0.1 to 3 dB is considered satisfactory. Preamps with NF >3 dB add significant noise to the system.

See Fig. 53-1 for noise figures of Judson transimpedance preamplifiers at 1 KHz.

DC Applications: Offset Drifting

In DC applications, the preamp input bias current I_b and input offset voltage V_{os} become important. In an ideal op-amp, I_b and V_{os} are zero. In reality they have non-zero values. Together with the detector R_D they produce a "dark current" I_D :

$$I_D = I_b + (V_{os}/R_D)$$

The DC offset voltage at the preamp output is equal to $I_D \times R_F$.

I_b and R_D each have a non-linear dependence on temperature. The offset voltage at the preamplifier output will therefore drift with temperature changes.

To minimize offsets and drifting:

- For high-impedance detectors, choose a preamp with low I_b .
- For low-impedance detectors, choose a preamp with low V_{os} .
- Consider stabilizing the detector temperature by using one of Judson's integral TE-cooler packages.

Description

The PA-9 preamplifier is ideal for high-frequency performance with high-impedance photovoltaics such as cryogenically cooled InSb and Ge.

The PA-9 offers low current noise and ultra-low voltage noise. However, its relatively high DC offset voltage makes it less suitable for DC applications than other Judson preamps.

The PA-9 has fixed gain. When ordered with a detector, the preamp is matched to the detector for maximum gain and sensitivity. Alternatively, the customer may specify gain or minimum required bandwidth.

Bandwidth is a function of detector resistance and capacitance as well as preamp gain (Figs. 51-2 and 51-3).

Gain Stages

The PA-9 has a first stage transimpedance gain and a second stage voltage gain. Output from each stage is accessible.

Normal first stage gain is 10^7 , 10^6 , 10^5 or 2.5×10^4 V/A. For lowest noise, choose the highest gain possible to achieve the desired bandwidth. (Note: when used with an InSb detector, first-stage gain must be low enough to avoid DC saturation from the detector Background Current I_{BG} .)

The second stage is normally AC coupled with a 20dB gain (~10x). It may be DC coupled per customer specifications.

Features

- Superior High-Frequency Performance (500Hz to 1MHz)
- Ultra-low Voltage Noise
- Ideal for PV detectors: J10D, J16D and J16TE2

Figure 51-1
PA-9 Preamplifier

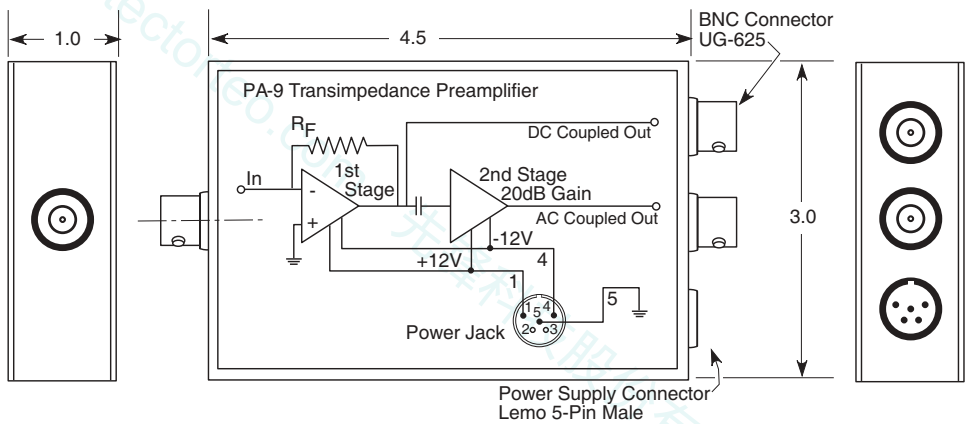

Connections

Input and output connections are BNC feed-throughs. The power jack is a 5-pin male Amphenol connector; the mating female Amphenol connector is provided.

Gain/Bandwidth Specifications Model PA-9 Preamplifier

Model	1st Stage Gain (V/A)	1st Stage Bandwidth (Maximum) See Figs. 51-2, 51-3
PA-9-70	10^7	DC to 100KHz
PA-9-60	10^6	DC to 300KHz
PA-9-50	10^5	DC to 750KHz
PA-9-44	2.5×10^4	DC to 1MHz

Figure 51-2
PA-9 Bandwidth vs Detector Capacitance

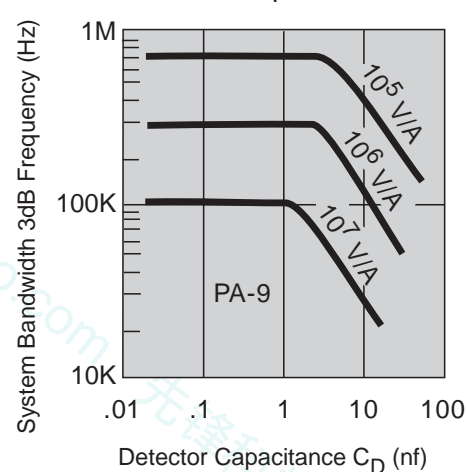
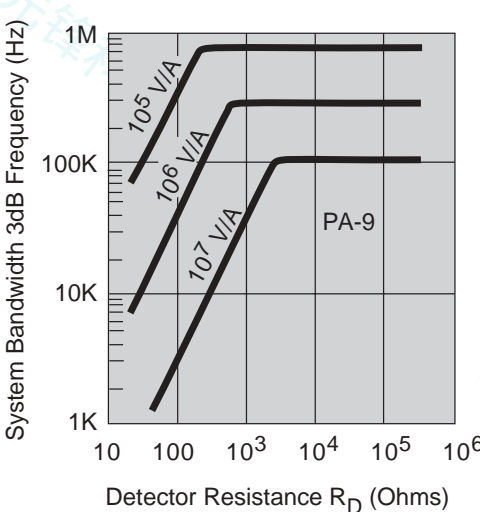

Figure 51-3
PA-9 Bandwidth vs Detector Resistance



Typical Specifications Model PA-9 Preamplifiers

2nd Stage Gain	20	dB
Voltage Noise Density @ 1KHz	6.5	nV Hz ^{-1/2}
Voltage Noise from 0.1 to 10 Hz	1.0	μVpp
Current Noise Density @ 1KHz, 10^7 Gain †	0.04	pA Hz ^{-1/2}
Input Offset Voltage	± 10	mV
Input Bias Current	± 1	pA
Maximum Output	1st stage = 6 2nd stage = 10	Vpp
Output Impedance	< 50	Ω
Power Requirements	+12 and -12 20	VDC mA

† Lower gain increases Current Noise Density



General

Current Mode Preamplifiers convert the current output of a photovoltaic Ge, InAs, or InSb detector into a voltage output. They amplify the signal for subsequent use with oscilloscopes, lock-in amplifiers, or A-to-D converters.

Three different preamp models each offer specific advantages, depending on detector type and bandwidth requirements. A comparison of preamp noise figure as a function of detector reactance is graphed in Fig. 53-1.

All units (except multi-channel models) have switch-selectable gain.

PA-7

The PA-7 is an excellent general purpose preamplifier for most high shunt resistance ($R_D > 25K\Omega$) detectors, including small area J16 Series Ge and all J16TE2 Series cooled Ge. It has extremely low current noise and current offset.

For most applications, the PA-7-70 with high gain of 10^7 V/A offers best performance and versatility. However, for applications where 10^7 V/A gain is unusable (due to bandwidth or DC saturation), the PA-7-60 or PA-7-50 are suitable alternatives.

PA-6

The PA-6 is a general purpose preamplifier recommended for intermediate shunt resistance ($400\Omega < R_D < 50K\Omega$) detectors, including large area J16 Series room temperature Ge. The PA-6 has very low voltage noise and offset voltage, which significantly reduces low-frequency noise and DC drift. Standard gain settings are listed in the specification table below; custom gain settings are available.



PA-5

The PA-5 is recommended for low impedance detectors ($R_D < 400\Omega$), including J12 Series room temperature InAs and J12TE2 Series InAs. It has extremely low voltage noise and low voltage offset. However, its high current noise and current offset make it unsuitable for detectors with high impedance.

Standard gain is 10^5 , 10^4 , and 10^3 V/A (switch-selectable). Custom gain settings are available.

Figure 52-1
Equivalent Circuit for Transimpedance Preamplifier

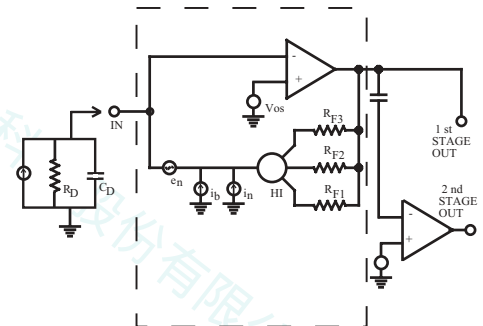

Typical Specifications Model PA-5, PA-6 and PA-7 Current Mode Preamplifiers @25°C

Model	PA-7 Series			PA-6 Series		PA-5	Units	
	PA-7-70	PA-7-60	PA-7-50	PA-6-60	PA-6-50	PA-5-50		
Transimpedance Gain: (Switch Selected)	High	10^7	10^6	10^5	10^6	10^5	V/A	
	Med	10^6	10^5	2.5×10^4	10^5	2.5×10^4		
	Low	10^5	2.5×10^4	10^4	2.5×10^4	10^4		
Bandwidth	@ High Gain	8	60	150	60	150	200	KHz
$R_D > 10K\Omega, C_D < 0.2nF$	@ Med Gain	60	150	200	150	200	200	
(See Figs. 53-2, 53-3)	@ Low Gain	150	200	200	200	200	200	
Input Offset Voltage (V_{OS})		± 250	± 250	± 250	± 100	± 100	± 80	μV
Input Bias Current (i_b)		± 0.001	± 0.001	± 0.001	± 12	± 12	± 30	nA
Voltage Noise Density (e_n)@1KHz		12	12	12	4.5	4.5	1.1	$nV Hz^{-1/2}$
Voltage Noise from 0.1 to 10Hz		1.5	1.5	1.5	.080	.080	.035	μV_{pp}
Current Noise Density (i_n)@1KHz†		.04	.13	.04	.5	.64	1	$pA Hz^{-1/2}$
Output Impedance	< 100						Ω	
Maximum Output Voltage	± 10						V _{pp}	
Power Requirements	$+12V$ and $-12VDC$ @ 10mA							
Recommended for Detector Series:	J16, J16TE1, J16TE2, J16D, J10D			J16, J12TE2, J12TE3		J12 J12TE2		

† At High Gain Setting.



Figure 53-1
Preamplifier Noise Figure @ 1kHz (See page 44)

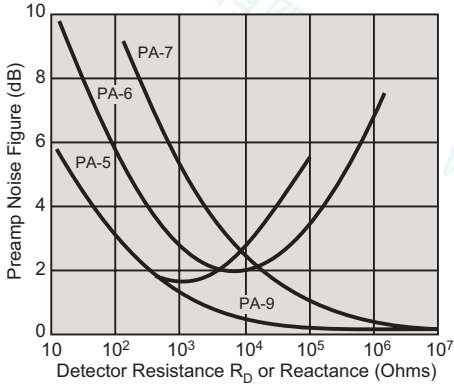

Figure 53-2
System Bandwidth vs Detector Capacitance

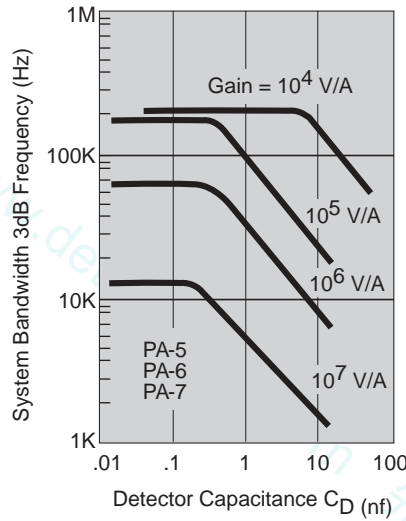

Figure 53-3
System Bandwidth vs Detector Resistance

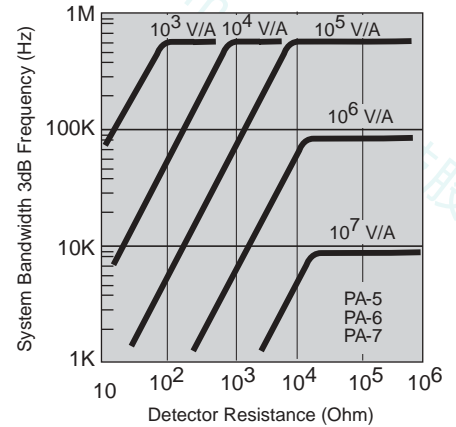

Figure 53-4
Dark Current vs Resistance and Preamp

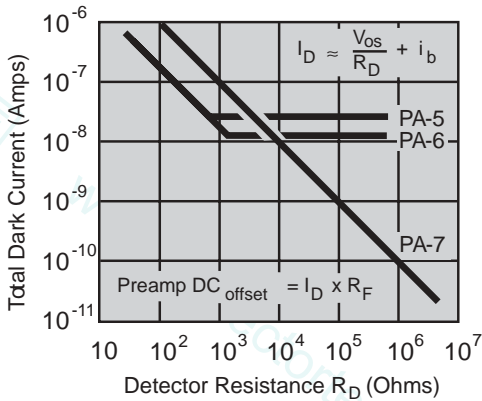
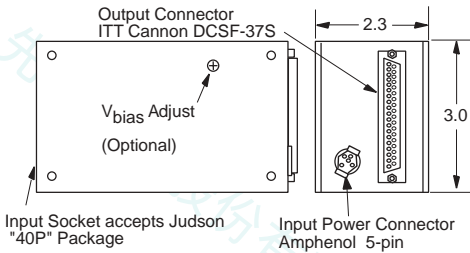

Figure 53-5
PA-7:4C, PA-7:16C and PA-7:32C Multi-channel Preamp



Typical Specifications Multi-Channel Preamp

Model	# of Channels	Gain (V/A)	Bandwidth (Max) See Figs. 53-2, 53-3
PA-7:4C-70	4		
PA-7:16C-70	16	10 ⁷	DC to 10KHz
PA-7:32C-70	32		
PA-7:4C-60	4		
PA-7:16C-60	16	10 ⁷	DC to 60KHz
PA-7:32C-60	32		
PA-5:4C-1E3	4	10 ³	DC to 200KHz

Input Offset Voltage (V _{os})	±200	μV
Input Bias Current (i _b)	±40	pA
Voltage Noise Density (e _n) @1KHz	18nVHz ^{-1/2}	
Voltage Noise from 0.1 to 10 Hz	2	μVpp
Current Noise Density† i _n @ 1KHz	.01pAHz ^{-1/2}	
Output Impedance	< 100	Ω
Maximum Output Voltage	±10	Vpp
Power Requirements	±15	VDC
PA-7:4C (4 channel)	@ 40	ma
PA-7:16C (16 channel)	@ 40	ma
PA-7:32C (32 channel)	@ 80	ma
Use with Detector Series:	Ge Arrays	

† At Gain = 10⁷ V/A. Lower gains increase Current Noise Density.

PA-7:4C, PA-7:16C, and PA-7:32C

Multi-Channel Preamp

The PA-7:4C, PA-7:16C and PA-7:32C Series multi-channel preamp are designed primarily for use with Judson's Germanium Array Series and X-Y Sensors.

The preamp gain is fixed as specified at the time of purchase. Standard gain settings are 10⁷ or 10⁶ V/A; others are available on a custom basis.

While zero-bias is recommended for J16P Series arrays in most applications, the preamp is also available with an optional detector bias adjust. Biasing the photodiodes improves response time and high-power linearity, but also increases dark current.

Preamplifiers



General

Voltage Mode Preamplifiers may be used with photoconductive HgCdTe or with low-impedance photovoltaics such as InAs.

With photoconductive detectors, a constant bias current or constant bias voltage is applied across the detector element. The element changes resistance in response to incident photons, and the resulting change in voltage is amplified by the preamp. A blocking capacitor or DC offset circuit is required to block the constant DC bias.

With photovoltaic detectors, the photocurrent generated in the detector induces a voltage across the preamp input impedance. This voltage is amplified. A lower input impedance generally results in faster frequency response, but also adds more noise to the system.

PA-101

HgCdTe Preamplifier (10 Hz - 1 MHz)

The Model PA-101 low-noise voltage preamplifier is recommended for all J15 Series HgCdTe detectors.

An external bias resistor is used to set the constant bias current required for PC detector operation.

When purchased with a detector, the preamp includes a bias resistor factory-selected for optimum detector performance. When ordering the preamp separately, please specify detector cold resistance and required bias current or bias voltage.



PA-300

HgCdTe Preamplifier (DC - 1.0 MHz)

The Model PA-300 current preamplifier is designed for operation with J15D Series HgCdTe detectors.

The PA-300 is designed using a bridge circuit on the front end of an operational amplifier to deliver constant bias voltage across the detector.

The PA-300 is recommended for detectors used over a wide dynamic range in applications including FTIR's and laser monitoring. The PA-300 also has a first order linearity correction in the form of a positive feedback resistor.

PA-8200

PbS and PbSe Preamplifier

The Model PA-8200 low-noise voltage preamplifier is recommended for all J13 and J14 Series detectors. A load resistor is selected to match the detector resistance.

Preamp gain and typical bandwidth specifications are listed in the table opposite. For best results, choose the preamp model with the narrowest suitable bandwidth to keep preamp noise to a minimum.



Typical Specifications Judson Voltage Mode Preamplifiers

Model	Gain	Bandwidth (Hz)	Input Noise Voltage (nV Hz ^{-1/2})	Input Impedance (Ω)	Max. Output (Load ≥ 1KΩ) (Vpp)	Detector Bias	Power Requirement		Case Dimensions (Including Connectors)
							(V _{DC})	(mA)	
PA-101	1st x100 2nd x10	10Hz to 1MHz	1.5	10K *	10	Built-in	±15	200	4.125" x 2.5" x 1.75"
PA-300	100, 300, 1000	DC to 1.0MHz	1.5	100K	10	Built-in	±15	200	4.125" x 2.5" x 1.75"
PA-8200	12 to 300	10KHz	1.5	50K	10	External	±15	200	3.125" x 3" x 1"

* Through 100µf capacitor

Figure 55-1
PA-101 Preamp Equivalent Circuit

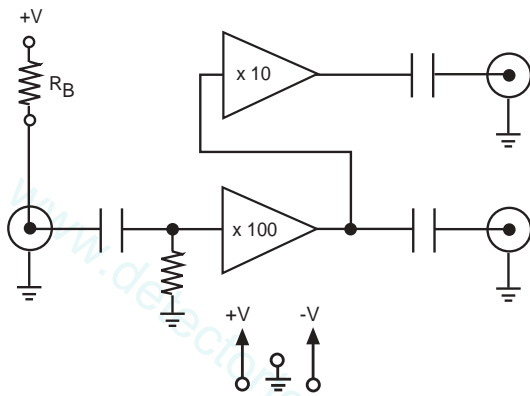

Figure 55-3
PA-300 Preamp Equivalent Circuit

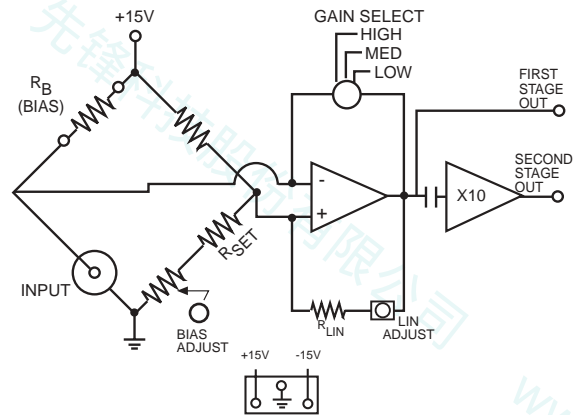
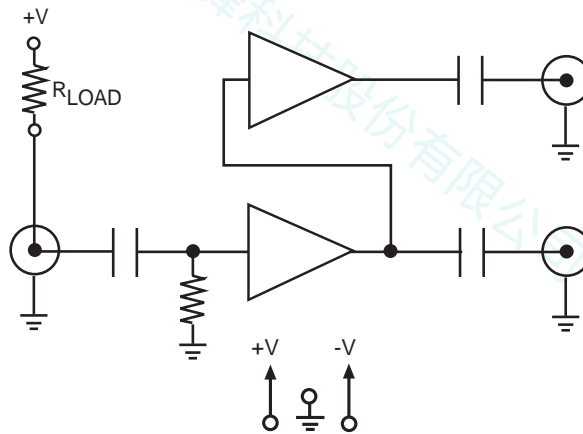

Figure 55-4
PA-8200 Preamp Equivalent Circuit



TC6 Temperature Controllers



General

The TC6 is a self contained Thermo-electric Cooler Temperature Controller for single and multistage TEC cooled photodetectors housed in TO-8, TO37, and other TO style packages. Using a single 5 Volt power supply, the TC6 operates in conjunction with a thermistor, located in the detector assembly, to precisely measure and regulate the temperature of the cooled detector. The detector assembly temperature is set with a single resistor that is equal to the thermistor resistance at the desired set temperature. The detector manufacturer generally specifies the optimum detector operating temperature and corresponding thermistor value

The TC6 contains a connector (P3) for optional monitoring of the TEC current, the current through the temperature set resistor output of the thermistor bridge. Pins on this connector can also be used to set detector temperature with an external resistor or current source if desired. In addition, a solid state switch closure and the illumination of an on board LED is provided when the detector temperature is within $\pm 2^{\circ}\text{C}$ of the programmed temperature.

Interconnect cables are provided with each TC6 controller to interface with the power supply and the detector assembly (TEC-thermistor). A cable is also provided to interface with connector P3.

TC6 Monitor

The TC6 monitor fixture is available and provides an easy way to measure the various outputs provided on connector P3. A DVM is connected to the output of this fixture and a five position switch allows monitoring of the output of the thermistor bridge, the TEC current, the current through the temperature set resistor, the +5 Volt internal reference and the +5 Volt external power supply. The TC6 does not require the TC6 monitor for proper operation, however, it provides a convenient way to set up the TC6 if moderate quantities of this TEC controller are used.



FEATURES

- PRECISE TEMPERATURE CONTROL
- TEMPERATURE STABILITY TO $\pm 0.02^{\circ}\text{C}$
- TEMPERATURE SET WITH A SINGLE RESISTOR
- SINGLE +5 VOLT POWER SUPPLY OPERATION
- OPERATES WITH MOST TEC COOLED DETECTORS
- MAXIMUM TEC CURRENT ADJUSTABLE TO 2 AMPS
- LED TEMPERATURE STABILIZATION INDICATOR
- TEC CURRENT MONITOR
- THERMISTOR BRIDGE MONITOR
- SMALL SIZE
- DETAILED INSTRUCTION MANUAL PROVIDED

The various electrical inputs and outputs of the TC6 can be monitored and/or controlled through this connector if desired. Making connection to the TC6 through this connector is not necessary to the operation of the controller.

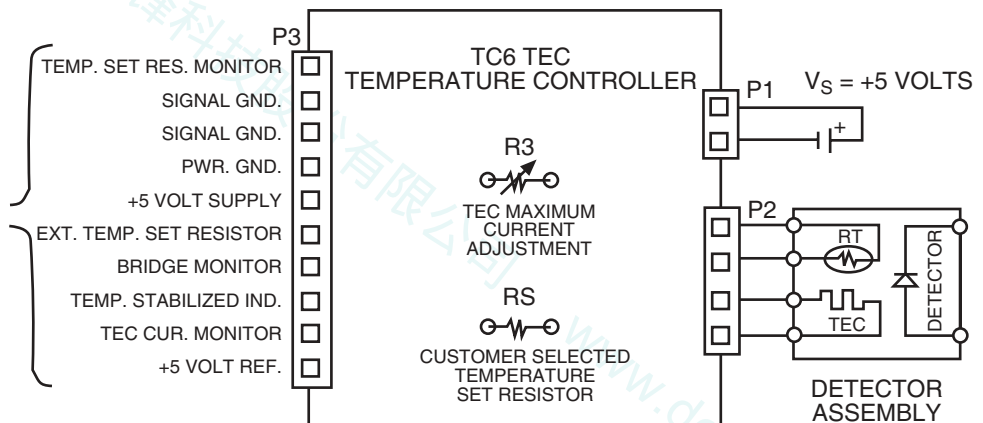



The figures on this page illustrate the location and function of the connectors and components on the TC6. The temperature set resistor (RS1 or RS2) are customer installed. Selection of the fixed resistor RS1 or variable resistor RS2 is made by placing a jumper in the specified location on connector JP2. A 1 ohm ballast resistor is provided on the TC6. this resistor is in series with the TEC and is used to properly match the TC6 to very low resistance TECs. This resistor can be shorted out if not needed by placing a jumper across JP1. The various control voltages of the TC6 can be monitored through connector P3. The pin location of these signals is shown below.

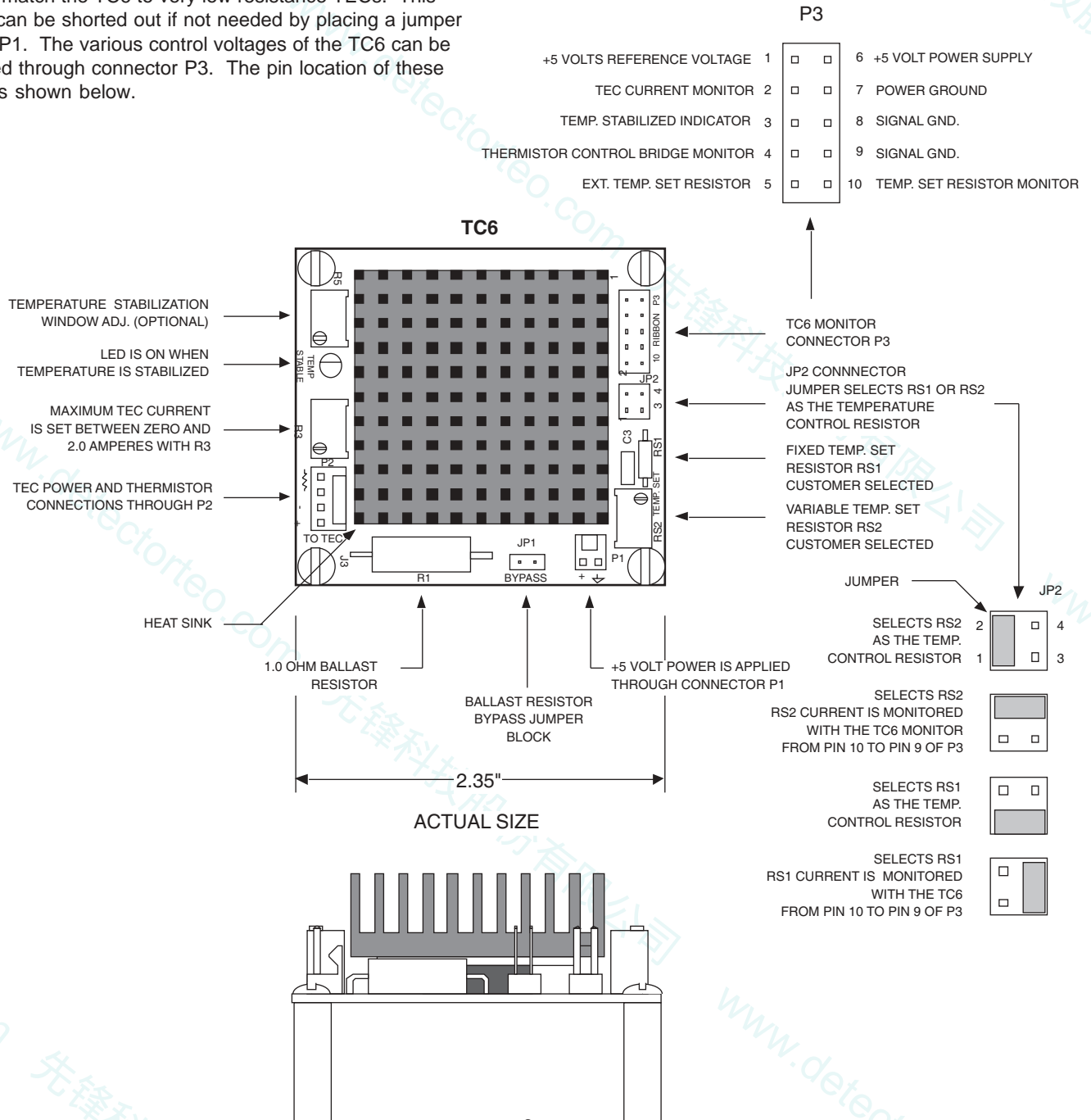

Thermoelectric Cooler Accessories



Description

A thermoelectrically cooled detector requires a heat sink to dissipate the heat generated by the cooler, an amplifier to amplify the detector signal to a usable level and a temperature controller to hold the detector at a constant temperature. Judson TE cooler accessories are designed to give solutions for these problems to our customers.

HS1 Assembly (Heat Sink Assembly for TO-66 and TO-3 Packages)

The HS1 series is designed to provide heat sinking and cabling to simplify integrating a TE cooled detector into an existing system, and is designed to mate with either the TC-5 or TC-6 temperature controllers.

HSAMP Assembly (Heat Sink and Amplifier Assembly for TO-66 and TO-3 Packages)

The HSAMP series is designed to provide both heat sinking and signal amplification for our TE cooled photovoltaic product line. This allows Judson to help a customer to choose the best amplifier for a particular detector and system. The HSAMP includes a hybrid PA-5, PA-6 or PA-7 preamplifier and is designed for easy connection to the customer's optical system and the TC-6 Temperature Controller.



HS1 Assembly/HSAMP Assembly

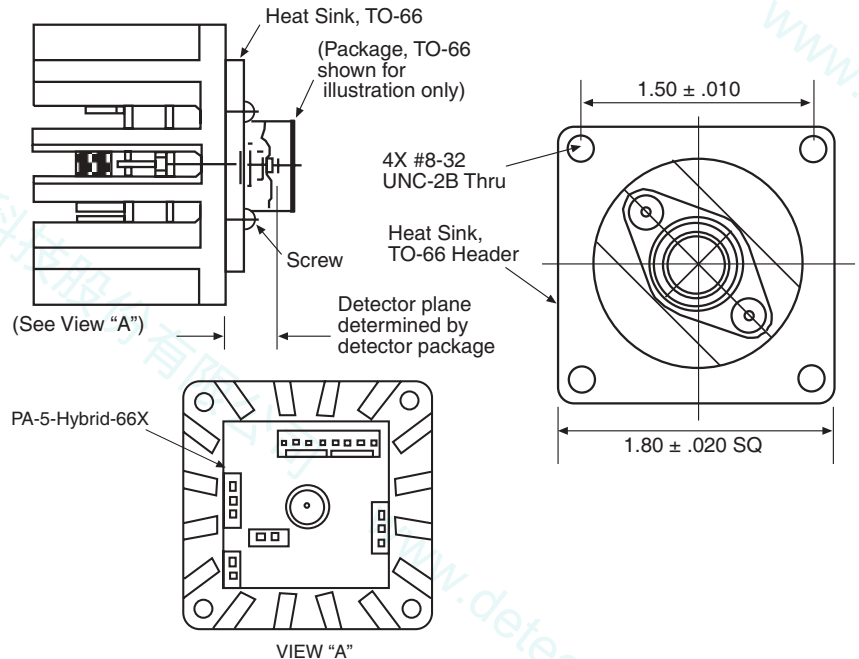



Model	HSAMP1-TO66-TC6-PA5	HSAMP1-TO66-TC6-PA7	HSAMP1-3CN-TC6-PA7	Units
Part Number	490114	490140	490143	
Description	Heat sink/Socket/PA-5 amplifier/Cables for TO-66 PV detectors/TC6 controller	Heat sink/Socket/PA-7 amplifier/Cables for TO-66 PV detectors/TC6 controller	Heat sink/Socket/PA-7 amplifier/Cables for 4-stage PV detectors/TC6 controller	
Transimpedance	High	10^5	10^7	μ/A
Gain:	Med	10^4	10^6	
(Switch Selected)	Low	10^3	10^5	
Bandwidth	@ High Gain	200	8	KHz
$R_D > 10K, C_D < 0.2nF$	@ Med Gain	200	60	
	@ Low Gain	200	150	
Input Offset Voltage (V_{os})		±40	±100	μV
Input Bias Current (i_b)		±90	±.005	nA
Voltage Noise Density (e_n)@1KHz		1.5	8	nV/√Hz
Voltage Noise from 0.1 to 10Hz		.035	1.6	μV
Current Noise Density (i_n)@1KHz†		1.6	.04	pA/√Hz
Output Impedance	< 100			Ω
Maximum Output Voltage	±15V			P-P
Power Requirements	+15V and -15V @ 10mA			
Recommended for Detector Series:	J12, J12TE1	J12TE2, J16 Series	J12TE2, J16 Series	

† At high gain setting

HSAMP and CMAMP Operating Circuit

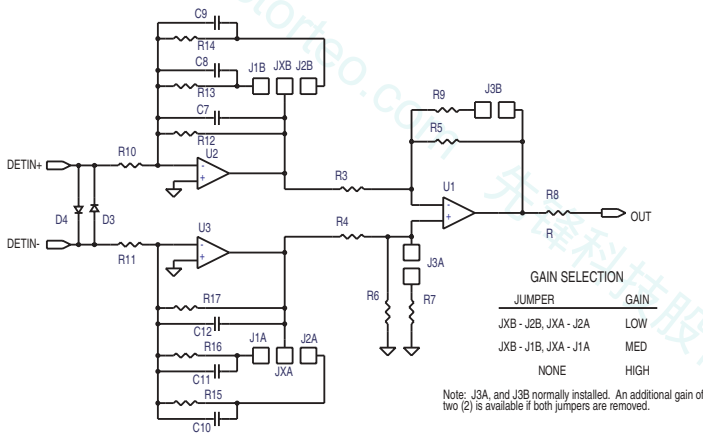

Judson Hybrid Preamp Configuration

CM21 Assembly (Heat Sink and Temperature Controller for TO-66 and TO-3 Packages)

The CM21 assembly is designed to provide heatsinking and temperature control for Judson's TE cooled photoconductive and photovoltaic detector product line. It is designed to simplify integrating a TE cooled detector into an existing system with a customer supplied amplifier. The CM21 assembly is ideal for customers who have designed their own amplifier for their system.

CMAMP Assembly (Heat Sink Amplifier and Temperature Controller for TO-66 and TO-3 Packages)

The CMAMP series is designed for customers that would like a fully integrated detector module. It includes heatsinking, detector signal amplification and temperature control. The CMAMP assembly requires an external power supply that provides both +5V @ 2.0 amperes and ±15 volts at 100mA. The CMAMP assembly is an ideal platform for evaluating TE cooled detectors for the first time. Custom mechanical assemblies including temperature control, detector amplification and heat sinking are available on an OEM basis.

Thermoelectric Cooler Accessories



CM21 Assembly / CMAMP Assembly

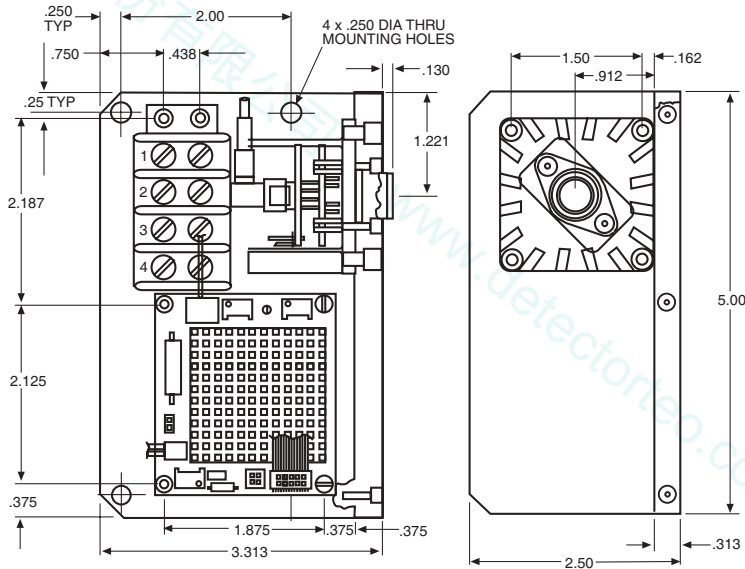

Model Number	Part Number	Heat sink	Package Socket	Cables	Amplifier	Temp. Controller	Power Requirements		
HS1	600613-1	HS1	9 pin TO-66 66G, 66S, 66C, 66GE, 66D	N/A	N/A	N/A	N/A		
HS1-T066-TC6	490117			Detector-BNC Cooler to TC6					
HS1-T066-TC5	490094			Detector-BNC Cooler to TC5					
HS1-3CN-TC6	490120		8 pin TO-3 3CN	Detector-BNC Cooler to TC6					
HS1-3C12-TC6	490151		3C12						
HS1-T066-TC6-PS	490138		Detector-Lemo Cooler to TC6						
HSAMP-T066-TC6-PA5	490114		9 pin TO-66 66G, 66S, 66C, 66GE, 66D	From Amp SMA to BNC Cooler to TC6				PA-5-HYBRID	+/-15V @10mA
HSAMP-T066-TC6-PA6	490147							PA-6-HYBRID	
HSAMP-T066-TC6-PA7	490140							PA-7-HYBRID	
HSAMP-3CN-TC6-PA7	490143							8 pin 3CN	
CM21 ASSEMBLY-TO66	490102	CM1	9 pin TO-66 66X	Detector-BNC	N/A	TC6	+5V +/- .25 @ 2A		
CM21 ASSEMBLY-TO66-PS	490118			Detector-Lemo					
CM21 ASSEMBLY-3CN	490122		8pin 3CN	Detector-BNC					
CM21 ASSEMBLY-3C12	490150		12 pin TO-3						
CMAMP-T066-PA5	490130		9 pin TO-66 66X	12" RG174 SMA-BNC				PA-5-HYBRID	+5V +/- .25 @ 2A +/-15V@10mA
CMAMP-T066-PA6	490146						PA-6-HYBRID		
CMAMP-T066-PA7	490139						PA-7-HYBRID		
CMAMP-3CN-PA5	490132						8 pin TO-3 3CN	PA-5-HYBRID	
CMAMP-3CN-PA7	490141		PA-7-HYBRID						

TC5 Temperature Controllers

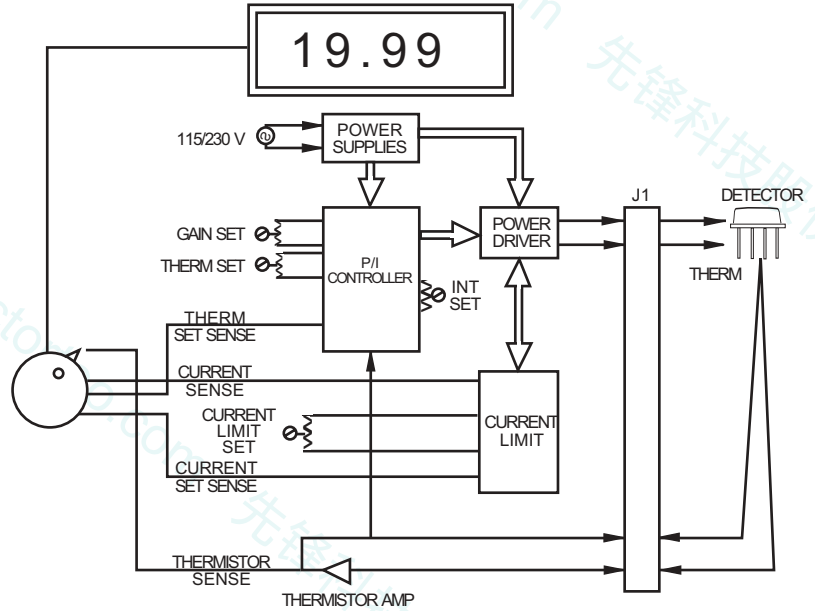

General

The TC5 controller is one of several models of controllers manufactured by Judson Technologies designed to provide high stability temperature control with a design approach that is user friendly. Figure 1 is a block diagram that illustrates the major components of this controller.

Principle of Operation

Please refer to Figure 1 as the following section is reviewed. The controller is powered by standard AC input voltages (115 or 230). Incoming AC voltage is converted to low voltage DC for use by the control circuitry. These low power voltages are available on the rear panel connector J1 and can be used to power low voltage external circuitry. Also included in the controller is a separate DC voltage power source for driving the thermoelectric cooler (TC).

The resistance of the thermistor used to measure the temperature of the TC is converted to a DC voltage and compared to the voltage used to establish the set point. The difference between the set

point voltage and the voltage resulting from the conversion of the thermistor resistance is amplified and applied to a power driver. The power driver controls the current flowing in the TC to bring the thermistor resistance equal to the set point. While this is occurring, an integral term is developed to maintain the required current flow to the TC when there is no difference between the set point and the thermistor resistance.

The current limit control prevents TC currents from exceeding the preset value (Imaximum for thermoelectric cooler). This feature helps to prevent damage or reduced performance of the TC.