



High-Resolution X-Ray Camera HR-25-X-Ray



Model HR-25-X-Ray

Applications:

- X-ray imaging for PCB control and drilling
- X-ray transmission of small objects
- Beam adjustments
- X-ray imaging of diffraction or spectral patterns
- Open face versions for UV and electron detection on request

Technical data HR-25-X-Ray

CCIR 2/3" Camera	
CCD format	2/3"
CCD pixel	752 x 582 (H x V)
CCD pixel size	11,6 μm x 11,2 μm (H x V)
Operation	CCIR, interlaced 2:1 with several functions: frame/field exposure, electronic shutter 10 μs ..10ms, exposure control with switches or pulse width, different trigger modes, WEN (Write Enable) signal, restart/reset mode, internal/external synchronisation, connectors : 12 pole multi-functional in/out, BNC, power requirement 12V +/- 10%, EIA output available

Camera Specification	
Field of view	20 mm x 15 mm
Phosphor Coating	P43
Input window	Aluminium 0,5 mm or different material on customer request (also "open face" for UV or electron sensitivity)
Typical sensitivity range	about 20 to 100 keV (x-ray, other on request)
Resolution	about 50 μm (preliminary)
Dimensions camera head	Compact design: diameter 55 mm length 68 mm

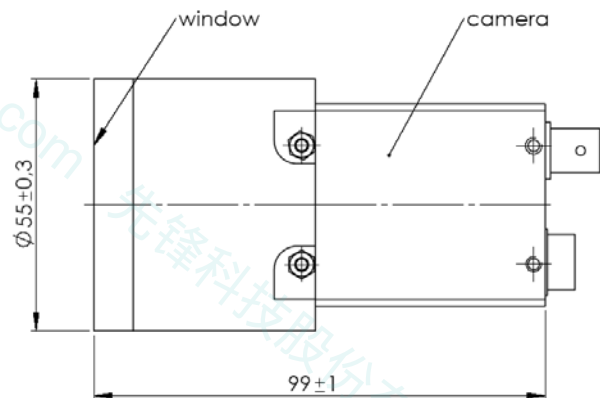

Camera can be modified on request to fit to customer requirements (please specify the radiation to be detected):

- type and thickness of coating
- additional layers
- type and thickness of input window

Progressive-scan camera types available

GigE, USB, IEEE1394 ("FireWire")-Interface camera types available

(housing geometry, CCD size and pixel size/number vary, please place you request)

For customised versions please contact us. Based on our engineering and production facilities special versions can be realised.