

HTM226LF – Temperature and Humidity Module

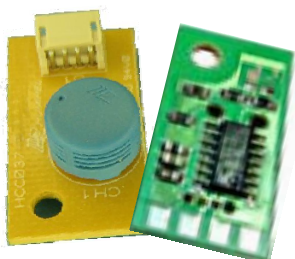

- Full Lead free product
- Calibrated within +/-5% @55%RH at 5Vdc
- Small size and very cost effective
- Miniature connector (JST)
- 50kOhms +/-3% NTC temperature sensor @25°C



DESCRIPTION

Based on the rugged HS24LF resistive humidity sensor, HTM226LF is a dedicated **humidity and temperature transducer** designed for OEM applications where a reliable and accurate measurement is needed. It features a very small size for easy, cost-effective mechanical mounting. Direct interface with a micro-controller is made possible with the module's linear **voltage output**.

FEATURES

- The best combination of cost effectiveness and performance
- Stable, linear proportional voltage output from 0% to 95%RH
- Stable and reproducible characteristics with temperature
- High reliability and long term stability

APPLICATIONS

- Air condition, Humidifier, Dehumidifier
- Humidity controller, Humidity transmitter
- Hygrometer, Hygro-recorder
- Copying machine
- Clock, Weather-forecast barometer

PERFORMANCE SPECS

MAXIMUM RATINGS

Ratings	Symbol	Value	Unit
Storage Temperature	Tstg	-20 to 80	°C
Storage Humidity	RHstg	0 to 100	% RH
Supply Voltage (Peak)	Vs	16	Vdc
Humidity Operating Range	RH	0 to 95	% RH
Temperature Operating Range	Ta	-20 to 60	°C

Peak conditions: less than 10% of the operating time.

HTM226LF - Temperature and Humidity Module

ELECTRICAL CHARACTERISTICS

(Ta=25°C, Vs=5Vdc +/-5%)

Humidity Characteristics	Symbol	Min	Typ	Max	Unit
Humidity Metrology Range	RH	20		85	%RH
Relative Humidity Accuracy (@25°C, 55%RH, Vcc= 5Vdc)	RH		+/-5		%RH
Supply Voltage	Vs	4.75	5.00	5.25	Vdc
Nominal Output @55%RH ⁽¹⁾	Vout	1650	1815	1980	mV
Current consumption	Ic		2	5	mA
Average Sensitivity from 33% to 75%RH	$\Delta V_{out}/\Delta RH$	30	33	35	mV/%RH
Temperature coefficient (10°C to 40°C)	T _{cc}		-0.1		mV/°C

(Ta=25°C)

Temperature Characteristics	Symbol	Min	Typ	Max	Unit
Nominal Resistance @25°C	R	48.5	50.0	51.5	kΩ
Beta value: B25/85	β	3930	4050	4170	K
Temperature Measuring Range	Ta	-20		80	°C
Nominal Resistance Tolerance @25°C	R _N		3		%
Beta Value Tolerance	β		3		%
Response Time	τ		10		s

TYPICAL PERFORMANCE CURVES

HUMIDITY SENSOR

- Modeled signal output

Vout = 33*%RH (with Vout in mV and RH in %)

- Typical response look-up table

RH (%)	20	25	30	35	40	45	50
Vout (mV)	660	825	990	1155	1320	1485	1650
RH (%)	55	60	65	70	75	80	85
Vout (mV)	1815	1980	2145	2310	2475	2640	2805

TEMPERATURE SENSOR

- Typical temperature output

Depending on the needed temperature measurement range and associated accuracy, we suggest two methods to access to the NTC resistance values.

$$R_T = R_N * e^{\beta(\frac{1}{T} - \frac{1}{T_N})}$$

R_T NTC resistance in Ω at temperature T in KR_N NTC resistance in Ω at rated temperature T in KT, T_N Temperature in K

β Beta value, material specific constant of NTC in K

e Base of natural logarithm (e=2.71828)

HTM226LF - Temperature and Humidity Module

① The actual characteristic of an NTC thermistor can, however, only be roughly by the exponential relation as the material parameter β in reality also depends on temperature. So this approach is suitable for describing a restricted range around the rated temperature or resistance with sufficient accuracy.

② For practical applications, a more precise description of the real R/T curve may be required. Either more complicated approaches (e.g. the Steinhart-Hart equation) are used or the resistance/temperature relation as given in tabulation form. The below table has been experimentally determined with utmost accuracy for temperature increments of 1 degree.

- Temperature look-up table

Temp (°C)	Rmin (kΩ)	Rtyp (kΩ)	Rmax (kΩ)
-20	442,536	488,511	538,776
-19	418,459	461,133	507,703
-18	395,841	435,461	478,614
-17	374,586	411,375	451,371
-16	354,603	388,769	425,844
-15	335,806	367,542	401,915
-14	318,118	347,600	379,472
-13	301,467	328,858	358,416
-12	285,785	311,237	338,650
-11	271,010	294,662	320,090
-10	257,084	279,065	302,652
-9	243,953	264,382	286,264
-8	231,567	250,555	270,856
-7	219,880	237,528	256,363
-6	208,847	225,251	242,726
-5	198,429	213,677	229,889
-4	188,588	202,760	217,801
-3	179,288	192,461	206,414
-2	170,498	182,740	195,684
-1	162,185	173,562	185,569
0	154,322	164,894	176,031
1	146,882	156,704	167,033
2	139,840	148,965	158,542
3	133,172	141,648	150,527
4	126,857	134,728	142,958
5	120,874	128,182	135,810
6	115,204	121,988	129,055
7	109,830	116,125	122,671
8	104,733	110,574	116,635
9	99,899	105,316	110,927
10	95,312	100,335	105,527
11	90,959	95,614	100,417
12	86,827	91,139	95,579
13	82,903	86,896	91,000
14	79,176	82,872	86,662
15	75,636	79,054	82,553
16	72,271	75,431	78,658
17	69,073	71,992	74,967
18	66,032	68,727	71,467
19	63,140	65,626	68,148
20	60,389	62,680	65,000
21	57,771	59,881	62,012
22	55,280	57,221	59,176
23	52,909	54,692	56,484
24	50,651	52,287	53,928
25	48,500	50,000	51,500
26	46,328	47,824	49,325
27	44,263	45,754	47,252
28	42,301	43,783	45,277
29	40,435	41,907	43,393
30	38,661	40,121	41,598

Temp (°C)	Rmin (kΩ)	Rtyp (kΩ)	Rmax (kΩ)
31	36,973	38,419	39,886
32	35,368	36,798	38,253
33	33,840	35,254	36,694
34	32,385	33,782	35,207
35	31,001	32,379	33,788
36	29,682	31,041	32,433
37	28,427	29,765	31,139
38	27,230	28,548	29,903
39	26,090	27,387	28,723
40	25,004	26,279	27,595
41	23,968	25,222	26,517
42	22,980	24,212	25,487
43	22,038	23,248	24,502
44	21,140	22,327	23,560
45	20,282	21,448	22,659
46	19,464	20,607	21,797
47	18,684	19,804	20,973
48	17,938	19,037	20,184
49	17,226	18,303	19,429
50	16,546	17,601	18,706
51	15,897	16,930	18,014
52	15,277	16,288	17,351
53	14,684	15,674	16,716
54	14,117	15,086	16,107
55	13,575	14,524	15,525
56	13,057	13,985	14,966
57	12,561	13,470	14,431
58	12,087	12,976	13,917
59	11,634	12,503	13,425
60	11,200	12,050	12,953
61	10,785	11,616	12,500
62	10,387	11,200	12,065
63	10,006	10,801	11,649
64	9,642	10,419	11,248
65	9,293	10,052	10,864
66	8,958	9,701	10,496
67	8,637	9,364	10,142
68	8,330	9,040	9,802
69	8,036	8,730	9,475
70	7,753	8,432	9,161
71	7,483	8,146	8,860
72	7,223	7,871	8,570
73	6,974	7,608	8,291
74	6,735	7,354	8,023
75	6,506	7,111	7,766
76	6,286	6,878	7,518
77	6,075	6,653	7,280
78	5,872	6,437	7,051
79	5,677	6,230	6,831
80	5,490	6,031	6,618

HTM226LF - Temperature and Humidity Module

QUALIFICATION PROCESS

RESISTANCE TO PHYSICAL AND CHEMICAL STRESSES

- HTM226LF has passed through qualification processes of MEAS-FRANCE/HUMIREL including vibration, shock, storage, high temperature and humidity, ESD.
- Additional tests under harsh chemical conditions demonstrate good operation in presence of salt atmosphere, SO₂ (0.5%), H₂S (0.5%), O₃, NO_x, NO, CO, CO₂, Softener, Soap, Toluene, acids (H₂SO₄, HNO₃, HCl), HMDS, Insecticide, Cigarette smoke. This is not an exhaustive list.
- HTM226LF is not light sensitive.

QUALIFICATION PROCESS				
Test Item	Test Description and Conditions	Criteria	Results	
Drop Test	The samples are subjected to drop test, 6 times per direction (18 drops total) from 1 meter height onto concrete surface	<u>Visual</u> : No degradation or physical damage should be observed	PASS	
Vibration Test	The samples are subjected to variable frequency from 20 to 2000Hz in line with JESD-22-B103-A		PASS	
Thermal Cycling	The samples are subjected to thermal cycles from -20°C to +85°C during 168 hours		PASS	
High Temperature Storage Test	The samples are stored at +85°C for 1000 hrs		PASS	
Low Temperature Storage Test	The samples are stored at -20°C for 1000 hrs		PASS	
High Humidity and High Temperature Life Test	The samples are subjected to storage at +45°C and 90%RH conditions for 1000 hrs		<u>Electrical</u> : The variation of humidity detection output shall be within +/-5 %RH deviation (final - initial measurement)	PASS
Low Humidity Storage Test	The samples are subjected to low humidity storage condition at 20%RH, 25°C for 1000 hrs			PASS
Continuous Operation Test	The samples are subjected to continuous operation test with electric load of AC 5V(1 kHz) at ambient conditions for 1000 hrs			PASS
Thermal Shocks	The samples are subjected to 100 thermal shocks (Air - Air) between -40°C and +105°C. Dwell time is 1 hour with transition time to extreme temperature <5sec			PASS
ESD	The samples are subjected to ESD at +/-8kV by direct contact and air discharge			PASS

HTM226LF - Temperature and Humidity Module

PACKAGE OUTLINE

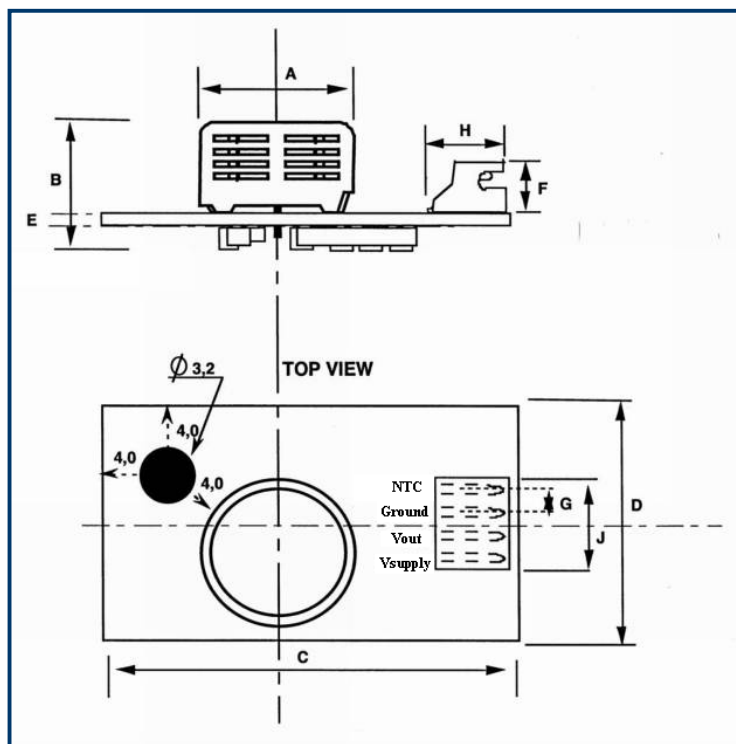

Dim	A	B	C	D	E	F	G	H	J	Φ
Min	9.7	8.5	28.0	14.5	1.5	3.5	1.45	4.8	7.3	3.0
Max	10.8	9.5	29.0	15.5	1.7	3.9	1.55	6.2	7.7	3.4

Dimensions in millimeters

HTM226LF - Temperature and Humidity Module

Revision	Comments	Who	Date
0	Document creation	B. SICARD	October 07
A	Product name modification and HPP number reference added	B. SICARD	October 07
B	Electrical characteristics updated, NTC LUT added, Qualification process paragraph added, Pinout assignment updated and Standardized datasheet format	D. LE GALL	October 08

The information in this sheet has been carefully reviewed and is believed to be accurate; however, no responsibility is assumed for inaccuracies. Furthermore, this information does not convey to the purchaser of such devices any license under the patent rights to the manufacturer. Measurement Specialties, Inc. reserves the right to make changes without further notice to any product herein. Measurement Specialties, Inc. makes no warranty, representation or guarantee regarding the suitability of its product for any particular purpose, nor does Measurement Specialties, Inc. assume any liability arising out of the application or use of any product or circuit and specifically disclaims any and all liability, including without limitation consequential or incidental damages. Typical parameters can and do vary in different applications. All operating parameters must be validated for each customer application by customer's technical experts. Measurement Specialties, Inc. does not convey any license under its patent rights nor the rights of others.