

# Installation Instructions for Standard and Extended Temperature Optomax Series Liquid Level Sensors

## GENERAL DESCRIPTION

The liquid level sensor provides single point liquid detection via a TTL compatible push pull output. An infra-red LED and phototransistor accurately positioned at the base of the sensing tip ensure good optical coupling between the two when the sensor is in air. When the sensing tip is immersed in liquid, the infra-red light escapes from the cone causing a change in the amount of light present at the phototransistor which makes the output change state.

## CLEANING

Proper fluids should be selected based on type of contamination to be removed. SST Sensing recommends freon and alcohol based solvents. DO NOT use chlorinated solvents such as trichloroethane as these are likely to attack the sensor material.

## Liquid Media Compatibility

Before use check that the fluid in which you wish to use these devices is compatible either with polysulphone or trogamid.

## ELECTRICAL SPECIFICATIONS

Supply Voltage (Vs)	+4.5 Vdc to +15.4Vdc	Output Voltage (Vout) Iout = 100mA	<b>Output High</b> Vout = Vs - 1V Max <b>Output Low</b> Vout = 0V + 0.5V Max
Supply Current (Is)	Max 2.5mA (Vs = 15.4Vdc)		
Output Type	An "L" in the part number after D3 indicates that the sensor output will be low in air. Otherwise the output will be high in air.	Output Voltage (Vout) Iout = 0mA	<b>Output High</b> Vout = Vs - 0.3V Max <b>Output Low</b> Vout = 0V + 0.1V Max
Output Sink and Source Current (Iout)	100mA		
Operating Temperatures	-25°C to +80°C (Standard) -40°C to +125°C (Extended)		
Storage Temperatures	-30°C to +85°C (Standard) -40°C to +125°C (Extended)		

## MOUNTING AND HOUSING TYPES

Housing Series	200 and 210 SH Series	500 and 510 Series	600 and 610 SH Series	700 and 710 SH Series
Thread	M12x1x8g with Hex Nut*	M10x1	½" SAE with O-Ring*	1/4" NPT
Tightening Torque	1.5 N m/13.26 in lb max.			
Pressure (when correctly sealed)	7 bar max	20 bar max	7 bar max	7 bar max
Mounting Hole	Ø12mm	Ø10mm	Ø ½ Inch	1/4" NPT Threaded
Housing Material	Polysulphone or Trogamid			
Sensor Termination	24AWG, 250mm PTFE Wires, 8mm Tinned			

\* Hex nut and o-ring sold separately, please contact us for details. NPT version can be sealed with PTFE tape.

## Sensor Output Wiring

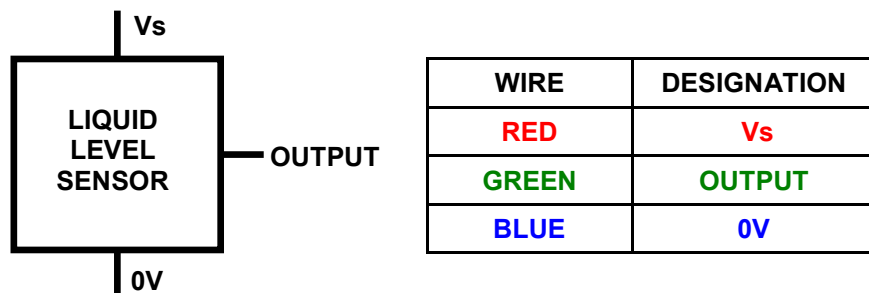

**PRODUCT DIMENSIONS**  
(All dimensions in mm)

**500 and 510 Series (Mounted from Inside)**

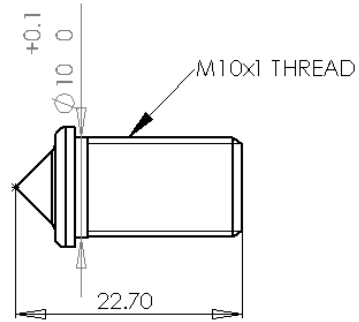
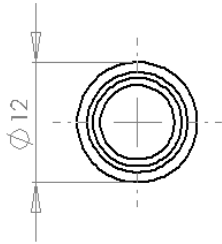

**200 and 210 SH Series (Mounted from Outside)**

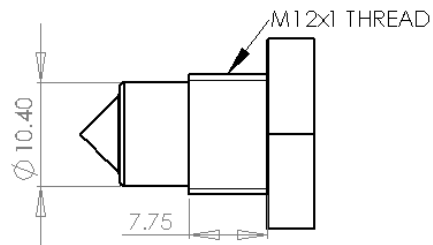
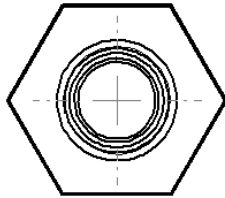

**600 and 610 SH Series (Mounted from Outside)**

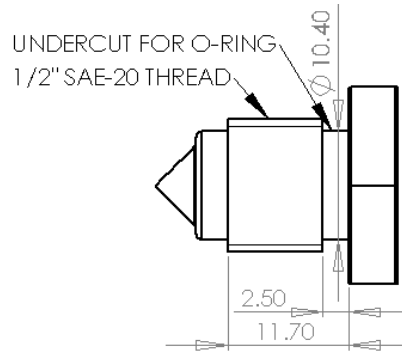
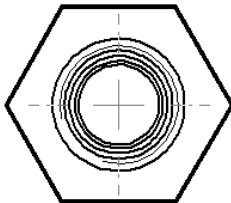

**700 and 710 SH Series (Mounted from Outside)**

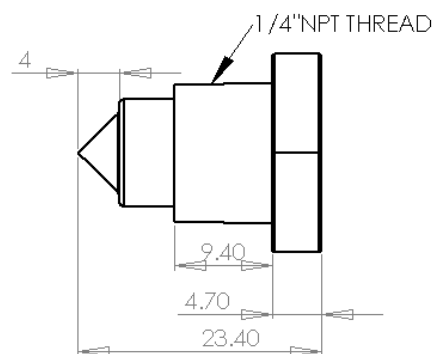
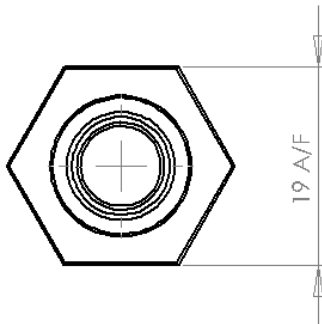

## PART NUMBERING SYSTEM

### SENSOR MOUNTED FROM INSIDE VESSEL

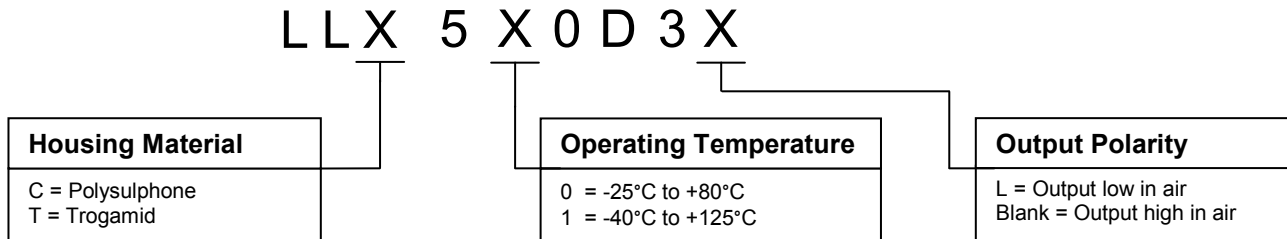

### SENSOR MOUNTED FROM OUTSIDE VESSEL

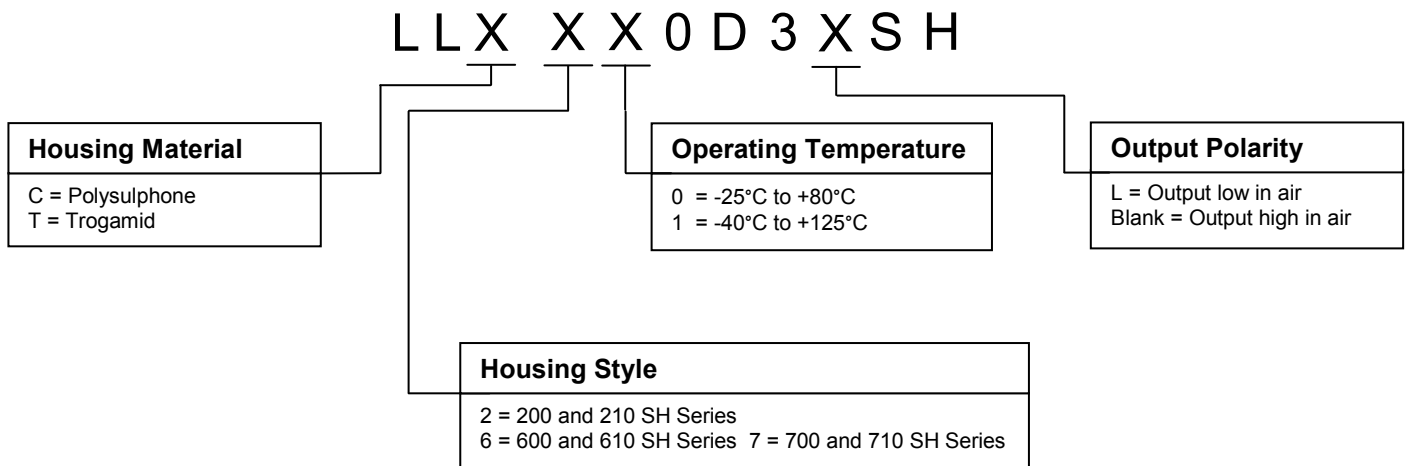

#### **WARNING**

##### **Personal Injury**

DO NOT USE these products as safety or Emergency Stop devices or in any other application where failure of the product could result in personal injury.

**Failure to comply with these instructions could result in death or serious injury.**

#### **CAUTION**

Do not exceed maximum ratings.

Although the sensor is protected against supply reversal, it is not recommended.

Do not overtighten screw-in type.

Do not use chlorinated solvents.

Do not mount with dome pointing downwards.

**Failure to comply with these instructions may result in product damage.**

**It is the customer's responsibility to ensure that this product is suitable for use in their application. For**