



# High Accuracy Low g Inertial Sensor

## MEMS Sensing, State Machine ASIC

The MMA690xKQ, a SafeAssure solution, is a dual axis, Low g, XY, Sensor based on Freescale's HARMEMS technology, with an embedded DSP ASIC, allowing for additional processing of the digital signals.

### Features

- Sensitivity in X and Y axes
- $\pm 3.5$  or  $\pm 5.0$ g full-scale range per axis
- AEC-Q100 qualified, Rev. F, grade 2 ( $-40 \leq T_A \leq 105^\circ\text{C}$ )
- 50 Hz second order low-pass filter
- Unsigned 11-bits digital data output
- SPI-compatible serial interface
- Capture/hold input for system-wide synchronization support
- 3.3 or 5.0V single supply operation
- On-chip temperature sensor and voltage regulator
- Bi-directional internal self-test
- Minimal external component requirements
- Pb-free 16-pin QFN package
- Pulse-code modulated output available for device evaluation

### Typical Applications

- With a  $\pm 3.5$ g or  $\pm 5.0$ g full scale range, the newly designed, high accuracy sensor, enables Electronic Stability Control (ESC) designers to accommodate higher original signal noise level without sacrificing resolution.
- Tilt Measurement
- Electronic Parking Brake

### ORDERING INFORMATION

Device Name	Range	Shipping
MMA6900KQ	$\pm 3.5$ g	Tubes
MMA6901KQ	$\pm 5.0$ g	
MMA6900KQR2	$\pm 3.5$ g	Tape and Reel
MMA6901KQR2	$\pm 5.0$ g	

## MMA690xKQ

### DUAL AXIS SPI INERTIAL SENSOR

### Bottom View

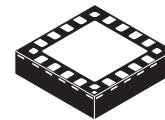

**16-PIN QFN**  
**98ASA10571D**  
**CASE 1477-02**

### Top View

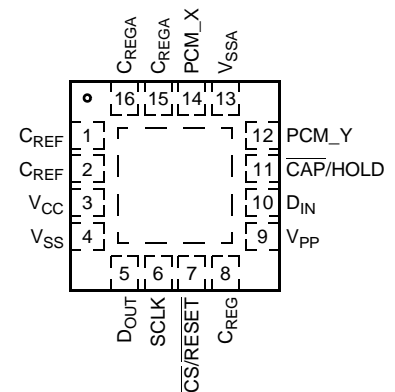

### PIN CONNECTIONS

## SECTION 1 INTRODUCTION

### 1.1 INTRODUCTION

MMA690xKQ is a two-axis member of Freescale's family of SPI-compatible accelerometers. These devices incorporate digital signal processing for filtering, trim, and data formatting.

### 1.2 SERIAL COMMUNICATION CONFIGURATION

The serial communication configuration provides a 4-wire SPI interface. Device serial number, acceleration range, filter characteristics, and status information are available along with acceleration data via the SPI.

### 1.3 BLOCK DIAGRAM

A block diagram illustrating the major components of the design is shown in [Figure 1-1](#).

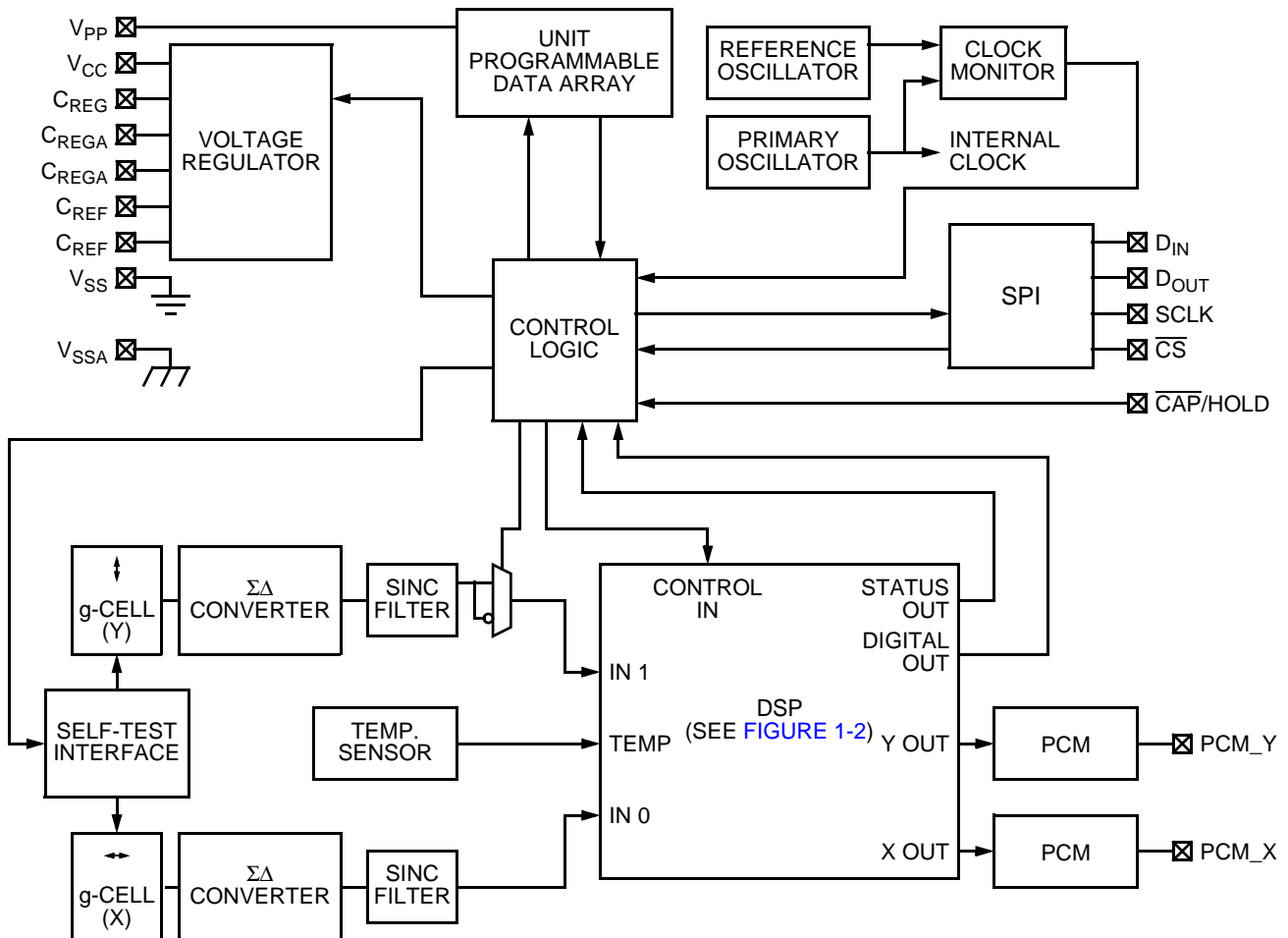

Figure 1-1 Block Diagram

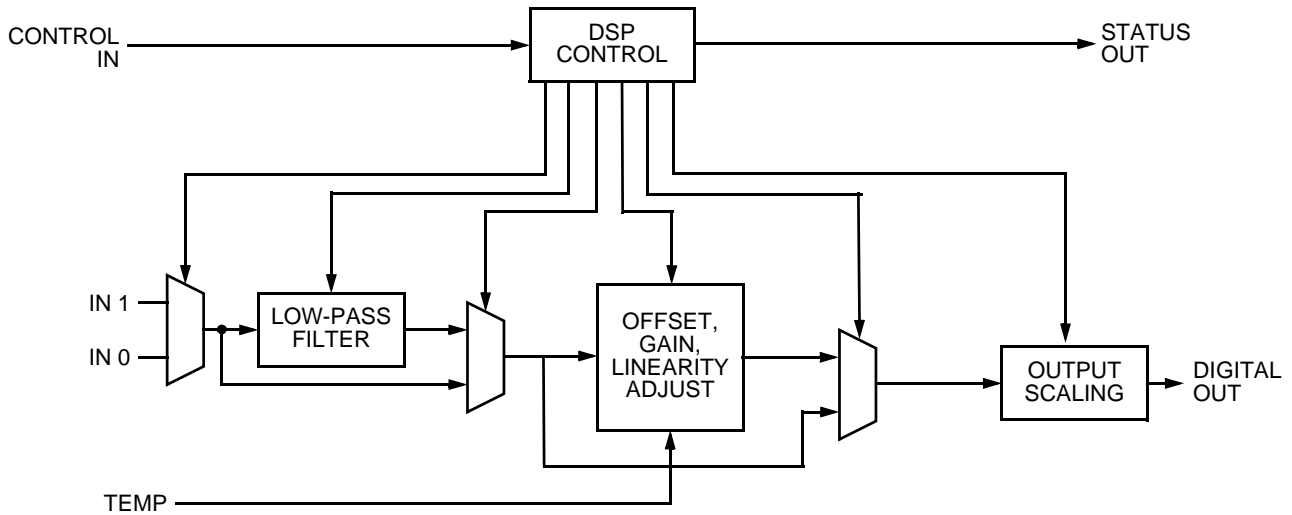

Figure 1-2 DSP Block Diagram

### 1.4 PIN FUNCTIONS

The pinout is illustrated in Figure 1-3. Pin functions are described in the following paragraphs. When self-test is active, the output becomes more positive in both axes, if ST1 is cleared or more negative in both axes if ST1 is set, as described in Section 2.1.3.

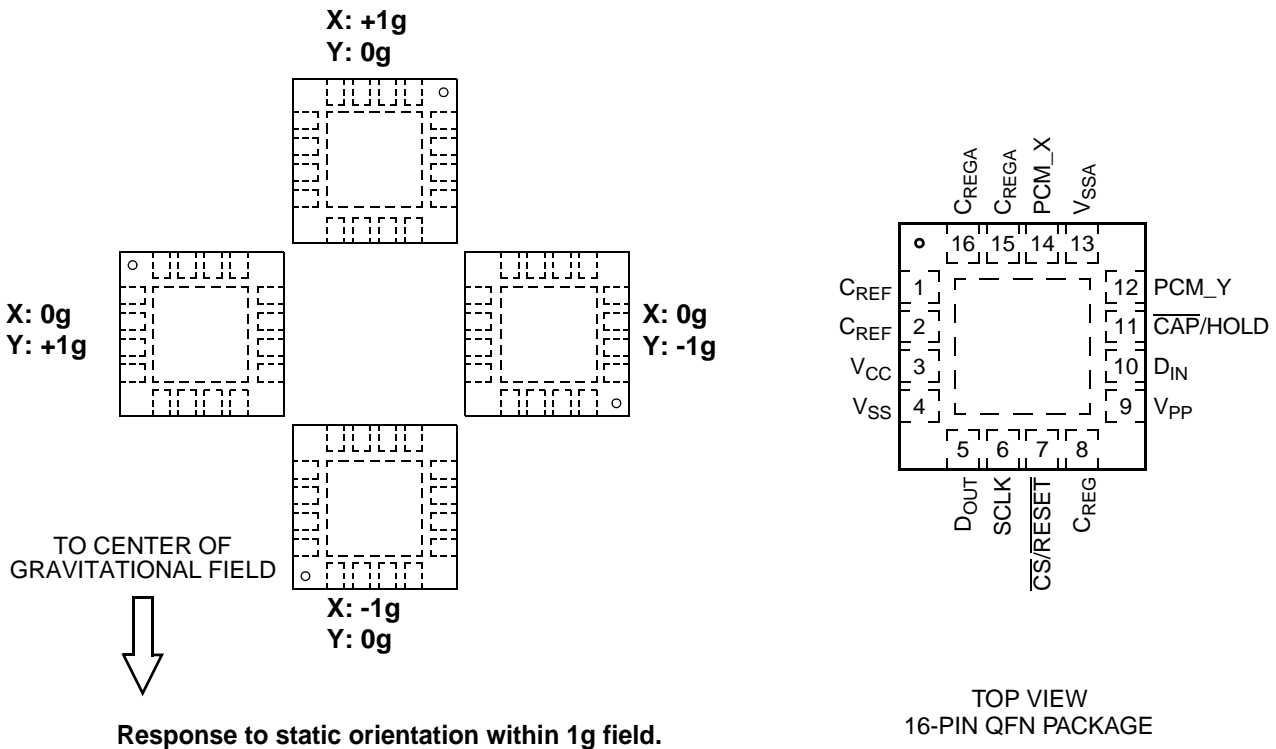

Figure 1-3 Pinout for MMA690xKQ

#### 1.4.1 V<sub>CC</sub>

This pin supplies power to the device. Careful printed wiring board layout and capacitor placement is critical to ensure best performance. An external bypass capacitor between this pin and V<sub>SS</sub> is required, as described in [Section 1.5](#).

#### 1.4.2 V<sub>SS</sub>

This pin is the power supply return node for the digital circuitry on the MMA690xKQ device.

#### 1.4.3 V<sub>SSA</sub>

This pin is the power supply return node for analog circuitry on the MMA690xKQ device. An external bypass capacitor between this pin and V<sub>CC</sub> is required, as described in [Section 1.5](#).

#### 1.4.4 C<sub>REG</sub>

This pin is connected to the internal digital circuitry power supply rail. An external filter capacitor must be connected between this pin and V<sub>SS</sub>, as described in [Section 1.5](#).

#### 1.4.5 C<sub>REGA</sub>

These pins are connected in parallel to the internal analog circuitry power supply rail. One or two external filter capacitors must be connected between these pins and V<sub>SSA</sub>, as described in [Section 1.5](#). Two pins are provided to support redundant connection to the printed wiring board assembly. Redundant external capacitors may be connected to these pins for maximum reliability, as described in [Section 1.5](#).

#### 1.4.6 C<sub>REF</sub>

These pins are connected in parallel to an internal reference voltage node utilized by the analog circuitry. One or two external filter capacitors must be connected between these pins and V<sub>SSA</sub>, as described shown in [Section 1.5](#). Two pins are provided to support redundant connection to the printed wiring board assembly. Redundant external capacitors may be connected to these pins for maximum reliability, as described in [Section 1.5](#).

#### 1.4.7 V<sub>PP</sub>

This pin should be tied directly to V<sub>SS</sub>. An internal pull-down device is connected to this pin to reduce the risk of unpredictable device operation in the event that the connection to V<sub>SS</sub> opens.

#### 1.4.8 SCLK

This input pin provides the serial clock to the SPI port. The state of this pin is also used as a qualifier for externally-controlled reset. This input may be used to initiate device reset as described in [Section 1.4.9](#) and [Section 2.6](#). An internal pull-down device is connected to this pin.

#### 1.4.9 $\overline{\text{CS/RESET}}$

This pin functions as the chip select input for the SPI port. The state of the D<sub>IN</sub> pin during low-to-high transitions of SCLK is latched internally and D<sub>OUT</sub> is enabled when  $\overline{\text{CS}}$  is at a logic low level.

This pin may also be used to initiate a hardware reset. If  $\overline{\text{CS}}$  is held low and SCLK is held high for 512  $\mu\text{s}$ , the internal reset signal is asserted. This behavior is described in [Section 2.6](#).

An internal pull-up device is connected to this pin.

#### 1.4.10 D<sub>OUT</sub>

This pin functions as the serial data output for the SPI port. SPI data transmitted on D<sub>OUT</sub> will have an odd number of logic '1' bits set during normal 16-bit transfer, unless an internal oscillator fault condition has been detected. If an internal oscillator fault condition is present, D<sub>OUT</sub> is driven to a logic high level continuously when  $\overline{\text{CS/RESET}}$  is asserted.

#### 1.4.11 D<sub>IN</sub>

This pin functions as the serial data input to the SPI port. An internal pull-down device is connected to this pin. SPI data received at D<sub>IN</sub> must observe odd parity or a transient exception condition will be reported during the subsequent transfer.

#### 1.4.12 $\overline{\text{CAP/HOLD}}$

When this input pin is low, the SPI acceleration result registers are updated by the DSP whenever a data sample becomes available. Upon a low-to-high transition of  $\overline{\text{CAP/HOLD}}$ , the contents of the acceleration result registers are frozen. The result registers will not be updated so long as this pin remains at a logic '1' level. This pin may be tied directly to V<sub>SS</sub> if the hold function is not desired.

### MMA690xKQ

An internal pulldown device is connected to this pin, however it is recommended that CAP/HOLD either be driven by a logic output or tied to  $V_{SS}$  in application circuits. If CAP/HOLD is at logic level '1' during initial startup and through the release of internal reset, the result register will be 0 counts, which is a reserved result, and should be discarded by the application. This state is exited by the next high-to-low transition of CAP/HOLD.

#### 1.4.13 PCM\_X, PCM\_Y

MMA690xKQ provides the option for a Pulse Code Modulated (PCM) output function. The PCM output is activated when PCM\_EN is set in the DEVCTL register. When the PCM function is enabled, the upper nine bits of the 11-bit scaled acceleration values are used to generate PCM signals proportional to incident respective acceleration, at 250 ns resolution. A simplified block diagram of the PCM output is shown in Figure 1-4.

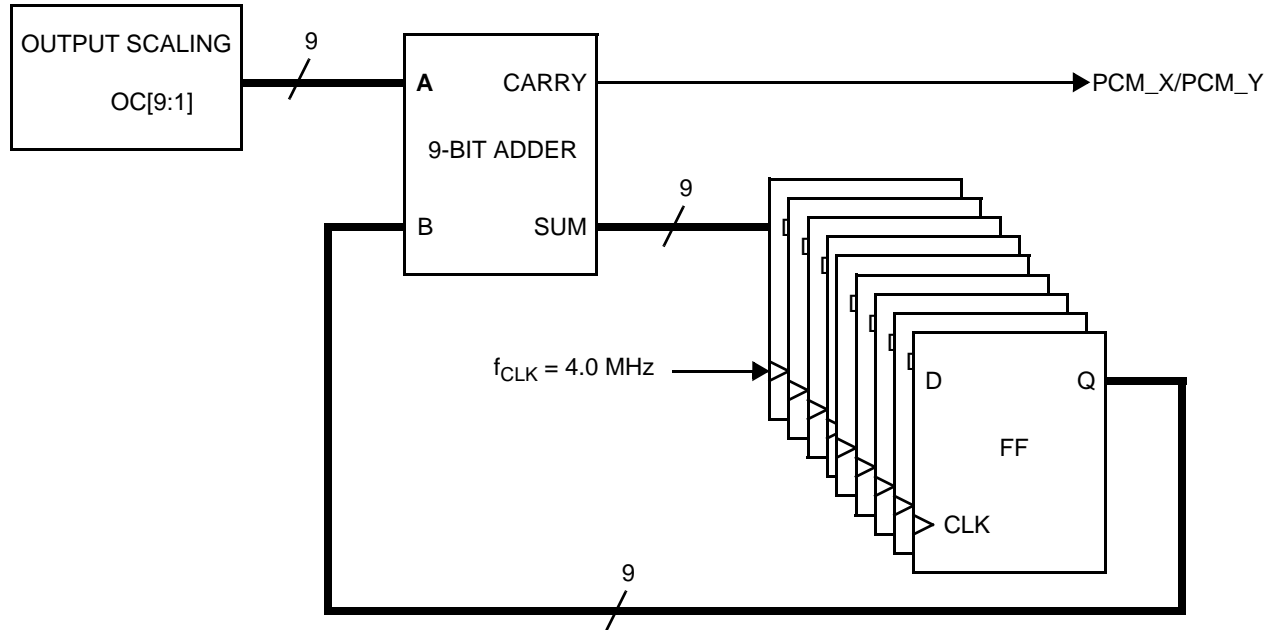
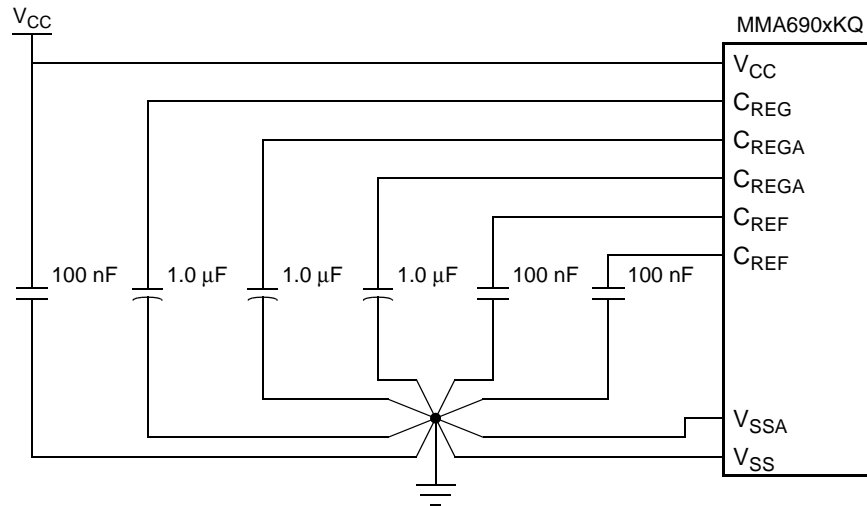

Figure 1-4 PCM Output Function Block Diagram

## 1.5 EXTERNAL COMPONENTS

The connections illustrated in Figure 1-5 are recommended. Careful printed wiring board layout and component placement is essential for best performance. Low ESR capacitors must be connected to  $C_{REG}$  and  $C_{REGA}$  pins for best performance. A grounded land area with solder mask should be placed under the package for improved shielding of the device from external effects. If a land area is not provided, no signals should be routed beneath the package.



RECOMMENDED EXTERNAL COMPONENT CONFIGURATION

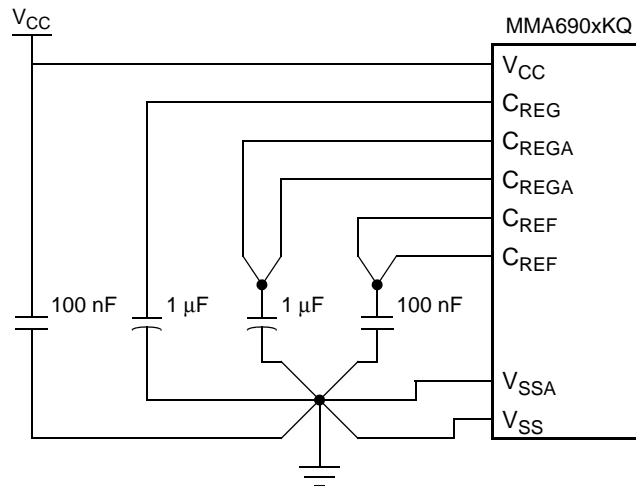

ALTERNATE EXTERNAL COMPONENT CONFIGURATION

Figure 1-5 External Components

## SECTION 2 INTERNAL MODULES

### 2.1 DATA ARRAY

A 400-bit data array allows each device to be customized. The array interface incorporates parity circuitry for fault detection along with a locking mechanism, to prevent unintended changes. Portions of the array are reserved for factory-programmed trim values. Customer accessible data stored in the array are shown in the [Table 2-1](#).

Addresses \$00 - \$0D are associated with the data array. A writable register at address \$0E is provided for device control operations. Two read-only registers at addresses \$0F and \$10 provide status information.

Unused bits within the data array are always read as '0' values. Unprogrammed OTP bits are also read as '0' values.

**Table 2-1. DSP Configuration Register**

Location		Bit Function								Type
Addr	Register	7	6	5	4	3	2	1	0	
\$00	SN0	SN[7]	SN[6]	SN[5]	SN[4]	SN[3]	SN[2]	SN[1]	SN[0]	F/R
\$01	SN1	SN[15]	SN[14]	SN[13]	SN[12]	SN[11]	SN[10]	SN[9]	SN[8]	
\$02	SN2	SN[23]	SN[22]	SN[21]	SN[20]	SN[19]	SN[18]	SN[17]	SN[16]	
\$03	SN3	SN[31]	SN[30]	SN[29]	SN[28]	SN[27]	SN[26]	SN[25]	SN[24]	
\$04	DEVCFG0	0	0	0	0	RNG[3]	RNG[2]	RNG[1]	RNG[0]	F/R
\$05	DEVCFG1	0	0	0	0	RNG[3]	RNG[2]	RNG[1]	RNG[0]	
\$06	DEVCFG2	0	0	0	0	0	0	0	0	
\$07	DEVCFG3	0	0	0	0	0	0	0	0	
\$08	DEVCFG4	0	0	0	0	0	0	0	0	
\$09	DEVCFG5	1	0	1	0	0	0	0	0	
\$0A	AXCFG_X	1	0	0	1	0	1	0	1	F/R
\$0B	AXCFG_Y	1	0	0	1	0	1	0	1	
\$0C	Unused								N/A	
\$0D	DSPCFG	0	0	1	0	0	1	0	0	F/R
\$0E	DEVCTL	RES_1	RES_0	CE	PCM_EN	HPFB	YINV	ST1	ST0	R/W
\$0F	TEMP	TEMP[7]	TEMP[6]	TEMP[5]	TEMP[4]	TEMP[3]	TEMP[2]	TEMP[1]	TEMP[0]	R
\$10	DEVSTAT	IDE	OSCF	DEVINIT	TF	0	0	0	DEVRES	
\$11	COUNT	COUNT[7]	COUNT[6]	COUNT[5]	COUNT[4]	COUNT[3]	COUNT[2]	COUNT[1]	COUNT[0]	
\$24	ACC_X11L	ACC_X[7]	ACC_X[6]	ACC_X[5]	ACC_X[4]	ACC_X[3]	ACC_X[2]	ACC_X[1]	ACC_X[0]	
\$25	ACC_X11H	0	0	0	0	0	ACC_X[10]	ACC_X[9]	ACC_X[8]	
\$26	ACC_Y11L	ACC_Y[7]	ACC_Y[6]	ACC_Y[5]	ACC_Y[4]	ACC_Y[3]	ACC_Y[2]	ACC_Y[1]	ACC_Y[0]	
\$27	ACC_Y11H	0	0	0	0	0	ACC_Y[10]	ACC_Y[9]	ACC_Y[8]	

F: Factory programmed OTP location    R: Read-only register    R/W: Read/write register    N/A: Not applicable

### 2.1.1 Device Serial Number

A unique serial number is programmed into each device during manufacturing. The serial number is composed of the following information.

**Table 2-2. Serial Number Assignment**

Bit Function	
Bit Range	Content
SN12 - SN0	Serial Number
SN31 - SN13	Lot Number

Lot numbers begin at 1 for all devices produced and are sequentially assigned. Serial numbers begin at 1 for each lot, and are sequentially assigned. No lot will contain more devices than can be uniquely identified by the 13-bit serial number. Not all allowable lot numbers and serial numbers will be assigned.

### 2.1.2 Full-Scale Range

Full-scale range is indicated by the value programmed into DEVCFG0 and DEVCFG1. Ranges for defined part numbers are shown in Table 2-3 below.

**Table 2-3. Full-Scale Range**

Part Number	Register	Range Bits				Full-Scale Range (g)
		RNG[3]	RNG[2]	RNG[1]	RNG[0]	
MMA6900KQ	DEVCFG0	0	0	0	0	3.5
	DEVCFG1	0	0	0	0	3.5
MMA6901KQ	DEVCFG0	0	1	0	1	5.0
	DEVCFG1	0	1	0	1	5.0

### 2.1.3 Device Control Register (DEVCTL)

A read-write register at address \$0E supports a number of device control operations as described in the following. Reserved bits within DEVCTL are always read as logic '0' values.

Write operations involving DEVCTL are effective approximately 1.0  $\mu$ s following negation of  $\overline{\text{CS}}/\overline{\text{RESET}}$ . This delay must be considered if successive SPI operations involving write to DEVCTL followed by acceleration data read are conducted in the minimum allowed transfer timing, as the acceleration result may indicate lingering self-test or error status conditions. It is therefore recommended that acceleration data read operations be delayed by at least 1.2  $\mu$ s following writes to DEVCTL.

**Table 2-4. Device Control Register**

Address	Register	Bit							
		7	6	5	4	3	2	1	0
\$0E	DEVCTL	RES1	RES0	CE	PCM_EN	HPFB	YINV	ST1	ST0

#### 2.1.3.1 Reset Control (RES\_1, RES\_0)

A specific series of three write operations involving these two bits will cause the internal digital circuitry to be reset. The state of the remaining bits in the DEVCTL register do not affect the reset sequence, however any write operation involving this register in which both RES\_1 and RES\_0 are cleared will terminate the sequence.

To reset the internal digital circuitry, the following register write operations must be performed in the order shown:

1. Set RES1. RES0 must remain cleared.
2. Set RES1 and RES0.
3. Clear RES1 and set RES0.

RES1 and RES0 are always read as logic '0' values.



### 2.1.3.2 Clear Error (CE)

Setting this bit to a logic '1' state will clear transient error status conditions. It is necessary to either set this bit or perform a device reset if an error condition has been reported by the device before acceleration data transfer can be resumed. The device reset condition may be cleared only after device initialization has completed.

Error conditions and classification are described in [Section 3.1](#).

The state of this bit is always read as logic '0'.

### 2.1.3.3 PCM Enable (PCM\_EN)

This bit controls the PCM\_X and PCM\_Y outputs along with internal circuitry which generates a pulse-code modulated signal from the acceleration result. When this bit is set, the PCM outputs are enabled. When cleared, PCM\_X and PCM\_Y are driven to a logic low level.

### 2.1.3.4 High-pass Filter Bypass (HPFB)

The high-pass filter is disabled through factory settings, therefore writing this bit will have no effect. If read, this bit will be "0".

### 2.1.3.5 Y-Axis Signal Inversion Control (YINV)

This control function is provided as a means to verify operation of the two-channel multiplexor which alternately provides X-axis and Y-axis data to the DSP. An inverter block and multiplexor at the Y-axis input to the DSP are controlled by the YINV bit. Setting this bit when ST0 is set has the effect of changing the sign of acceleration in the Y-axis. Operation of the YINV bit is illustrated in [Figure 2-1](#). Y-axis inversion may be selected only during self-test; the state of this bit has no effect when ST0 is cleared.

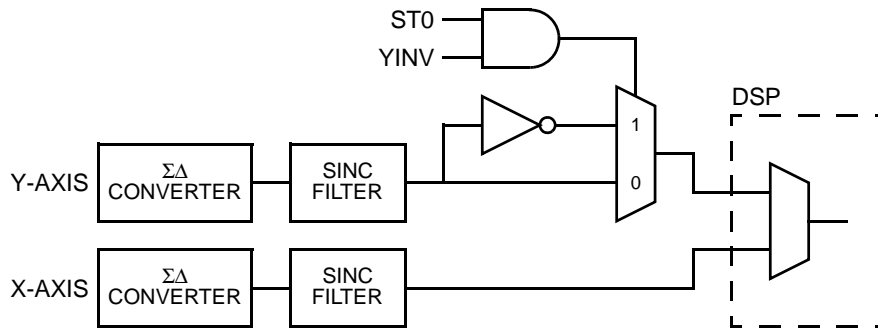

Figure 2-1 Y-Axis Inversion Function

Self-test operations controlled by YINV along with ST1 and ST0 are summarized in the [Table 2-5](#).

### 2.1.3.6 Self-test Control (ST1, ST0)

Bidirectional self-test control is provided through manipulation of these bits. ST1 controls direction while ST0 enables and disables the self-test circuitry. ST1 and ST0 are always cleared following internal reset. When ST0 is set, the high-pass filter is bypassed and the values within the high-pass filter are frozen. Both axes are affected simultaneously by the state of these bits. If the offset monitor is enabled, self-test activation in a single direction should be limited to less than 30 ms.

Communications Protocol bits S2 - S1 are inverted when self-test is activated, as described in [Section 3.2](#).

Table 2-5. Self-Test Control Operations

YINV	ST1	ST0	Self-Test Operation	
			X-Axis	Y-Axis
X	X	0	Self-test Disabled, Y-Axis Signal Inversion Disabled	
0	0	1	Positive Deflection	
0	1	1	Negative Deflection	
1	0	1	Positive Deflection	Negative Deflection
1	1	1	Negative Deflection	Positive Deflection

Offset correction is applied within the DSP, and is not affected by the state of the YINV bit. Consequently, inversion of the Y-axis signal may result in saturation of the Y-axis output value.

Correct operation of the DSP input multiplexor may be confirmed by performing the operations shown in [Figure 2-2](#).

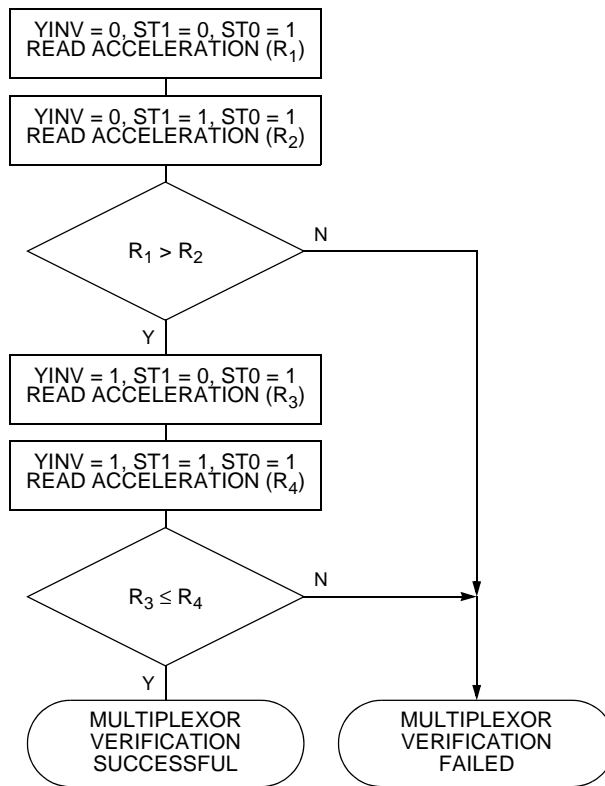

Figure 2-2 DSP Input Multiplexer Verification Flow Chart (Y Axis)

### 2.1.4 Temperature Sensor Value (TEMP)

This read-only register contains a signed value which provides a relative temperature indication. The temperature sensor is uncalibrated and its output for a given temperature will vary from one device to the next. The value in this register increases with temperature.

Table 2-6. Temperature Sensor Value Register

Location		Bit Function							
Address	Register	7	6	5	4	3	2	1	0
\$0F	TEMP	TEMP[7]	TEMP[6]	TEMP[5]	TEMP[4]	TEMP[3]	TEMP[2]	TEMP[1]	TEMP[0]

### 2.1.5 Device Status Register (DEVSTAT)

This read-only register is accessible in all modes.

Table 2-7. Device Status Register

Location		Bit Function							
Address	Register	7	6	5	4	3	2	1	0
\$10	DEVSTAT	IDE	0	DEVINIT	TF	0	0	0	DEVRES

#### 2.1.5.1 Internal Data Error Flag (IDE)

This flag will be set if a register data parity fault or a marginally programmed fuse is detected. Device reset is required to clear this fault condition. If a parity error is associated with the data stored in the fuse array, this fault condition cannot be cleared. This flag is disabled when the device is in test mode.

#### 2.1.5.2 Device Initialization Flag (DEVINIT)

This flag is set during the interval between negation of internal reset and completion of device initialization. DEVINIT is cleared automatically.

### 2.1.5.3 Temperature Fault Flag (TF)

This flag is set if the value reported by the on-chip temperature sensor exceeds specified limits. TF may be cleared by writing a logic '1' value to the CE bit in DEVCTL, provided that the fault condition is no longer detected.

### 2.1.5.4 Device Reset Flag (DEVRES)

This flag is set during device initialization. A logic '1' must be written to the CE bit in the Device Control register (DEVCTL) to clear this bit. Except when Communications Protocol is active, this bit must be explicitly cleared following reset before acceleration results can be read from MMA690xKQ.

### 2.1.6 Counter Register (COUNT)

This read-only register provides the value of a free-running 8-bit counter derived from the primary oscillator. A five-bit prescaler divides the 4.0 MHz primary oscillator frequency by 32. Thus, the value in the register increases by one count every 8.0  $\mu$ s, and the counter rolls over every 2.048 ms.

**Table 2-8 Counter Register**

Location		Bit Function							
Address	Register	7	6	5	4	3	2	1	0
\$11	COUNT	COUNT[7]	COUNT[6]	COUNT[5]	COUNT[4]	COUNT[3]	COUNT[2]	COUNT[1]	COUNT[0]

### 2.1.7 Acceleration Result Registers

These read-only registers contain acceleration results produced by the DSP. The values in these registers are frozen by either of two events:

- $\overline{\text{CAP}}/\text{HOLD}$  input at logic high level
- $\overline{\text{CS}}$  input at logic low level

Acceleration result registers are provided for each axis. ACC\_X11L/ACC\_X11H and ACC\_Y11L/ACC\_Y11H provide 11-bit results. Updates to ACC\_X11L/ACC\_X11H and ACC\_Y11L/ACC\_Y11H are halted upon reading the lower-byte register of either pair until the upper-byte register is read. There is no requirement to manipulate  $\overline{\text{CAP}}/\text{HOLD}$  when reading ACC\_X11L/ACC\_X11H or ACC\_Y11L/ACC\_Y11H, however ACC\_X11H or ACC\_Y11H must be read after reading ACC\_X11L or ACC\_Y11L, respectively, or further updates to the register pair will not occur.

**Table 2-9. X-Axis Acceleration Result Registers**

Location		Bit Function							
Address	Register	7	6	5	4	3	2	1	0
\$24	ACC_X11L	ACC_X[7]	ACC_X[6]	ACC_X[5]	ACC_X[4]	ACC_X[3]	ACC_X[2]	ACC_X[1]	ACC_X[0]
\$25	ACC_X11H	0	0	0	0	0	ACC_X[10]	ACC_X[9]	ACC_X[8]

**Table 2-10. Y-Axis Acceleration Result Registers**

Location		Bit Function							
Address	Register	7	6	5	4	3	2	1	0
\$26	ACC_Y11L	ACC_Y[7]	ACC_Y[6]	ACC_Y[5]	ACC_Y[4]	ACC_Y[3]	ACC_Y[2]	ACC_Y[1]	ACC_Y[0]
\$27	ACC_Y11H	0	0	0	0	0	ACC_Y[10]	ACC_Y[9]	ACC_Y[8]

Sign extension is applied to the upper five bits of ACC\_X11H and ACC\_Y11H. **If an error condition exists, the reserved value 0 will be read in place of 11-bit acceleration data.**

## 2.2 VOLTAGE REGULATORS

Separate internal voltage regulators supply fixed voltages to the analog and digital circuitry. External filter capacitors are required, as shown in Figure 1-5.

The voltage regulator module includes a voltage monitoring circuitry which holds the device in reset following power-on until internal voltages have stabilized sufficiently for proper operation. The voltage monitor asserts internal reset when the external supply or internally regulated voltages fall below predetermined levels.

A reference generator provides a stable voltage which is used by the  $\Sigma\Delta$  converter. This circuit also requires an external filter capacitor.

The voltage regulator module is illustrated in Figure 2-3 and Figure 2-4.

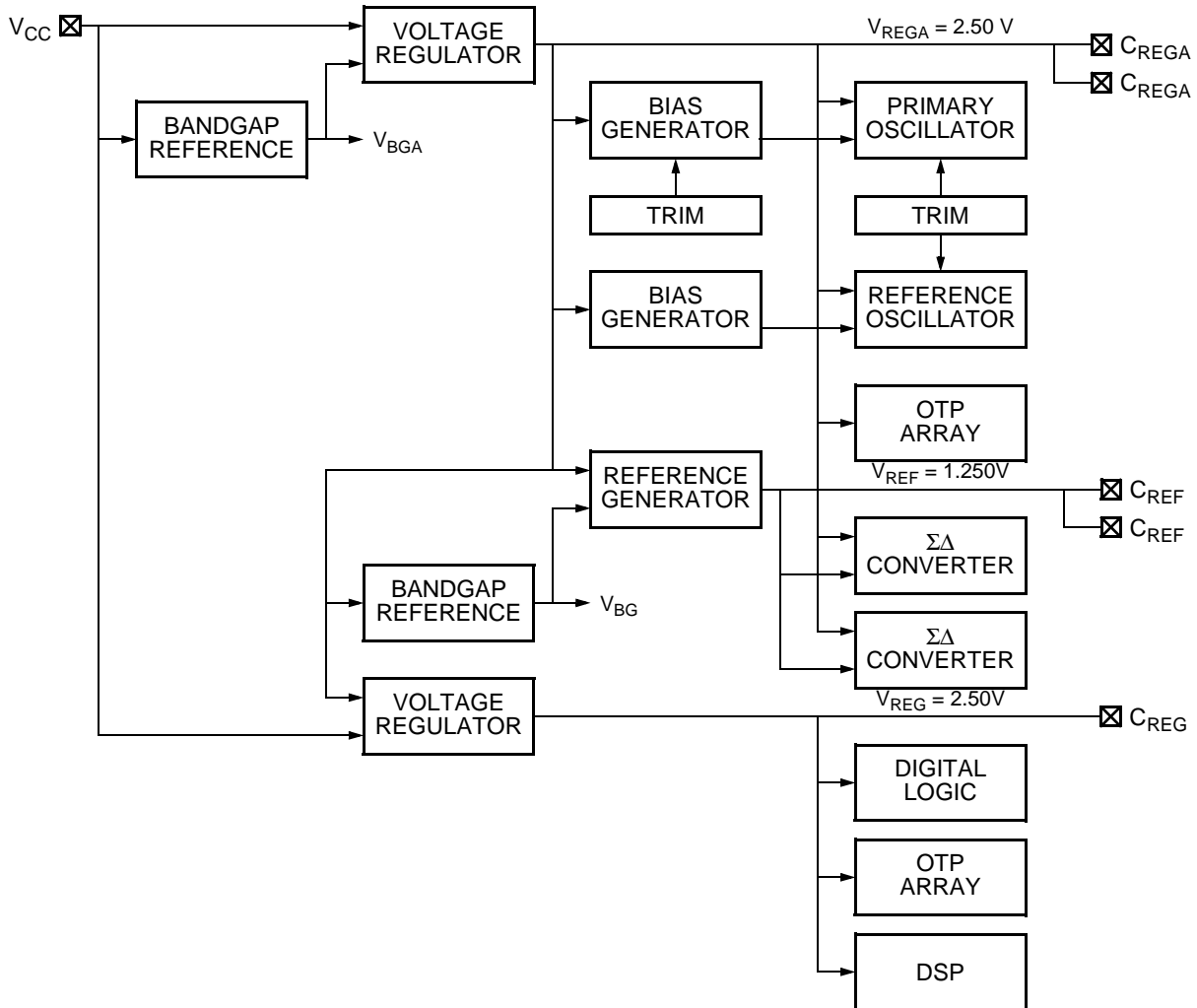

Figure 2-3 Power Distribution

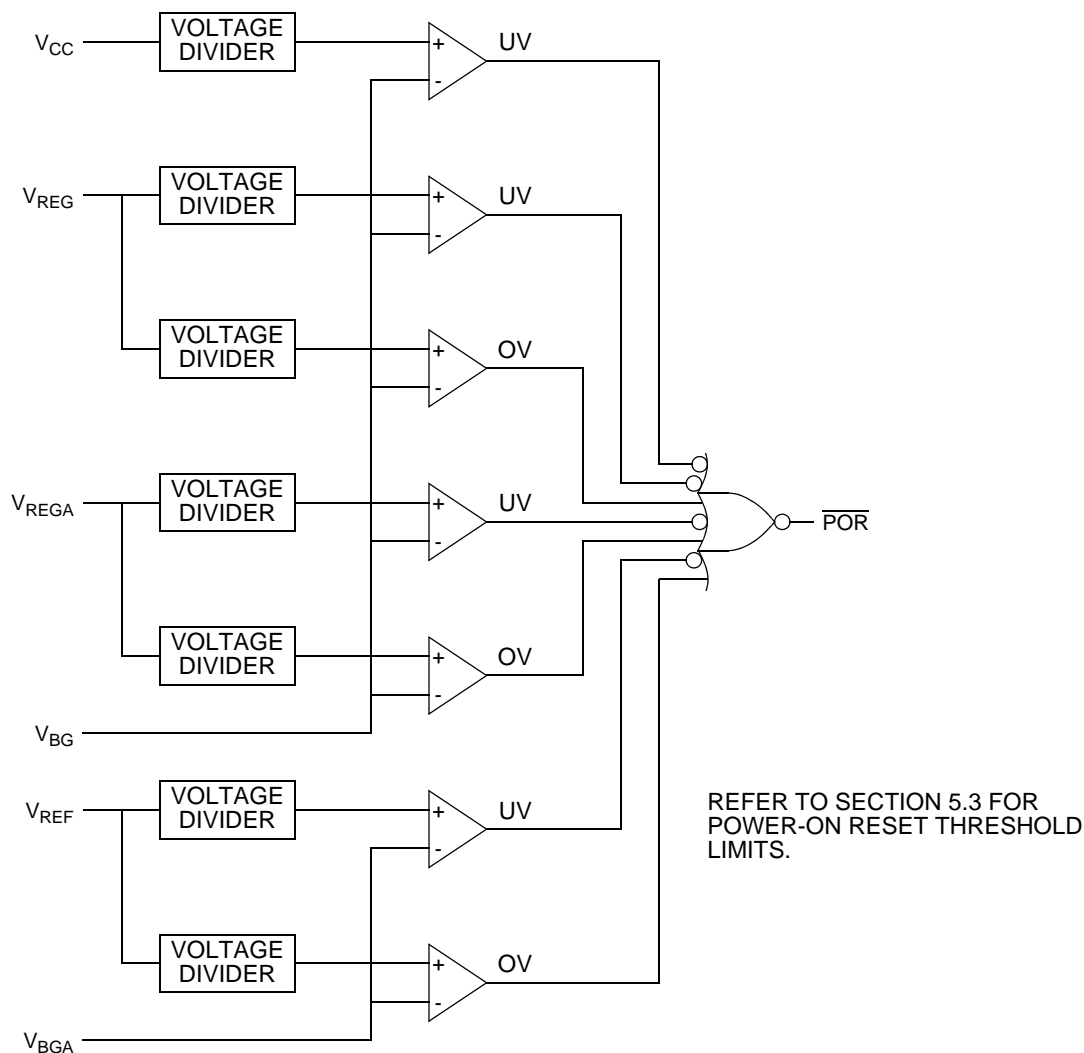

Figure 2-4 Voltage Monitoring

## 2.3 OSCILLATOR

An internal oscillator operating at a nominal frequency of 4.0 MHz provides a stable clock source. The oscillator is factory trimmed for best performance. A clock generator block divides the 4.0 MHz clock as needed by other blocks.

## 2.4 C<sub>REG</sub> MONITOR

A monitor circuit is incorporated to ensure predictable operation of the device in the event that the connection to the external capacitor at the C<sub>REG</sub> pin (pin 8) fails, or the capacitor opens. The monitor disables the 2.5 V regulator which powers the digital circuitry for 2.0  $\mu$ s every 249.5  $\mu$ s. If the external capacitor is not present, voltage at the internal supply rail will drop below the internal reset threshold, continuously forcing the device into reset. Loss of communication from the device is a readily detectable condition. The X<sub>OUT</sub> and Y<sub>OUT</sub> pins are driven to the low rail when the device is in the reset state.

## 2.5 CLOCK MONITOR

Two independent oscillators are provided within MMA690xKQ. One is factory-trimmed and provides the timing reference used throughout the device. The second oscillator acts as a reference for the first. If the frequency of these two oscillators varies by more than 10%, an oscillator fault condition is determined. In normal operating mode, an oscillator fault will cause the D<sub>OUT</sub> pin to be forced to a continuous logic high state when CS is asserted, as described in [Section 3.1.1.2](#).

## 2.6 INTERNAL RESET CONTROLLER

Four conditions can result in an internal reset. The initial power-on condition always results in a reset condition. An internal voltage monitor will assert reset when the supply voltage or a regulated output voltage falls below specified limits. This is referred to as a low voltage reset. Externally, a hardware reset can be initiated by holding SCLK high and driving the CS pin low for 512  $\mu$ s. Finally, the device can be reset through a series of register write operations, as described in [Section 2.1.3.1](#).

## 2.7 CONTROL LOGIC

A control logic block coordinates a number of activities within the device. These include:

- Post-reset device initialization
- Self-test
- Operating mode selection
- Data array programming
- Device support data transfers

## 2.8 TEMPERATURE SENSOR

A temperature sensor provides input to the digital signal processing block. Device temperature is incorporated into a correction value, which is applied to each acceleration result. The upper eight bits of the temperature sensor value are accessible through the TEMP register, described in [Section 2.1.4](#). The temperature sensor output is continuously compared to under- or over-temperature limits of approximately -40 and +110 °C, respectively. A temperature fault condition is indicated if the temperature sensor value exceeds the under- or over-temperature limit.

### 2.8.1 TEMPERATURE SENSOR MONITOR

A monitor circuit associated with the temperature sensor is provided. The monitor will detect over- or under-temperature conditions as well as rapid fluctuations in temperature sensor output such as would be related to failure of the sensor. If a temperature related fault is detected, an error condition is indicated in lieu of acceleration data.

Rapid fluctuation of the temperature sensor output is detected by comparing the value of each sample to the previous value. This operation, as well as temperature limit detection is illustrated in [Figure 2-5](#). A fault condition is indicated if predetermined limits are exceeded.

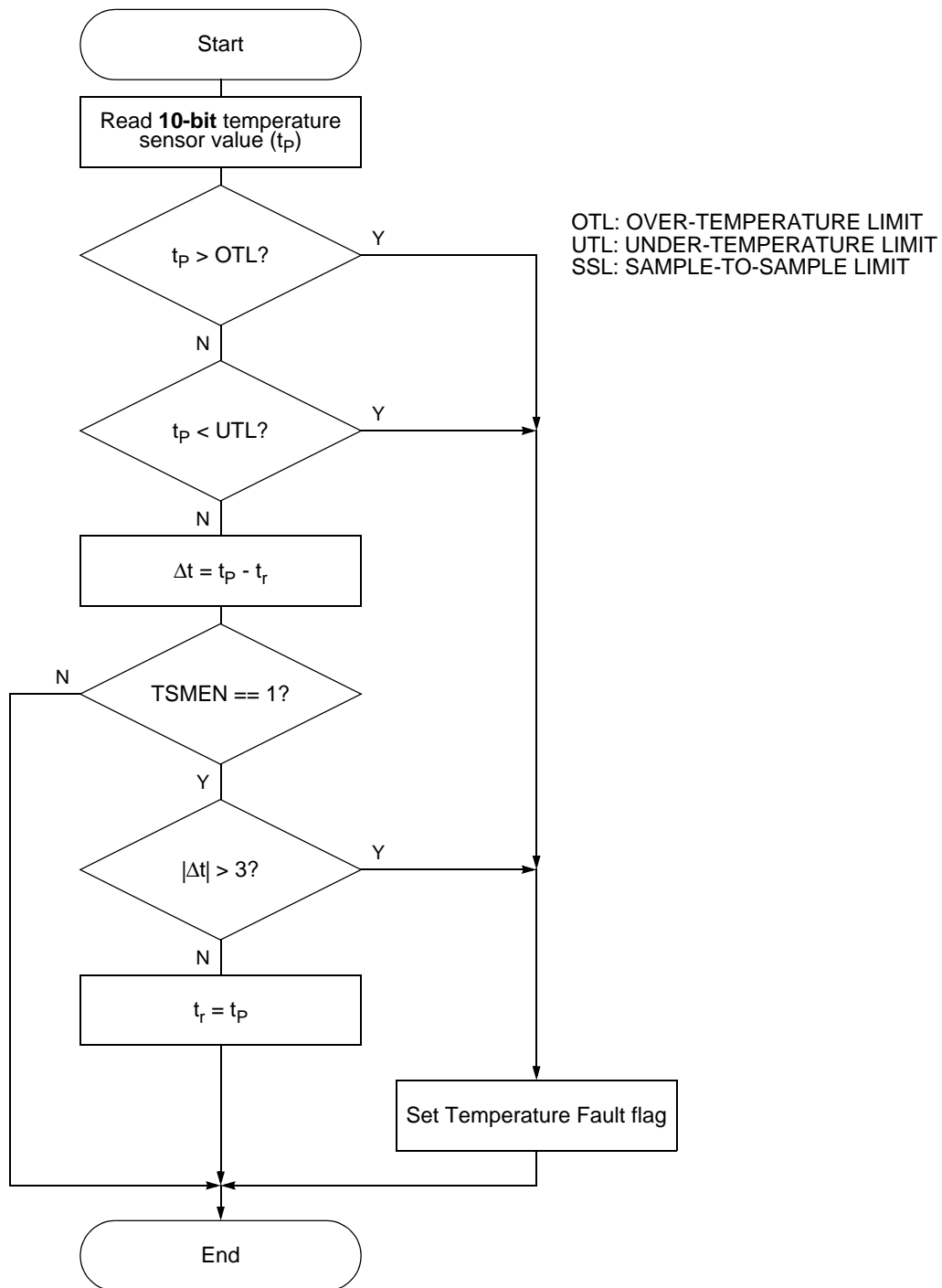

Figure 2-5 Temperature Sensor Monitor Flow Chart

## 2.9 SPI

The SPI is a full bidirectional port which is used for all configuration and control functions.

## 2.10 SELF-TEST INTERFACE

The self-test interface provides a mechanism for applying a calibrated voltage to the g-cell. This results in deflection of the proof mass, causing reported acceleration results to be offset by a specified amount. Control of the self-test interface via the SPI is accommodated through write operations involving the DEVCTL register at address \$0E, described in [Section 2.1.3](#).

## 2.11 $\Sigma\Delta$ CONVERTERS

Two sigma delta converters provide the interface between the g-cell and digital signal processing block. The output of each  $\Sigma\Delta$  converter is a data stream at a nominal frequency of 1.0 MHz.

## 2.12 DIGITAL SIGNAL PROCESSING BLOCK

A Digital Signal Processing (DSP) block is used to perform all filtering and correction operations. A diagram illustrating the signal processing flow within the DSP block is shown in [Figure 1-1](#). The DSP operates at 2.0 MHz, twice the frequency of the  $\Sigma\Delta$  converters. The two interleaved bit streams from the  $\Sigma\Delta$  converters are processed simultaneously within the DSP.

Each MMA690xKQ device is factory programmed to select the acceleration range. Filter characteristics for the X- and Y-axes are customer programmed.

### 2.12.1 LOW-PASS FILTER

Low-pass filtering occurs in two stages. The serial data stream produced by the  $\Sigma\Delta$  converters is decimated and converted to parallel values by a sinc filter. Parallel data is then processed by an Infinite Impulse Response (IIR) low-pass filter.

A selection of low-pass filter characteristics are available. The cutoff frequency ( $f_C$ ) and rate at which acceleration samples are determined by the device ( $t_S$ ) vary depending upon which filter is chosen. Power consumption is also affected, as higher sample rates require greater DSP activity, which in turn requires more supply current.

Response parameters for available low-pass filter are summarized in [A.2](#).



## SECTION 3 SERIAL COMMUNICATIONS

Digital data communication is completed through synchronous serial transfers via the SPI port. Conventional SPI protocol is employed, acting as a slave device observing CPOL = 0, CPHA = 0, MSB first. All SPI transfers are 16-bits in length, and employ parity detection to ensure data integrity. During each SPI transfer, an odd number of bits received at D<sub>IN</sub> must be set to a logic '1' state, or a transient exception condition will be reported during the subsequent transfer. In all normal SPI responses, an odd number of bits transmitted on D<sub>OUT</sub> will be set to a logic '1' state. Besides parity detection and generation, several other data integrity features are incorporated into the transfer protocol.

### 3.1 EXCEPTION CONDITIONS

Under certain conditions, the MMA690xKQ will respond to serial commands with a word, which indicates that an exception condition has been detected. Response varies according to the Communication Protocol selected. Exceptions fall into five classes and are prioritized. If multiple exception conditions are detected, only the exception of highest priority is reported.

A reset exception condition exists following any device reset. Immediately following reset, a Device Initialization condition will be indicated until internal initialization of the circuitry has completed. Following internal initialization, a Device Reset exception condition exists until explicitly cleared by writing a logic '1' to the CE bit in DEVCTL.

Transient exception conditions result from data transmission errors such as data parity faults, an invalid number of clock cycles, etc. These exceptions are indicated during the following SPI transfer operation. These exceptions do not require an explicit operation to be cleared.

Behavioral exception conditions are defined as those which affect acceleration data results but do not indicate an error condition. In MMA690xKQ, the two behavioral exceptions are activation of self-test and a hold condition resulting from the external CAP/HOLD pin being driven to a logic high state. Register operations are unaffected by behavioral exceptions. Acceleration data transfers will complete, with the S/T1 and S/T0 bits indicating that one or both behavioral exception conditions exist.

See [Section 3.2](#) for behavioral exceptions reported by the Communications Protocol.

Critical error exceptions exist when an internal fault, which affects the reliability of device operation or acceleration results, is detected. If a critical error condition exists, an invalid data value is produced by the device in lieu of acceleration results. Register operations are unaffected except for the state of S[2:0]. Some critical errors, such as Temperature Fault, may be cleared by writing a logic '1' to the CE bit in DEVCTL, provided the underlying fault condition no longer persists. Other critical error conditions require reset of the device to clear.

#### 3.1.1 Defined Exceptions

##### 3.1.1.1 Internal Data Error

Class: Critical error

During reset, a number of internal registers are loaded from a fuse array which stores factory-programmed values. The resistance of each fuse is measured and compared to thresholds to ensure integrity of programmed data. Additionally, the register array is continuously monitored for correct parity at all time while the device is powered. If either the margin test or parity verification fail, an internal data error exception is reported.

Device reset is required to clear this exception condition.

##### 3.1.1.2 Internal Oscillator Fault

Class: Critical error

If an oscillator fault condition is detected, D<sub>OUT</sub> is driven high continuously when  $\overline{\text{CS}}$  is asserted, as illustrated in [Figure 3-1](#).

Device reset is required to clear this exception condition.

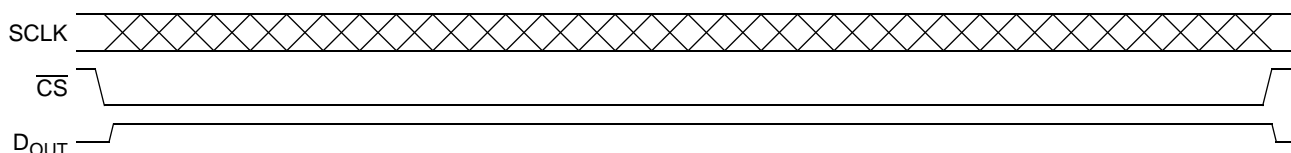

Figure 3-1 Oscillator Failure Response

### 3.1.1.3 Device Initialization

Class: Reset

Following a reset condition, the device requires a period of time to complete initialization of the DSP and internal registers. If multiple SPI transfers are attempted during this initialization period, the second and all subsequent transfers will result in this status. The first transfer following reset, regardless of the state of initialization returns device reset status.

This exception condition is cleared automatically upon completion of device initialization.

### 3.1.1.4 Temperature Fault

Class: Critical

The internal temperature sensor value exceeds the allowable limits for the device. This exception condition may be cleared by writing a logic '1' to the CE bit in DEVCTL, provided that the temperature has returned to within the operating limits of the device.

### 3.1.1.5 Unexpected Axis Selection

Class: Transient

An acceleration data request has been received with an axis specification which is not supported.

This exception condition is reported during the subsequent transfer.

### 3.1.1.6 Device Reset

Class: Reset

This exception condition is latched any time the device undergoes reset.

Device response will indicate the exception condition in lieu of acceleration data. The device reset exception condition must be explicitly cleared by writing a logic '1' to the CE bit in DEVCTL.

### 3.1.1.7 SPI Clock Fault

Class: Transient

A SPI clock fault may result from the following conditions:

- The number of rising clock edges detected while  $\overline{CS}$  is asserted is not equal to the expected number for the selected communications protocol
- SCLK is high when  $\overline{CS}$  is asserted

This exception condition is reported during the subsequent transfer.

### 3.1.1.8 D<sub>IN</sub> Parity Fault

Class: Transient

A parity error was detected on D<sub>IN</sub> during a data transmission.

This exception condition is reported during the subsequent transfer.

### 3.1.1.9 HOLD Condition

A HOLD condition exists when the  $\overline{CAP}/\text{HOLD}$  pin is driven to a logic high level. Self-test activation is controlled through configuration of ST1 and ST0 in DEVCTL.

### 3.1.1.10 Self-Test Activation

Class: Behavioral

The device provides two status bits in its response which will indicate a behavioral exception condition if a HOLD condition exists or self-test is activated. As these are not error conditions, device response is otherwise unaffected. Refer to [Section 3.2.1](#) for details regarding device response to behavioral exception conditions.

A HOLD condition exists when the  $\overline{CAP}/\text{HOLD}$  pin is driven to a logic level high level. Self-test activation is controlled through configuration of ST1 and ST0 in DEVCTL.

### 3.1.2 Exception Priority

Table 3-1 provides a summary of exception conditions and order of priority.

**Table 3-1. Exception Conditions**

Condition	Status Bit	Class
SPI Clock Fault, Previous Transfer	—	Transient
D <sub>IN</sub> Parity Fault, Previous Transfer	—	Transient
Internal Data Error	IDE	Critical Error
Internal Oscillator Fault	—	Critical Error
Device Initialization	DEVINIT	Reset
Device Reset	DEVRES	Reset
Temperature Fault	TF	Critical Error
Invalid Axis Selection	—	Transient
Hold Condition	—	Behavioral
Self-test	—	Behavioral

If an offset fault condition is detected simultaneously in both the X- and Y-axes, only the X-axis exception is reported by the device. Hold condition and self-test exceptions have equal priority; if both exceptions exist simultaneously, both are reported by the device.

## 3.2 COMMUNICATIONS PROTOCOL

The Communications Protocol provides 11-bit acceleration data along with enhanced status notification in the event that an exception condition is detected. All transfers are 16-bits in length, with the intended operation indicated by a two-bit transfer type code transmitted by the SPI master.

**Table 3-2. Transfer Type Codes**

T1	T0	Transfer Type
0	0	Register Operation
0	1	X-axis acceleration data
1	0	Y-axis acceleration data
1	1	Unused

Device response depends upon the transfer type code and the internal state of the device. If no exception condition has been detected, the device returns register or acceleration data as requested. If an exception condition exists, response depends upon the requested operation and the exception. Exceptions are divided into four classes: behavioral, reset, transient, and critical. Certain operations, such as register data write and register pointer write, will not be completed if an exception condition is detected during the associated SPI transfer. All exception conditions detected by MMA690xKQ are listed in Table 3-1. Response to exceptions is described below, and summarized in Table 3-3.

If both T1 and T0 are set to a logic '1' state, an invalid axis selection exception will be reported by the device.

### 3.2.1 Device Response

Device response depends upon exception conditions which may be present at the time the transfer takes place. In case of multiple exceptions, the exception class of highest priority will determine response.

**Table 3-3. Device Response, Exception Conditions**

Exception			Command		Response						Priority
Class	ST	HOLD	T1	T0	S2	S1	S0	Register	Acceleration Data		
Transient	X	X	X	X	1	1	1	Status code	Status code	Highest	
Reset	X	X	T1	T0	1	1	1	As requested	\$7FF	2	
Critical	X	X			1	1	1			2	
Behavioral	1	1			0	T1	T0			2	
	1	0			1	T1	T0			2	
	0	1			1	T1	T0			2	
None	0	0			0	T1	T0			Lowest	

ST = Self-test active

Commands and response under normal and exception conditions are summarized in the following tables. Note that only DEVCTL at address \$0E is writable when the device is in its normal operating mode.

**Table 3-4. Normal Response Summary**

Operation		Bit															
		15	14	13	12	11	10	9	8	7	6	5	4	3	2	1	0
Acceleration Data Read	Command	T1	T0	0	0	0	0	0	0	0	0	0	0	0	0	0	0
	Response	0	T1	T0	P	D10	D9	D8	D7	D6	D5	D4	D3	D2	D1	D0	0
Register Pointer Read	Command	0	0	0	0	0	1	0	0	0	0	0	0	0	0	0	0
	Response	0	0	0	0	0	P	0	0	A7	A6	A5	A4	A3	A2	A1	A0
Register Pointer Write	Command	0	0	0	1	0	P	0	0	A7	A6	A5	A4	A3	A2	A1	A0
	Response	0	0	0	0	1	0	0	0	0	0	0	0	0	0	0	0
Register Data Read	Command	0	0	1	0	0	0	0	0	0	0	0	0	0	0	0	0
	Response	0	0	0	1	0	P	0	0	D7	D6	D5	D4	D3	D2	D1	D0
Register Data Write	Command	0	0	1	1	0	P	0	0	D7	D6	D5	D4	D3	D2	D1	D0
	Response	0	0	0	1	1	P	0	0	A7	A6	A5	A4	A3	A2	A1	A0

P: Parity

T[1:0] Transfer type code

Note that only DEVCTL is writable when the device operates in normal operating mode. Attempts to write other registers do not constitute a fault condition, but have no effect.

**Table 3-5. Behavioral Response Summary, One Exception Condition**

Operation		Bit															
		15	14	13	12	11	10	9	8	7	6	5	4	3	2	1	0
Acceleration Data Read	Command	T1	T0	0	0	0	0	0	0	0	0	0	0	0	0	0	0
	Response	1	T1	T0	P	D10	D9	D8	D7	D6	D5	D4	D3	D2	D1	D0	0
Register Pointer Read	Command	0	0	0	0	0	1	0	0	0	0	0	0	0	0	0	0
	Response	1	1	1	0	0	P	0	1	A7	A6	A5	A4	A3	A2	A1	A0
Register Pointer Write	Command	0	0	0	1	0	P	0	0	A7	A6	A5	A4	A3	A2	A1	A0
	Response	1	1	1	0	1	0	0	1	0	0	0	0	0	0	0	0
Register Data Read	Command	0	0	1	0	0	0	0	0	0	0	0	0	0	0	0	0
	Response	1	1	1	1	0	P	0	1	D7	D6	D5	D4	D3	D2	D1	D0
Register Data Write	Command	0	0	1	1	0	P	0	0	D7	D6	D5	D4	D3	D2	D1	D0
	Response	1	1	1	1	1	P	0	1	A7	A6	A5	A4	A3	A2	A1	A0

P: Parity

T[1:0] Transfer type code

Behavioral exception conditions exist if self-test is active or the  $\overline{\text{CAP}}/\text{HOLD}$  input is in a logic high state. MMA690xKQ will respond as shown in Table 3-5 if either exception condition exists. If both exception conditions are true, response is as shown in Table 3-4.

**Table 3-6. Critical/Reset Exception Response Detail**

Operation		Bit															
		15	14	13	12	11	10	9	8	7	6	5	4	3	2	1	0
Acceleration Data Read	Command	T1	T0	0	0	0	0	0	0	0	0	0	0	0	0	0	0
	Response	1	1	1	1	1	1	1	1	1	1	1	1	1	1	1	0
Register Pointer Read	Command	0	0	0	0	0	1	0	0	0	0	0	0	0	0	0	0
	Response	1	1	1	0	0	P	1	0	Register Address							
Register Pointer Write	Command	0	0	0	1	0	P	0	0	Register Address							
	Response	1	1	1	0	1	0	1	0	0	0	0	0	0	0	0	0
Register Data Read	Command	0	0	1	0	0	0	0	0	0	0	0	0	0	0	0	0
	Response	1	1	1	1	0	P	1	0	Register Data							
Register Data Write	Command	0	0	1	1	0	P	0	0	Register Data							
	Response	1	1	1	1	1	P	1	0	Register Address							

P: Parity

T[1:0] Transfer type code

A special case exists if an internal oscillator fault is detected. This critical error condition results in  $D_{\text{OUT}}$  being driven high continuously while  $\overline{\text{CS}}$  is asserted, as detailed in Section 3.1.1.2.

**Table 3-7. Transient Exception Response Detail**

Operation		Bit															
		15	14	13	12	11	10	9	8	7	6	5	4	3	2	1	0
Acceleration Data Read	Command	T1	T0	0	0	0	0	0	0	0	0	0	0	0	0	0	0
	Response	1	1	1	P	Reserved value (refer to Table 3-8)											0
Register Pointer Read	Command	0	0	0	0	0	1	0	0	0	0	0	0	0	0	0	0
	Response	1	1	1	0	0	P	1	1	Status code							
Register Pointer Write	Command	0	0	0	1	0	P	0	0	Register Address							
	Response	1	1	1	0	1	P	1	1	Status code							
Register Data Read	Command	0	0	1	0	0	0	0	0	0	0	0	0	0	0	0	0
	Response	1	1	1	1	0	P	1	1	Status code							
Register Data Write	Command	0	0	1	1	0	P	0	0	Register Data							
	Response	1	1	1	1	1	P	1	1	Status code							

P: Parity

T[1:0] Transfer type code

### 3.2.2 Acceleration Data Transfer

The format of an acceleration data transfer is illustrated in Figure 3-2. Response to acceleration data transfers is summarized in Table 3-8. Note that a number of reserved values are defined to indicate error exceptions. MMA690xKQ will produce signed or unsigned data depending upon the state of the SD bit in the DSPCFG register, as described in Section 2.1.4.

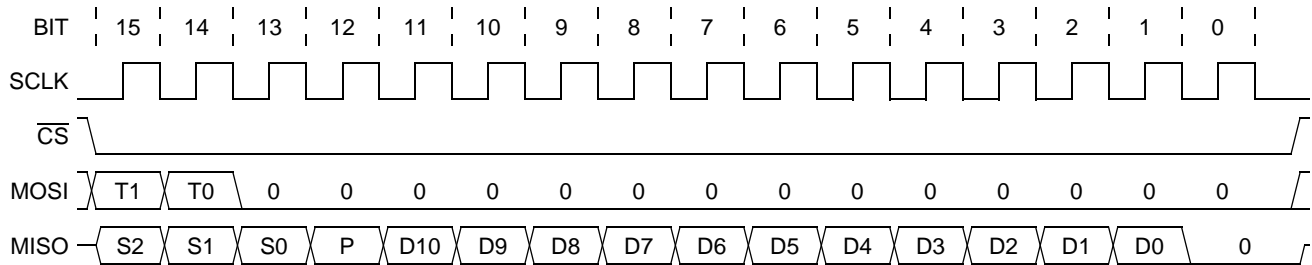

T[1:0]: Transfer type code  
S[2:0]: Status code

Figure 3-2 Communications Protocol, Acceleration Data Transfer

Table 3-8. Range of Output, Communications Protocol

11-bit Data Value		Definition
Unsigned		
Decimal	Hex	
2047	7FF	Critical/Reset Exception Value
2046	7FE	Invalid Axis Selection
2045	7FD	Internal Signal Path Overflow
2044	7FC	Overrange Value
2043	7FB	Maximum Positive Signal Level
	• • •	• • •
1024	400	Zero Signal Level
	• • •	• • •
5	005	Minimum Negative Signal Level
4	004	Underrange Value
3	003	Internal Signal Path Underflow
2	002	SPI Clock Fault
1	001	D <sub>IN</sub> Parity Fault
0	000	Reserved Value

### 3.2.3 Register Operations

Register operations involve four transfer types: register pointer write or read, and register data write or read. The basic format for register operations is illustrated in [Figure 3-3](#). Response from MMA690xKQ under normal conditions is illustrated. Specific details for each transfer type are provided in the command/response summaries provided in [Section 3.2.1](#).

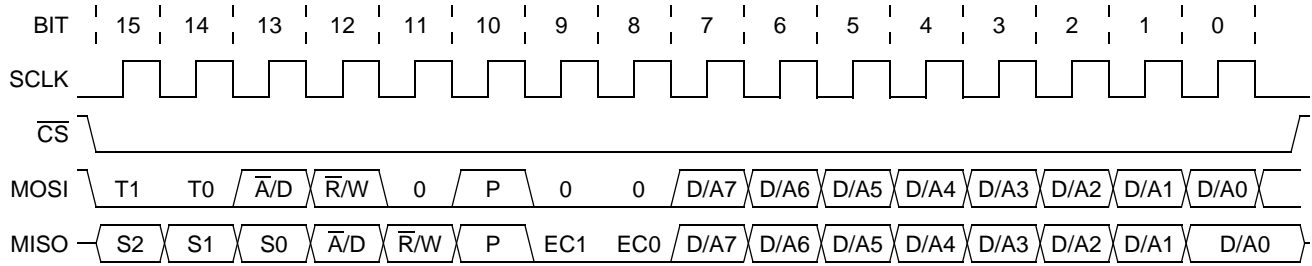

T[1:0]: Transfer type code

S[2:0]: Status code

A/D: ADDRESS/DATA

R/W: READ/WRITE

EC[1:0]: Exception class (refer to Table 3-9 below)

D/A[7:0]: Data or address, depending upon transfer type and status

**Figure 3-3 Communications Protocol, Register Operations**

**Table 3-9. Exception Class Encoding**

EC1	EC0	Exception Class
0	0	No Exception
0	1	Behavioral (one exception)
1	0	Critical/Reset
1	1	Transient

### 3.3 REPRESENTATION

**Table 3-10. Nominal 11-bit Acceleration Data Values**

11-bit Unsigned Digital Value	Nominal Acceleration	
	3.5g Range	5.0g Range
2047	Critical/Reset Exception Value	
2046	Invalid Axis Selection	
2045	Overflow	
2044	Overrange	
2043	+3.50g	+5.00g
2042	+3.50g	+5.00g
2041	+3.49g	+4.99g
•	•	•
•	•	•
•	•	•
1027	+10.3 mg	+14.7 mg
1026	+6.87 mg	+9.81 mg
1025	+3.43 mg	+4.91 mg
1024	0g	0g
1023	-3.43 mg	-4.91 mg
1022	-6.87 mg	-9.81 mg
1021	-10.3 mg	-14.7 mg
•	•	•
•	•	•
•	•	•
7	-3.49g	-4.99g
6	-3.50g	-5.00g
5	-3.50g	-5.00g
4	Underrange	
3	Underflow	
2	SPI Clock Fault	
1	D <sub>IN</sub> Parity Fault	
0	Reserved	

#### 3.3.1 Overrange Response

Positive acceleration levels which exceed the full-scale range of the device fall into two categories: overrange and overflow. Overrange conditions exist when the signal level is beyond the full-scale range of the device but within the computational limits of the DSP. An overflow condition occurs if the output of the low-pass filter equals or exceeds the maximum digital value which can be output from the sinc filter. Sinc filter saturation will occur before the internal data path width is exceeded. At 25 °C and OVLD = 0, the sinc filter will not saturate at sustained acceleration levels with the range of  $\pm 200g$ . The DSP operates predictably under all cases of overrange, although the signal may include residual high frequency components for some time after returning to the normal range of operation due to non-linear effects of the sensor. If an overflow condition occurs, the signal is internally clipped. The DSP will recover from an overflow condition within a few sample times after the input signal returns to the input range of the DSP. Due to internal clipping within the DSP, some high-frequency artifacts may be present in the output following an overflow condition.

For negative acceleration levels, corresponding underrange and underflow conditions are defined.

### 3.4 $\overline{\text{CAP/HOLD}}$ INPUT

The  $\overline{\text{CAP/HOLD}}$  input provides a system-level synchronization mechanism. When driven high, transfer of acceleration results from the DSP to the SPI buffers does not occur. The DSP continues its normal operation regardless of the state of  $\overline{\text{CAP/HOLD}}$ . Data read from the device when  $\overline{\text{CAP/HOLD}}$  is high will reflect the last values available from the DSP at the time of the signal transition.



## SECTION 4 OPERATING MODES

MMA690xKQ operates in one of two modes, factory test programming mode and normal operating mode. Factory test and programming mode is entered only when certain conditions are met, and provides support for programming of customer-defined data. Normal mode is entered by default when the device is powered on.

### 4.1 NORMAL OPERATING MODE

Normal mode is entered whenever the device is powered and the  $V_{PP}$  pin is held at or below the level of  $V_{CC}$ . In normal mode, acceleration data and device support data transfers are supported.

#### 4.1.1 Power-On Reset

Upon application of voltage at the  $V_{CC}$  pin, the internal regulators will begin driving the internal power supply rails. The  $C_{REG}$  and  $C_{REGA}$  pins are tied to the internal rails. As voltages at  $V_{CC}$ ,  $C_{REG}$  and  $C_{REGA}$  rise, the device becomes operational. An internal reset signal is asserted at this time. Separate comparators monitor all three voltages, and when all are above specified thresholds, the reset signal is negated and the device begins its initialization process.

#### 4.1.2 Device Initialization

Following any reset, the device completes a sequence of operations which initialize internal circuitry. Device initialization is completed in two phases. During the first phase, the fuse array is read and its contents are transferred to mirror registers. Power to the fuse array is then removed to reduce supply current load. A voltage reference used within the sensor interface stabilizes during the second phase. If the HPFSEL bit is set in the DSP configuration register (DSPCFG), the high-pass filter is also initialized during phase two.

The device will not respond to SPI accesses during initialization phase one. Acceleration results are not available during initialization phase two, however the SPI is functional and register operations may be performed. If an acceleration data access is attempted, the device will respond with non-acceleration data. The specific response depends upon the Communications Protocol selected.

The first initialization phase requires approximately 800  $\mu$ s to complete. The second phase completes in approximately 3.0 ms if no high-pass filter is selected, and 200 ms if the HPFSEL bit is programmed to a logic '1' state. The DEVINIT bit in the device status register (DEVSTAT) remains set following reset until the second phase of device initialization completes.

Following completion of the device initialization, the DEVRES bit in DEVSTAT may be cleared by writing a logic '1' value to CE in DEVCTL. This operation will clear the device reset exception. Once cleared, register operations may be completed or acceleration data values may be read from the device in any desired sequence.

## SECTION 5 PERFORMANCE SPECIFICATION

### 5.1 MAXIMUM RATINGS

Maximum ratings are the extreme limits to which the device can be exposed without permanently damaging it. The device contains circuitry to protect the inputs against damage from high static voltages; however, do not apply voltages higher than those shown in the table below. Keep input and output voltages within the range  $V_{SS} \leq V \leq V_{CC}$ .

Rating	Symbol	Value	Unit	
Supply Voltage	$V_{CC}$	-0.3 to +7	V	(1)
$C_{REG}$ , $C_{REGA}$ , $C_{REF}$	$V_{REG}$	-0.3 to +3	V	(1)
$V_{PP}$	$V_{REG}$	-0.3 to +11	V	(1)
SCLK, $\overline{CS}$ , $D_{IN}$ , $\overline{CAP}/HOLD$ , PCM_X, PCM_Y	$V_{IN}$	-0.3 to $V_{CC} + 0.3$	V	(1)
$D_{OUT}$ (high impedance state)	$V_{IN}$	-0.3 to $V_{CC} + 0.3$	V	(1)
Current Drain per Pin Excluding $V_{CC}$ and $V_{SS}$	I	10	mA	(1)
Powered Shock (six sides, 0.5 ms duration)	$g_{pms}$	$\pm 1500$	g	(1)
Unpowered Shock (six sides, 0.5 ms duration)	$g_{shock}$	$\pm 2000$	g	(1)
Drop Shock (to concrete surface)	$h_{DROP}$	1.2	m	(1)
Electrostatic Discharge				
Human Body Model (HBM)	$V_{ESD}$	$\pm 2000$	V	(1)
Charge Device Model (CDM)	$V_{ESD}$	$\pm 500$	V	(1)
Machine Model (MM)	$V_{ESD}$	$\pm 200$	V	(1)
Storage Temperature Range	$T_{stg}$	-40 to +125	$^{\circ}C$	(1)

1. Verified by characterization, not tested in production.

### 5.2 OPERATING RANGE

The operating ratings are the limits normally expected in the application and define the range of operation.

Characteristic	Symbol	Min	Typ	Max	Units	
Supply Voltage		$V_L$		$V_H$		(1)
Standard Operating Voltage, 3.3V operating range	$V_{CC}$	+3.15	+3.3	+3.45	V	(1)
Standard Operating Voltage, 5.0V operating range	$V_{CC}$	+4.75	+5.0	+5.25	V	
Operating Temperature Range	$T_A$	$T_L$	—	$T_H$	$^{\circ}C$	(2)
		-40		+105		

1. Characterized at all values of  $V_L$  and  $V_H$ . Production test is conducted at typical voltage unless otherwise noted.

2. Parameters tested 100% at final test.

### 5.3 ELECTRICAL CHARACTERISTICS

$V_L \leq (V_{CC} - V_{SS}) \leq V_H$ ,  $T_L \leq T_A \leq T_H$ ,  $|\Delta T_A| < 4.0$  k/min. unless otherwise specified

Characteristic	Symbol	Min	Typ	Max	Units	
Supply Current Drain $V_{CC} = 5.25$ V, $t_S = 64$ $\mu$ s	* $I_{DD}$	—	—	8.0	mA	(1)
Power-On Reset Threshold (See Figure 5-1)						
$V_{CC}$	$V_{POR\_N}$	2.77	—	3.15	V	(2)
$C_{REG}$	$V_{POR\_N}$	1.80	—	2.32	V	(2)
$C_{REGA}$	$V_{POR\_N}$	2.18	—	2.50	V	(2)
$C_{REF}$	$V_{POR\_N}$	1.11	—	1.29	V	(2)
Power-On Reset Threshold (See Figure 5-1)						
$V_{CC}$	$V_{POR\_A}$	2.77	—	2.95	V	(2)
$C_{REG}$	$V_{POR\_A}$	1.80	—	2.10	V	(2)
$C_{REGA}$	$V_{POR\_A}$	2.18	—	2.31	V	(2)
$C_{REF}$	$V_{POR\_A}$	1.11	—	1.19	V	(2)
Hysteresis ( $V_{POR\_N} - V_{POR\_A}$ , See Figure 5-1)						
$V_{CC}$	$V_{HYST}$	0	—	388	mV	(2)
$C_{REG}$	$V_{HYST}$	0	—	300	mV	(2)
$C_{REGA}$	$V_{HYST}$	0	—	261	mV	(2)
$C_{REF}$	$V_{HYST}$	0	—	150	mV	(2)
Internally Regulated Voltages						
$C_{REG}$	* $V_{DD}$	2.42	2.50	2.58	V	(1)
$C_{REGA}$ <sup>(3)</sup>	* $V_{2.5}$	2.42	2.50	2.58	V	(1)
$C_{REF}$	* $V_{REF}$	1.20	1.25	1.29	V	(1)
External Filter Capacitor ( $C_{REG}$ , $C_{REGA}$ )						
Value	$C_{REG}$	800	1000		nF	(2)
ESR (including interconnect resistance)	ESR	—	—	200	m $\Omega$	(2)
Power Supply Coupling		—	—	0.004	digit/mv	(2)
Nonlinearity	NL <sub>OUT</sub>	-1.0	—	1.0	% FSR	(2)
Noise (1.0 Hz-1.0 kHz)	$n_{SD}$	—	—	140	$\mu$ g/ $\sqrt{Hz}$	(2)
Sensitivity						
3.5g Range	* SENS	—	3.43	—	mg/digit	(1)
11-bit data						
5.0g Range	* SENS	—	4.91	—	mg/digit	(1)
11-bit data						
Sensitivity Error						
3.5g Range	* $\Delta$ SENS	-3.0	—	+3.0	%	(1)
5.0g Range		-3.5	—	+3.5	%	(1)
Offset at 0 g						
11-bit unsigned data	* $D_{OUT}$	—	1024	—	digit	(1)
Absolute offset error						
-40°C $\leq T_A \leq$ 105°C	* $\Delta D_{OUT}$	-20.4	—	+20.4	digit	(1)
Variation from measured absolute offset error						
-40°C $\leq T_A \leq$ 105°C	* $\Delta \Delta D_{OUT}$	-14.6	—	+14.6	digit	(1)

1. Parameters tested 100% at final test.

2. Verified by characterization, not tested in production.

3. Tested at  $V_{CC} = V_L$  and  $V_{CC} = V_H$ .

\* Indicates a Freescale critical characteristic.

**ELECTRICAL CHARACTERISTICS (continued)**
 $V_L \leq (V_{CC} - V_{SS}) \leq V_H$ ,  $T_L \leq T_A \leq T_H$ ,  $|\Delta T_A| < 4$  K/min unless otherwise specified.

Characteristic	Symbol	Min	Typ	Max	Units	
Range of Output						
11-bit data, unsigned						
Normal	RANGE	5	—	2043	digit	(1)
Critical Fault Value	CFU	—	2047	—	digit	(1)
Invalid Axis Selection	IAU	—	2046	—	digit	(1)
Positive Acceleration Overflow Code	OF <sub>U</sub>	—	2045	—	digit	(1)
Positive Acceleration Overrange Code	OR <sub>U</sub>	—	2044	—	digit	(1)
Negative Acceleration Underrange Code	UR <sub>U</sub>	—	4	—	digit	(1)
Negative Acceleration Underflow Code	UF <sub>U</sub>	—	3	—	digit	(1)
SPI Clock Fault	SCFU	—	2	—	digit	(1)
DIN Parity Fault	PFU	—	1	—	digit	(1)
Unused Code	UNUSED	—	0	—	digit	(1)
Output value on overrange						
11-bit data: 2043						
3.5g Range	g <sub>OVER</sub>	+3.22	+3.50	+3.79	g	(2)
5.0g Range	g <sub>OVER</sub>	+4.63	+5.00	+5.38	g	(2)
11-bit data: 5						
3.5g Range	g <sub>UNDER</sub>	-3.79	-3.50	-3.22	g	(2)
5.0g Range	g <sub>UNDER</sub>	-5.38	-5.00	-4.63	g	(2)
Maximum acceleration without saturation of internal circuitry (OVL = 0)	g <sub>SAT</sub>	< -12	—	> +12	g	(2)
Self-test Output Change <sup>(3)</sup>						
T <sub>A</sub> = 25 °C	* ΔST	472	525	578	mg	(4)
-40 ≤ T <sub>A</sub> ≤ 105 °C	* ΔST	437	525	630	mg	(4)
Cross-Axis Sensitivity <sup>(5)</sup>						
V <sub>ZX</sub>	V <sub>ZX</sub>	-3	—	+3	%	(2)
V <sub>YX</sub>	V <sub>YX</sub>	-3	—	+3	%	(2)
V <sub>ZY</sub>	V <sub>ZY</sub>	-3	—	+3	%	(2)
Output High Voltage						
D <sub>OUT</sub> (I <sub>Load</sub> = -100 μA)	V <sub>OH</sub>	0.85	—	—	V <sub>CC</sub>	(6)
Output Low Voltage						
D <sub>OUT</sub> , (I <sub>Load</sub> = 100 μA)	V <sub>OL</sub>	—	—	0.1	V <sub>CC</sub>	(6)
Output Loading (D <sub>OUT</sub> )						
Load Resistance	Z <sub>OUT</sub>	47	—	—	kΩ	(2)
Load Capacitance	C <sub>OUT</sub>	—	—	35	pF	(2)
Input High Voltage						
CS/RESET, SCLK, D <sub>IN</sub> , $\overline{\text{CAP}}/\text{HOLD}$	V <sub>IH</sub>	0.65	—	—	V <sub>CC</sub>	(6)
High Impedance Leakage Current						
D <sub>OUT</sub> , Input Voltage = V <sub>CC</sub> or V <sub>SS</sub>	I <sub>IL</sub>	-3	—	+3	μA	(4)
Input Low Voltage						
CS/RESET, SCLK, D <sub>IN</sub> , $\overline{\text{CAP}}/\text{HOLD}$	V <sub>IL</sub>	—	—	0.2	V <sub>CC</sub>	(6)
Input Current						
High (at V <sub>IH</sub> )						
SCLK, D <sub>IN</sub> , $\overline{\text{CAP}}/\text{HOLD}$	I <sub>IH</sub>	-30	-50	-260	μA	(6)
V <sub>PP</sub> (internal pull-down resistor)	R <sub>IN</sub>	190	270	350	kΩ	(6)
Low (at V <sub>IL</sub> )						
CS/RESET	I <sub>IL</sub>	30	50	260	μA	(6)

1. Functionality verified 100% via scan. timing characteristic is directly determined by internal oscillator frequency.

2. Verified by characterization, not tested in production.

3. Self-test deflection is trimmed in positive direction. Deflection in negative direction is approximately equal in magnitude.

4. Parameters tested 100% at final test.

5. Verified by characterization. Conformance guaranteed to 20 ppm.

6. Parameters tested 100% at unit probe.

\* Indicates a Freescale critical characteristic.

**MMA690xKQ**

## 5.4 CONTROL TIMING

$V_L \leq (V_{CC} - V_{SS}) \leq V_H$ ,  $T_L \leq T_A \leq T_H$ ,  $|\Delta T_A| < 4$  K/min unless otherwise specified

Characteristic	Symbol	Min	Typ	Max	Units	
DSP Low-Pass Filter Cut-Off Frequency	$f_{C(LPF)}$	47.5	50.0	52.5	Hz	(1)
Filter Order	$O_{LPF}$		2		1	(1)
Power-On Recovery Time	$t_{OP}$	—	—	840	$\mu s$	(1)
POR negated to $\overline{CS}$ low	$t_{XY}$	—	—	15	ms	(2)
Power applied to $X_{OUT}$ , $Y_{OUT}$ valid						
Internal Oscillator Frequency	$f_{OSC}$	3.8	4.0	4.2	MHz	(2)
Clock Monitor Threshold	$f_{MON}$	3.6	—	4.4	MHz	(1)
Chip Select to Internal Reset (See Figure 5-2)	$t_{CSRES}$	486	512	538	$\mu s$	(1)
Serial Interface Timing (See Figure 5-3)						
Clock period	$t_{SCLK}$	120	—	—	ns	(3)
CS asserted to SCLK high	$t_{CSCLK}$	60	—	—	ns	(3)
Data setup time	$t_{DC}$	20	—	—	ns	(3)
Data hold time	$t_{CDIN}$	10	—	—	ns	(3)
SCLK high to data out	$t_{CDOUT}$	—	—	50	ns	(3)
SCLK high to CS negated	$t_{CHCSH}$	60	—	—	ns	(3)
CS negated to CS asserted	$t_{CSN}$	600	—	—	ns	(3)
Sensing Element Natural Frequency	$f_n$	—	3	—	kHz	(3)
Sense Element Bandwidth (-3.0 dB)	$BW_{GCELL}$	—	1.2	—	kHz	(3)

1. Functionality verified 100% via scan. timing characteristic is directly determined by internal oscillator frequency.
2. Parameters tested 100% at final test.
3. Verified by characterization, not tested in production.

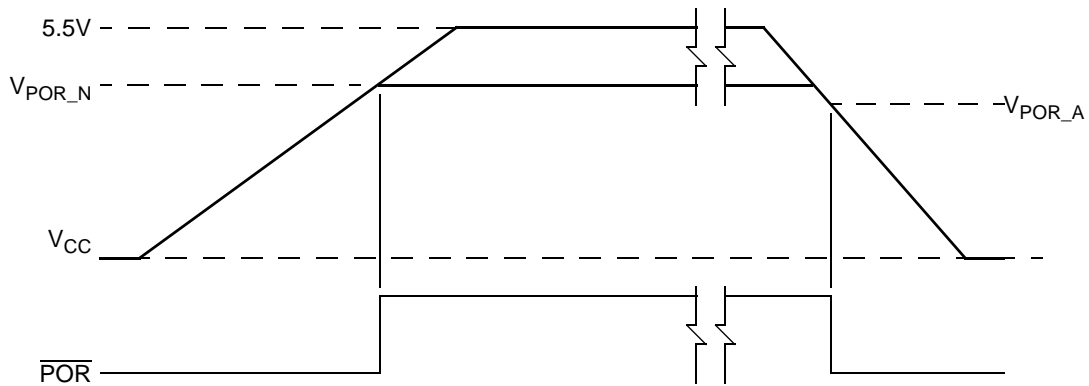

Figure 5-1 Power-Up Timing

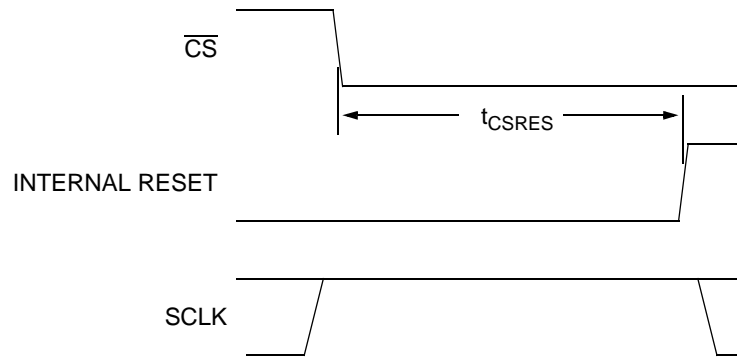

Figure 5-2  $\overline{CS}$  Reset Timing

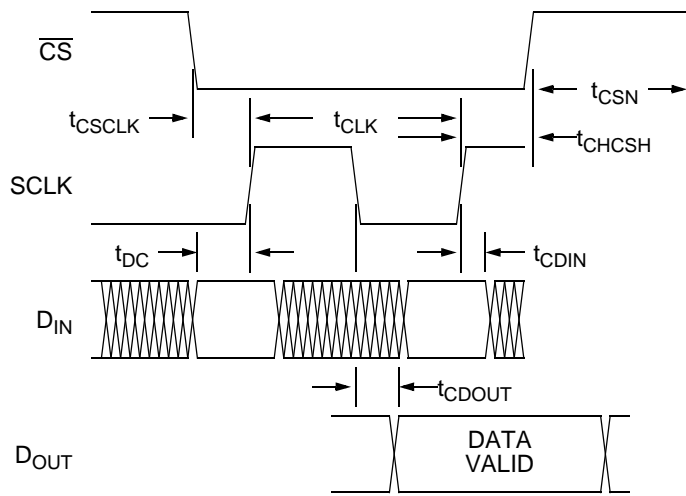
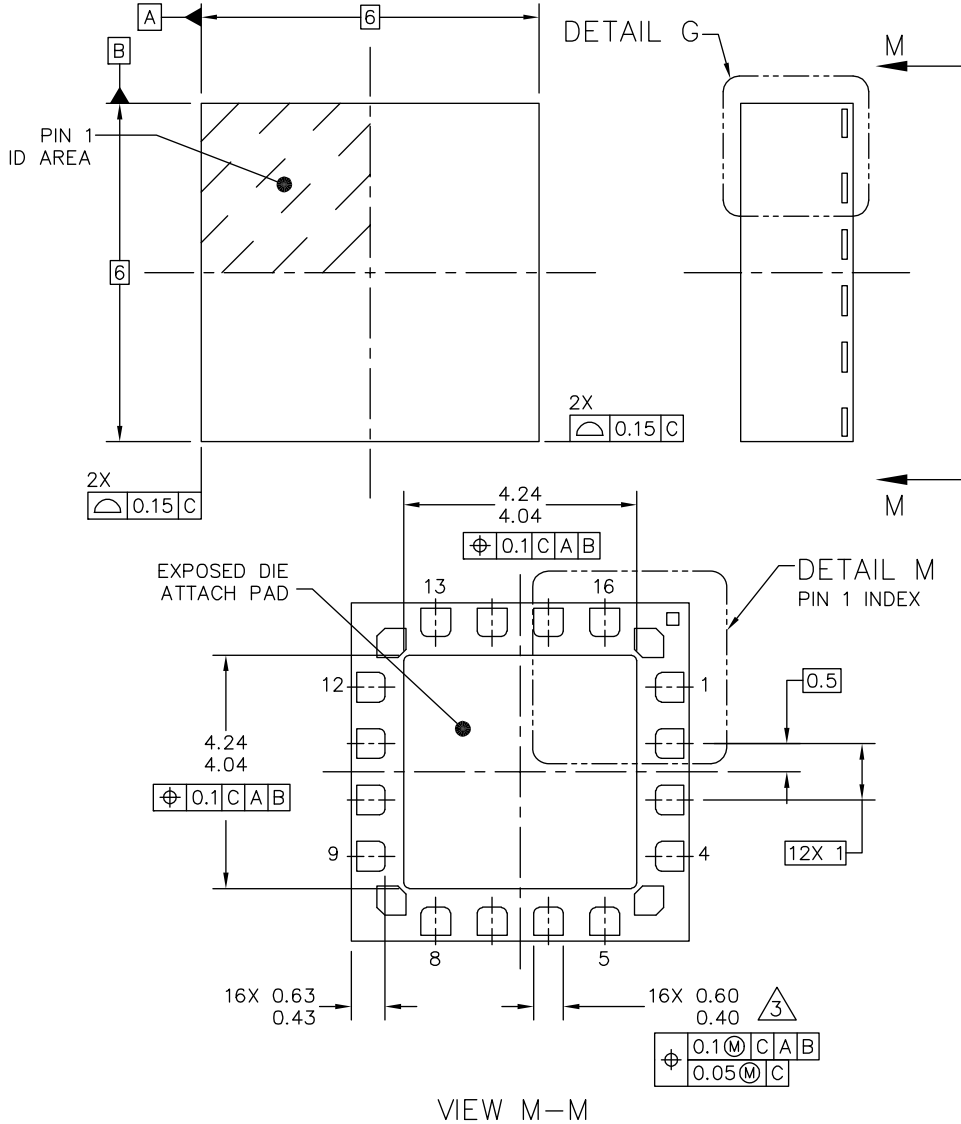

Figure 5-3 Serial Interface Timing

## 5.5 PACKAGE INFORMATION

The following documents provide a case outline drawing and information regarding printed wiring board mounting for the MMA690xKQ device. For the most current package revision, visit [www.freescale.com](http://www.freescale.com) and perform a keyword search using the "98A" listed below. The board mounting application note [AN3111](#) can be also located on the Freescale web site.

### 5.5.1 Package Dimensions



© FREESCALE SEMICONDUCTOR, INC. ALL RIGHTS RESERVED.	<b>MECHANICAL OUTLINE</b>	PRINT VERSION NOT TO SCALE	
TITLE: QUAD FLAT NON-LEADED PACKAGE (QFN) FOR SENSORS 16 TERMINAL, 1.0 PITCH (6 X 6 X 1.98)	DOCUMENT NO: 98ASA10571D	REV: B	
	CASE NUMBER: 1477-02	27 SEP 2006	
	STANDARD: NON-JEDEC		

98ASA10571D  
ISSUE B  
CASE 1477-02  
16 LEAD QFN

PAGE 1 OF 3

MMA690xKQ

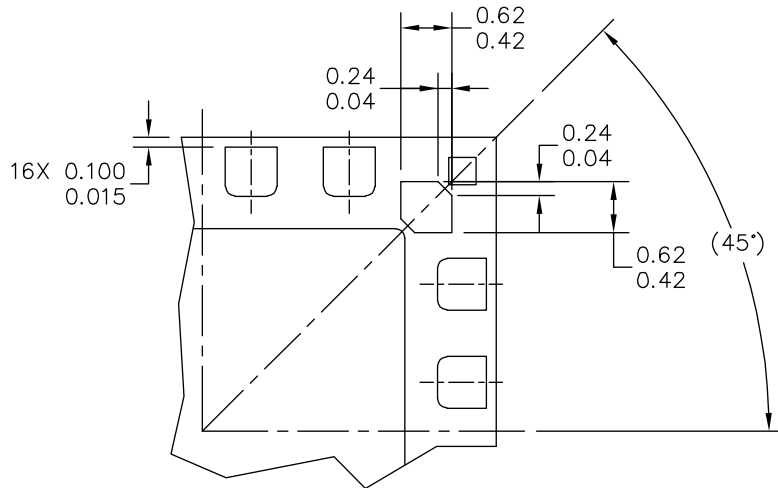

DETAIL M

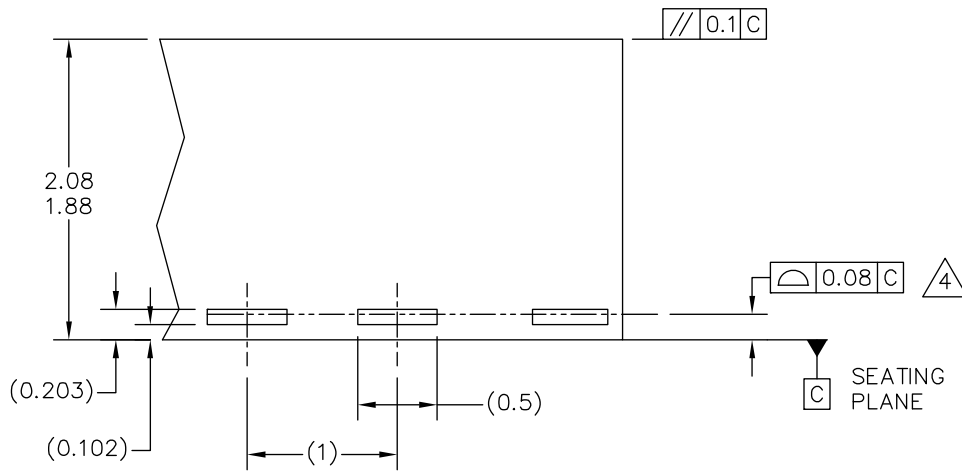

DETAIL G  
VIEW ROTATED 90° CW

© FREESCALE SEMICONDUCTOR, INC. ALL RIGHTS RESERVED.	<b>MECHANICAL OUTLINE</b>	PRINT VERSION NOT TO SCALE	
TITLE: QUAD FLAT NON-LEADED PACKAGE (QFN) FOR SENSORS 16 TERMINAL, 1.0 PITCH (6 X 6 X 1.98)	DOCUMENT NO: 98ASA10571D	REV: B	
	CASE NUMBER: 1477-02	27 SEP 2006	
	STANDARD: NON-JEDEC		

98ASA10571D  
ISSUE B  
CASE 1477-02  
16 LEAD QFN

PAGE 2 OF 3



NOTES:

1. ALL DIMENSIONS ARE IN MILLIMETERS.
2. INTERPRET DIMENSIONS AND TOLERANCES PER ASME Y14.5M-1994.
3. THIS DIMENSION APPLIES TO METALLIZED TERMINAL AND IS MEASURED BETWEEN 0.25MM AND 0.30MM FROM TERMINAL TIP.
4. COPLANARITY APPLIES TO THE EXPOSED HEAT SLUG, TERMINALS AND CORNER PADS.
5. RADIUS ON TERMINAL IS OPTIONAL.
6. MINIMUM METAL GAP SHOULD BE 0.2MM EXCEPT GAP BETWEEN CORNER PADS AND THE EXPOSED HEAT SLUG.

© FREESCALE SEMICONDUCTOR, INC. ALL RIGHTS RESERVED.	<b>MECHANICAL OUTLINE</b>	PRINT VERSION NOT TO SCALE	
TITLE: QUAD FLAT NON-LEADED PACKAGE (QFN) FOR SENSORS 16 TERMINAL, 1.0 PITCH (6 X 6 X 1.98)	DOCUMENT NO: 98ASA10571D	REV: B	
	CASE NUMBER: 1477-02	27 SEP 2006	
	STANDARD: NON-JEDEC		

98ASA10571D  
ISSUE B  
CASE 1477-02  
16 LEAD QFN

PAGE 3 OF 3

## APPENDIX A DIGITAL FILTER CHARACTERISTICS

Response curves for filter options are provided in this appendix.

### A.1 SINC FILTER CHARACTERISTICS

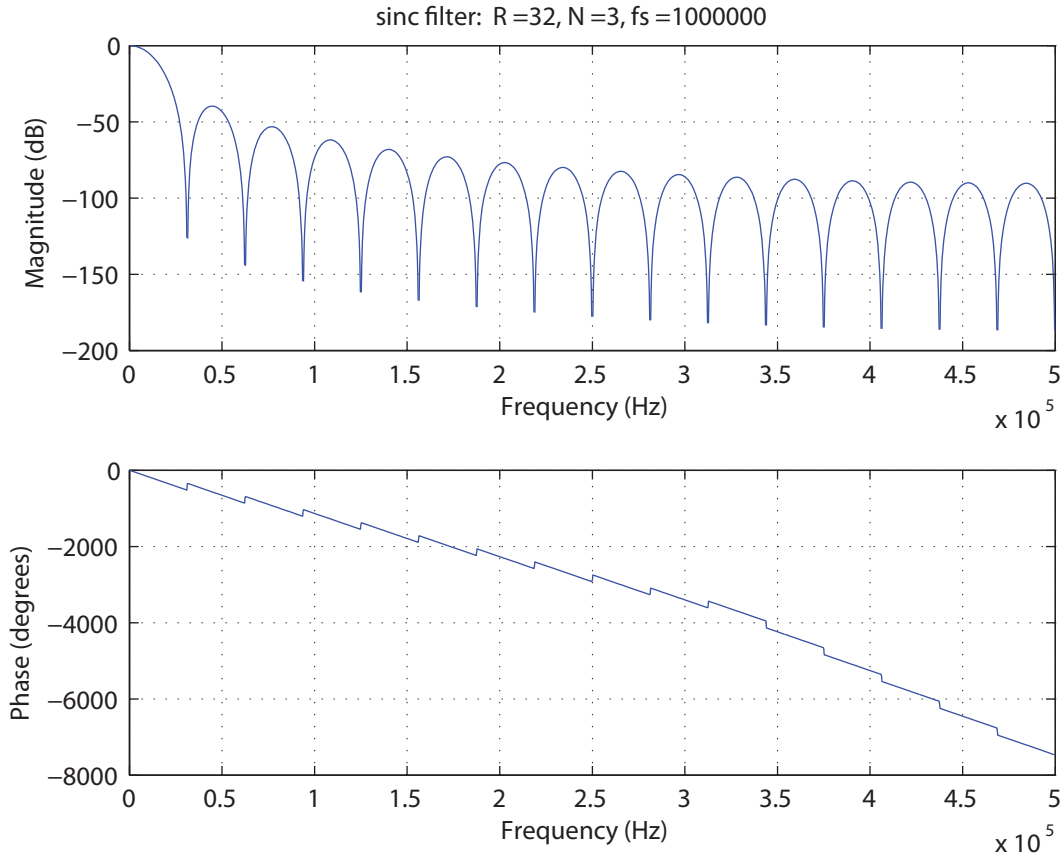

Figure A-1 Sinc Filter Response,  $t_s = 32 \mu s$

## A.2 LOW-PASS FILTER CHARACTERISTICS

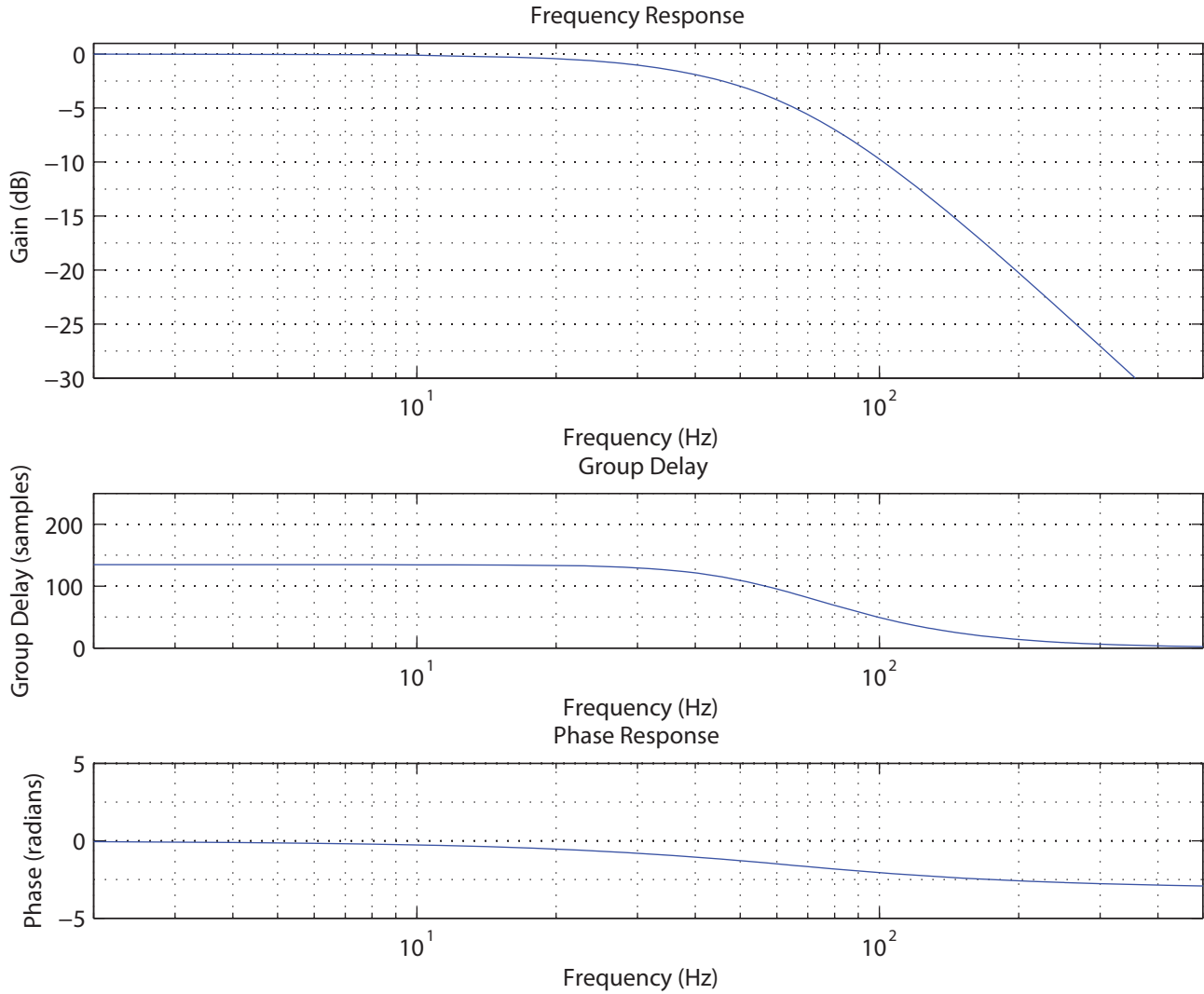

Figure A-2 Low-Pass Filter,  $f_c = 50$  Hz, Poles = 2,  $t_s = 32 \mu s$

**Table 6. Revision History**

Revision number	Revision date	Description of changes
4	03/2012	<ul style="list-style-type: none"> <li>Added SafeAssure logo, changed first paragraph and disclaimer to include trademark information.</li> </ul>
5	08/2012	<ul style="list-style-type: none"> <li>Changed device numbers to include "K" suffix.</li> <li>Changed AEC-Q100 qualified, Rev. G to Rev. F.</li> <li>Section 1.4.12, added</li> <li>Table 2-1: Corrected Addr \$0A and \$0B bits 7 and 6 from 0 and 1 to 1 and 0.</li> <li>Section 5.3 Electrical Characteristics table under Offset at 0 g: Changed Offset error to Absolute offset error, removed temperature range <math>T_A = 25^{\circ}\text{C}</math>, removed 11-bit data line, added temperature range <math>-40^{\circ}\text{C} \leq T_A \leq 105^{\circ}\text{C}</math> and values. Added Variation from measured absolute offset error with temperature range of <math>-40^{\circ}\text{C} \leq T_A \leq 105^{\circ}\text{C}</math> and values.</li> </ul>

**How to Reach Us:**

**Home Page:**

[freescale.com](http://freescale.com)

**Web Support:**

[freescale.com/support](http://freescale.com/support)

Information in this document is provided solely to enable system and software implementers to use Freescale products. There are no express or implied copyright licenses granted hereunder to design or fabricate any integrated circuits based on the information in this document.

Freescale reserves the right to make changes without further notice to any products herein. Freescale makes no warranty, representation, or guarantee regarding the suitability of its products for any particular purpose, nor does Freescale assume any liability arising out of the application or use of any product or circuit, and specifically disclaims any and all liability, including without limitation consequential or incidental damages. "Typical" parameters that may be provided in Freescale data sheets and/or specifications can and do vary in different applications, and actual performance may vary over time. All operating parameters, including "typicals," must be validated for each customer application by customer's technical experts. Freescale does not convey any license under its patent rights nor the rights of others. Freescale sells products pursuant to standard terms and conditions of sale, which can be found at the following address: [freescale.com/SalesTermsandConditions](http://freescale.com/SalesTermsandConditions).

Freescale, the Freescale logo, Altivec, C-5, CodeTest, CodeWarrior, ColdFire, C-Ware, Energy Efficient Solutions logo, Kinetis, mobileGT, PowerQUICC, Processor Expert, QorIQ, Qorivva, StarCore, Symphony, and VortiQa are trademarks of Freescale Semiconductor, Inc., Reg. U.S. Pat. & Tm. Off. Airfast, BeeKit, BeeStack, ColdFire+, CoreNet, Flexis, MagniV, MXC, Platform in a Package, QorIQ Qonverge, QUICC Engine, Ready Play, SafeAssure, SMARTMOS, TurboLink, Vybrid, and Xtrinsic are trademarks of Freescale Semiconductor, Inc. All other product or service names are the property of their respective owners.

© 2012 Freescale Semiconductor, Inc.

Document Number: MMA690xKQ

Rev. 5

08/2012

